

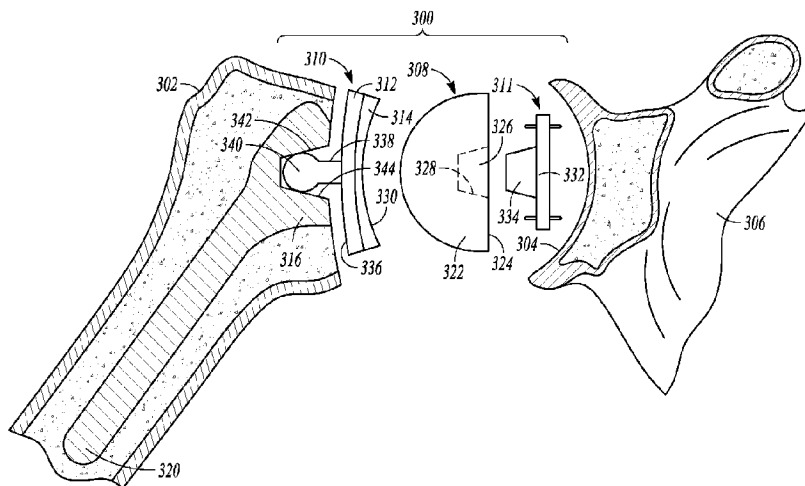

(86) Date de dépôt PCT/PCT Filing Date: 2018/01/05
 (87) Date publication PCT/PCT Publication Date: 2018/07/12
 (45) Date de délivrance/Issue Date: 2021/09/21
 (85) Entrée phase nationale/National Entry: 2019/07/05
 (86) N° demande PCT/PCT Application No.: US 2018/012537
 (87) N° publication PCT/PCT Publication No.: 2018/129286
 (30) Priorité/Priority: 2017/01/09 (US62/444,142)

(51) Cl.Int./Int.Cl. *A61F 2/40* (2006.01),
A61F 2/30 (2006.01)
 (72) Inventeurs/Inventors:
WINSLOW, NATHAN A., US;
HOPKINS, ANDREW ROLFE, CH
 (73) Propriétaire/Owner:
ZIMMER, INC., US
 (74) Agent: NORTON ROSE FULBRIGHT CANADA
LLP/S.E.N.C.R.L., S.R.L.

(54) Titre : RACCORDEMENTS ORTHOPEDIQUES REGLABLES
 (54) Title: ADJUSTABLE ORTHOPEDIC CONNECTIONS



(57) **Abrégé/Abstract:**

The disclosure includes methods and systems for making orthopedic connections where there is unique adjustability to the connection. Illustratively, one embodiment provides a connecting assembly for connecting a plurality of orthopedic components. Such connecting assemblies can include a first orthopedic component that provides a female bore (342). Additionally, the assembly can include a second orthopedic component that can be or include a male-type connecting member (340) that is positionable in the bore of the first orthopedic component. The male-type connecting member is in the form of a quasi-spherical member (340). The quasi-spherical member can include a textured outer surface, e.g., for contacting one or more walls or surfaces in the bore in a fashion that removably locks or helps to removably lock or fix the quasi-spherical member in the bore.

(12) INTERNATIONAL APPLICATION PUBLISHED UNDER THE PATENT COOPERATION TREATY (PCT)

(19) World Intellectual Property
Organization
International Bureau(43) International Publication Date
12 July 2018 (12.07.2018)(10) International Publication Number
WO 2018/129286 A1

- (51) **International Patent Classification:**
A61F 2/40 (2006.01) A61F 2/30 (2006.01)
- (21) **International Application Number:**
PCT/US2018/012537
- (22) **International Filing Date:**
05 January 2018 (05.01.2018)
- (25) **Filing Language:** English
- (26) **Publication Language:** English
- (30) **Priority Data:**
62/444,142 09 January 2017 (09.01.2017) US
- (71) **Applicant: ZIMMER, INC.** [US/US]; 1800 W. Center Street, Warsaw, Indiana 46580 (US).
- (72) **Inventors: WINSLOW, Nathan A.;** 2677 E Lake Tahoe Trail, Warsaw, Indiana 46582 (US). **HOPKINS, Andrew Rolfe;** Schlossackerstrasse 5, CH-8404 Winterthur (CH).
- (74) **Agent: ARORA, Suneel et al.;** Schwegman Lundberg & Woessner, P.A., P.O. Box 2938, Minneapolis, Minnesota 55402 (US).
- (81) **Designated States** (*unless otherwise indicated, for every kind of national protection available*): AE, AG, AL, AM, AO, AT, AU, AZ, BA, BB, BG, BH, BN, BR, BW, BY, BZ, CA, CH, CL, CN, CO, CR, CU, CZ, DE, DJ, DK, DM, DO, DZ, EC, EE, EG, ES, FI, GB, GD, GE, GH, GM, GT, HN, HR, HU, ID, IL, IN, IR, IS, JO, JP, KE, KG, KH, KN, KP, KR, KW, KZ, LA, LC, LK, LR, LS, LU, LY, MA, MD, ME, MG, MK, MN, MW, MX, MY, MZ, NA, NG, NI, NO, NZ, OM, PA, PE, PG, PH, PL, PT, QA, RO, RS, RU, RW, SA, SC, SD, SE, SG, SK, SL, SM, ST, SV, SY, TH, TJ, TM, TN, TR, TT, TZ, UA, UG, US, UZ, VC, VN, ZA, ZM, ZW.

(54) **Title:** ADJUSTABLE ORTHOPEDIC CONNECTIONS

FIG. 14

(57) **Abstract:** The disclosure includes methods and systems for making orthopedic connections where there is unique adjustability to the connection. Illustratively, one embodiment provides a connecting assembly for connecting a plurality of orthopedic components. Such connecting assemblies can include a first orthopedic component that provides a female bore (342). Additionally, the assembly can include a second orthopedic component that can be or include a male-type connecting member (340) that is positionable in the bore of the first orthopedic component. The male-type connecting member is in the form of a quasi-spherical member (344). The quasi-spherical member can include a textured outer surface, e.g., for contacting one or more walls or surfaces in the bore in a fashion that removably locks or helps to removably lock or fix the quasi-spherical member in the bore.

[Continued on next page]

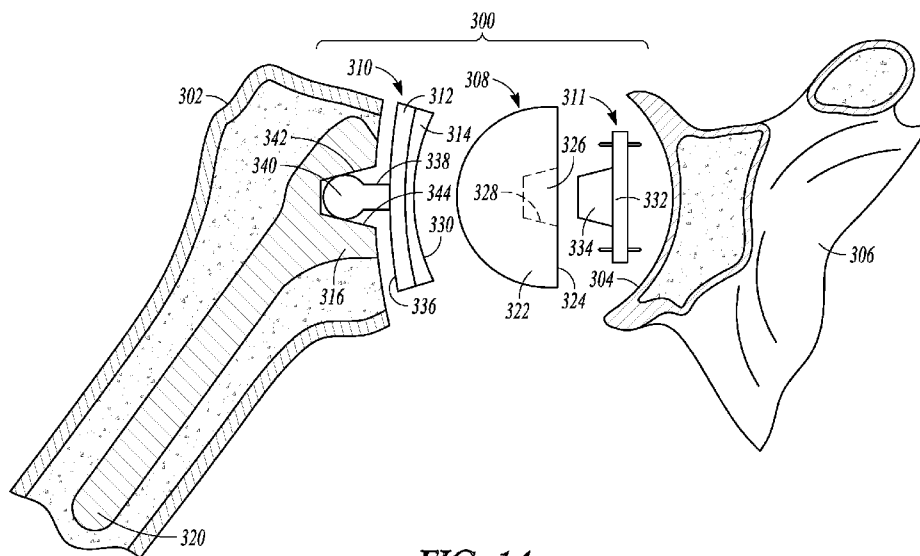

WO 2018/129286 A1

WO 2018/129286 A1 

(84) Designated States (*unless otherwise indicated, for every kind of regional protection available*): ARIPO (BW, GH, GM, KE, LR, LS, MW, MZ, NA, RW, SD, SL, ST, SZ, TZ, UG, ZM, ZW), Eurasian (AM, AZ, BY, KG, KZ, RU, TJ, TM), European (AL, AT, BE, BG, CH, CY, CZ, DE, DK, EE, ES, FI, FR, GB, GR, HR, HU, IE, IS, IT, LT, LU, LV, MC, MK, MT, NL, NO, PL, PT, RO, RS, SE, SI, SK, SM, TR), OAPI (BF, BJ, CF, CG, CI, CM, GA, GN, GQ, GW, KM, ML, MR, NE, SN, TD, TG).

Published:

— *with international search report (Art. 21(3))*

ADJUSTABLE ORTHOPEDIC CONNECTIONS

TECHNICAL FIELD

- [0001] The present disclosure relates generally to medical technology.
- 5 [0002] More particularly, the present disclosure relates in certain aspects to methods and systems for adjustably connecting orthopedic components, e.g., an articulating member to a stem or base.

BACKGROUND

- 10 [0003] As further background, the head or other portions of a proximal humerus can be replaced with prosthetic devices, e.g., to treat advanced degeneration of the proximal humerus. Due to the variability of the anatomy, e.g., head height, diameter, inclination and offset to the humeral canal, effective anatomical reconstruction can often necessitate a modular system offering a
- 15 variety of implant configurations.

OVERVIEW

- [0004] The present disclosure provides, in certain aspects, unique methods and systems for integrating or connecting orthopedic components.
- 20 Illustratively, one aspect of the present disclosure provides a connecting assembly for connecting a plurality of orthopedic components. This particular connecting assembly includes a first orthopedic component that provides a bore. The assembly also includes a second orthopedic component that can be or include a quasi-spherical member that is positionable in the bore of the first
- 25 orthopedic component for removably locking the quasi-spherical member to the first orthopedic component. The quasi-spherical member includes a textured outer surface such as any of those disclosed herein. The textured outer surface

can contact walls of the bore in a manner that removably locks or helps to removably lock the quasi-spherical member to the first orthopedic component. While not necessary, any suitable combination of the following features can be incorporated into or associated with the connecting assembly. The quasi-spherical member can be part of a bone screw or fastener. Such a bone screw can include a shaft (e.g., a fully or partially threaded shaft with or without one or more tapered and/or one or more non-tapered longitudinal sections) that extends away from the quasi-spherical member, for example, where the quasi-spherical member forms all or part of a head of the screw. The orthopedic component can be an implant. The orthopedic component can be a bone plate. With a bone plate, the bore can extend partially or entirely through a wall of the plate. In some forms, a bore will extend entirely through a wall of the plate and a leading tip of the screw will be passed through the bore in advance of the quasi-spherical member. The first orthopedic component can be an articulating ball or head member such as a humeral head. The quasi-spherical member can be a modular component that is connectable to a separate humeral stem component. The textured outer surface can cover a significant portion of the quasi-spherical member such as more than 25% or more than 50%. The textured outer surface can include a plurality of planar surface elements, e.g., with polygonal perimeters.

[0005] In one aspect, the present disclosure provides a ball-side prosthesis for articulating with a socket in a ball and socket joint in a patient. This particular prosthesis comprises an articulating ball member that includes a top side and a bottom side. The top side provides a convex articulating surface for articulating with surfaces in the socket. The bottom side includes an opening into a bore that extends into the articulating ball member from the bottom side toward the top side. The prosthesis further comprises a fixation member that is anchorable to a bone of the patient remaining on the ball side of the ball and socket joint. The prosthesis further comprises a quasi-spherical member that is disposed at a proximal end of the fixation member. The quasi-spherical member is positionable in the bore of the articulating ball member for removably locking the quasi-spherical member to the articulating ball member. The quasi-spherical member includes a textured outer surface such as any of those disclosed herein

for contacting walls of the bore. While not necessary, any suitable combination of the following features can be incorporated into or associated with the prosthesis. The fixation member can include an elongate stem that is receivable in an intramedullary canal on the ball side of the ball and socket joint. The articulating ball member can be a humeral head. The bore can include a tapered segment. The fixation member and the quasi-spherical member can be modular components that are connectable to one another, e.g., using a Morse-type taper connection. The textured outer surface can cover any suitable percentage of the quasi-spherical member, e.g., between about 10% and 100%, or between about 40% and about 99%, or between about 50% and about 90%. The textured outer surface can include a plurality of generally planar faces, e.g., including generally planar faces spaced from one another on the quasi-spherical member and/or including generally planar faces contiguous with one another on the quasi-spherical member. The textured outer surface can include a plurality of surface elements with polygonal perimeters, e.g., including surface elements with planar surfaces within the polygonal perimeters and/or including surface elements with convex and/or concave surfaces within the polygonal perimeters. The textured outer surface can include a three-dimensional tessellation incorporating polygonal surfaces. The quasi-spherical member can approximate a honeycomb of polyhedral cells.

[0006] In one aspect, the present disclosure provides a quasi-spherical member that is positionable in the bore of an orthopedic component for removably locking the quasi-spherical member to the orthopedic component. The quasi-spherical member comprises a textured outer surface that includes a plurality of outermost extensions that are spaced from one another on the textured outer surface and which define a first radius of the quasi-spherical member and a plurality of innermost depressions that are spaced from one another on the textured outer surface and which define a second radius of the quasi-spherical member. The textured outer surface can contact walls of the bore in a manner that removably locks or helps to removably lock the quasi-spherical member to the orthopedic component. While not necessary, any suitable combination of the following features can be incorporated into or associated with the quasi-spherical member or orthopedic component. The bore can include

a tapered segment with a first diameter that is twice the first radius and a second diameter that is twice the second radius. The plurality of innermost depressions can occur on planar and/or non-planar (e.g., concave) surfaces on the quasi-spherical member. The plurality of outermost extensions can be symmetrical
5 peaks on the quasi-spherical member.

[0007] In one aspect, the present disclosure provides a humeral prosthesis for articulating with a glenoid cavity in a patient. This particular humeral prosthesis comprises a humeral head member that includes a top side and a bottom side. The top side provides a convex articulating surface for
10 articulating with surfaces in the glenoid cavity, e.g., a native glenoid cavity. The bottom side includes an opening into a bore that extends into the humeral head member from the bottom side toward the top side. The prosthesis further includes a fixation member that is anchorable to a humerus of the patient. The prosthesis further includes a quasi-spherical member that is disposed at a
15 proximal end of the fixation member, e.g., where the quasi-spherical member is an integral part of the fixation member. The quasi-spherical member is positionable in the bore of the humeral head member for removably locking the quasi-spherical member to the humeral head member. The quasi-spherical member includes a textured outer surface such as any of those disclosed herein
20 for contacting walls of the bore. In one embodiment, the textured outer surface includes a plurality of outermost extensions that are spaced from one another on the textured outer surface and which define a first radius of the quasi-spherical member and a plurality of innermost depressions that are spaced from one another on the textured outer surface and which define a second radius of the
25 quasi-spherical member. While not necessary, the fixation member can include an elongate stem that is receivable in an intramedullary canal on the ball side of the ball and socket joint and/or the textured outer surface can include a three-dimensional tessellation of triangular surfaces whose vertices provide the plurality of outermost extensions.

30 [0008] In some aspects, the present disclosure provides systems and methods that can be used in a humeral reconstruction surgery in which the head or proximal end of the humerus bone is replaced or repaired, e.g., providing surgeons with modular humeral head systems offering rapid and accurate

adjustability. In some forms, modular humeral heads will have eccentric centers and/or be used with stemmed or stemless humeral fixation members.

5 [0009] Some aspects of the present disclosure involve connections between a female-type bore in a first orthopedic member such as an orthopedic plate (e.g., a bone plate) and a quasi-spherical member or another male-type connector of a second orthopedic member. This second member can be any orthopedic element or device to be connected to the plate. In certain
10 embodiments, this second member will be something to be driven into or otherwise received in bone, for example, to attach the plate to a bone. This second member can be a screw, fastener, pin, spike, or nail. For example, the second member can be a screw with a tapered shaft, or having a significant longitudinal section of the shaft being tapered with or without threading. In some
15 embodiments, the first orthopedic member will be a non-plate orthopedic device. In some embodiments, the first orthopedic member will be an orthopedic implant (e.g., a knee, hip, shoulder, ankle, or another joint implant).

[0010] Some aspects of the present disclosure involve devices/systems/methods relating to a reverse shoulder arthroplasty. A traditional shoulder joint implantation may require that the rotator cuff muscles be present and function normally. When this is not the case, a reverse shoulder
20 prosthesis may be preferable. In the reverse shoulder prosthesis, a humeral implant prosthesis can include a fixation member, a humeral tray connected to the fixation member, and an articulating liner retained in the humeral tray. A glenoid component can support a head member which can articulate with the articulating liner when the humerus bone moves.

25 [0011] The humeral tray can include a top surface for receiving the articulating liner. The humeral tray can include a bottom surface that can include a tray stem having a quasi-spherical member located adjacent the end of the tray stem. The quasi-spherical member can include a textured surface as described above. The quasi-spherical member can be located in a bore at the proximal end
30 of the fixation member. A surgeon can modify an orientation of the humeral tray by the variable positioning of the quasi-spherical member in the bore. Once the desired orientation is located, the quasi-spherical member can be locked into

place. This can allow the surgeon to provide a more accurate fit of the humeral prosthesis to an individual's anatomy.

5 [0012] Various types of implant components have been used in devices/systems/methods relating to shoulder implant assemblies, including reverse and traditional shoulder arthroplasty. Examples of these devices/systems/methods are illustrated and described in U.S. Pat. Nos. 6,942,699; 7,175,663; 7,241,314; 7,753,959; 7,918,895; 8,246,687; and 8,317,871.

10 [0013] Each of these non-limiting examples can stand on its own or can be combined in various permutations or combinations with one or more of the other examples.

BRIEF DESCRIPTION OF THE DRAWINGS

15 [0014] Corresponding reference characters indicate corresponding parts throughout the several views. The exemplifications set out herein illustrate exemplary embodiments of the invention, and such exemplifications are not to be construed as limiting the scope of the invention in any manner. In the drawings, which are not necessarily drawn to scale, like numerals may describe similar components in different views. Like numerals having different letter 20 suffixes may represent different instances of similar components. The drawings illustrate generally, by way of example, but not by way of limitation, various embodiments discussed in the present document.

[0015] FIG. 1A shows a humeral prosthesis according to one embodiment of the present disclosure.

25 [0016] FIG. 1B shows an alternative orientation of the humeral prosthesis of FIG. 1A.

[0017] FIG. 1C shows a radiographic image of an illustrative humeral prosthesis.

30 [0018] FIG. 2 shows a humeral head member according to one embodiment of the present disclosure.

[0019] FIG. 3A shows a side, cross-sectional view of a humeral head member according to one embodiment of the present disclosure.

- [0020] FIG. 3B illustrates a radius of a perfect sphere.
- [0021] FIG. 3C shows a quasi-spherical member with a textured outer surface according to one embodiment of the present disclosure.
- [0022] FIGS. 4A-4D show quasi-spherical members with textured outer surfaces of different densities according to additional embodiments of the present disclosure.
- [0023] FIG. 5A shows a quasi-spherical member with a textured outer surface according to one embodiment of the present disclosure.
- [0024] FIG. 5B shows a quasi-ellipsoid member with a textured outer surface according to one embodiment of the present disclosure.
- [0025] FIG. 6A shows a quasi-spherical member with a textured outer surface according to one embodiment of the present disclosure.
- [0026] FIG. 6B shows a quasi-spherical member with a textured outer surface according to one embodiment of the present disclosure.
- [0027] FIG. 7A shows a humeral member according to one embodiment of the present disclosure.
- [0028] FIG. 7B shows a humeral member according to another embodiment of the present disclosure.
- [0029] FIG. 8 shows a humeral member according to one embodiment of the present disclosure.
- [0030] FIG. 9 shows a humeral member according to another embodiment of the present disclosure.
- [0031] FIG. 10 shows a front view of a bone screw according to one embodiment of the present disclosure.
- [0032] FIG. 11 shows a front view of an orthopedic assembly according to one embodiment of the present disclosure.
- [0033] FIG. 12 shows a front view of an orthopedic assembly according to another embodiment of the present disclosure.
- [0034] FIG. 13A shows a top view of an orthopedic plate according to one embodiment of the present disclosure.
- [0035] FIG. 13B is a cross-sectional view taken along view line 13B-13B from FIG. 13A.

- [0036] FIG. 13C shows part of an orthopedic plate according to another embodiment of the present disclosure.
- [0037] FIG. 14 shows an implant assembly for a total shoulder joint replacement, according to at least one embodiment of the present disclosure.
- 5 [0038] FIG. 15 shows a perspective view of a humeral tray assembly, according to at least one embodiment of the present disclosure.
- [0039] FIG. 16 shows a cross-section of a humeral tray assembly, according to at least one embodiment of the present disclosure.
- [0040] FIG. 17 shows a cross-section of a tray engaged with a fixture
10 member, according to at least one embodiment of the present disclosure.
- [0041] FIG. 18 shows a cross-section of a tray engaged with a fixture member, according to at least one embodiment of the present disclosure.
- [0042] FIG. 19 shows a cross-section of a tray engaged with a fixture member, according to at least one embodiment of the present disclosure.
- 15 [0043] FIG. 20 shows a cross-section of a tray engaged with a fixture member, according to at least one embodiment of the present disclosure.
- [0044] FIG. 21 shows a humeral tray assembly having an internal bore, according to at least one embodiment of the present disclosure.
- [0045] FIG. 22 illustrates an implant assembly for a total shoulder joint
20 replacement, according to at least one embodiment of the present disclosure.
- [0046] FIG. 23 illustrates an implant assembly for a total shoulder joint replacement having a secondary locking system, according to at least one embodiment of the present disclosure.
- [0047] FIG. 24 illustrates an implant assembly for a total shoulder joint
25 replacement having a secondary locking system, according to at least one embodiment of the present disclosure.
- [0048] FIG. 25 illustrates an implant assembly for a total shoulder joint replacement having a secondary locking system, according to at least one embodiment of the present disclosure.
- 30 [0049] FIG. 26 illustrates an implant assembly for a total shoulder joint replacement having a secondary locking system, according to at least one embodiment of the present disclosure.

DETAILED DESCRIPTION

[0050] As disclosed above, the present disclosure provides, in certain aspects, unique methods and systems for making orthopedic connections. Illustratively, some embodiments of the present disclosure provide a connecting assembly for connecting a plurality of orthopedic components, e.g., where the connecting assembly itself provides a unique way to spatially adjust a first component relative to a second component. Such connecting assemblies can include a first orthopedic component that provides a female bore. Additionally, the assembly can include a second orthopedic component that can be or include a male-type connecting member that is positionable in the bore of the first orthopedic component. In one preferred form, the male-type connecting member will include a quasi-spherical member. The quasi-spherical member includes a textured outer surface, e.g., for contacting one or more walls or surfaces in the bore in a fashion that removably locks or helps to removably lock or fix the quasi-spherical member in the bore. Other suitable male-type connecting members incorporating textured outer surfaces in accordance with the present disclosure can approximate other shapes (e.g., non-spherical shapes such as a quasi-ellipsoid shape) as discussed elsewhere herein. In some preferred embodiments, the geometry of the textured outer surface will allow the quasi-spherical member to be positioned and locked in the bore in a rather large number of orientations or angular positions, for example, to account for variability in the patient's anatomy. In some instances, such a connecting assembly will be part of a ball-side prosthesis for articulating with a socket in a ball and socket joint in a patient. For example, the first orthopedic component can be an articulating ball member such as a humeral head member that includes a top side and a bottom side. The top side can provide a convex articulating surface for articulating with surfaces in the socket. The bottom side can include an opening into the bore, e.g., extending into the articulating ball member from the bottom side toward the top side. The quasi-spherical member can be disposed at the proximal end of a fixation member that is anchorable to a bone of the patient remaining on the ball side of the ball and socket joint. In the context of a humeral prosthesis, for example, the orientation or angular position of the quasi-spherical member in the bore can be adjusted to account for variability in

things like head height, diameter, inclination and offset to the humeral canal. In some embodiments, the first orthopedic component is a bone plate, and the second orthopedic component is a bone screw such as where a leading tip of a shaft of the screw is passed through the plate through the female bore and into bone in advance of a quasi-spherical member that forms part of the screw, e.g., forming all or part of a head of the screw. Thereafter, the quasi-spherical member can be received and locked in the bore in a rather large number of orientations or angular positions for attaching the plate to bone, for example, by advancing the screw to a desired final location in the bone. Such connections can be effective to resist back-out of the screw. In some instances, a shaft or a leading tip of a shaft never passes through a female bore in a plate. In some embodiments, a leading tip of the shaft enters bone before the screw contacts or is associated with the plate. In some forms, a screw is advanced to a desired final location in the bone before the quasi-spherical member is locked in the female bore, for example, where a plate is impacted down onto a pre-positioned screw so that the quasi-spherical member is forcefully received and locked in the female bore.

[0051] In some embodiments, the first component can be a fixation member that can be inserted into a humerus bone of a patient. The fixation member can define a bore near its proximal end. In some embodiments, the second component can be a humeral tray member. The humeral tray member can include a tray stem extending from the back surface of the tray. The distal end of the stem can include a quasi-spherical member. A surgeon can adjust the position of the tray relative to the fixation member and lock the quasi-spherical member into the bore when the desired orientation is achieved.

[0052] FIGS. 1A-1B show an illustrative humeral prosthesis 10. This particular humeral prosthesis 10 can include a humeral head member 40 and an assembly 9. The assembly 9 can include a quasi-spherical member 20, and a humeral fixation member 60. The humeral head member 40 includes a top side 41 and a bottom side 42. The humeral head member 40 can be hemispherical or partially-spherical in shape and, in this particular instance, the top side 41 provides a convex articulating surface 47 for articulating with glenoid surfaces, e.g., natural or synthetic mating glenoid surfaces of a human or animal shoulder.

The humeral head member 40 can be formed with any suitable material including metals, ceramics, polymers or combinations of these materials. The humeral fixation member 60 is anchorable to a humerus. The humeral fixation member 60 includes a stem 70 which is sized and shaped to be inserted into a canal 73 of the humerus 74 (See FIG. 1C). The stem 70 can be anchored in any suitable manner such as being cemented, non-cemented, pinned, or screwed to the surrounding bone material and can be configured to promote bone ingrowth. The stem 70 can be formed with any suitable material including metals, ceramics, polymers or combinations of these materials. FIG. 1C is a radiographic image of a humeral prosthesis implanted after an illustrative shoulder replacement surgery. The stem 70 of the fixation member 60 can be installed in the canal 73 of a humerus bone 74. The humeral head member (head) 40 can be located at the proximal end 59 of the humerus 74 and can articulate with natural or synthetic mating glenoid surfaces 58 of the shoulder 75.

15 [0053] Referring to FIGS. 1A-1B, during a shoulder replacement in which a humeral prosthesis 10 is required and perhaps owing to variations in anatomy, a surgeon may elect to adjust the orientation or angular position of a humeral head 40 (shown in cross-section) relative to a remaining anatomical structure or another implant component such as humeral fixation member 60.

20 The humeral head member 40 includes a bottom side 42 that provides a bore 43 with one or more walls 44. The bore extends into the humeral head member from the bottom side toward the top side. The bore 43 can be tapered with the opening wider at the bottom side 42 and narrowing towards a base 48 forming a bottom of the bore 43. A suitable female bore can be tapered or non-tapered. A suitable female-type bore can be or incorporate any suitable three-dimensional shape, e.g., incorporating rectilinear and/or curvilinear features. A suitable female-type bore can have a frustoconical shape. Suitable shapes of a female-type bore can be or include full and partial forms of wedges, tapered bodies, toroids, conoids, catenoids, cubes, parallelepipeds, prisms, and combinations of the same. Suitable shapes include but are not limited to full or partial cylinders, cuboids, cones, pyramids, and tetrahedrons, and combinations of the same, and in this regard, it will be understood that male-type connectors incorporating textured outer surfaces in accordance with certain aspects of the present

disclosure can approximate any suitable shape as well. Thus, in addition to spheres, such male-type connecting members can approximate non-spherical shapes, e.g., incorporating any suitable three-dimensional rectilinear and/or curvilinear shape. Illustratively, in some preferred forms, a male-type connector
5 incorporating a textured outer surface in accordance with the present disclosure will approximate all or part of a shape like a sphere (e.g., a partial sphere such as a hemisphere), ellipsoid, oblate spheroid, prolate spheroid, catenoid, conoid, or paraboloid of revolution.

[0054] Continuing with FIGS. 1A-B, contact between the quasi-spherical member 20 and walls 44 of the bore at one or more interfaces 22 can allow a surgeon to orient the humeral head 40 in a wide range of positions, two of which can be seen in the different angles of the humeral head 40 illustrated in FIGS. 1A and 1B. FIG. 1A shows the relationship between the fixation member 60 and the humeral head 40 at a first angle 17 and FIG. 1B shows the relationship between
15 the fixation member 60 and the humeral head 40 at a second angle 18. The geometry of the quasi-spherical member 20 can allow these angular adjustments to be made in three dimensions. During an evaluation of the orientation or angular position of the humeral head 40, the quasi-spherical member 20 may be only partially inserted into the bore 43. Even then, there may be sufficient grip to
20 hold the components together to allow the surgeon to judge the suitability of the positioning. Once the humeral head 40 is deemed by a surgeon to be suitably oriented, the quasi-spherical member 20 can then be more fully inserted into the bore 43, e.g., by impaction loading accomplished by pressure, impact force or otherwise. In some instances, forcible contact between a male-type member such
25 as quasi-spherical member 20 and walls of the bore will be sufficient to crush or to otherwise deform surface features of the male-type member and/or surfaces or walls within the female bore. The shape of the bore 43 including its walls 44 and the shape and surface features of the quasi-spherical member 20 can be such that the quasi-spherical member can be positionable in the bore of the humeral head
30 member for removably locking the quasi-spherical member to the humeral head member, e.g., providing a fixed immovable connection between the quasi-spherical member 20 and the humeral head 40.

[0055] The quasi-spherical member 20 is disposed at a proximal end of the fixation member 60. In this particular embodiment, the humeral prosthesis 10 can include a narrowing and connecting member 37 which can form a transition between the quasi-spherical member 20 and the fixation member 60. This
5 connecting member 37 can be sized and shaped to provide clearance for adjustment of the humeral head 40 on the quasi-spherical member 20. The humeral head 40 can include a cannulation 55 providing an opening extending from the base 48 of the bore 43 to the convex articulating surface 47. The
10 cannulation 55 can be used for insertion of a pin-like tool (not pictured) to separate the humeral head 40 from the quasi-spherical member 20 after the two members have been fixedly attached by impact loading. In another example, the cannulation 55 can be threaded to use in conjunction with a bolt (not pictured) to separate the humeral head member 40 from the quasi-spherical member 20. Although the bore 43 is illustrated as positioned on a center axis 39 of the
15 humeral head 40, the placement of the bore 43 can be offset from the center axis 39 to provide a surgeon with additional configurations for the humeral prosthesis 10.

[0056] FIG. 2 shows a perspective view of another example of a humeral head member 40. The bottom side 42 can include a recessed area 49 which can
20 provide a humeral head member 40 with a lighter weight and/or greater orientation adjustment.

[0057] FIG. 3A shows a cross-section of a humeral head 40. The bore 43 can be tapered to include a first radius 45 positioned near the bottom side 42 and a second radius 46 positioned near the base 48. While not necessary, the first
25 radius 45 and the second radius 46 can be related to measurements on the quasi-spherical member 20 (See FIG. 3C). FIG. 3B illustrates a perfect sphere 21 having a radius 23. FIG. 3C illustrates a quasi-spherical member 20 that includes an illustrative textured outer surface 11 covering essentially the entirety of the quasi-spherical member 20. In accordance with certain aspects of the present
30 disclosure, quasi-spherical members or other male-type connectors in accordance with the present disclosure will incorporate a textured outer surface covering more than 50%, or more than 65%, or more than 75%, or more than 85% of the quasi-spherical member or another connector. In some instances, the

textured outer surface will cover between about 25% and about 50% of the quasi-spherical member or another connector, or between about 35% and about 75%, or between about 50% and about 90%, or between about 60% and about 100%.

5 [0058] Continuing with FIG. 3C, this particular textured outer surface 11 incorporates a tessellation pattern 80 that can be three-dimensional. A suitable tessellation can incorporate a plurality of polygonal elements such as polygonal elements 78. In this particular instance, the polygonal elements are triangular elements or faces 81. Textured outer surfaces according to additional aspects of
10 the present disclosure can incorporate other suitable three-dimensional tessellations. In certain embodiments, quasi-spherical members or other male-type connectors in accordance with the present disclosure will mimic or approximate a plurality of stacked polyhedra such as but not limited to stacked cubes, rhombic dodecahedrons, truncated octahedrons, hexagonal prisms, or
15 triangular prisms. In some forms, quasi-spherical members or other male-type connectors in accordance with the present disclosure will mimic or approximate a honeycomb of polyhedral cells including uniform and non-uniform honeycombs.

[0059] Continuing with FIG. 3C, the textured outer surface 11 includes a
20 plurality of outermost extensions 12 which in this illustrative embodiment occur at vertices of the triangular faces as discussed hereinbelow. A distance from the center of the quasi-spherical member 20 to an outermost extension 12 can be equal to the first radius 45. While not necessary, an arc connecting at least two of the outermost extension 12 can generally have the same curvature as the arc
25 of the perfect sphere 21. The textured outer surface 11 includes a plurality of innermost depressions 13 which in this illustrative embodiment occur at the centers of the triangular faces as discussed hereinbelow. A distance from the center of the quasi-spherical member 20 to an innermost depression 13 can be equal to the second radius 46. While not necessary, an arc connecting at least
30 two of the innermost depressions can generally have the same curvature as the arc of the perfect sphere 21. A secure grip between the textured outer surface 11 and inner walls 44 of the bore can occur at one or more interfaces 22. While not necessary, the relationship between the first radius 45 and the second radius 46

can be as follows: where R = a radius 23 of a perfect sphere 21, the first radius 45 = $R+t$ and the second radius 46 = $R-t$ where “ t ” is a variable that can be changed to create a broad range of textured outer surfaces 11.

[0060] FIGS. 4A-D illustrate a spectrum of densities of tessellation patterns 80. FIG. 4A provides a quasi-spherical member 20 with a low density 28 of polygonal elements 78. FIG. 4D provides a quasi-spherical member 20 with a high density 27 of polygonal elements 78. FIGS. 4B-4C illustrate quasi-spherical members 20 with lower and higher intermediate densities 29 of polygonal elements 78. A quasi-spherical member 20 with a higher density will allow a higher quality of spherical mapping. As the quasi-spherical member 20 is being adjusted in the walls 44 of the bore 43 (see FIGS. 1A-B), the higher quality mapping can allow a greater spectrum of possible orientations or angular positions of the humeral head member 40 in relation to the quasi-spherical member 20.

[0061] FIG. 4A shows features of the polygonal elements 78. An individual polygon 86 can have an exterior face 87 that forms an outer surface on the quasi-spherical member 20. The exterior face 87 can include a chord 89 as an edge of the exterior face 87. Each chord 89 can be contiguous with a chord 89 of a neighboring polygon 79. The chord 89 can terminate at each end in a vertex 88. Each vertex 88 of a polygon 86 can be contiguous with a vertex 88 of a neighboring polygon 79. Any number of these exterior surface features (e.g., edges, chords, planar or non-planar faces, vertices, etc.) and/or any of the other exterior surface features disclosed herein that can be incorporated into a textured outer surface of a male-type connecting members can forcibly contact walls or surfaces in a female-type bore to some degree, and in some instances, can be formed with materials that cause such surface features to be crushed or to otherwise deform upon such forcible contact, to removeably lock or help to removeably lock the male-type connecting member in the bore. Just to give one illustrative example, a plurality of planar or nearly planar faces on a textured outer surface of a male-type connecting member (e.g., a quasi-spherical member) can each partially contact a curved wall of a female bore (e.g., cylindrical or conical).

[0062] In accordance with certain aspects of the present disclosure, quasi-spherical members or other male-type connectors in accordance with the present disclosure will incorporate a textured outer surface that includes a plurality of generally planar surfaces, for example, where the combined area of the generally planar surfaces cover more than 50%, or more than 65%, or more than 75%, or more than 85% of the quasi-spherical member or another male-type connecting member. In some instances, the combined area of the generally planar surfaces will cover between about 25% and about 50% of the quasi-spherical member or other male-type connecting member, or between about 35% and about 75%, or between about 50% and about 90%, or between about 60% and about 100%.

[0063] Referring now to FIG. 5A, shown is a quasi-spherical member 20 according to another embodiment of the present disclosure that could be incorporated into any suitable orthopedic system or implant. On what would otherwise be a perfect sphere, a textured outer surface 11 in this instance includes a plurality of planar, circular faces 82 which are spaced from one another on the quasi-spherical member. These types of planar faces can have any suitable perimeter shape, e.g., incorporating rectilinear and/or curvilinear features. Illustratively, in additional embodiments, a textured outer surface will include a plurality of planar surfaces that are non-circular, e.g., polygonal. One example of this is the tessellated surface pattern shown in FIG. 3C. Additionally, it will be understood that when a textured outer surface in accordance with the present disclosure incorporates circular and/or non-circular exterior faces, such faces need not be planar. Illustratively, in additional embodiments, a textured outer surface will include a plurality of non-planar surface elements that are spaced from one another on the quasi-spherical member or another male-type connecting member. Such surface elements can be convex or concave or can incorporate other three-dimensionally curved surfaces. For example, one or more of the planar, circular faces 82 shown in FIG. 5A could instead be slightly convex or slightly concave. Additionally, it will be understood that any two such circular or non-circular surface elements need not be spaced from one another on a textured outer surface of a male-type connecting member. Select surface elements can be contiguous with one another or otherwise contact one another

on the textured outer surface. FIG. 5B shows a quasi-ellipsoid member 85 according to one embodiment of the present disclosure that could be incorporated into any suitable orthopedic system or implant. A textured outer surface 11 in this instance includes a plurality of surface elements "X" which
5 can be any of those disclosed herein, e.g., planar and/or non-planar surface elements. For example, any one surface element "X" can be a bump, bulge, lump, knob, protuberance, dimple, depression, dent, or another type of projection or indentation. Such features can be arranged in regular or irregular patterns. These and other surface textures disclosed herein can be formed in any suitable
10 manner including by cutting away, grinding away or otherwise removing material from an initial workpiece to provide one or more surface features or elements, or by welding, adhering or otherwise adding material to an existing piece to provide one or more surface features or elements, or by casting or otherwise initially forming a component (e.g., using an additive manufacturing
15 process) to have one or more surface features or elements.

[0064] FIGS. 6A-B illustrate variations between the flatness of the surface of each exterior face 87 of each polygonal element 78. FIG. 6A shows a quasi-spherical member 20 having polygons 86 that have planar faces 93. FIG. 6B shows a quasi-spherical member 20 having polygons 86 that have arcuate
20 faces 92. The arcuate face 92 can be formed with curves having a very slight radius or formed with curves having a more pronounced radius as discussed elsewhere herein.

[0065] FIGS. 7A-B represent two configurations of an assembly 9 that includes a fixation member 60 and a quasi-spherical member 20. In FIG. 7A the
25 assembly 9 includes at least two separate pieces. The quasi-spherical member 20 can include a connecting member 37 that is unitarily formed with the quasi-spherical member, or alternatively, the connecting member can be a separately-formed piece that is subsequently connected to the quasi-spherical member using any suitable type of connection such as a tapered fit or threaded connection. For
30 example, the quasi-spherical member can include a female-type bore into which a male-type element of the connecting member is received to make a connection. Also, the fixation member 60 can include a stem cavity 76 which can receive a distal end 61 of the connecting member 37 for making a connection between the

two in any suitable fashion. For example, the connection between the connecting member 37 and the fixation member 60 can be in any of the forms disclosed herein including in the form of a locking taper connection, a screw connection, a bolt connection, or a connection employing additional fasteners to facilitate making the connection. For example, the connecting member can have threads to mate with threads in the stem cavity 76. A configuration such as illustrated in FIG. 7A can allow the mixing and matching of various forms of quasi-spherical member/connecting member assemblies with various forms of connecting members and/or fixation members 60 so that a particular patient's morphology can be matched completely.

[0066] FIG. 7B illustrates an example of a monoblock assembly 69 in which the connecting member 37 is not removable from the fixation member. These examples should not be construed as limiting. For example, the connecting member 37 of FIG. 7A could be integrally formed with the fixation member 60 instead of integrally formed with the quasi-spherical member 20. In such a case, the quasi-spherical member 20 would have a cavity to receive a proximal end of the connecting member 37. It is also possible that the fixation member 60 and the quasi-spherical member 20 and any potential intermediate member be formed as a monoblock or otherwise formed together as a single unit.

[0067] FIG. 8 illustrates an example of a humeral member or assembly 9 that includes a stemless member 62. The stemless member 62 could include what is considered a short stem but in any event is not inserted deep into the canal 73 of the humerus 74 and instead is anchored to more proximal portions of a humerus 74 (see FIG. 1C). While not necessary, the stemless member 62 can be connected to a distal end of a connecting member 37, which in turn can be connected at its opposite end to a quasi-spherical member 20.

[0068] As discussed elsewhere herein, in some preferred forms, a textured outer surface of a male-type connector will exhibit or occupy only a portion of a particular shape such as a part of a sphere, part of an ellipsoid, etc. FIG. 9 shows a humeral member or assembly 9 according to one embodiment of the present disclosure. Assembly 9 can include a fixation member 60 and a male-type connector 100. A portion of the connector is shown in phantom as indicated by dashed line 101, and in this regard, it will be understood that connector 100

can have spherical or partial-spherical qualities. For example, in some forms, connector 100 will be a truncated sphere where an illustrative segment 102 of the sphere is removed or never exists as part of the connector. While the degree or amount of truncation shown in FIG. 9 may be useful in certain embodiments, it is merely illustrative of those contemplated. In this truncated version of the connector, segment 102 is defined along a single plane to create a proximal planar surface 103. When present, such a proximal surface can be planar or non-planar. Also, any suitable portion or percentage of such a truncated or another partial shape can be covered by a textured outer surface.

10 [0069] As also discussed elsewhere herein, quasi-spherical members or other male-type connectors in accordance with certain aspects of the present disclosure can incorporate a textured outer surface covering only a certain portion or percentage (e.g., between about 50% and about 90%) of the quasi-spherical member or another connector. Continuing with FIG. 9, in some other forms, one or more connector segments or other connector portions such as segment 102 will be part of the connector but will be void of a textured outer surface such as surface 99 or will have a lesser-textured, differently-textured, etc. outer surface. For example, the illustrative segment 102, when present, can have a generally smooth outer surface. In this regard, while the amount or percentage of coverage by the textured outer surface 99 shown in FIG. 9 may be useful in certain embodiments, it is merely illustrative of those contemplated. Any suitable degree or percentage of coverage by a particular textured outer surface is contemplated, e.g., more than 50%, or more than 65%, or more than 75%, or more than 85%, or between about 25% and about 50%, or between about 35% and about 75%, or between about 50% and about 90%, or between about 60% and about 100% of the quasi-spherical member or other connector.

25 [0070] In some embodiments, a quasi-spherical member or another male-type connector in accordance with the present disclosure is incorporated into an orthopedic product that is to be driven into or otherwise received in bone, for example, as a product for attaching or securing another orthopedic device such as a bone plate or implant to bone. In some of these embodiments, the orthopedic product is a bone screw, for example, where a quasi-spherical member or other male-type connector is disposed at a location along the length of the screw such

as at a location between the ends of the screw or at or near the end of a screw to form all or part of a screw head. Such products can be formed with any suitable material(s), and in some instances, will include an exterior surface that encourages bone ongrowth or ingrowth, for example, including a blasted surface
5 to encourage bone ongrowth.

[0071] With reference now to Figure 10, shown is a bone screw 120 that includes a quasi-spherical member 121 disposed at a proximal end 122 of the screw to provide a screw head 123. In this particular embodiment, a female bore 125 with a hexagonal cross-section extends into the head from a proximal
10 surface 126 of the head. Bone screw 120 also includes a shaft 128. While this sort of a quasi-spherical bone screw head can be paired with a bone screw shaft of any suitable size, shape or configuration, in this particular instance, the shaft extends distally from the proximal end 122 (e.g., head of the screw) to a leading, distal tip 130 of the screw. A central cannula 131 continues on from female bore
15 125 and traverses the entire length of the screw which can be useful, for example, for placing the screw over a positioned K-wire. Bone screws and fasteners in accordance with the present disclosure can be fully or partially cannulated or non-cannulated. Cannulated regions can have any suitable wall thickness.

[0072] Continuing with Figure 10, shaft 128 includes a proximal section 133 having a first diameter and a distal section 134 having a second diameter that is smaller than the first diameter. Bone screw and fastener shafts in accordance with the present disclosure can have constant diameters or cross-sections along their lengths, or a shaft diameter or cross-section can vary along
25 its length. For example, any section of a shaft can be tapered or non-tapered. Thus, proximal section 133 and/or distal section 134 can be fully or partially tapered along its length. While not necessary to broader aspects of the disclosure, a dual- or other multi-diameter or cross-section shaft can be useful in a variety of instances, for example, where shaft sections with different diameters or cross sections are intended to reside in different types or areas of bone. For
30 example, when bone screw 120 is placed in a glenoid, this sort of dual-diameter arrangement can account for the smaller volume of bone or a minimum cross-section of the bone anatomy (e.g. blade of scapula) located away from the point

of entry of the screw as well as the comparatively larger volume of available bone located closer to the entry point (e.g. glenoid vault). In this regard, proximal section 133 can be considered a glenoid vault zone, and distal section 134 can be considered a glenoid blade zone of screw 120 if the screw happens to
5 be placed in this particular anatomy.

[0073] Continuing with Figure 10, threading 135 (not shown for clarity reasons) which can have a consistent screw pitch extends along both the proximal and distal sections of the shaft. Bone screws and fastener shafts in accordance with the present disclosure can be fully or partially threaded or non-
10 threaded. Any suitable threading can be employed, and a screw or fastener can have different types of threading at different locations along a shaft. Above are just a few non-limiting examples of how a quasi-spherical member or another male-type connector in accordance with the present disclosure can be paired with a shaft of any suitable size, shape or configuration including self-drilling or
15 self-tapping shafts.

[0074] A quasi-spherical member or another male-type connecting member of a bone screw or other fastening-type device in accordance with the present disclosure can be used with (e.g., received and locked in a bore present
20 in) any number of implants or other orthopedic devices disclosed elsewhere herein. These include plates (e.g., bone plates) and other non-plate orthopedic devices. One or more bone screws or other fastening-type devices in accordance with the present disclosure can be utilized in any one device. Figure 11 is illustrative of one such device and shows, for example, how different angular
25 positions X and Y can be achieved and maintained using connections according to aspects of the present disclosure. In particular, Figure 11 depicts an orthopedic assembly 140 that includes an orthopedic device 141 (e.g., a bone plate or implant) that provides a first tapered female bore 142 and a second, identical tapered female bore 143 with walls 144. These particular bores have a shape of a frustum of a right circular cone. Although not necessary to broader aspects of the
30 disclosure, the bores each extend entirely through a wall or section 145 of the device. Either bore could have any suitable size and shape. As disclosed elsewhere herein, a suitable female bore can be tapered or non-tapered and can otherwise be or incorporate any suitable three-dimensional shape, e.g.,

incorporating rectilinear and/or curvilinear features. Continuing with Figure 11, assembly 140 also includes a first bone screw 146 and an identical second bone screw 147. Each screw includes a quasi-spherical head 148 and a shaft 149 extending from the head. These heads and shafts could be any combination of
5 heads and shafts disclosed herein. In use, the leading ends of the shafts can be passed into and through the bores. In the Figure 11 illustration, this passing occurs in a downward direction, i.e., the leading ends enter the frustoconical bores through the larger top ends of the bores and exit the smaller bottom ends. Thereafter, the screws can be advanced (e.g., into bone) until the quasi-spherical
10 heads are received down into the respective female bores and locked therein to generate the different angular positions X and Y. Based on the Figure 11 orientation, seating can also be fully or partially accomplished by moving the bores in an upward direction relative to the heads. Although not necessary to broader aspects of the disclosure, the walls of the bores extend fully around the
15 seated heads, e.g., with no breaks or openings in the walls that form the frustoconical bore shapes.

[0075] Figure 12 shows a front view of an orthopedic assembly according to another embodiment of the present disclosure, and shows, for example, how different angular positions X and Y can be achieved and
20 maintained using connections according to aspects of the present disclosure. In particular, Figure 12 depicts an orthopedic assembly 140 that includes an orthopedic device 141 (e.g., a bone plate or implant) that provides a first tapered female bore 142' and a second, identical tapered female bore 143' with walls 144'. These particular bores have a shape of a frustum of a right circular cone.
25 Although not necessary to broader aspects of the disclosure, the bores each extend entirely through a wall or section 145 of the device. Either bore could have any suitable size and shape. As disclosed elsewhere herein, a suitable female bore can be tapered or non-tapered and can otherwise be or incorporate any suitable three-dimensional shape, e.g., incorporating rectilinear and/or
30 curvilinear features. Such bores could extend only partially through the wall or section, for example, as shown with the elongated bore or opening in Figure 13C. Continuing with Figure 12, assembly 140 also includes a first bone screw 146 and an identical second bone screw 147. Each screw includes a quasi-

spherical head 148 and a shaft 149 extending from the head. These heads and shafts could be any combination of those disclosed herein. In use, the quasi-spherical heads can be received and locked in the respective female bores to generate the different angular positions X and Y. Based on the Figure 12 illustration, such connections can be achieved by moving wall or section 145 in a downward direction onto the screws (e.g., by impacting the device 141) so that the heads enter the frustoconical bores through the larger bottom ends of the bores and move a distance in the bores toward the smaller top ends until suitably locked in place. Based on the Figure 12 orientation, seating can also be fully or partially accomplished by moving quasi-spherical heads 148 in an upward direction relative to the bores. In this regard, depending on the sizes and shapes of the various components, it is possible to make the connections with no portions of the shafts ever entering the bores. Although not necessary to broader aspects of the disclosure, the walls of the bores extend fully around the seated heads, e.g., with no breaks or openings in the walls that form the frustoconical bore shapes. In some forms, a screw will be advanced to a desired final location in a bone before a quasi-spherical screw head is locked in a female bore of a device, for example, where a plate is impacted down onto a pre-positioned screw so that the quasi-spherical member is forcefully received and locked in the female bore.

[0076] Turning now to Figure 13A, shown is a top view of an orthopedic plate 200 according to one embodiment of the present disclosure. From this view, plate 200 is shown to include a generally rectangular bore or opening 201. Although not necessary to broader aspects of the disclosure, the rectangular opening extends entirely through the plate, i.e., in a direction into the page based on the Figure 13A illustration. Such an opening can be an elongated or slot-type opening of any suitable size and rectangular or non-rectangular shape. A plate or other device can incorporate any number of such openings. Illustratively, such an opening can have one dimension (e.g., rectangular slot length when viewed from the top as in Figure 13A) that is significantly larger than another dimension (e.g., rectangular slot width) including but not limited to a first dimension that is 2 to 40, or 4 to 20, or 8 to 15 times larger than a second dimension. An elongated or slot-type opening can have a curvature along its length, for example, even

providing in some embodiments an annular or ring-shaped slot with no ends. Also, although the width of the opening 201 in Figure 13A is constant along its length, it need not be. Such a slot can be a series of discernable openings or bores like those shown in Figures 11 and 12 which are interconnected across a
5 plate or other device, for example, interconnected by slots or passages of a smaller width or dimension that allow interbore movement of another assembly component such as horizontal movement of a screw or fastener shaft from one bore to another along a plate or other device before the screw or fastener is ultimately locked in place in a particular bore. Any such elongated or slot-type
10 opening can be part of any plate or non-plate orthopedic device in accordance with the present disclosure.

[0077] Figure 13B shows a cross-sectional view taken along view line 13B-13B from FIG. 13A, and it can be seen that walls 202 of the opening are angled or tapered. Based on the Figure 13B orientation, the walls diverge
15 moving from top to bottom so that the top end of the opening 201 is smaller than the bottom end of the opening. Based on the Figure 13B illustration, a connection with a quasi-spherical member or another male-type connector in accordance with the present disclosure can be achieved by moving plate 200 in a downward direction onto the quasi-spherical member (e.g., which forms all or
20 part of a screw head) so that the quasi-spherical member enters the opening through the larger bottom end of the opening and moves a distance in the opening toward the smaller top end until suitably locked in place. Alternatively, the plate could be flipped over from what is shown in Figure 13B, and a leading tip of a screw could be passed into and through the opening, and the screw could
25 be advanced until a quasi-spherical head of the screw is locked into the opening.

[0078] That such openings can have an elongated or slot-type shape allows a quasi-spherical member such as that of the screw shown in Figure 10, prior to being locked in place, to be moved to different relative positions along the length of a slot or other opening. For example, when viewing the Figure 13A
30 illustration, such a quasi-spherical member could be received and locked in place in the opening at or near one end of the opening, at or near the far opposite end of the opening, or anywhere in between. Although not necessary to broader aspects of the disclosure, at opposite ends of the rectangular opening, the

opening 201 is tapered on three sides. Alternatively, the illustration of Figure 13B can represent one end of plate 200 such that it is not a cross-sectional view of plate 200 but rather an end view. In this regard, a quasi-spherical member could be partially and loosely received in the opening, and the plate could be slid
5 over a quasi-spherical member (e.g., from the side) before a connection is made. Such a configuration could be particularly useful, for example, where space is limited anatomically such as where it is not easy or possible to introduce a plate or device other than from the side. Such side openings could be located anywhere on a plate or other device.

10 [0079] Figure 13C shows part of an orthopedic plate 210 according to another embodiment of the present disclosure. Plate 210 includes a top surface 211 and bottom surface 212. This plate is similar to that shown in Figure 13B except that it includes an opening 213 which extends only partially through the plate, and in this regard, Figure 13C represents a cross-sectional view of the
15 plate taken from a similar vantage point as the cross-sectional view in Figure 13B. In particular, opening 213 extends into the plate from bottom surface 212, and walls 214 of the opening converge moving toward the top surface 211 of the plate. Alternatively, the illustration of Figure 13C can represent one or both
20 an end view. In this regard, a quasi-spherical member could be partially and loosely received in the opening, and the plate could be slid over a quasi-spherical member (e.g., from the side) before a connection is made. Such a configuration could be particularly useful, for example, where space is limited anatomically
25 from the side. Such side openings could be located anywhere on a plate or other device.

[0080] FIG. 14 illustrates an embodiment of an implant assembly 300 for a total shoulder joint replacement. While the implant assembly 300 is illustrated in the drawings as a reverse shoulder prosthesis, other shoulder prostheses are
30 contemplated. The implant assembly 300 is configured to be implanted between a resected humerus 302 and a glenoid cavity (“glenoid”) 304 of a scapula 306 in a reverse arthroplasty. The implant assembly 300 can include a head member 308 (henceforth: “head”), a humeral tray assembly 310, and an adapter 311. The

humeral tray assembly 310 can include a humeral tray member 312 (henceforth: “tray”) and an articulating liner member 314 (henceforth: “liner”). The implant assembly 300 may also include a fixation member 316 that has a proximal end 318 and a distal end 320.

5 [0081] In the embodiment shown in FIG. 14, the head 308 can be bounded by a convex surface 322, which may be, for example, a hemispherical surface, and a base 324, which may be a substantially planar surface. In one embodiment, the base 324 may be modularly connected to the head 308. A female taper 326 with tapered inner walls 328 can extend from the base 324 into
10 the head 308. The convex surface 322 of the head 308 can be shaped to articulate with a concave surface 330 of the liner 314 to allow for shoulder joint movement. Such articulation may be centered or eccentric.

[0082] In one embodiment, the adapter 311 may include an adapter tray 332 and an extension or male taper 334 that can be press-fitted into the female
15 taper 326 of the head 308. For the procedure of reverse arthroplasty, the adapter tray 332 can be attached to the glenoid 304.

[0083] Referring to FIG. 14, the tray 312 can include a bottom side 336 that can include a tray stem 338. The tray stem 338 can be any structure that extends from the bottom side 336 and can be configured in a variety of lengths
20 and shapes to provide for patient anatomies of different sizes and shapes. The tray stem 338 can include any feature or any combination of features such as described for the connecting member 37 in FIGS. 1, 7, and 8. A quasi-spherical member 340 such as a quasi-spherical member having any feature or any combination of features of the quasi-spherical members described in FIGS. 1-13
25 can be coupled adjacent the distal end 339 (see FIG. 15) of the tray stem 338 and can be configured to be selectively coupled to the fixation member 316 in a reverse shoulder arthroplasty, or other joint replacement procedure. The fixation member 316 can extend from a distal end 320 to a proximal end 318. A bore 342 can be defined in the proximal end 318. The bore 342 can be tapered and can
30 include all the features relating to any or any combination of the features of bores 43 or 143 described above. In addition, the bore 342 can include any or any combination of the features of bores 43 or 143 described above as they relate to the quasi-spherical member 340.

[0084] The quasi-spherical member 340 can be located in the bore 342. An angle of the tray 312 relative to the fixation member 316 can be adjusted in three dimensions. Once the tray 312 is deemed by a surgeon to be suitably oriented, the quasi-spherical member 340 can then be more fully inserted into the bore 342, e.g., by impaction loading accomplished by pressure, impact force or otherwise. In some instances, forcible contact between a male-type member such as the quasi-spherical member 340 and walls of the bore 342 will be sufficient to crush or to otherwise deform surface features of the male-type member and/or surfaces or walls within the bore 342. The shape of the bore 342 including its walls 344 and the shape and surface features of the quasi-spherical member 340 can be such that the quasi-spherical member 340 can be positionable in the bore 342 of the fixation member 316 for removably locking the quasi-spherical member 340 to the fixation member 316, e.g., providing a fixed immovable connection between the quasi-spherical member 340 and the fixation member 316.

[0085] In an example, surfaces of the proximal end 318 of the fixation member 316 and/or the proximal end of the resected humerus 302 can be modified or adjusted to enable additional angular adjustment of the tray 312 relative to the fixation member 316.

[0086] FIG. 15 shows a perspective view of a humeral tray assembly 310, according to at least one embodiment of the present disclosure. The humeral tray assembly 310 can generally include a tray 312, a liner 314, and a retaining ring 346. As will become appreciated, the retaining ring 346 can be adapted to retain the liner 314 relative to the tray 312 in a locked position.

[0087] The tray 312 can include a top side 313 that can generally define a tray member cavity 348 that can form a recess configured to receive the liner 314. Note: although the terms top side 313 and bottom side 336 have been used in this description, this is for explanation purposes only and the orientation of the tray 312 can be any three-dimensional orientation, limited only in that “top side 313” and “bottom side 336” are two generally opposing surfaces. The tray 312 can generally include a platform portion 350 and a tray stem 338. The platform portion 350 can have an upper rim 352. The tray 312 can have a liner engaging surface 354. The tray 312 may comprise a biocompatible metal, such as stainless

steel, titanium, titanium alloys, and cobalt-chromium alloys. In an alternative, the tray 312 can comprise any biocompatible material. The upper rim 352 can have a first interlocking portion 356. In the example shown, the first interlocking portion 356 is in the form of tabs 358 radially positioned around the upper rim 5 352. The tabs 358 can generally be raised relative to the upper rim 352. The platform portion 350 can further define an inboard annular groove 360 formed around the liner engaging surface 354. The upper rim 352 can further include a first slot 362. In one example, the first slot 362 can include a generally planar surface or ledge 364 that is transverse to a long axis of the tray stem 338. Fingers 10 366 of the retaining ring 346 can engage the first slot 362. Portions of the tray 312 can include bone engaging surfaces having a porous coating.

[0088] The liner 314 will now be described in greater detail. The liner 314 may be formed of polyethylene or other suitable bearing material. The liner 314 can generally include an outer tray engaging surface 368 and an inner head 15 engaging surface 370. An outboard annular groove 369 can be formed around the outer tray engaging surface 368. The outer tray engaging surface 368 can have a generally planar surface, while the inner head engaging surface 370 can be generally concave. A second interlocking portion 372 can be formed around a rim portion 371 of the liner 314. In the example shown, the second interlocking 20 portion 372 is in the form of complementary notches 374 defined around the rim portion 371. The first and second interlocking portions 356 and 372 can cooperatively mate in an assembled position (FIG. 16), such that the tabs 358 nest with the notches 374 and, therefore, inhibit rotational motion of the liner 314 within the tray 312. In the particular example shown, the amount of notches 25 374 equals the amount of tabs 358. It is appreciated however, that in other examples, the notches 374 may outnumber the tabs 358.

[0089] The retaining ring 346 can be adapted to locate within the inboard 30 annular groove 360 of the tray 312. In a locked position, the inboard annular groove 360 of the tray 312 is operable to snappingly receive the retaining ring 346 to secure the liner 314 to the tray 312. Explained further, the retaining ring 346 can be adapted to partially nest within the inboard annular groove 360 of the tray 312 and, concurrently, partially nest within the outboard annular groove 369 of the liner 314 in the locked position (FIG. 16). An annular protrusion 376 of

the retaining ring 346 can nest within a second slot 378. In this way, the retaining ring 346 may be discouraged from rotating around the platform portion 350 of the tray 312.

5 [0090] The quasi-spherical member 340 can be coupled to or integral formed with a distal end 339 of the tray stem 338 (see FIG. 16).

[0091] FIG. 16 shows a cross section of a humeral tray assembly 310, according to at least one embodiment of the present disclosure. The quasi-spherical member 340 can include any of the shapes, surfaces, materials, forms, qualities, and/or functions described above in FIGS. 1-13. The tray 312 can
10 define one or more recesses 380A, 380B in the bottom side 336 that can be configured to allow greater angular movement of the tray 312 relative to the fixation member 316 (see FIG. 14) when the desired orientation of the tray 312 is being set by a surgeon. FIG. 16 shows the liner 314 installed in the tray 312 and held in place by the retaining ring 346 in the outboard annular groove 369 and the inboard annular groove 360. The ledge 364 is shown.
15

[0092] The tray stem 338 can be configured in a variety of lengths to adapt the humeral tray assembly 310 for different amounts of angular adjustment, and/or different patient anatomies.

[0093] Although the humeral tray assembly 310 has been described in
20 detail above, the present inventor has contemplated other forms that may include different contours, subassemblies, and/or additions (e.g., spacers), forms (e.g., one piece tray and liner assembly) without changing the intent of this disclosure.

[0094] FIG. 17 shows a tray 312 engaged with a fixation member 316, according to at least one embodiment of the present disclosure. The fixation
25 member 316 can include a threaded bore 382. The tray stem 338 can include a stem bore 384. Portions of the stem bore 384 can be threaded, or the stem bore 384 can be unthreaded. The stem bore 384 can extend from the liner engaging surface 354 (see FIG. 15) to the tip 386 of the quasi-spherical member 340. If no angular adjustment of the tray 312 is required, a fastener (not shown) can extend
30 through the stem bore 384 into the threaded bore 382 and can attach the tray 312 to the fixation member 316. Although the quasi-spherical member 340 is shown located near the bore base 390 of the bore 342, the quasi-spherical member 340 can be configured to fit at other locations of the walls 344 of the bore 342 (e.g.,

by altering the diameter of the quasi-spherical member 340 and/or the bore 342). The walls 344 can be tapered, shaped, or formed in manners described above in relation to bore 43 and/or bore 143.

[0095] FIG. 18 shows a tray 312 engaged with a fixation member 316, according to at least one embodiment of the present disclosure. FIG. 18 shows the relationship between the fixation member 316 and the tray 312 at a first angle 392 and FIG. 19 shows the relationship between the fixation member 316 and the tray 312 at a second angle 394. FIG. 18 shows a top edge 396 that is generally in the same plane along both sides of the bore 342. In FIG. 19, the top edge 396 can be configured to be recessed, angled, or cut away, for example at portion 398 so that the second angle 394 can be increased without interfering with the bottom side 336 of the tray 312. The tray stem 338 in FIG. 19 is shorter than the tray stem 338 of FIG. 18 and the tray 312 can be provided with tray stems 338 of various lengths to accommodate different anatomies, surgical procedures, and/or angular adjustments.

[0096] FIG. 20 shows a tray 312 engaged with a fixation member 316, according to at least one embodiment of the present disclosure. In an embodiment, one or both of the tray stem 338 and the quasi-spherical member 340 do not include a stem bore 384 (see FIG. 17) and can be solid material.

[0097] FIG. 21 shows a humeral tray assembly 400 having an internal bore 402, according to at least one embodiment of the present disclosure. The humeral tray assembly 400 can include a tray 412 and a liner 414. The tray 412 can include an internal bore 402, having tapered walls 404 and configured to operate as the bore 43 described in FIGS 1-9. The internal bore 402 can engage a quasi-spherical member 20 located on a fixation member 60 as described in FIGS. 1-9. The humeral tray assembly 400 can be angularly adjusted in the same manner as the humeral head member 40 described above in FIGS. 1-9.

[0098] FIG. 22 shows an implant assembly for a total shoulder joint replacement, according to at least one embodiment of the present disclosure.

[0099] While the implant assembly 500 is illustrated in the drawings as a reverse shoulder prosthesis, other shoulder prostheses are contemplated. The implant assembly 500 is configured to be implanted between a resected humerus 502 and a glenoid cavity (“glenoid”) 504 of a scapula 506 in a reverse

arthroplasty. The implant assembly 500 can include a head member 508 (henceforth: "head"), a humeral tray assembly 510, and an adapter 511. The humeral tray assembly 510 can include a humeral tray member 512 (henceforth: "tray") and a liner member 514 (henceforth: "liner"). The implant assembly 500
5 may also include a fixation member 516 that has a proximal end 518 and a distal end 520. The fixation member 516 can extend from a distal end 520 to a proximal end 518. A bore 542 can be defined in the proximal end 518.

[00100] In the embodiment shown in FIG. 22, the head 508 can be bounded by a convex surface 522, which may be, for example, a hemispherical surface, and a base 524, which may be a substantially planar surface. In one
10 embodiment, the base 524 may be modularly connected to the head 508. A female taper 526 with tapered inner walls 528 can extend from the base 524 into the head 508. The female taper 526 can include all the features relating to any or any combination of the features of bores 43 or 143 described above. The convex
15 surface 522 of the head 508 can be shaped to articulate with a concave surface 530 of the liner 514 to allow for shoulder joint movement. Such articulation may be centered or eccentric.

[00101] In one embodiment, the humeral tray assembly 510 can be fixed to the resected humerus 502, by means of fasteners, adhesives, or press fit. The
20 tray 512 can include a bottom side 536 that can include a tray stem 538. The tray stem 538 can be any structure that extends from the bottom side 536 and can be configured in a variety of lengths and shapes to provide for patient anatomies of different sizes and shapes. The tray stem 538 can include any feature or any combination of features such as described for the connecting member 37 in
25 FIGS. 1, 7, and 8. The tray stem 538 can be bonded, press fit, or fastened into a bore 542 that can be defined in the proximal end 518. The bore 542 can be tapered and can include all the features relating to any or any combination of the features of bores 43 or 143 described above.

[00102] In one embodiment, the adapter 511 may include an adapter tray
30 532. The adapter tray 532 can include an adapter stem 535. The adapter stem 535 can be configured as any structure that extends from the adapter tray 532 and can be configured in a variety of lengths and shapes to provide for patient

anatomies of different sizes and shapes. For the procedure of reverse arthroplasty, the adapter tray 532 can be attached to the glenoid 504.

[00103] A quasi-spherical member 540 such as a quasi-spherical member having any feature or any combination of features of the quasi-spherical members described in FIGS. 1-13 can be coupled adjacent a distal end of the adapter stem 535 and can be configured to be selectively coupled to the head 508 in a reverse shoulder arthroplasty, or other joint replacement procedure.

[00104] The quasi-spherical member 540 can be located in the female taper 526. An angle of the head 508 relative to the adapter 511 can be adjusted in three dimensions. Once the head 508 is deemed by a surgeon to be suitably oriented, the quasi-spherical member 540 can then be more fully inserted into the female taper 526, e.g., by impaction loading accomplished by pressure, impact force or otherwise. In some instances, forcible contact between a male-type member such as the quasi-spherical member 540 and walls of the female taper 526 will be sufficient to crush or to otherwise deform surface features of the male-type member and/or surfaces or walls within the female taper 526. The shape of the female taper 526 including its tapered inner walls 528 and the shape and surface features of the quasi-spherical member 540 can be such that the quasi-spherical member 540 can be positionable in the female taper 526 of the head 508 for removably locking the quasi-spherical member 540 to the head 508, e.g., providing a fixed, immovable connection between the quasi-spherical member 540 and the fixation head 508.

[00105] In an example, surfaces of the glenoid cavity 504 can be modified or adjusted to enable additional angular adjustment of the adapter 511 relative to the head 508.

[00106] FIGS. 23-26 illustrate examples of an implant assembly 600 for a total shoulder joint replacement, according to at least one embodiment of the present disclosure. While the implant assembly 600 is illustrated in FIGS. 23-26 as a reverse shoulder prosthesis, other shoulder prostheses are contemplated, and the devices/methods illustrated that include more than one quasi-spherical member can be used in other joint replacement applications and other angularly adjustable fastening applications.

- [00107] The implant assembly 600 shown in FIGS. 23-26 can be similar to the implant assembly 500 described above in conjunction with FIG. 22. FIG. 23 illustrates the implant assembly 600 that can include a head 608, an adapter, 611, an adapter tray 632, an adapter stem 635 and a quasi-spherical member 640.
- 5 The head 608 can define a female taper 626 that can include tapered inner walls 628. The quasi-spherical member 640 can include any or any combination of the features of quasi-spherical members described above. In addition, the quasi-spherical member 640 can define a tip taper 641 which can extend from an outer surface of the quasi-spherical member 640 towards the adapter stem 635.
- 10 [00108] The implant assembly 600 can include a secondary locking system 699 that can allow a secondary securement of the head 608 to the quasi-spherical member 640. The secondary locking system 699 can include a head 608 having a pin bore 650 that extends from a convex surface 622 to the female taper 626. The pin bore 650 can include a lip 651 that can narrow a portion of
- 15 the pin bore 650. The secondary locking system 699 can include a locking pin 652. The locking pin 652 can include a pin base 653. A pin stem 654 can extend from the pin base 653 and can include a pin quasi-spherical member 655 opposite the pin base 653. The pin quasi-spherical member 655 can include any or any combination of the features of quasi-spherical members described above.
- 20 [00109] The locking pin 652 can be configured to pass at least partially through the pin bore 650. The lip 651 can form a shoulder to prevent the pin base 653 from passing through the pin bore 650 and the pin base 653 can rest against the lip 651 as shown in FIG. 25.
- [00110] As shown in FIG. 24, the head 608 can be located on the quasi-spherical member 640. As described above, the head 608 can be angularly adjusted, and when an angle is accomplished the head 608 can be impacted so that the female taper 626 and the quasi-spherical member 640 are joined in a manner that keeps the head securely at the desired placement angle. As shown in FIG. 24, the pin bore 650 can generally align with the tip taper 641. At least
- 25 portions of the diameter of the pin bore 650 can be greater than the diameter of the tip taper 641. Having a greater diameter of the pin bore 650 can allow the pin quasi-spherical head 655 to be located within the tip taper 641 when the head
- 30 608 has been adjusted to the desired placement angle.

[00111] FIG. 25 illustrates the locking pin 652 installed in the pin bore 650. The pin quasi-spherical member 655 can be located in the tip taper 641. The connection between the pin quasi-spherical member 655 and the tip taper 641 can include any of the features of the connections described above with tapered bores and quasi-spherical members. In an example, the locking pin 652 can be installed into the tip taper 641 before the head 608 has been impacted and locked onto the quasi-spherical member 640. In an example, the locking pin 652 can be installed into the tip taper 641 after the head 608 has been impacted and locked onto the quasi-spherical member 640.

10 [00112] FIG. 26 illustrates an implant assembly 600 in which the head 608 has been adjusted so that a base 624 can form an angle 656 with the adapter tray 632. When a desired angle 656 or location of the head 608 relative to the adapter tray 632 has been found, the pin quasi-spherical member 655 can be locked into the tip taper 641 by impaction loading accomplished by pressure, impact force or otherwise as described above. The pin quasi-spherical member 655 of the locking pin 652 can provide a holding force that can complement or take the place of the holding force provided by the quasi-spherical member 640.

15 [00113] The above-detailed description includes references to the accompanying drawings, which form a part of the detailed description. Moreover, the embodiments and examples provided herein can be used in any combination or permutation of those elements shown or described (or one or more aspects thereof), either with respect to a particular example (or one or more aspects thereof), or with respect to other examples (or one or more aspects thereof) shown or described herein.

25 [00114] In this document, the terms “a” or “an” are used, as is common in patent documents, to include one or more than one, independent of any other instances or usages of “at least one” or “one or more.” In this document, the term “or” is used to refer to a non-exclusive or, such that “A or B” includes “A but not B,” “B but not A,” and “A and B,” unless otherwise indicated. In this document, the terms “including” and “in which” are used as the plain-English equivalents of the respective terms “comprising” and “wherein.” Also, in the following claims, the terms “including” and “comprising” are open-ended, that

30

is, a system, device, article, composition, formulation, or process that includes elements in addition to those listed after such a term in a claim are still deemed to fall within the scope of that claim. Moreover, in the following claims, the terms “first,” “second,” and “third,” etc. are used merely as labels, and are not
5 intended to impose numerical requirements on their objects.

[00115] The above description is intended to be illustrative, and not restrictive. For example, the above-described examples (or one or more aspects thereof) may be used in combination with each other. Other embodiments can be used, such as by one of ordinary skill in the art upon reviewing the above
10 description. Also, in the above Detailed Description, various features may be grouped together to streamline the disclosure. This should not be interpreted as intending that an unclaimed disclosed feature is essential to any claim. Rather, inventive subject matter may lie in less than all features of a particular disclosed embodiment.

15

WHAT IS CLAIMED IS:

1. An implant assembly for attachment to a glenoid in a reverse total shoulder arthroplasty, comprising:

a tray member configured for attachment to the glenoid including a tray stem extending from a proximal end to a distal end, the tray stem coupled to the tray member at the proximal end;

a head member including a convex articular surface, an opposing base surface, and a bore that extends through the head member from an opening in the base surface to an opening in the articular surface;

a first quasi-spherical member disposed adjacent the distal end of the tray stem, the first quasi-spherical member positionable through the opening in the base surface and into the bore of the head member for removably locking the first quasi-spherical member to the head member, wherein the first quasi-spherical member includes a textured outer surface for contacting walls of the bore;

a locking pin including a pin base and a pin stem extending from a proximal end to a distal end, the pin stem coupled to the pin base at the distal end; and

a second quasi-spherical member disposed adjacent the proximal end of the pin stem, the second quasi-spherical member positionable through the opening in the articular surface and into a bore formed within the first quasi-spherical member for providing additional securement of the head member to the first quasi-spherical member.

-2. The implant assembly of claim 1, wherein the bore of the head member includes a tapered segment.

3. The implant assembly of claim 1 or 2, wherein the textured outer surface covers more than 50% of the first quasi-spherical member.

4. The implant assembly of any one of claims 1 to 3, wherein the textured outer surface includes a plurality of generally planar faces.

5. The implant assembly of claim 4, wherein the plurality of generally planar faces are spaced from one another on the first quasi-spherical member.
6. The implant assembly of claim 4, wherein the plurality of generally planar faces are contiguous with one another on the first quasi-spherical member.
7. The implant assembly of any one of claims 4 to 6, wherein the plurality of generally planar faces have curvilinear perimeters.
8. The implant assembly of claim 7, wherein the plurality of generally planar faces have circular perimeters.
9. The implant assembly of any one of claims 4 to 6, wherein the plurality of generally planar faces have rectilinear perimeters.
10. The implant assembly of claim 9, wherein the plurality of generally planar faces have polygonal perimeters.
11. The implant assembly of claim 10, wherein the plurality of generally planar faces have triangular perimeters.
12. The implant assembly of claim 1, wherein the textured outer surface includes a plurality of surface elements with polygonal perimeters.
13. The implant assembly of claim 12, wherein the plurality of surface elements are planar within the polygonal perimeters.
14. The implant assembly of claim 12, wherein the plurality of surface elements are convex or concave within the polygonal perimeters.

15. The implant assembly of claim 1, wherein the textured outer surface includes a three-dimensional tessellation incorporating polygonal surfaces.
16. The implant assembly of claim 1, wherein the first quasi-spherical member approximates a honeycomb of polyhedral cells.
17. The implant assembly of claim 1, wherein the textured outer surface includes a plurality of outermost extensions spaced from one another on the textured outer surface and defining a first radius of the quasi-spherical member and a plurality of innermost depressions spaced from one another on the textured outer surface and defining a second radius of the first quasi-spherical member.
18. The implant assembly of claim 17, wherein the bore of the head member includes a tapered segment with a first diameter that is twice the first radius and a second diameter that is twice the second radius.
19. The implant assembly of claim 17 or 18, wherein said plurality of innermost depressions occur on planar surfaces on the first quasi-spherical member.
20. The implant assembly of claim 17 or 18, wherein said plurality of innermost depressions occur on concave surfaces on the first quasi-spherical member.
21. The implant assembly of any one of claims 17 to 20, wherein said plurality of outermost extensions are symmetrical peaks on the first quasi-spherical member.

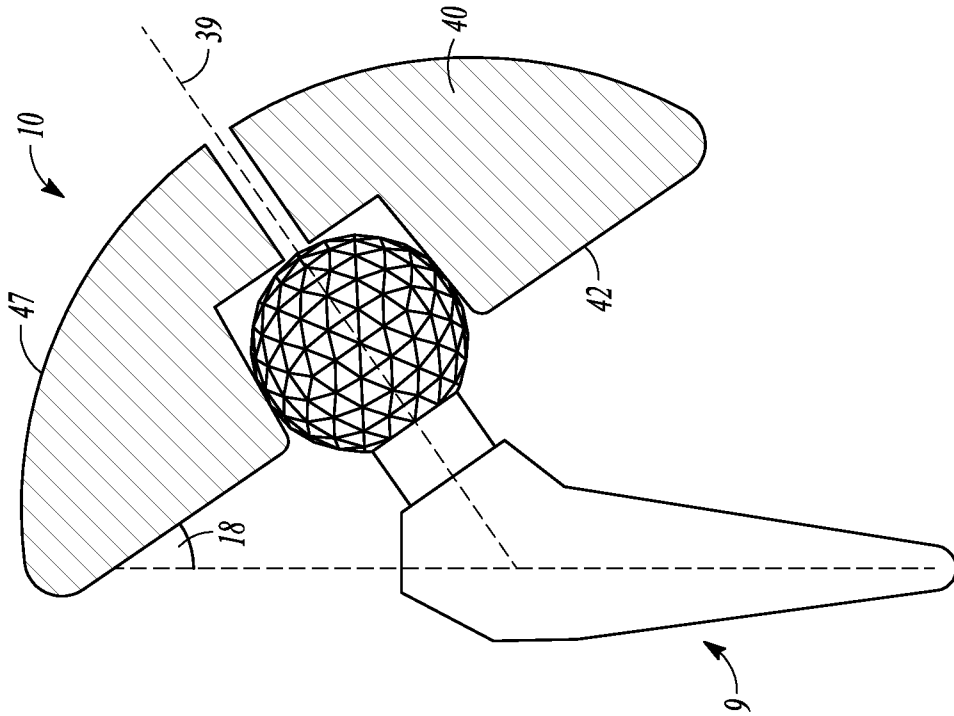

FIG. 1B

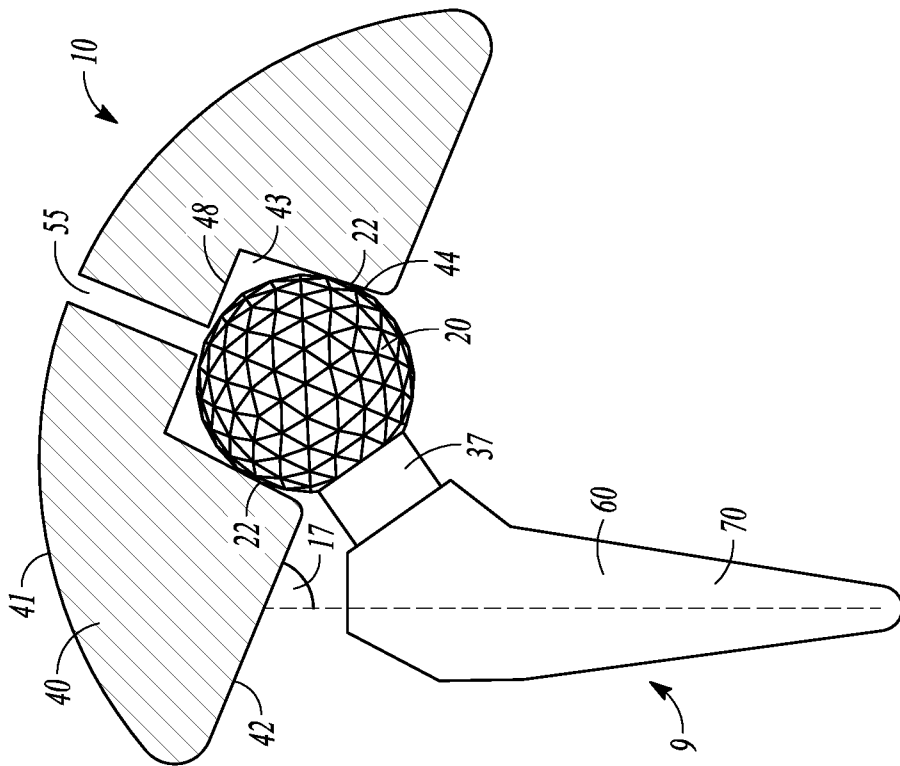

FIG. 1A

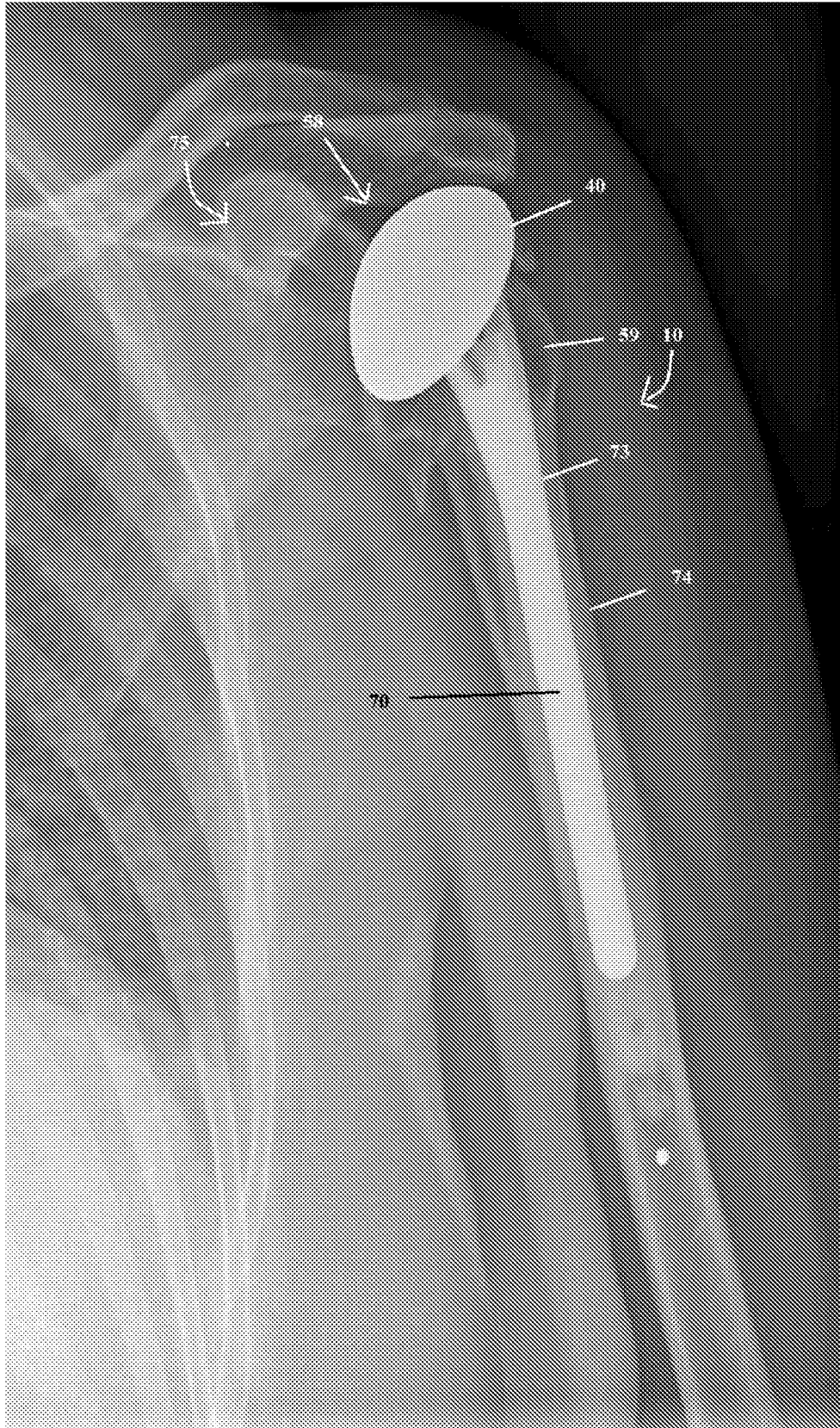

FIG. 1C

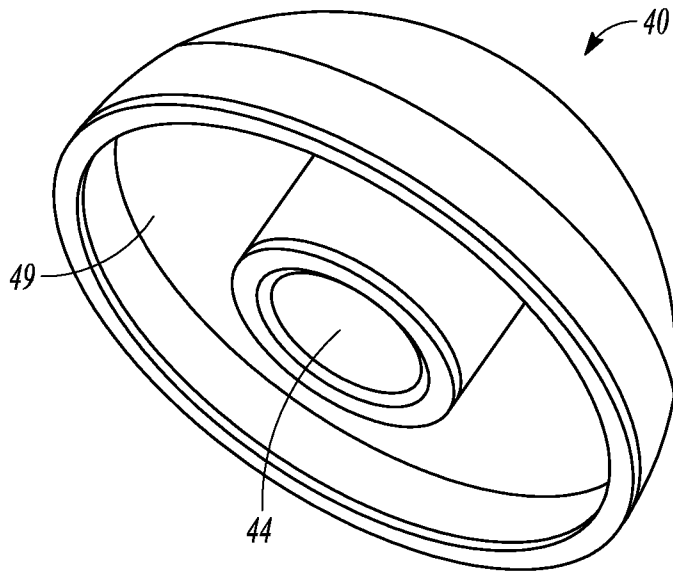

FIG. 2

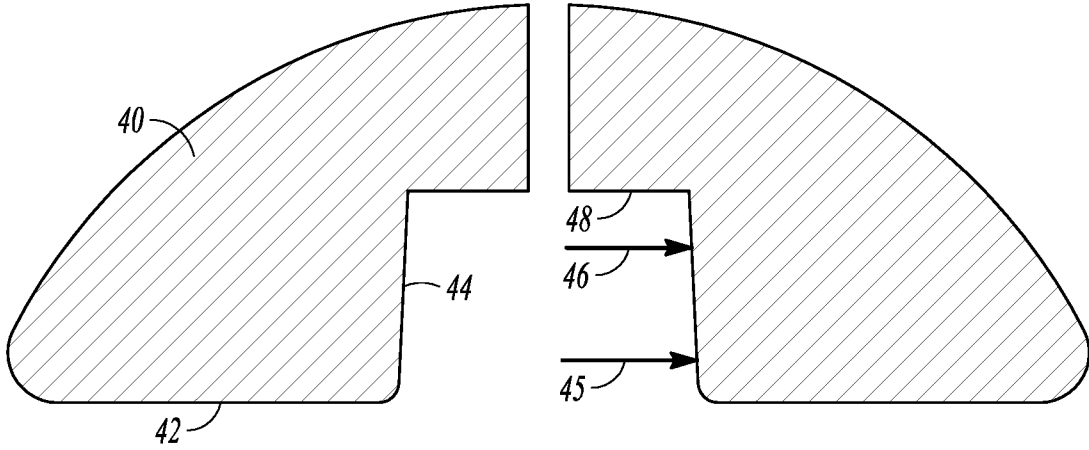

FIG. 3A

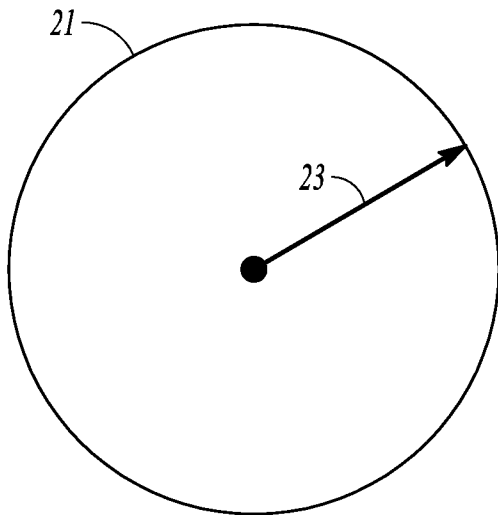

FIG. 3B

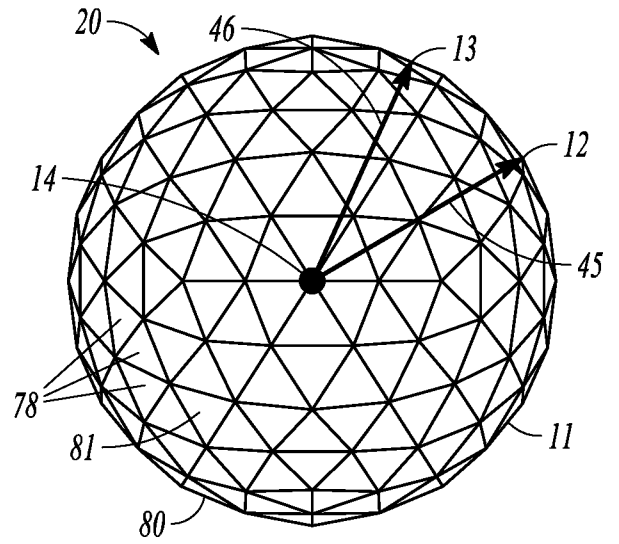

FIG. 3C

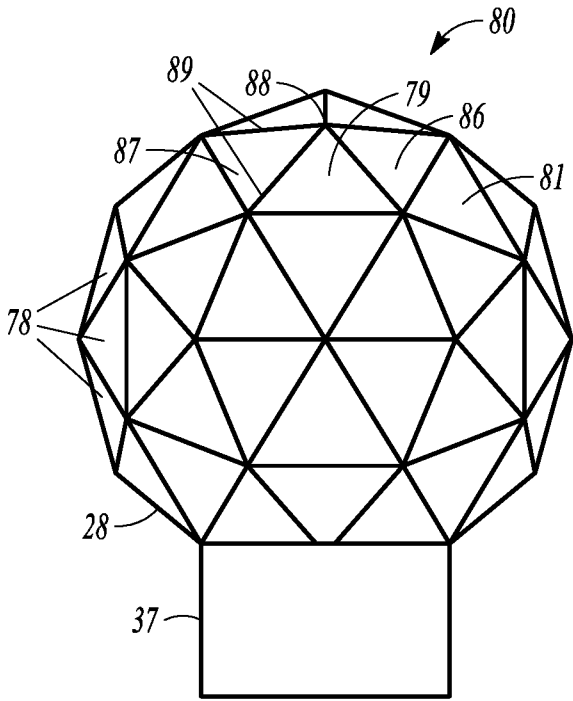

FIG. 4A

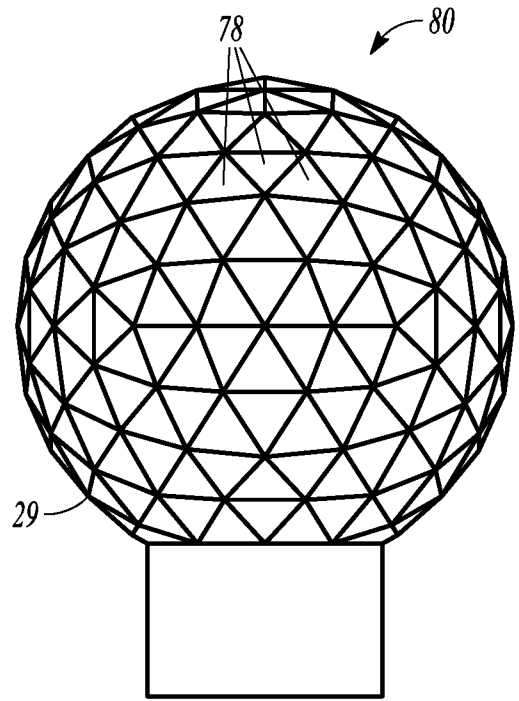

FIG. 4B

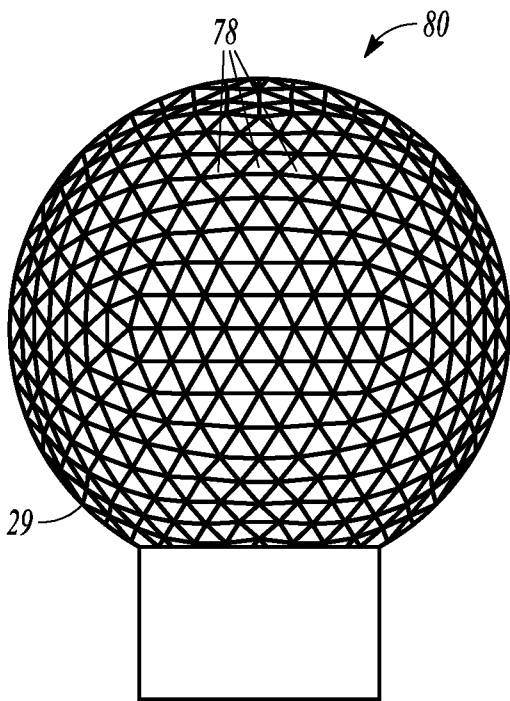

FIG. 4C

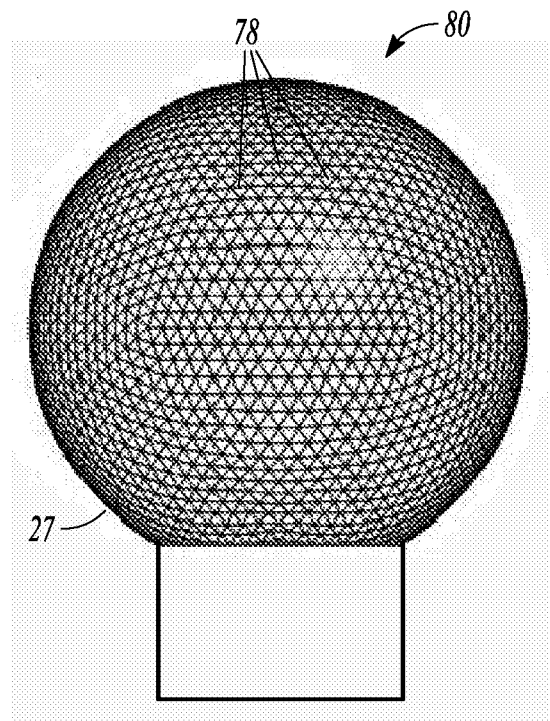

FIG. 4D

6/25

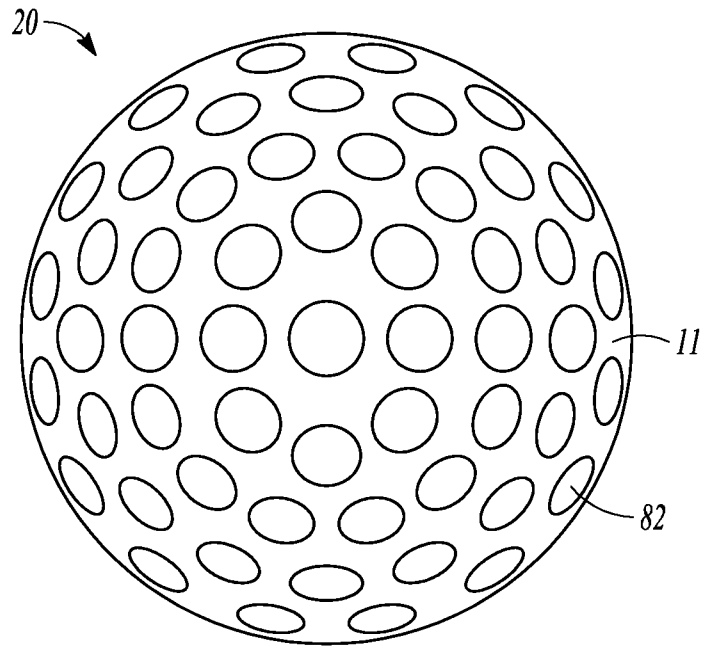

FIG. 5A

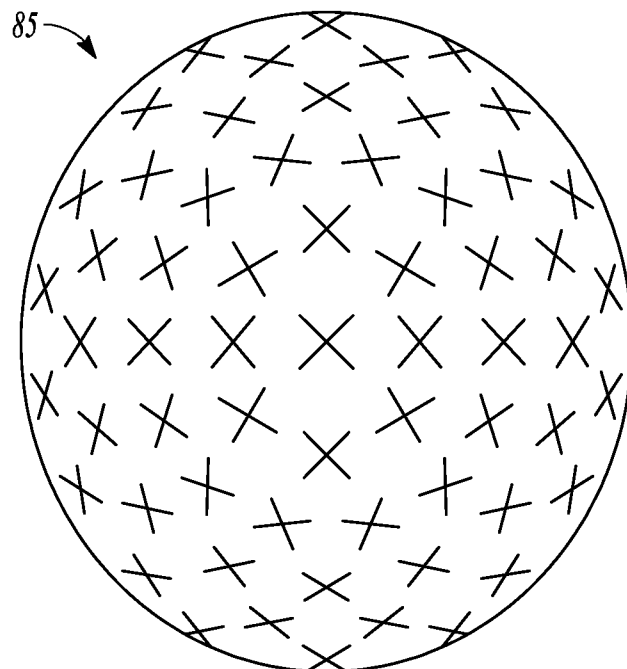

FIG. 5B

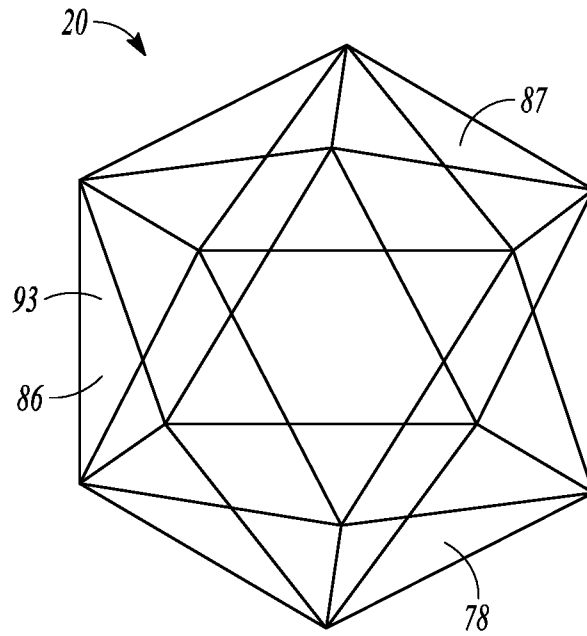

FIG. 6A

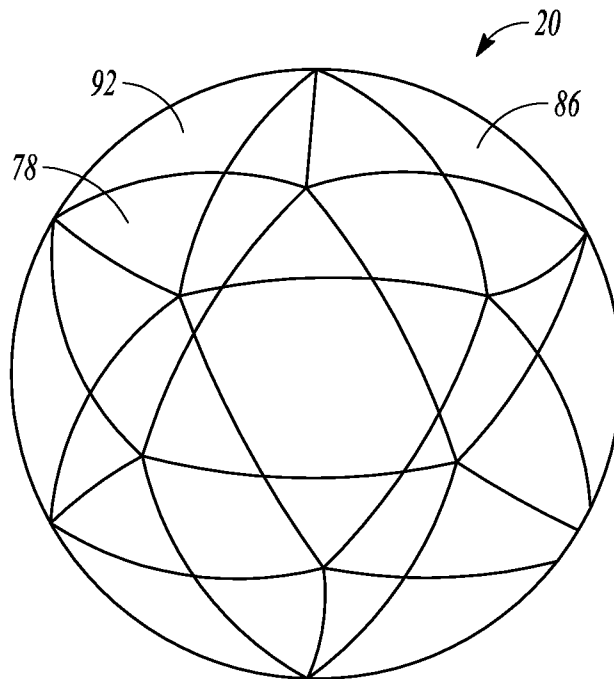

FIG. 6B

8/25

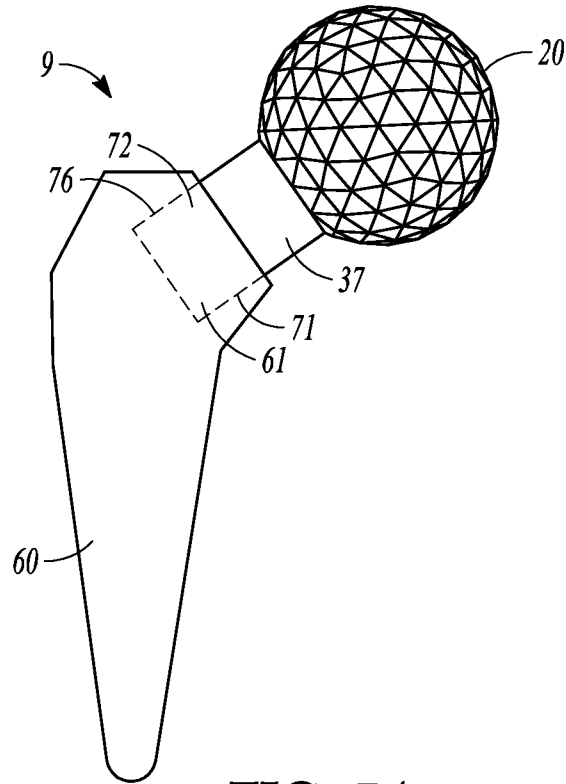

FIG. 7A

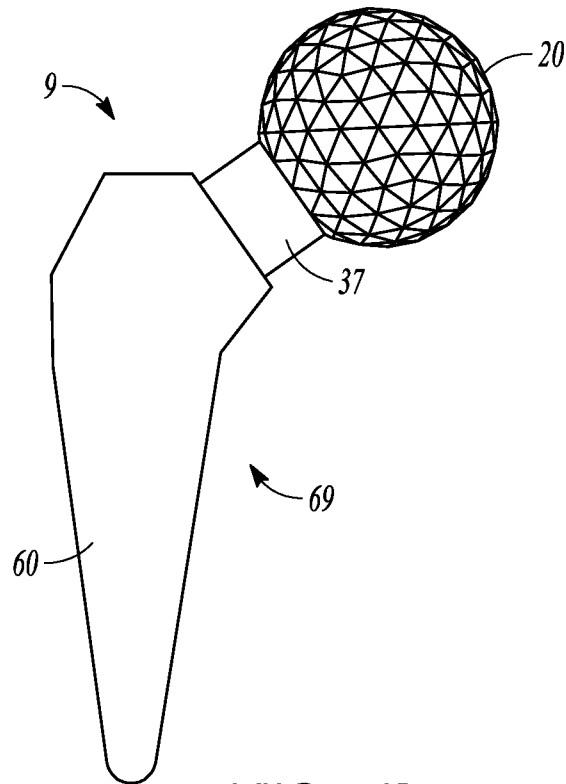

FIG. 7B

9/25

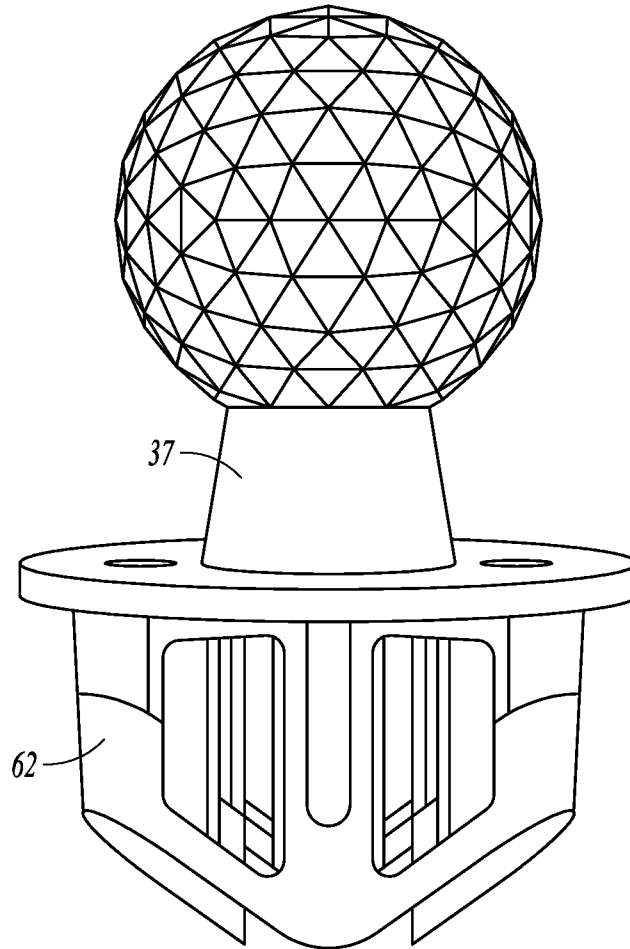

FIG. 8

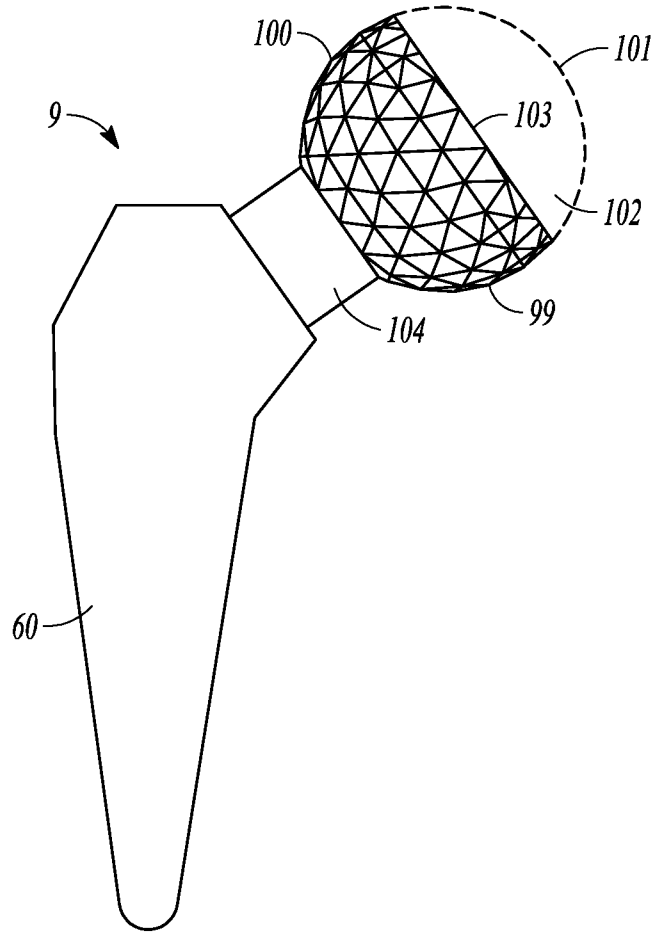

FIG. 9

11/25

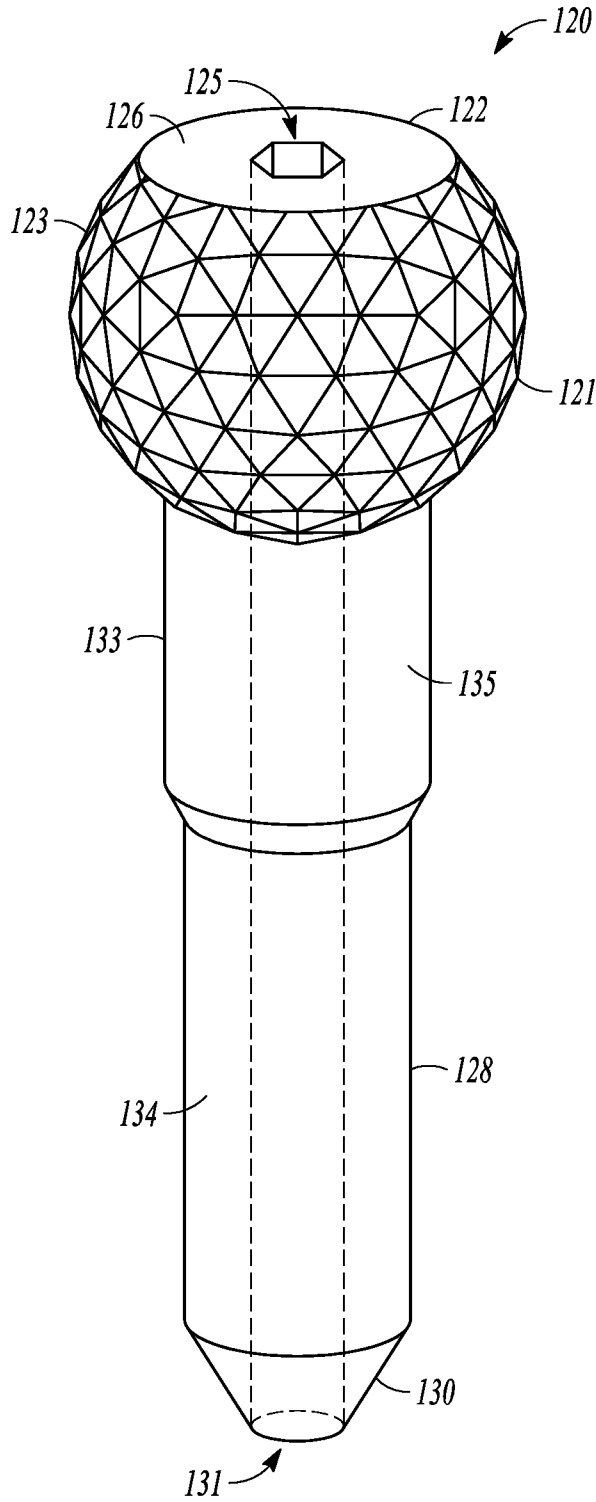

FIG. 10

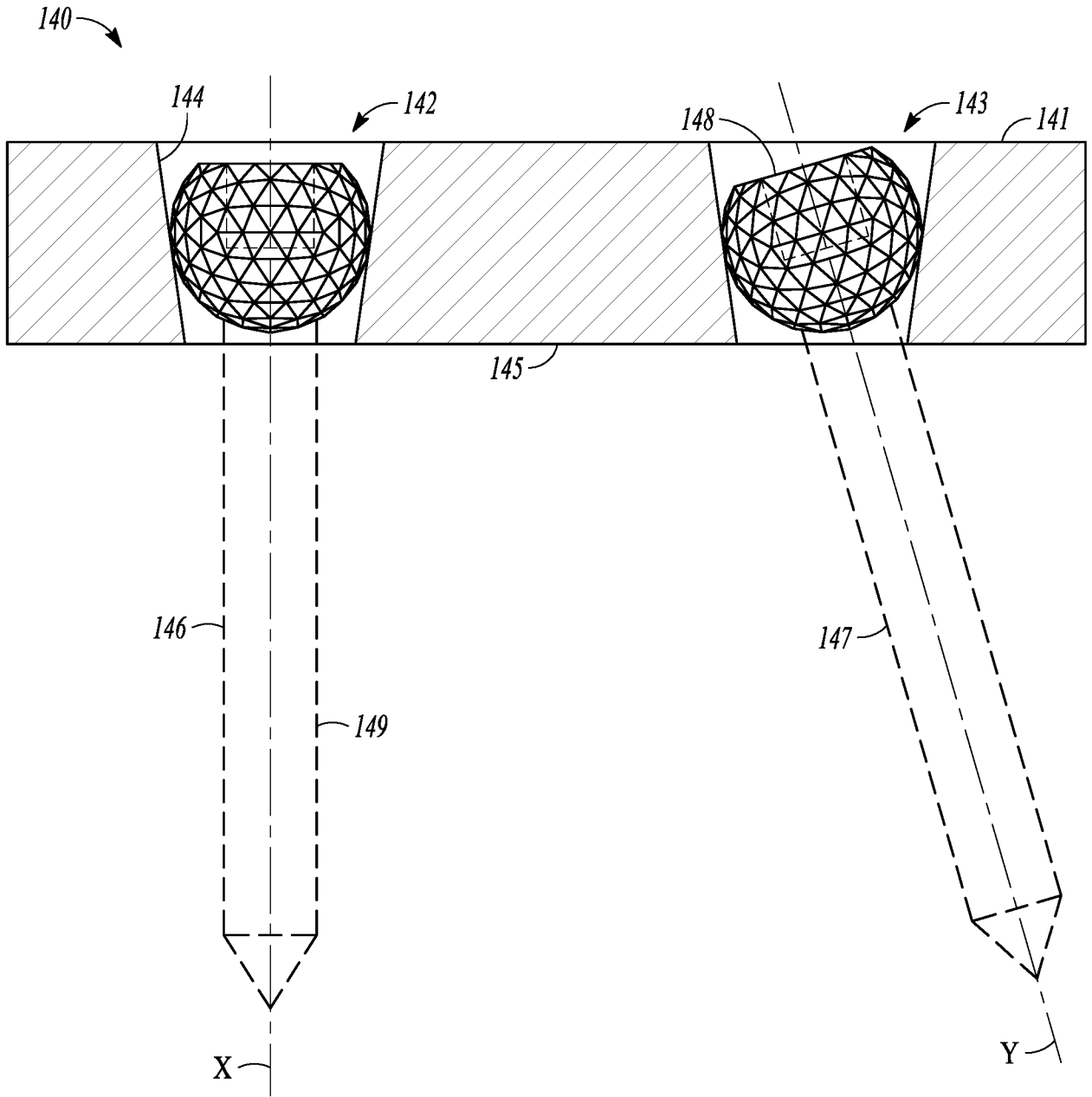

FIG. 11

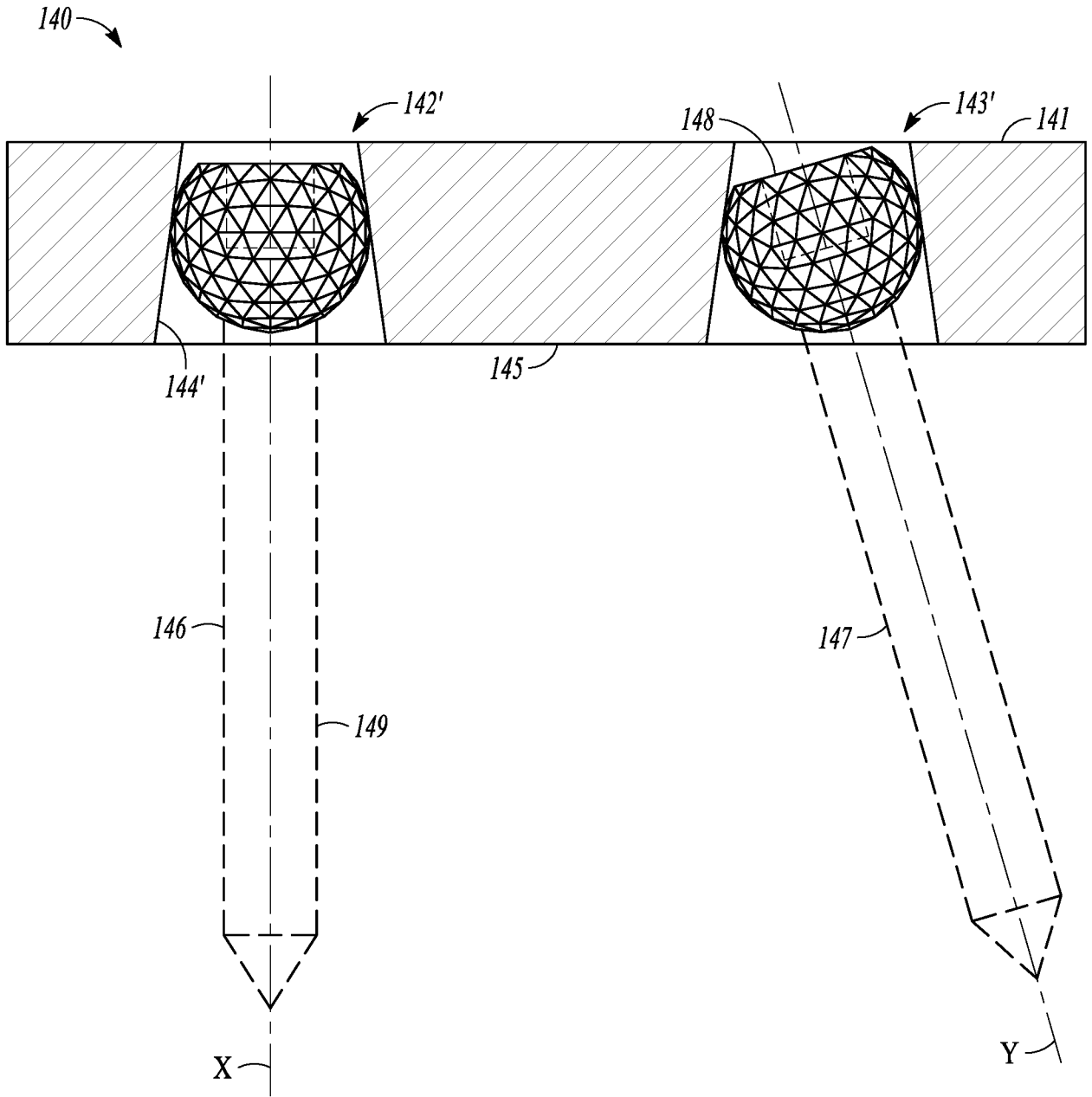

FIG. 12

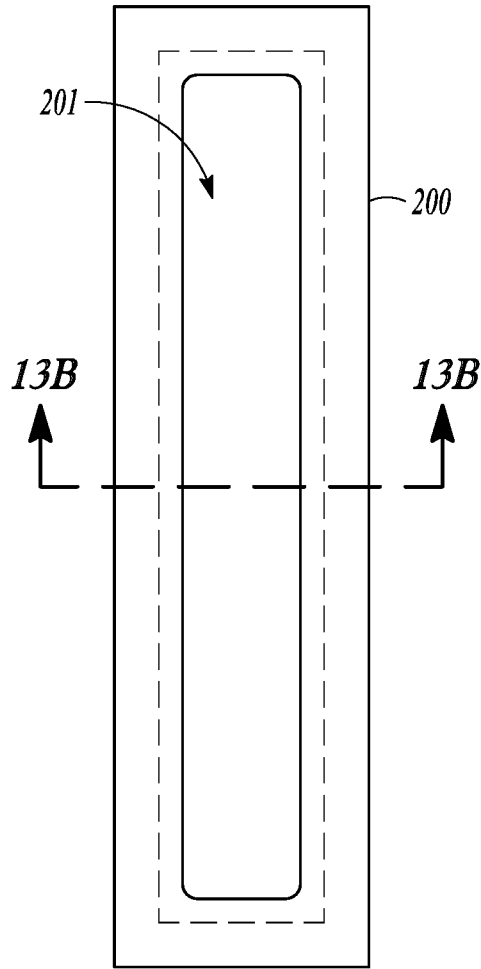

FIG. 13A

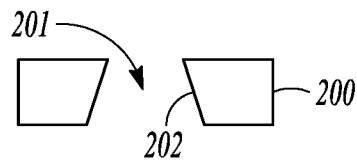

FIG. 13B

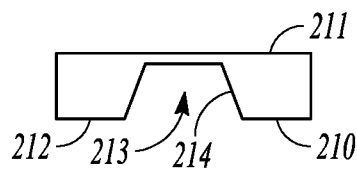

FIG. 13C

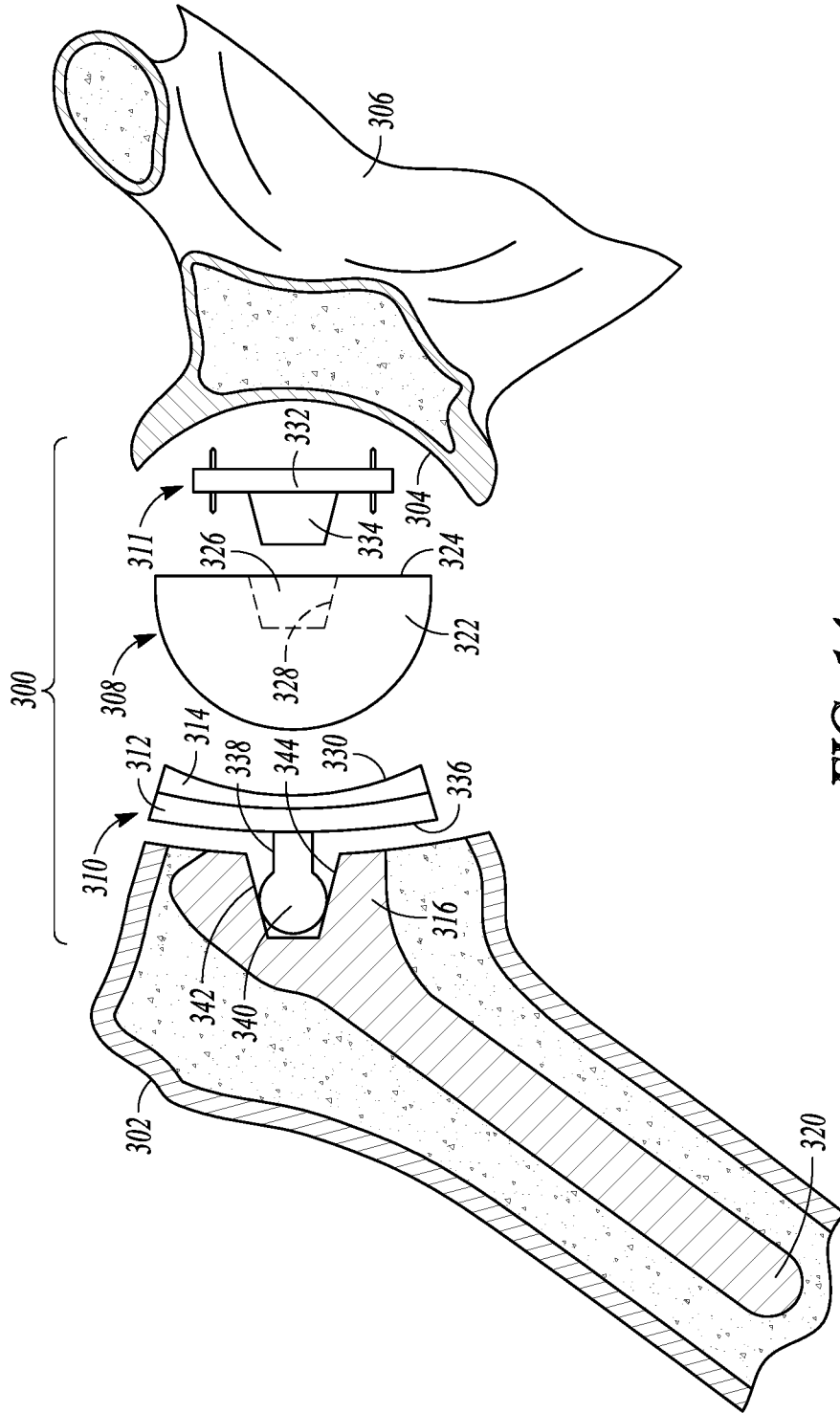

FIG. 14

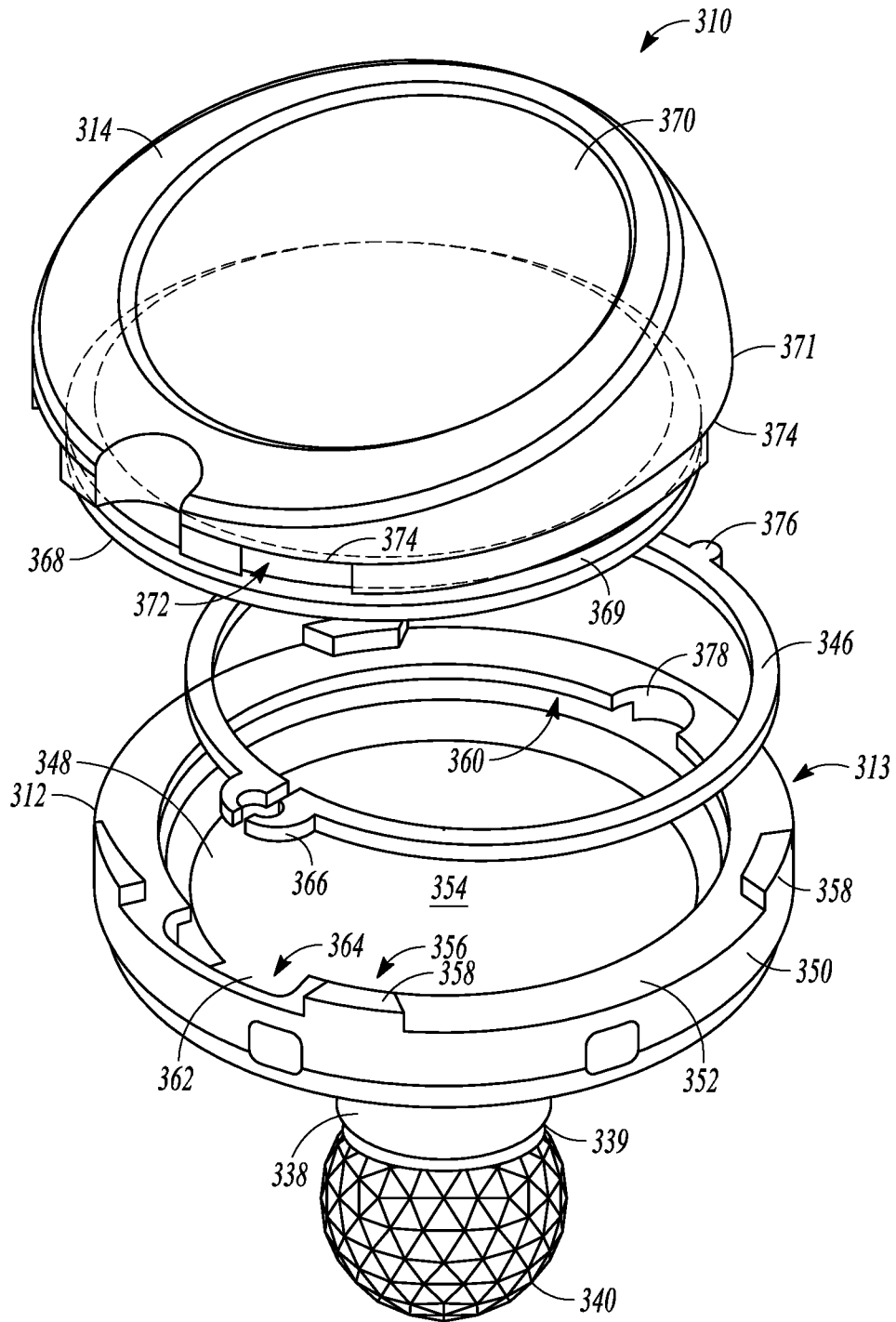

FIG. 15

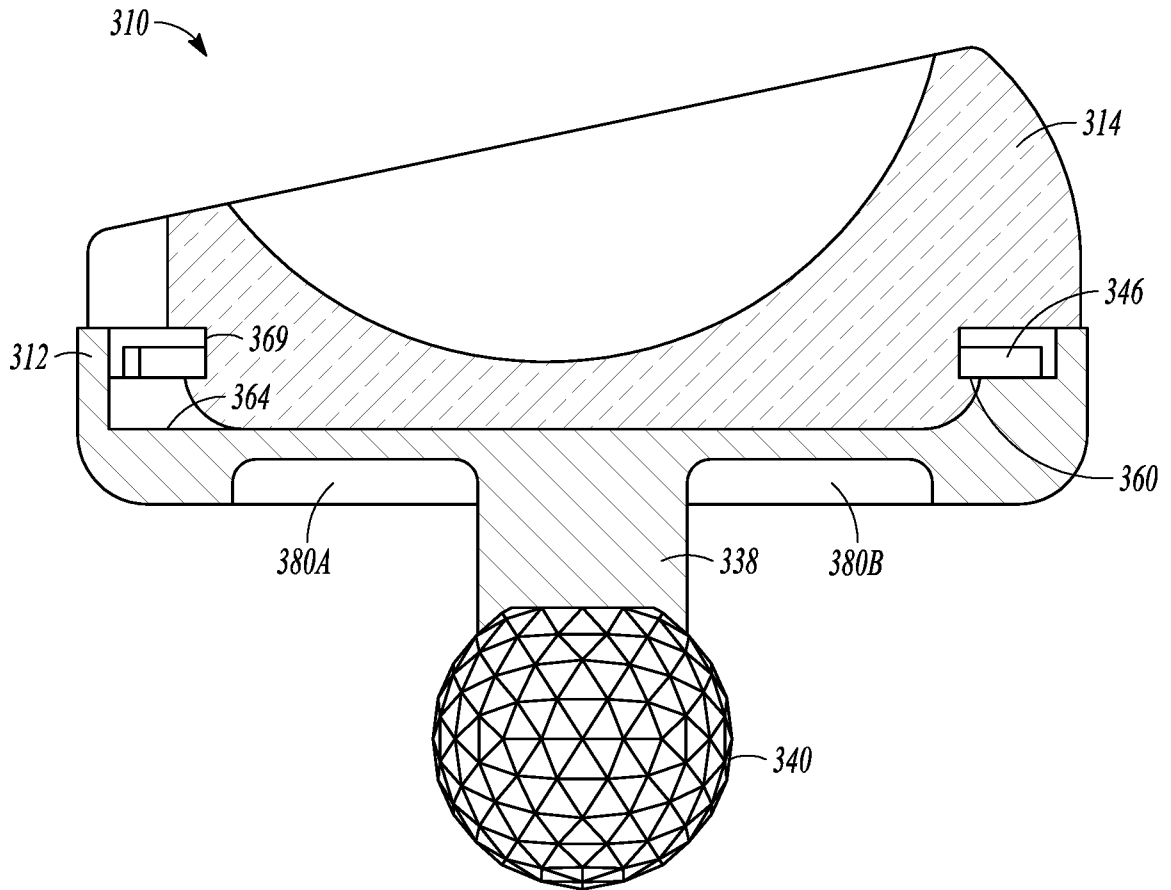

FIG. 16

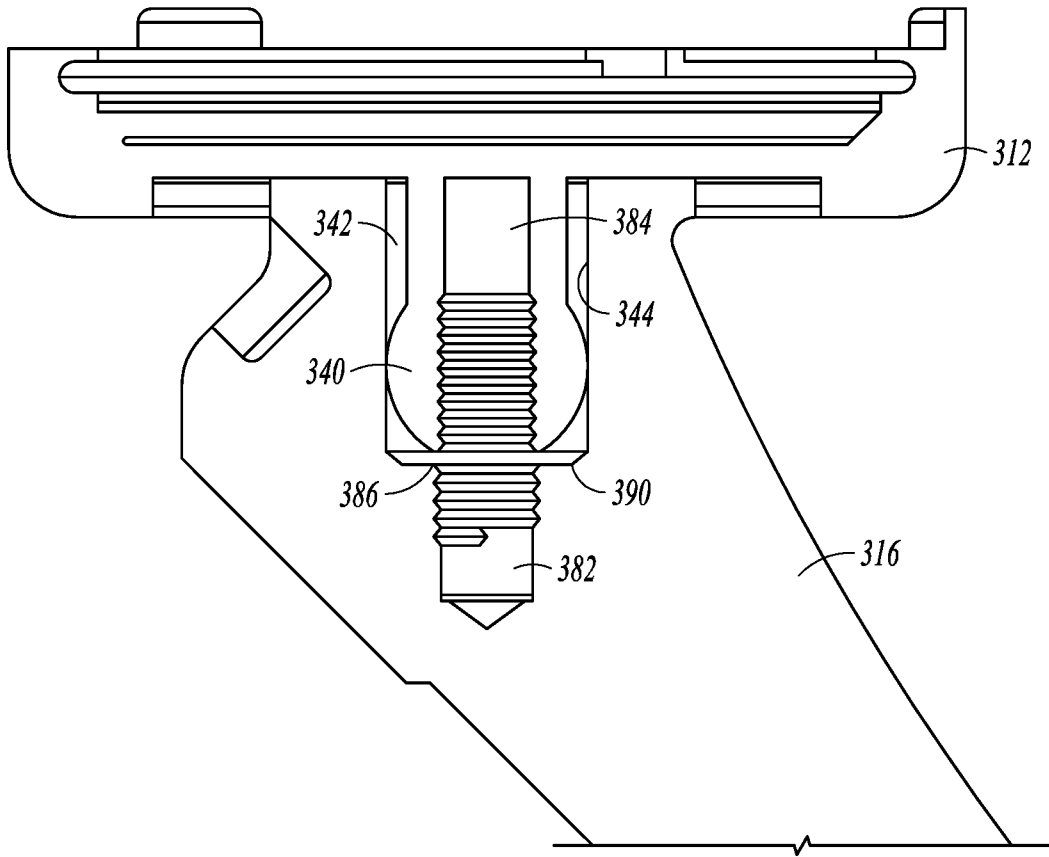

FIG. 17

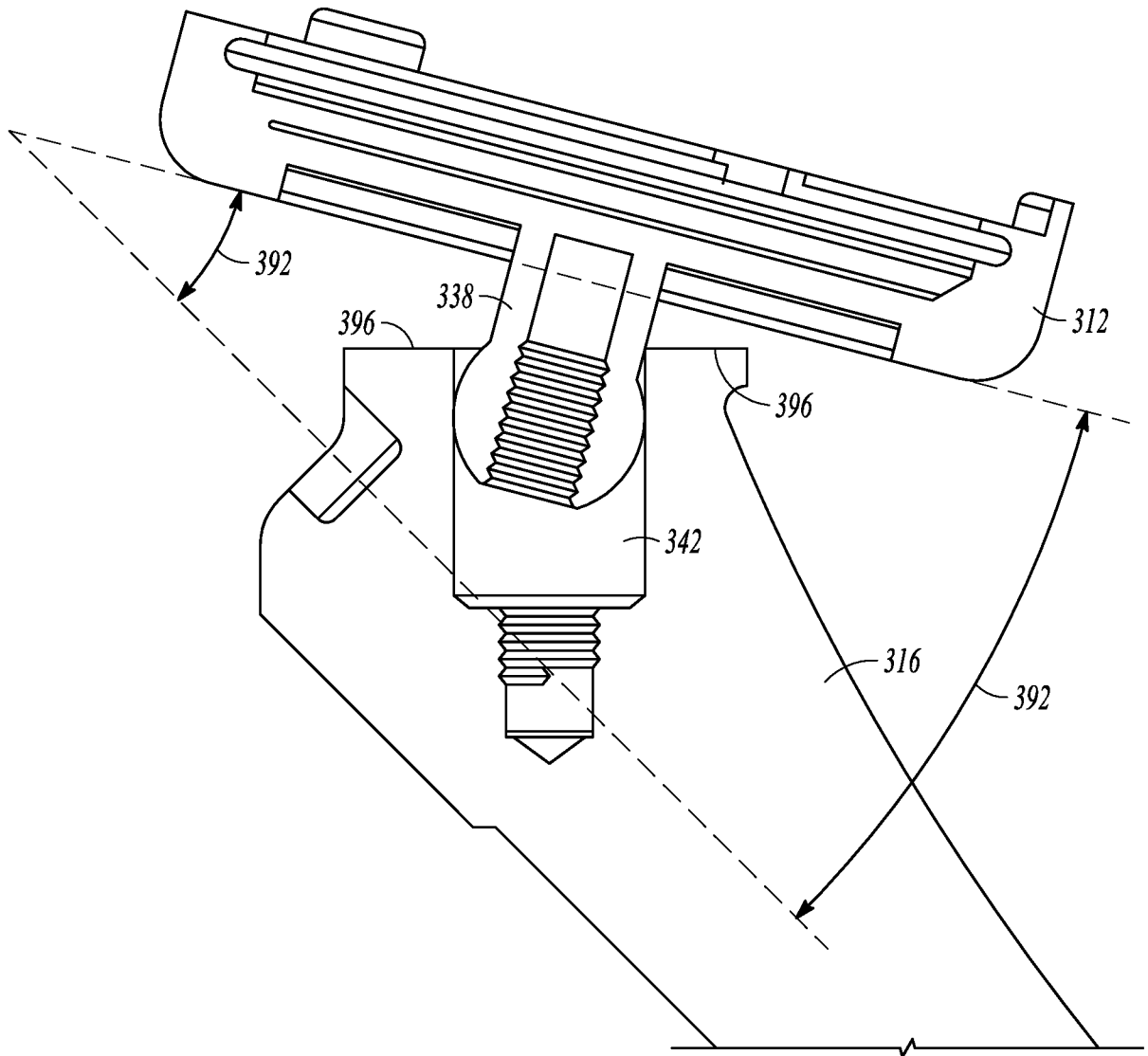

FIG. 18

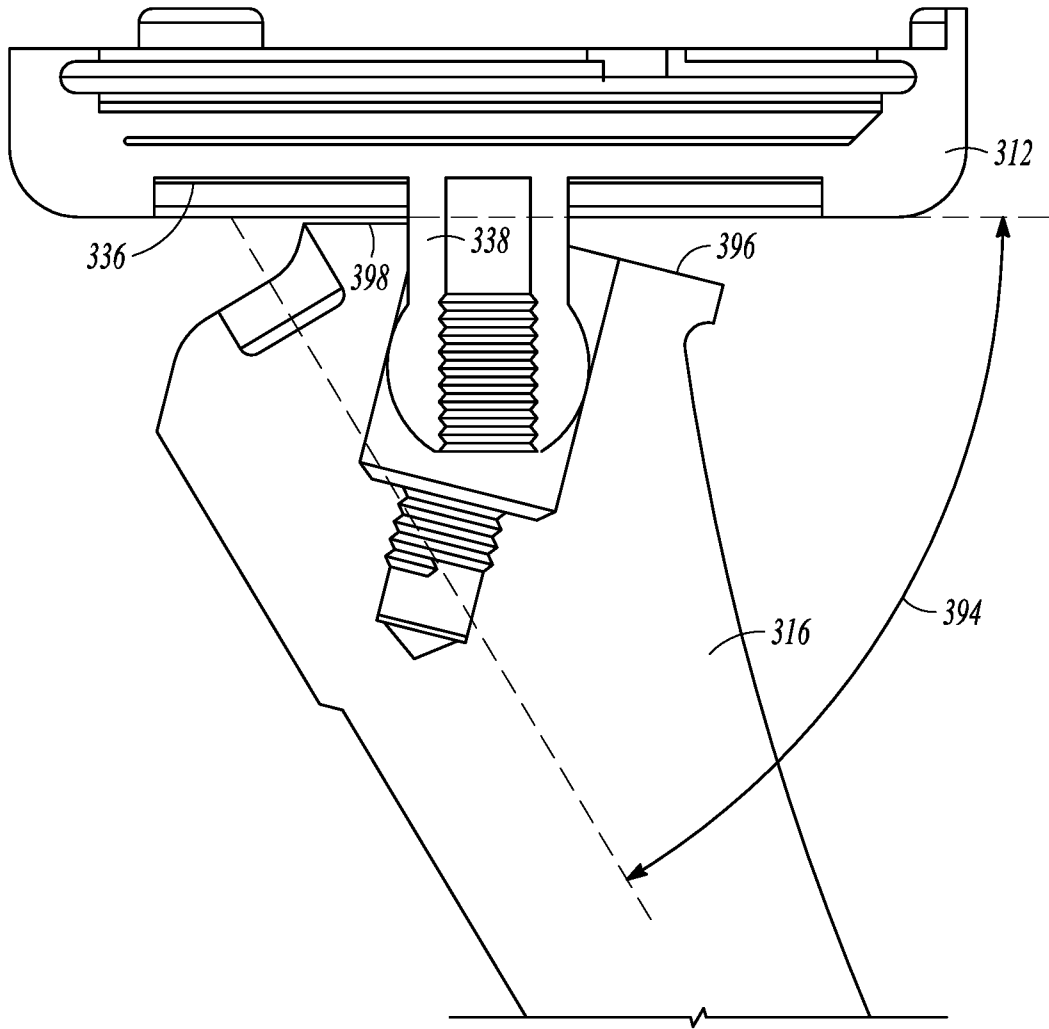

FIG. 19

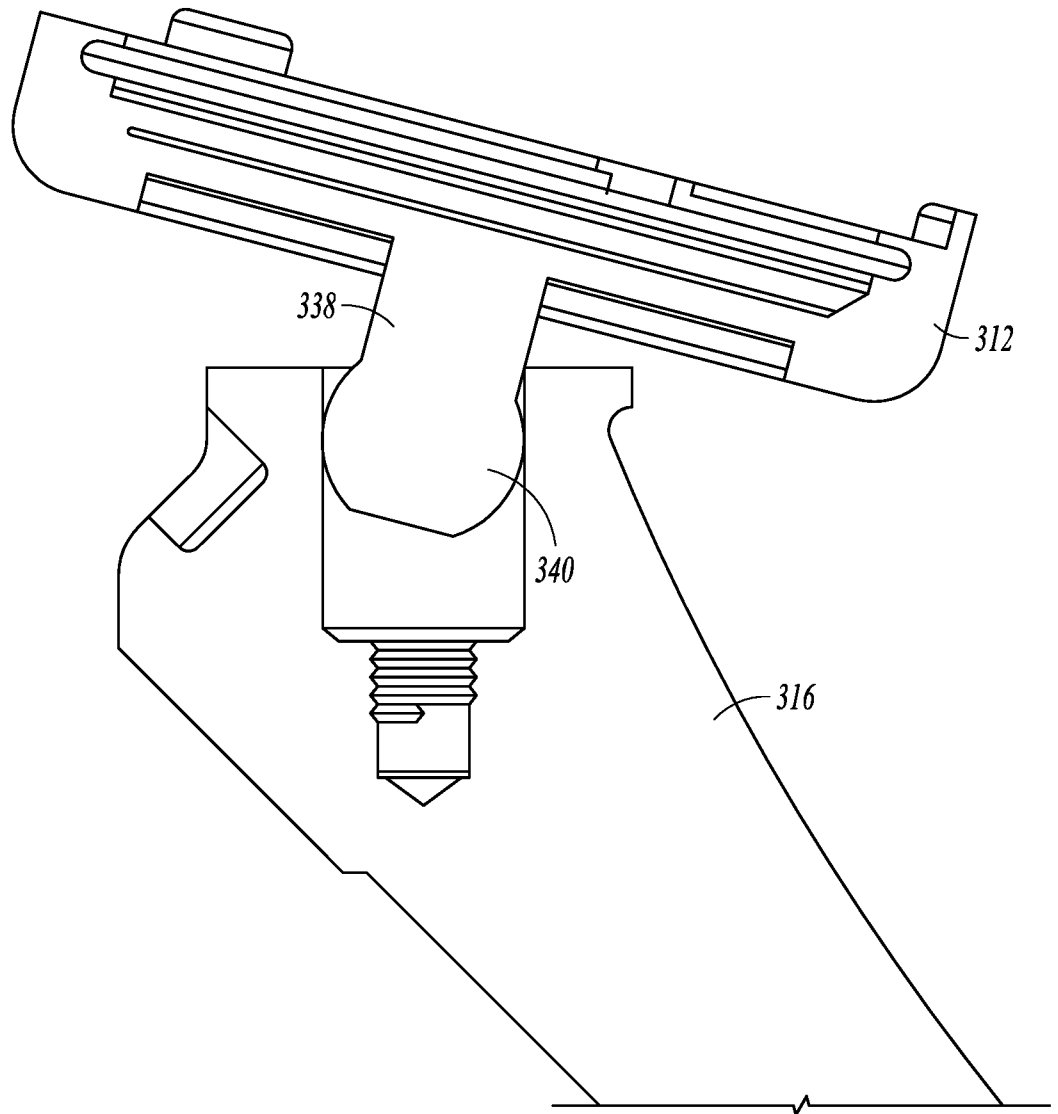

FIG. 20

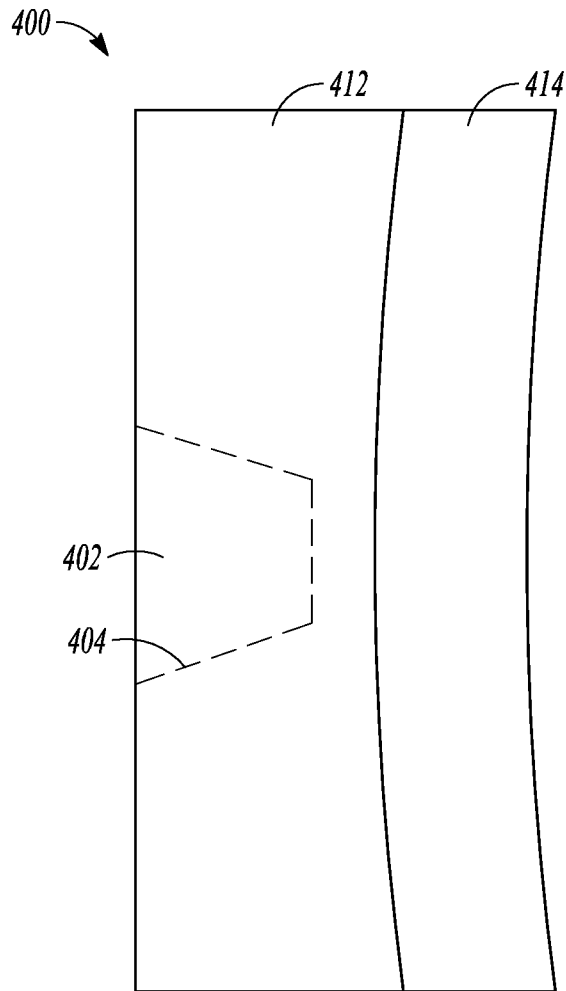
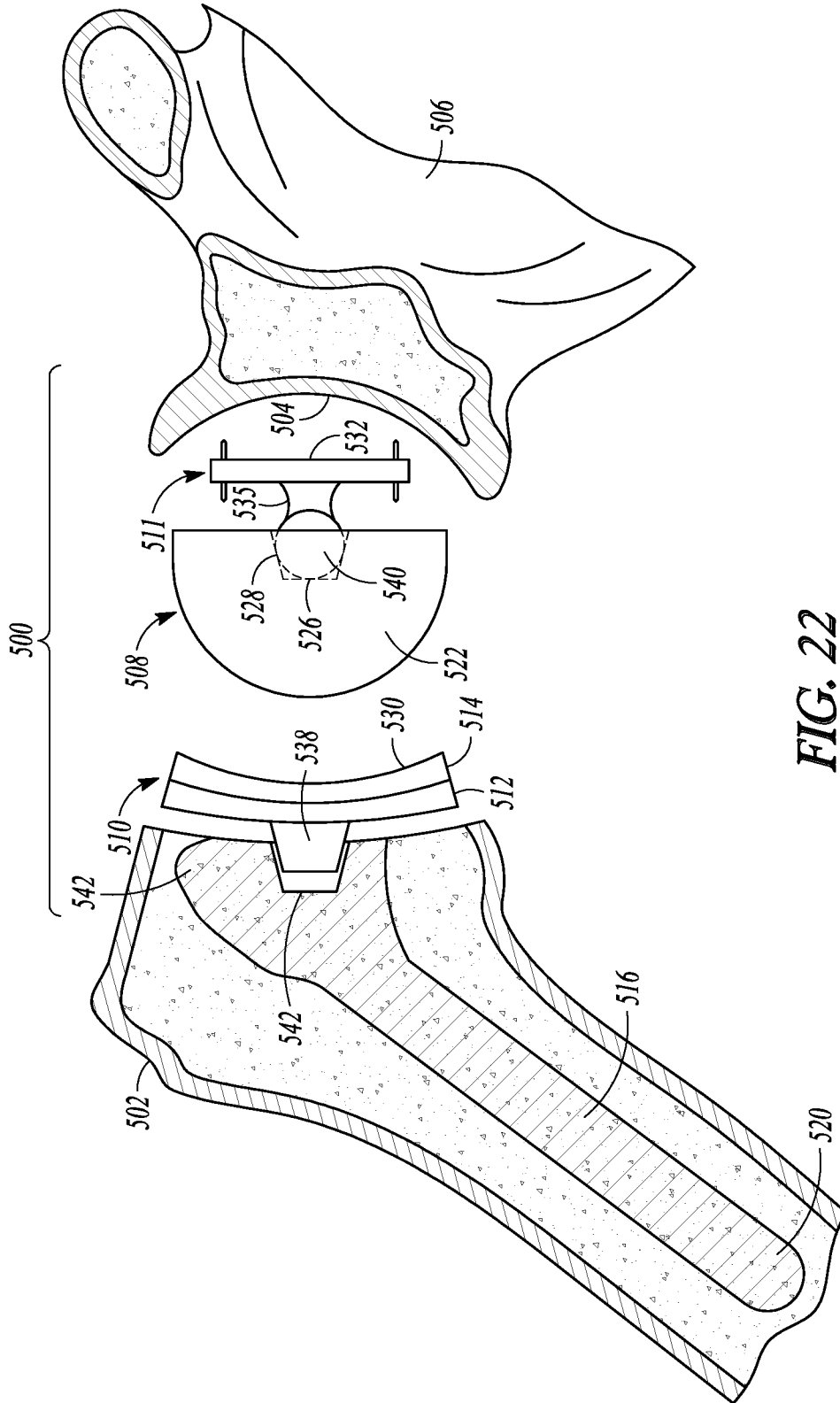

FIG. 21



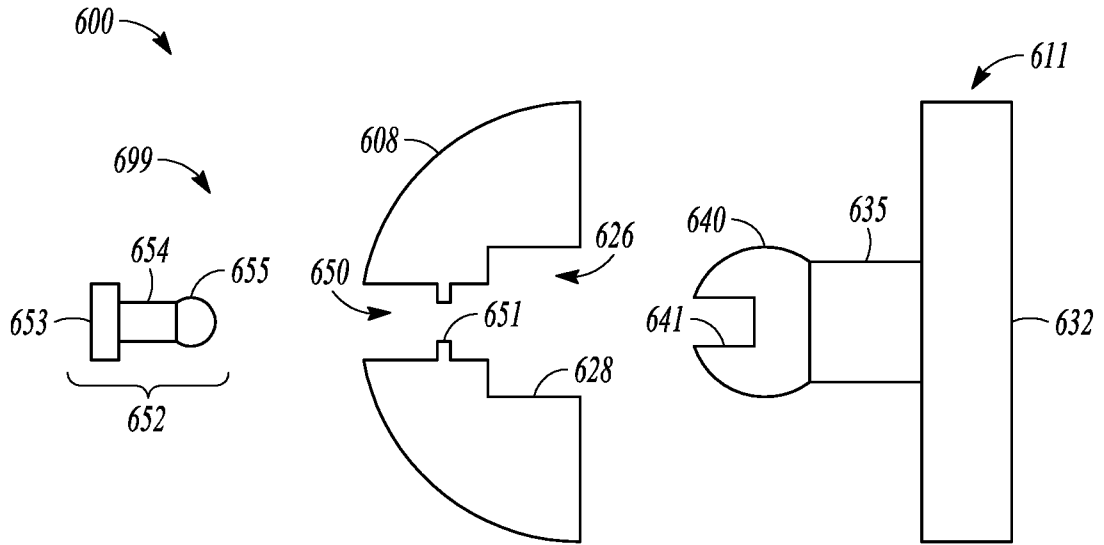

FIG. 23

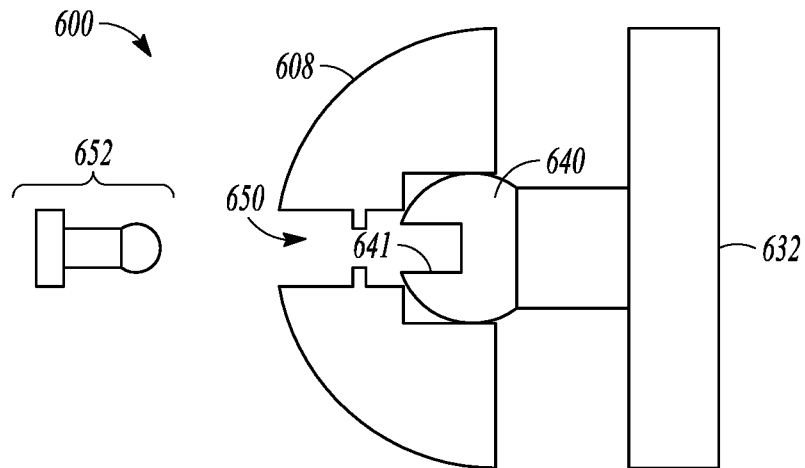

FIG. 24

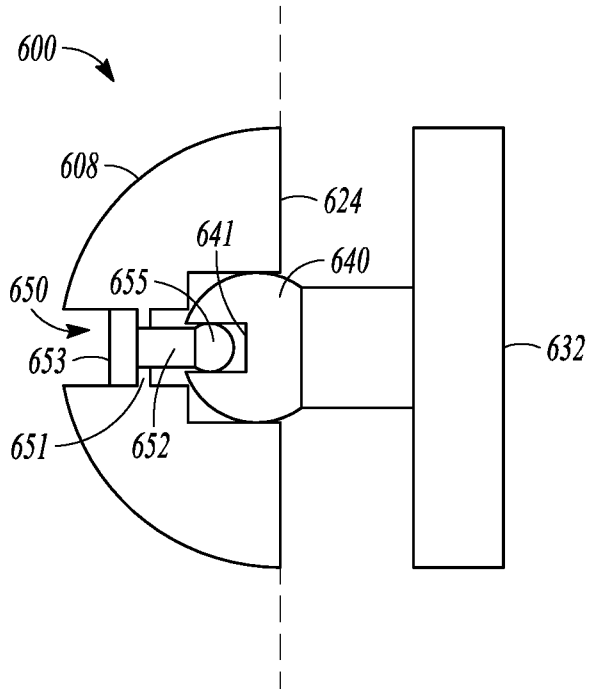

FIG. 25

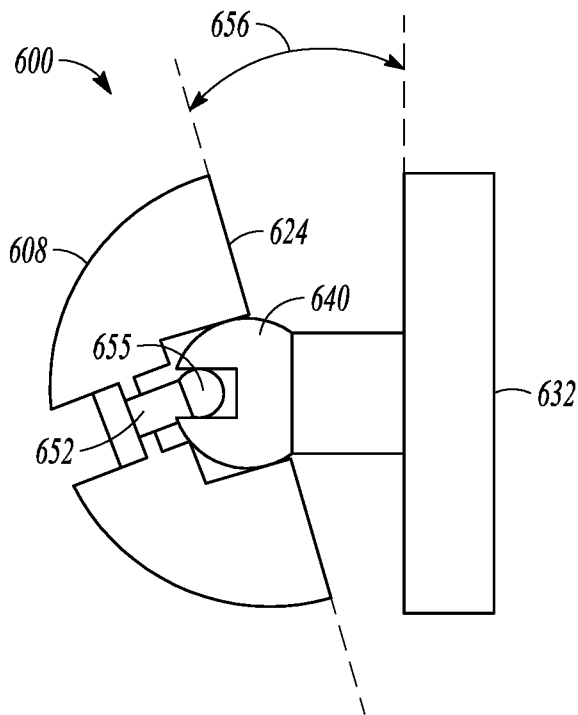

FIG. 26

