

(No Model.)

C. HEMJE.
LAMP HEATER.

No. 522,662.

Patented July 10, 1894.

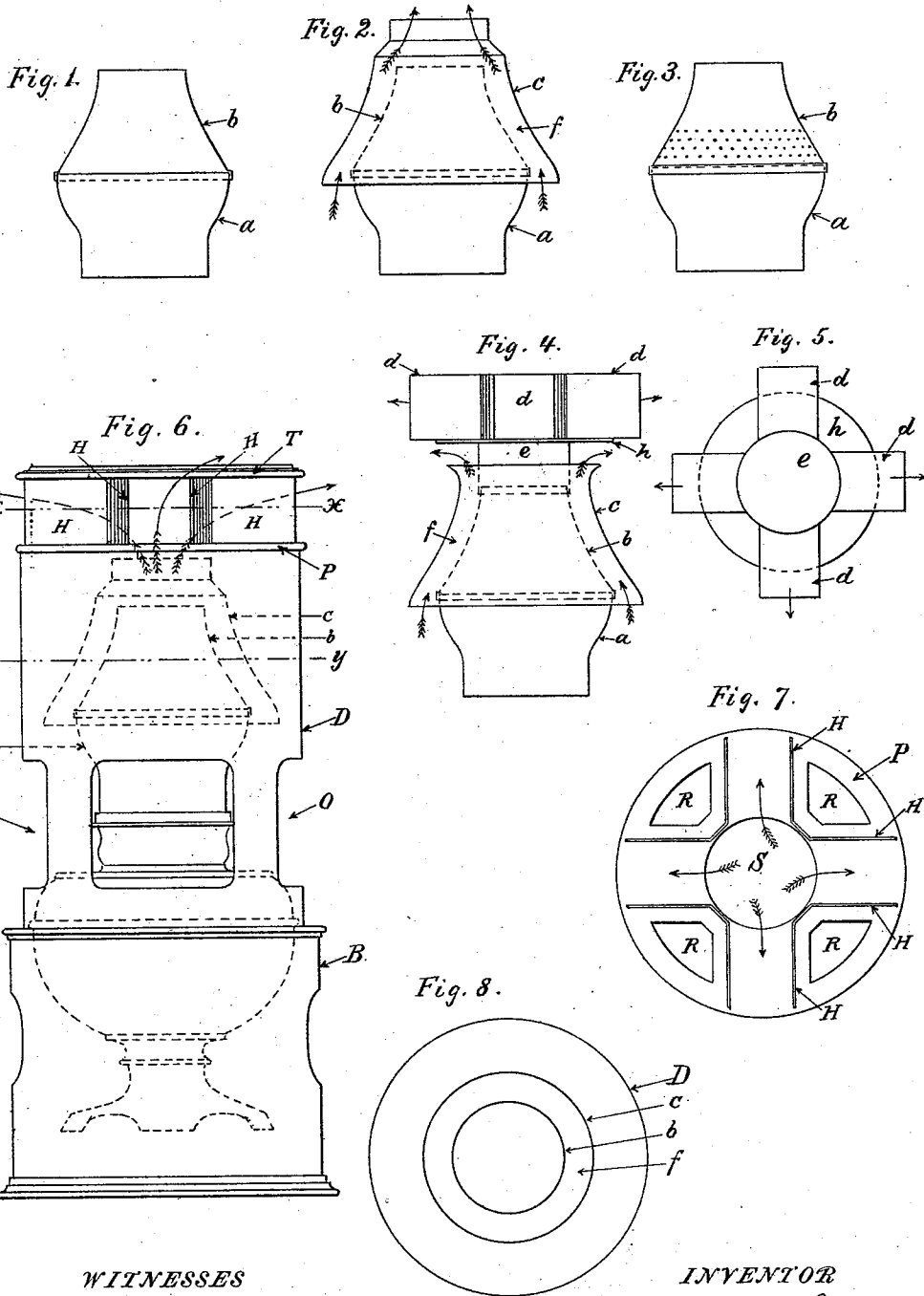

WITNESSES
John Geofhan
A. Mc Donnis

INVENTOR
Charles Hemje.

UNITED STATES PATENT OFFICE.

CHARLES HEMJE, OF ANNAPOLIS, MARYLAND.

LAMP-HEATER.

SPECIFICATION forming part of Letters Patent No. 522,662, dated July 10, 1894.

Application filed March 17, 1894. Serial No. 504,062. (No model.)

To all whom it may concern:

Be it known that I, CHARLES HEMJE, a citizen of the United States, residing at Annapolis, in the county of Anne Arundel and State of Maryland, have invented certain new and useful Improvements in Lamp-Heaters; and I do hereby declare the following to be a full, clear, and exact description of the invention, such as will enable others skilled in the art to which it appertains to make and use the same.

My invention relates to improvements in lamp heaters, the object being to create an increased draft, a better combustion and a more rapid circulation of air through certain parts of the lamp, which air, after having been heated, is discharged and utilized for heating purposes.

The invention consists in the construction of certain details and arrangement of parts as will be more fully described hereinafter and specifically pointed out in the claims, reference being had to the accompanying drawings and the letters of reference marked thereon.

Like letters indicate similar parts in the different figures of the drawings, in which—

Figure 1 represents a vertical section through my improved chimney. Fig. 2 is a view of the chimney with an outer chimney or jacket surrounding its upper part. Fig. 3 is a modification of Fig. 1. Fig. 4 is a view of the chimney with a cap on its upper end, having radiating discharge pipes and an outer chimney or jacket surrounding the upper part of the inner chimney. Fig. 5 is a plan view of the chimney cap. Fig. 6 is a view of my improved lamp heater, showing parts covered by the drum, in dotted lines. Fig. 7 is a section on the line $x-x$ of Fig. 6, and Fig. 8 is a section on the line $y-y$ of Fig. 6.

The principal object of my improvement is to increase the circulation of air through the lamp, to heat the air by letting it pass over the heated surface of the chimney, and then, instead of letting this heated air, as well as the products of combustion take a direct upward course, distribute them in a lateral direction and as low down as possible.

For these reasons, the chimney which forms a part of my invention, is of a special construction and as shown in Fig. 1, is made much shorter than the ordinary chimney. Unlike

the chimney now in use, which has a very gradual taper above its largest part or belly, my improved chimney changes its form very suddenly at a height a little above the top of the flame, at which point the lower part a and the upper part b form an obtuse angle, the upper part b forming a partial roof over the flame. On account of being so near the flame, the upper part b of the chimney will become much more heated than the corresponding part in the ordinary chimney, for which reason the air above it will become hotter and ascend more quickly. To withstand this intense heat, the chimney is preferably made in two parts, the upper part b being made of metal, while the lower part a is made of glass to preserve the illuminating effect, so that the lamp on which it is used, may serve the double purpose of heating and illuminating.

While the metal part may be permanently attached to the glass part, it is more convenient to have it detachable, simply surrounding the upper rim of the glass with a vertical flange as shown in Fig. 1.

Fig. 2 shows the chimney with an outer chimney or jacket c surrounding the upper part b , leaving an annular space f between them. The small quantity of air in the annular space f will be heated to a high degree by the surface of the inner chimney b and will therefore ascend quickly and escape through the opening in the top, thus causing a constant inflow of cold air at the bottom, as indicated by the arrows.

Fig. 3 shows the chimney with the upper part b perforated, allowing some of the heat from within to escape through the perforations for the purpose of increasing the draft on the outside. The perforated chimney b is most effective when used in connection with the outer chimney or jacket c , the heat escaping through the perforations entering the annular space f , thereby increasing the circulation of air through the same.

To prevent the products of combustion and heated air passing through the chimney to pass directly upward, the upper end of the chimney may be fitted with a removable cap e , provided with laterally extending discharge tubes d , through which the heat is distributed in a lateral direction, while the heated air formed between the chimney and the jacket

c is permitted to escape upward or may be deflected from its direct upward course by a check plate *h* attached to the under side of the radiating tubes *d* as shown in Figs. 4 and 5.

5 Fig. 6 shows my improved lamp heater in stove form, the parts inside of the drum, which have already been explained and shown in the preceding figures being shown in dotted lines. The lamp or fount is shown supported in a suitable base *B* and is provided with the already described chimney and jacket surrounding the latter. The upper part of the lamp and chimney are inclosed by a drum *D*, standing on the base *B* or being otherwise suitably supported. In case the drum stands directly on the base, it has to be provided in its lower part with sufficiently large openings *O* to admit the necessary air to supply the flame as well as for circulation through and around the chimneys.

10 To the upper edge of the drum *D* is attached a top-plate *P* as shown in Fig. 6, provided with a central opening *S* through which the products of combustion and the heated air passing between the inner and outer chimneys pass, as well as with a plurality of openings *R* near its periphery, through which the heated air formed between the chimney and the drum can escape, as shown in Fig. 7.

15 A short distance above the top *P*, and supported by ribs *H* is a closed top *T*, which may be provided with a removable lid, the ribs *H* being arranged to form channels through which the products of combustion and heated air are discharged in a lateral direction as shown in Figs. 6 and 7.

The stove may be used for heating and cooking simultaneously.

20 If the drum *D* is removed and the lamp taken from the stand *B*, it can be used, without making any changes, as a table lamp for illumination, and if illumination and heating are desired at the same time, it can be accomplished by placing a special cap, such as has already been described and shown in Figs. 4 and 5, on the top of the chimney.

25 Having thus fully described my invention, what I claim as new, and desire to secure by Letters Patent, is—

30 1. The herein described chimney for lamps, consisting of an imperforate lower part and an upper part shaped like, or nearly like the frustum of a cone, said upper part being

provided with one or more rows of perforations, in combination with an outer chimney or jacket surrounding the perforated part of the chimney, constructed so as to form an annular space into which a portion of the products of combustion are discharged, for the purpose of increasing the circulation of air through said annular space, substantially as described.

2. The herein described drum for lamp or gas stoves, being open at both ends and having side openings near its lower edge for the admission of air, in combination with a grate consisting of deep vertical ribs resting on the upper and open end of the drum, and forming a central opening and lateral channels, and a deflecting plate resting on or secured to the grate and with a chimney situated within the drum, substantially as described.

3. The herein described lamp stove, consisting of a lamp having a chimney formed of two parts, the lower part of said chimney being imperforate, while its upper part is provided with one or more rows of perforations, in combination with a drum which is open at both ends and provided with side openings near its lower edge, a grate consisting of deep vertical ribs resting on the upper end of the drum, and forming a central opening and lateral channels, and a deflecting plate resting on or secured to the grate, substantially as described.

4. The herein described lamp stove, consisting of a lamp having a chimney formed of two parts, the lower part of said chimney being imperforate, while its upper part is provided with one or more rows of perforations, in combination with an outer chimney or jacket surrounding the upper or perforated part of the chimney, a drum which is open at both ends and provided with side openings near its lower edge, a grate consisting of deep vertical ribs resting on the upper end of the drum and forming a central opening and lateral channels, and a deflecting plate resting on or secured to the grate, substantially as described.

In testimony whereof I affix my signature in presence of two witnesses.

CHARLES HEMJE.

Witnesses:

JOHN GEOGHAN,
A. MCINNIS.