

Oct. 25, 1949.

L. A. LEHRMAN
SNUBBED CAR TRUCK

2,485,970

Filed Dec. 15, 1944

3 Sheets-Sheet 1

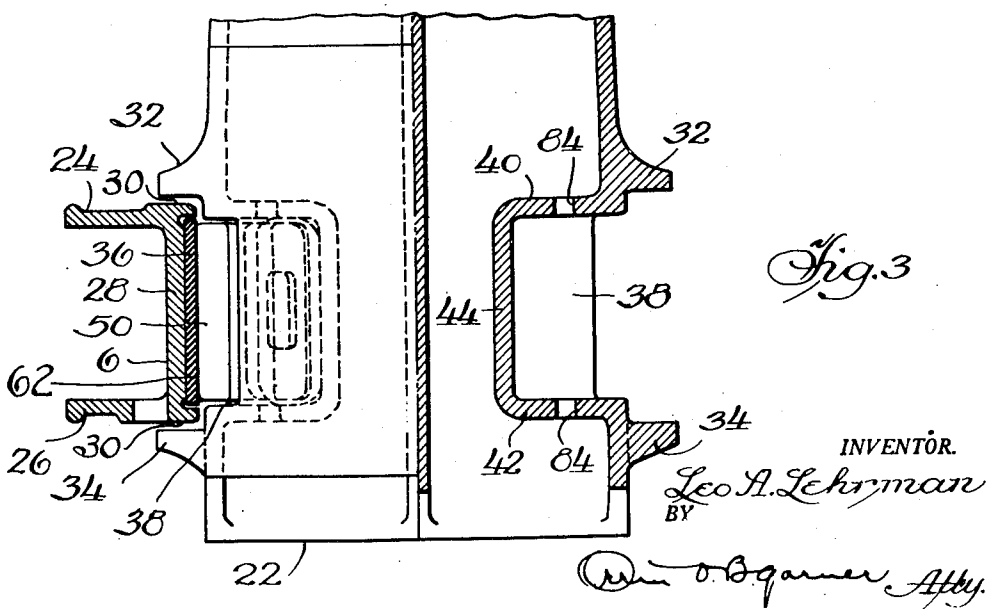
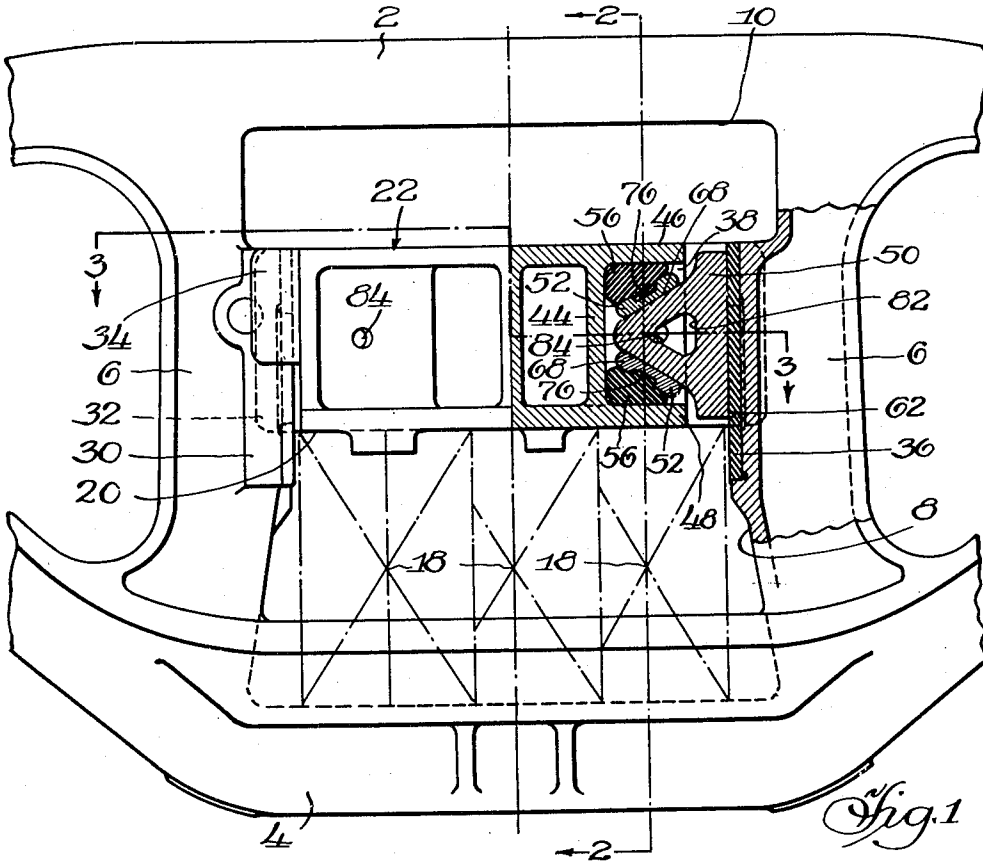

Oct. 25, 1949.

L. A. LEHRMAN
SNUBBED CAR TRUCK

2,485,970

Filed Dec. 15, 1944

3 Sheets-Sheet 2

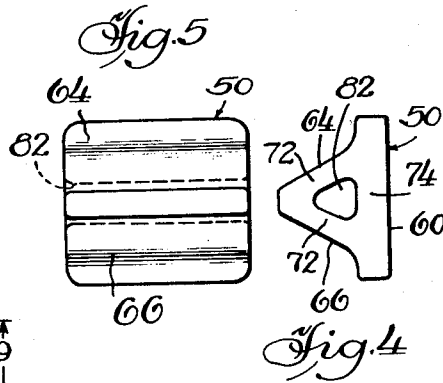
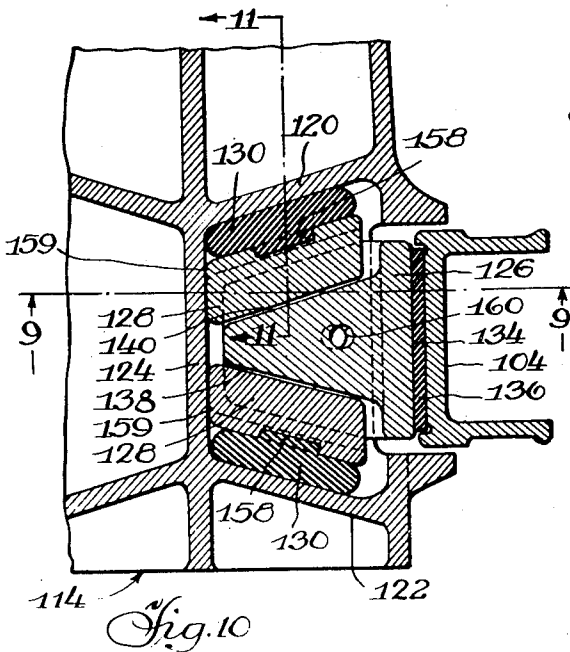
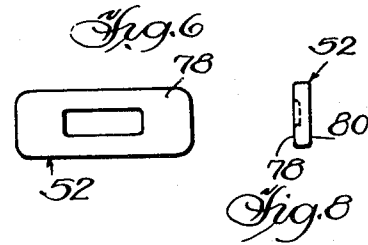
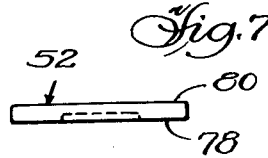
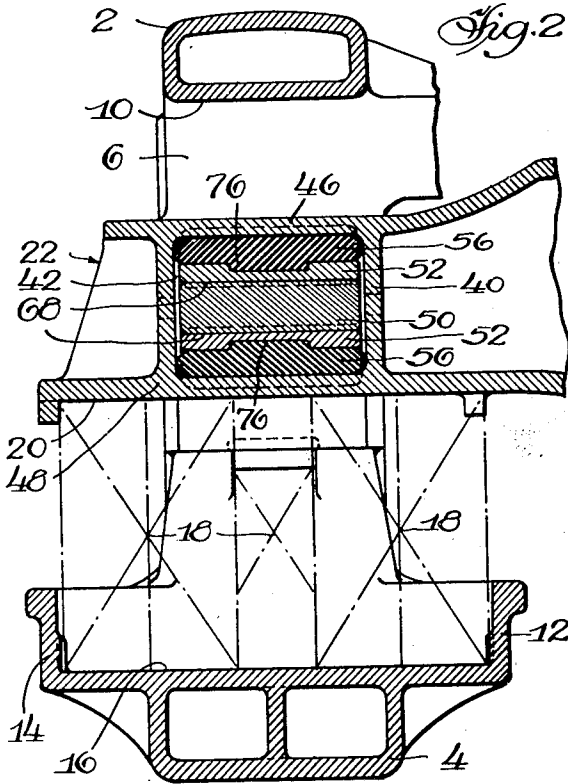

INVENTOR.

Leo A. Lehrman
BY

Wm. O. B. Farmer
Atty.

Oct. 25, 1949.

L. A. LEHRMAN
SNUBBED CAR TRUCK

2,485,970

Filed Dec. 15, 1944

3 Sheets-Sheet 3

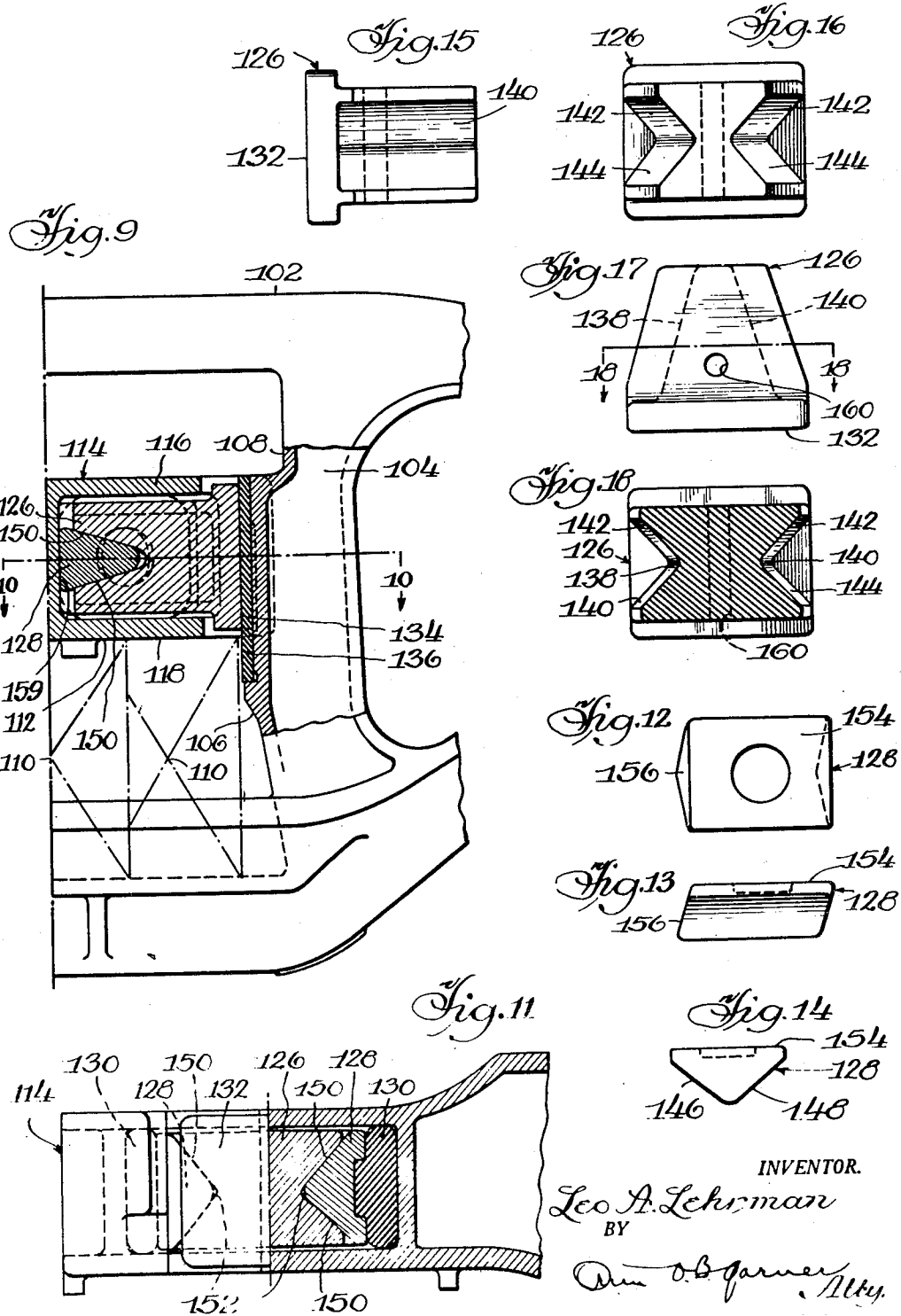

INVENTOR.
Leo A. Lehrman
BY
Ann O. Garner, Atty.

UNITED STATES PATENT OFFICE

2,485,970

SNUBBED CAR TRUCK

Leo A. Lehrman, Chicago, Ill., assignor to American Steel Foundries, Chicago, Ill., a corporation of New Jersey

Application December 15, 1944, Serial No. 568,232

21 Claims. (Cl. 105—197)

1

My invention relates to railway car trucks and more particularly to a type of such truck generally known as quick wheel change wherein the bolster end may be disassembled with respect to the side frame to permit wheel removal.

The general object of my invention is to design such a truck incorporating a snubbing device by means of which frictional control is afforded of the oscillations of the bolster supporting spring group.

A specific object of my invention is to design an improved form of such truck wherein the bolster end may incorporate friction means comprising friction shoes having a friction surface for frictional engagement with an adjacent column wall and each shoe having operatively associated therewith wedge means resiliently mounted in the bolster end.

A further object of my invention is to provide a novel form of car truck wherein the load-carrying member or bolster, resiliently supported on the spaced side frames, may have pockets in each side thereof carrying friction shoes, each of which may frictionally cooperate with a wall of the adjacent side frame column by means of resilient wedge units each compressed between the walls of the pocket and a wedge surface on the shoe.

My invention further comprehends a modification in which each shoe may be formed with diagonally arranged V-section walls on one side thereof against which may seat the respective wedge members of a pair, each shoe having a friction surface on the opposite side thereof urged into frictional engagement with an adjacent column wall by resilient means reacting against each wedge member and portions of the bolster.

In the drawings,

Figure 1 is a fragmentary side elevation of a railway car truck comprising one embodiment of my invention, with the right half of the bolster and the associated friction means shown in section in approximately a vertical longitudinal plane bisecting the side frame.

Figure 2 is a fragmentary sectional view taken substantially in the vertical transverse plane bisecting the truck as indicated by the line 2—2 of Figure 1.

Figure 3 is a fragmentary sectional view of the structure shown in Figures 1 and 2 with the side frame in section through one of the columns, the section being taken in the transverse horizontal plane indicated by the line 3—3 of Figure 1 with the right half of the bolster being shown in section with the associated friction means dissociated therefrom.

2

Figures 4 and 5 show my novel friction shoe utilized in Figures 1 to 3, Figure 4 being a side elevation, and Figure 5 a view taken from the left as seen in Figure 4.

Figures 6, 7 and 8 illustrate my novel form of wear member utilized in Figures 1—3 inclusive, Figure 6 being a plan view thereof, Figure 7 a side elevation, and Figure 8 being an end view.

Figure 9—11 inclusive illustrate a modification of my invention, Figure 9 being a fragmentary side elevation of a railway car truck with the bolster end and the associated friction means and column shown in section, the section being taken approximately in the longitudinal vertical plane bisecting the side frame as indicated by the line 9—9 of Figure 10. Figure 10 is a fragmentary sectional view taken in the transverse horizontal plane indicated by the line 10—10 of Figure 9, and Figure 11 is a side elevation of the bolster with the right half in section, the section being taken as indicated by the line 11—11 of Figure 10.

Figures 12—14 show my novel wedge or wear member utilized in Figures 9—11, Figure 12 being a side elevational view, Figure 13 being a plan view, and Figure 14 being an end view.

Figures 15—18 illustrate my novel friction shoe utilized in Figures 9—11, Figure 15 being a side elevation, Figure 16 being an end view taken from the right as seen in Figure 15, Figure 17 being a top plan view, and Figure 18 being a sectional view taken through the shoe approximately in the plane indicated by the line 18—18 of Figure 17.

Describing my novel truck in detail and referring first to the embodiment thereof illustrated in Figures 1—8 inclusive, the side frame comprises a compression member 2 and a tension member 4 merging adjacent each end thereof with a column 6 to define a bolster opening 8 having a widened upper portion 10 for a purpose hereinafter more fully described. The tension member 4 below the opening 8 may be formed with a widened top chord having upstanding inboard and outboard flanges 12 and 14 defining the spring seat 16 upon which may be positioned a plurality of coil springs 18, 18 affording support as at 20 for the adjacent end of the bolster generally designated 22. Each column may be of U-section having an inboard web 24, an outboard web 26, and a transverse web or wall 28, the central portion of which may be formed with bolster guide means as at 30 affording abutment for the inboard and outboard guide lugs 32 and 34 along the adjacent wall of the bolster. The bolster guide portion of each column may be relieved to receive a wear plate as

illustrated at 36 (Figures 1 and 3) fixed to the columns in any convenient manner.

The bolster 22 may be of box section with a pocket 38 in each side thereof receiving there-within the associated friction means, said pocket being defined by inboard and outboard webs 40 and 42 and by the rear web 44, said webs merging with the top and bottom walls 46 and 48 of the bolster. It may be noted from a consideration of Figure 1 that the outboard guide lugs 34 of the bolster on each side of said pocket may be of less depth than that of the widened upper portion 10 of the bolster opening whereby the bolster may be elevated in said opening and removed therefrom while the bolster and the associated friction means remain in normal assembled relationship, as hereinafter described.

The friction means in each pocket comprises a friction shoe 50, identical wear members 52 and identical rubber pads 56. Each friction shoe is a generally triangular structure having a flat friction face 60 (Figure 8) which may bear as at 62 (Figure 1) against the wear plate 36 on the adjacent column wall. The friction shoe may have diagonally arranged wedge faces 64 and 66 for cooperation as at 68 (Figures 1 and 2) with the top and bottom wear members 52, 52. Each shoe is a three-walled structure having the wedge engaging walls 72, 72 and the column engaging wall 74 and, due to its triangular form, may be wedged outwardly against the adjacent column as at 62 by the wear members urged against the wedge faces 64 and 66 by means of the rubber pads 56, each of which may seat against the associated wear member and be provided with a boss 76 received within an opening in the associated wear member, the upper pad 56 bearing against the top wall of the bolster and the lower pad 56 bearing against the bottom wall of the bolster, each pad also having engagement with the inboard and outboard webs 40 and 42 and the rear web 44, as shown in Figures 1 and 2.

The detail of each of the identical wear members 52 is shown in Figures 6 to 8 and each may be a generally rectangular plate having a plane face 78 (Figures 7 and 8) for engagement with the associated pad 56 which may be vulcanized thereto to form a unitary structure, said face having an opening therein for receiving the boss 76 on the rubber pad. The opposite face 80 of each wear member may also be plane and is adapted to have engagement with one of the wedge surfaces 64 or 66 on the associated shoe. Thus the faces on the wear members may be urged into slidable engagement with the upper and lower wedge surfaces 64 and 66 respectively of the adjacent friction shoe at one side of the bolster, and the shoe into engagement with the adjacent column, by means of the associated rubber pad 56 compressed between the associated wear member and the associated walls of the pocket.

Each shoe may have an opening 82 cored horizontally therethrough and aligned with openings 84, 84 in the inboard and outboard webs of the pocket for the reception of pin means which may position the shoe in assembled relationship with the bolster when the shoe has been compressed into its receded position whereby clearance will be afforded from the adjacent side column to permit the assembly or disassembly of the bolster with the side frame.

A modification of my invention is shown in Figures 9-18 inclusive wherein the side frame generally designated 102 is substantially the same

as that shown in Figure 1, said frame including the spaced columns 104, 104 partially defining the bolster opening 106 having a widened upper portion 108 to permit removal of the bolster and associated friction means from the top of the bolster opening substantially as in the previous embodiment of my invention. Seated on the side frame are the bolster supporting coil springs diagrammatically indicated at 110, 110 and affording support as at 112 for the bolster generally designated 114, said bolster being a box-like structure having a pocket in each side thereof defined by the top and bottom walls 116 and 118, the inboard and outboard diagonal walls 120 and 122 and the rear wall 124 merging therewith.

The friction means received in each pocket comprises the friction shoe 126, the wedge or wear members 128, and the rubber pads 130. Each shoe is a generally rectangular structure having a flat friction face 132 which may bear as at 134 against the wear plate 136 on the adjacent column wall. The friction shoe is formed to provide wedge surfaces 138 and 140 diverging toward the adjacent column, and each wedge surface is formed with angularly arranged top and bottom faces 142 and 144 for complementary engagement with the corresponding faces 146 and 148 of the adjacent V-shaped surface on the associated top and bottom sides of wedge members 128 as at 150, the apex of each wedge member being relieved to afford clearance from the shoe as seen at 152.

The detail of each of the identical wedge members 128 is shown in Figures 12-14 and may be a generally rectangular plate having a plane face 154 which may have fixed thereto the associated rubber pad 130 compressed between the same and the adjacent diagonal side wall of the pocket, said pad being formed with a boss 158 projecting into an opening in the wedge member for positioning the same. The opposite side of each wedge member is V-shaped for complementary wedge engagement with the angularly arranged faces 142 and 144 of the surface 138 or 140 of the adjacent shoe. The one end of each wedge member is preferably formed with a plane surface 156 diagonally arranged with respect to the wedge faces 142 and 144 for sliding engagement as at 159 with the rear wall 124 of the pocket.

It will be apparent that due to the formation of the shoe and the diagonally arranged wedge surfaces 138 and 140 thereof and the complementary wedge engagement of the wedge members therewith and the rear wall of the pocket, both wedge members will bear against the associated friction shoe under the pressure exerted by the pads 130 and tend to urge the shoe into engagement with the wear plate on the adjacent column.

Each shoe is provided with a vertical opening 160 therethrough for alignment with openings in the top and bottom walls of the bolster by means of a shoe positioning pin received within the openings for positioning the shoes in assembled relationship with the bolster, whereby the shoe may be forced into the associated pocket to provide sufficient clearance from the adjacent side column in the assembly or disassembly of the bolster with the side frame.

It will be readily understood by those skilled in the art that in both modifications the wedge engagement of the identical wedge members by the associated shoe, and the engagement of the wedge members by the rubber pads seated against the walls of the pocket, will cause the

5

shoes to be maintained in frictional engagement with the adjacent column walls during horizontal angling of the bolster in that the resultant deformation of the rubber pads does not materially affect their operative engagement with the associated wedge members cooperating with the shoes to urge the latter into engagement with the adjacent column wall. It may be further noted that the rubber pads will tend to assume their original shape, and the resultant reaction of the same against the bolster and wedge members transmitted to the shoes engaged with the columns will tend to maintain the bolster in squared relationship relative to the side frames.

It is to be understood that I do not wish to be limited by the exact embodiments of the device shown which are merely by way of illustration and not limitation as various and other forms of the device will, of course, be apparent to those skilled in the art without departing from the spirit of the invention or the scope of the claims.

I claim:

1. In a railway car truck, a truss side frame having tension and compression members and spaced columns defining a bolster opening, springs on said tension member in said opening, a bolster supported on said springs with guide lugs in cooperative engagement with said columns, said bolster having a box-section end portion with pockets in each side thereof and friction means in each pocket, said friction means comprising a friction shoe having a friction surface in frictional engagement with an adjacent column and wedge faces diverging toward the adjacent column, a pair of members in engagement with respective wedge faces, and resilient means compressed between each member and the walls of said pocket and operative to urge said members against said shoe and said shoe into engagement with the adjacent column, said shoe and members being resiliently supported by said resilient means between the walls of said pocket.

2. In a railway car truck, a truss side frame having tension and compression members and spaced columns defining therewith a bolster opening, springs on said tension member in said opening, a bolster supported on said springs in cooperative engagement with said columns, said bolster having a box-section end portion with pockets in opposite sides thereof and friction means in each pocket, said friction means comprising a friction shoe having diagonally arranged wedge faces at opposite sides thereof, a pair of members in engagement with respective faces, and resilient means at opposite sides of said shoe compressed between said bolster and said members and oriented to exert forces diagonally outwardly of said pocket for urging said members against said shoe and said shoe into frictional engagement with the adjacent column.

3. In a car truck, a truss side frame having tension and compression members and spaced columns defining a bolster opening, a bolster spring-supported between said columns, said bolster having a pocket at each side thereof and friction means resiliently mounted in each pocket, said friction means comprising a friction shoe having diagonally arranged wedge surfaces at the lateral sides thereof, a pair of wedge members in wedge engagement with respective surfaces and having slidable engagement with a wall of said pocket, and resilient means compressed between said members and walls of said pocket arranged substantially parallel to said surfaces and operative to urge said members against said

6

shoe and said shoe into frictional engagement with the adjacent column, each of said wedge surfaces having a plurality of angularly arranged surfaces engaging the adjacent wedge member.

4. In a car truck, a side frame having spaced columns defining in part a bolster opening, a bolster spring-supported on said frame in said opening, said bolster having a pocket in each side thereof, and friction means in each pocket, said friction means comprising a friction shoe having diagonally arranged wedge surfaces sloping toward an adjacent column, wedge members in engagement with respective surfaces, and resilient means compressed between said wedge members and said bolster and operative to urge said wedge members into wedge engagement with said shoe and said shoe into frictional engagement with the adjacent column, said shoe and wedge members being resiliently supported by said resilient means between the walls of said pocket.

5. In a railway car truck, a truss side frame having tension and compression members and spaced columns defining therewith a bolster opening, a bolster spring-supported on said tension member in said opening, said bolster having pockets in each side thereof, and friction means in each pocket, said friction means comprising a bisymmetrical triangular friction shoe having flat face frictional engagement with the adjacent column and wedge faces at opposite sides thereof sloping toward said column, a pair of wedge members engaging respective wedge faces, and resilient means spaced longitudinally of said bolster and disposed at opposite sides of said shoe and operative to urge said wedge members against said shoe and said shoe into engagement with the adjacent column.

6. In a car truck, a truss type side frame having tension and compression members and spaced columns defining a bolster opening, a bolster having an end spring-supported between said columns, said bolster end having a pocket in each side thereof, and frictions means resiliently mounted in each pocket, said friction means comprising a friction shoe having diagonally arranged wedge surfaces, a pair of members in wedge engagement with respective surfaces and having slidable engagement with a wall of said pocket, and resilient means adjacent each surface compressed between the associated member and said bolster, said resilient means being oriented to deliver forces substantially normal to the respective surfaces and being operative to urge said members against said shoe and said shoe into frictional engagement with the adjacent column.

7. In a railway car truck, a side frame having spaced columns defining in part a bolster opening, a bolster end spring-supported on said frame in said opening, and friction means pocketed in each side of said bolster, said friction means comprising a bisymmetrical friction shoe having diagonally arranged wedge faces sloping toward an adjacent column, rigid members in engagement with respective faces, and a pair of rubber elements arranged one between each member and the bolster and oriented to deliver forces substantially normal to the respective faces and operative to urge said members into wedge engagement with said shoe and said shoe into frictional engagement with an adjacent column, each of said wedge faces having a plurality of angularly arranged surfaces engaging the adjacent member.

8. In a car truck, a side frame having spaced columns presenting opposed friction surfaces, a

relatively movable member spring-supported between said columns and comprising friction means at each side thereof adjacent respective columns, said friction means comprising a friction shoe in frictional engagement with an adjacent friction surface and having diagonally arranged faces at the lateral sides thereof sloping toward an adjacent column, a pair of wedge elements in engagement with respective faces, and resilient means spaced longitudinally of said member and compressed between said member and said elements and operative to urge said elements into engagement with said shoe and said shoe into frictional engagement with the adjacent column, each of said resilient means being arranged to deliver forces diagonally toward the adjacent friction surface.

9. In a car truck, a side frame comprising a column member, a relatively movable member supported adjacent thereto, a pocket in one of said members, and friction means in said pocket comprising a friction shoe in frictional engagement with one of said members and having wedge surfaces sloping toward the other member, a pair of wedge elements in engagement with respective surfaces, and resilient means compressed between each element and a face of said pocket substantially parallel to the adjacent surface, said means being operative to urge said elements into engagement with said shoe and said shoe into frictional engagement with said one member.

10. In a car truck, a side frame having spaced columns defining in part a bolster opening, a bolster end spring-supported on said frame in said opening, and friction means housed in each side of said bolster end, said friction means comprising a friction shoe having wedge surfaces sloping toward the adjacent column, a plurality of wedge members in engagement with said surfaces, and resilient means comprising pads of resilient material compressed between respective wedge members and angularly disposed bolster walls arranged substantially parallel to the respective surfaces, said pads being operative to urge said wedge members against said shoe and said shoe into frictional engagement with the adjacent column.

11. In a railway car truck, a side frame having spaced columns defining in part a bolster opening, a bolster end spring-supported on said frame in said opening, and friction means mounted at each side of said bolster end comprising a shoe having a vertical plane face on one side thereof in engagement with an adjacent column and diagonally arranged wedge faces on the opposite side thereof sloping toward an adjacent column, a pair of wedge members in engagement with respective faces, and resilient means compressed between each wedge member and said bolster end and comprising pads of resilient material each oriented to deliver a force substantially perpendicular to the adjacent wedge face.

12. In a bolster for a railway car truck, a box-like end portion with a pocket in each side thereof, and friction means resiliently mounted in said pocket, said friction means comprising a friction shoe having a vertical friction face on one side thereof and diagonally arranged wedge faces on the opposite side thereof, a pair of members in slidable engagement with said wedge faces, and resilient means compressed between converging spaced walls of said pocket and respective members.

13. In a railway car truck, a side frame com-

prising spaced columns and an intervening bolster opening, a bolster supported on said frame in said opening, friction means supported by said bolster at one side thereof, said friction means comprising a friction shoe, wedge members at laterally opposite sides of said shoe and in wedge engagement therewith and in engagement with a wall of said bolster, and rubber means reacting against said bolster and said wedge members and operative to urge the latter against said shoe and said shoe outwardly of said bolster into frictional engagement with an adjacent column, said shoe and wedge members being resiliently supported by said rubber means in spaced relation to the upper and lower portions of said pocket.

14. In a railway car truck, a side frame comprising spaced columns presenting opposed friction faces, a bolster spring-supported on said frame between said columns, a pocket in each side of said bolster, friction means in each pocket, said friction means comprising a friction shoe having diagonally arranged surfaces sloping toward the friction face on the adjacent column, wedge members in slidable engagement with said surfaces, and a pair of resilient elements associated with said wedge members and compressed between the same and angularly arranged walls of said pocket.

15. In a railway car truck, a side frame comprising a column member, a relatively movable member spring-supported on said frame adjacent said column member, a pocket in one of said members adjacent a friction face on the other of said members, a friction shoe in said pocket having wedge faces sloping toward said friction face, wedge members in slidable engagement with said wedge faces, and a resilient pad associated with each wedge member oriented to exert a force diagonally outwardly of said pocket, said pads urging said members toward each other and against the respective wedge faces and thereby said shoe outwardly of said pocket into frictional engagement with said friction face.

16. In a railway car truck, a side frame comprising spaced columns, a bolster spring-supported from said frame between said columns, a pocket in said bolster at each side thereof presenting substantially parallel top and bottom walls, friction means in each pocket, said friction means comprising a friction shoe presenting wedge surfaces diagonally arranged with respect to said walls, plates spaced from said walls and slidably engaging said surfaces, and resilient means reacting against respective walls and operatively urging said plates into wedge engagement with said shoe and thereby said shoe outwardly of said pocket and into frictional engagement with an adjacent column.

17. In a railway car truck, a side frame comprising spaced columns, a bolster of box-section spring-supported on said frame between said columns, a pocket in said bolster at each side thereof, friction means in each pocket comprising a friction shoe having wedge faces sloping toward an adjacent column, wedge members in wedge engagement with respective faces and slidably engaging a wall of said pocket, and resilient means compressed between said members and other walls of said pocket converging inwardly thereof.

18. In a railway car truck, a side frame comprising spaced columns, a bolster spring-supported on said frame between said columns, a pocket in said bolster at one side thereof, friction means in said pocket comprising a friction shoe

in frictional engagement with an adjacent column and presenting diagonally arranged surfaces, wedge members in complementary engagement with said surfaces, and resilient means compressed between said members and angularly arranged walls of said pocket sloping toward an adjacent column.

19. In a railway car truck, a column member, a relatively movable member supported adjacent thereto, a friction surface on one of said members and a pocket in the other of said members, friction means in said pocket comprising a friction shoe having diagonally arranged faces sloping toward said surface, wedge means disposed on opposite sides of said shoe in wedge engagement with said faces and slidably engaging its supporting member, and resilient means at opposite sides of said shoe urging said wedge means toward each other and thereby urging said shoe outwardly of said pocket into frictional engagement with said friction surface, said resilient means yieldably maintaining said wedge means and shoe in spaced relation to the walls of said pocket.

20. In a railway car truck, a side frame comprising a column member, a relatively movable member spring-supported adjacent thereto, a pocket in one of said members, a friction face on the other of said members, friction means in said pocket comprising a friction element in frictional engagement with said face, wedge means in wedge engagement with said element at opposite sides thereof and with its supporting member, and diagonally arranged independent resilient means at opposite sides of said element

reacting against respective means and urging the same into said wedge engagement and said element outwardly of said pocket into said frictional engagement.

21. In a railway car truck, a side frame comprising a column member, a relatively movable member spring-supported adjacent thereto, a pocket in one of said members, friction means in said pocket and comprising a friction shoe having diagonally arranged V-shaped wedge surfaces sloping toward a friction surface on the other of said members, wedge elements in wedge engagement with said surfaces, and resilient pads seated against angularly arranged walls of said pocket and reacting against respective elements to urge the same along another wall of said pocket and toward each other and thereby said shoe outwardly of said pocket into frictional engagement with said friction surface.

LEO A. LEHRMAN.

REFERENCES CITED

The following references are of record in the file of this patent:

UNITED STATES PATENTS

Number	Name	Date
716,294	Shallenberger	Dec. 16, 1902
1,742,003	O'Connor	Dec. 31, 1929
2,333,921	Flesch	Nov. 9, 1943
2,365,198	Lehrman	Dec. 19, 1944
2,365,199	Light	Dec. 19, 1944
2,378,228	Light	June 12, 1945
2,408,866	Marquardt	Oct. 8, 1946