

June 20, 1944.

T. M. FERRILL, JR

2,351,604

INDUCTANCE COIL

Filed Jan. 18, 1941

2 Sheets-Sheet 1

Fig. 1.

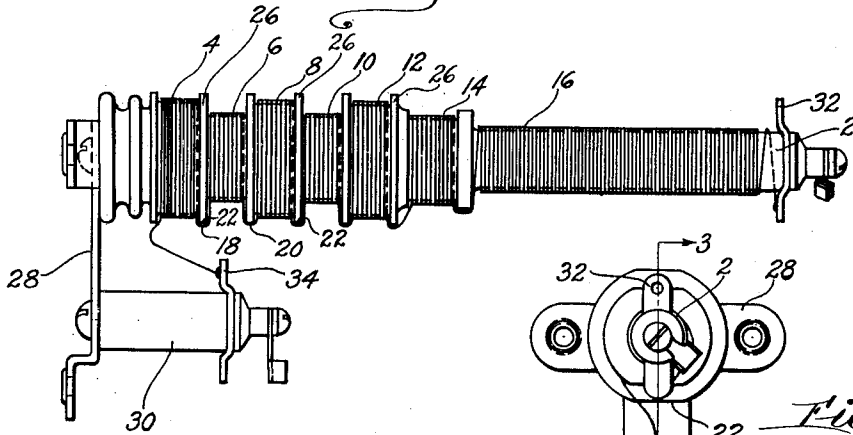

Fig. 2.

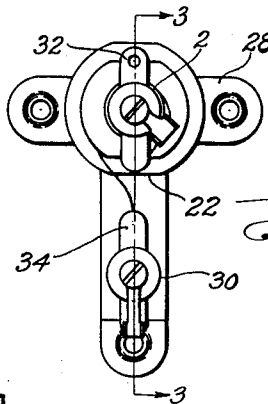

Fig. 3.

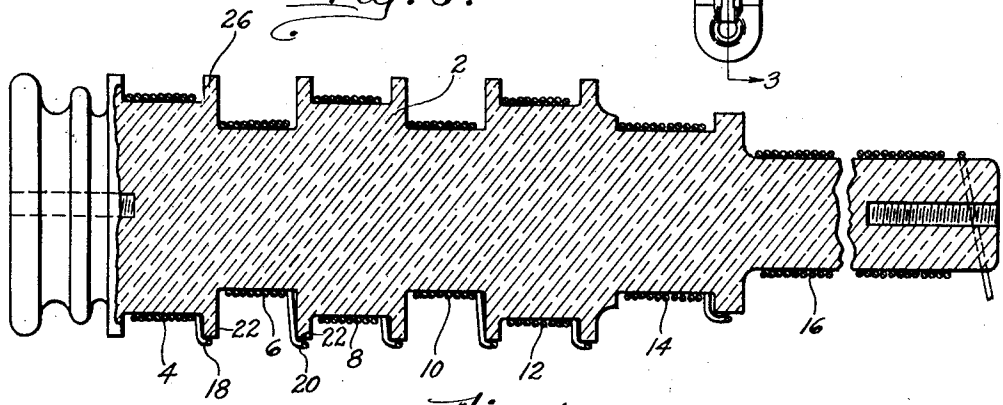
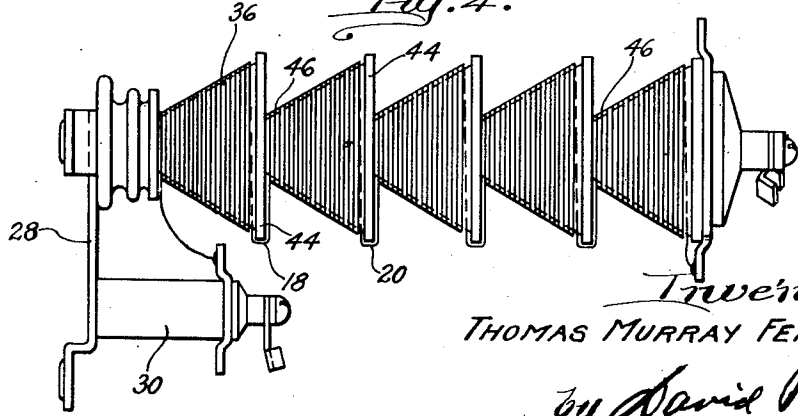

Fig. 4.



Inventor.
THOMAS MURRAY FERRILL, JR.

by David P. Rie
Atty.

June 20, 1944.

T. M. FERRILL, JR

2,351,604

INDUCTANCE COIL

Filed Jan. 18, 1941

2 Sheets-Sheet 2

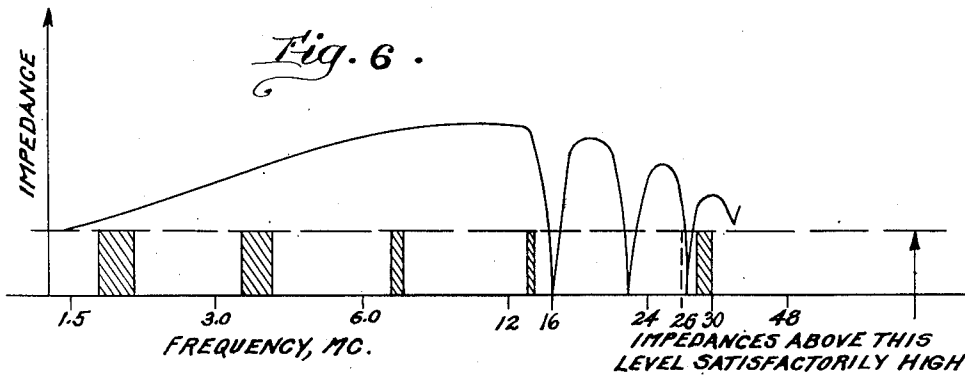
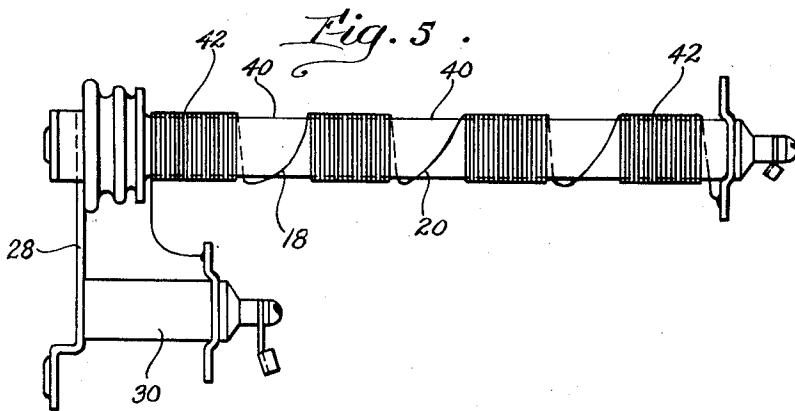

Inventor.
THOMAS MURRAY FERRILL, JR.

by David R. Davis
Att'y.

UNITED STATES PATENT OFFICE

2,351,604

INDUCTANCE COIL

Thomas M. Ferrill, Jr., Mineola, N. Y., assignor to
National Company, Inc., Malden, Mass., a cor-
poration of Massachusetts

Application January 18, 1941, Serial No. 375,055

20 Claims. (Cl. 175—359)

The present invention relates to inductance coils, and more particularly to radio-frequency choke coils.

As is well known, it is not possible to produce a coil the impedance of which shall be solely inductive at all frequencies. No matter how carefully the materials of the coil are chosen, and no matter how scrupulously it is designed, the coil will have at least some capacitance, due to the fact that a condenser action takes place between adjacent convolutions. This well recognized capacitance is designated in the art as the distributed capacitance of the coil.

An object of the present invention is to provide a new and improved coil the distributed capacitance of which shall be greatly reduced.

Other and further objects will be explained hereinafter, and will be particularly pointed out in the appended claims.

The invention will now be explained more fully in connection with the accompanying drawings in which Fig. 1 is a side elevation of a coil embodying the invention in preferred form; Fig. 2 is a plan of the same; Fig. 3 is a section, upon an enlarged scale, taken substantially upon the line 3—3 of Fig. 2, looking in the direction of the arrows, a part being broken away; Figs. 4 and 5 are views similar to Fig. 1 of modifications; and Fig. 6 is a plot of the impedance, as a function of frequency, of a radio-frequency choke coil embodying the present invention.

According to a preferred embodiment of the invention, illustrated in Figs. 1, 2 and 3, the coil is constituted of a plurality of cylindrical single-layer windings, occupying different axial positions, upon an insulating supporting structure 2, and with the diameters of adjacent windings of abruptly different value, so that the adjacent windings are abruptly spaced radially. The diameter of the first layer winding 4, for example, is abruptly different from that of the next-adjacent, second layer winding 6, the diameter of the second layer winding 6 is abruptly different from that of the next-adjacent, third layer winding 8, and so on. Further single-layer windings 10, 12, 14 and 16 are shown in the preferred embodiment of the invention, illustrated in Figs. 1, 2 and 3. The alternately disposed windings 4, 8 and 12 are shown as of one diameter, the windings 6, 10 and 14 of another diameter, and the terminal layer winding 16 of still another, and of smallest, diameter; and the windings 4, 6, 8, 10, 12 and 14 are shown as of about the same length, and shorter than the layer winding 16. This, how-

ever, is of little consequence, so long as no two adjacent windings have the same diameter.

The windings are continuously connected together, being made from a single wire, with the end or terminal convolution of each winding abruptly separated from the beginning convolution of the winding adjacently disposed thereto, the abrupt separation being spanned by the connecting wire extending between these terminal convolutions.

The right-hand-end convolution of the winding 4, for example, is connected continuously by a connecting wire 18 to the left-hand-end convolution of the layer 6, and the right-hand-end convolution of the latter, continuously by a connecting wire 20 to the left-hand-end convolution of the winding 8. The connecting wire portions 18, 20, and so on, pass over flattened portions 22 disposed upon insulating rings 24 integrally formed upon the supporting structure 2.

By reason of the fact that the windings 4, 6, 8, 10, 12, 14 and 16 are constituted of single layers, there is less distributed capacitance than is the case with windings having a plurality of layers wound one about the other; for each of such plurality of layers would introduce a distributed capacitance by reason of its propinquity to another such layer. Even that less distributed capacitance of the single layer, furthermore, is reduced by abruptly separating each single-layer winding from its adjacent single-layer winding, as by having successively adjacent windings of abruptly different diameter.

Theoretically, the maximum desired effect would be produced by having the diameters or other cross dimensions of the adjacent windings as far different as possible, and by having the number of convolutions in each single-layer winding as small as possible. For reasons of convenience, however, it is desirable to have a reasonable number of convolutions in each winding and it is not necessary that the difference in diameters be exceedingly great. A radio-frequency choke coil, as illustrated in Fig. 1, and having an impedance characteristic such as is indicated in Fig. 6, has been found to have very satisfactory operation with a very high inductive impedance, as illustrated by the plot of the said Fig. 6, over a frequency range from 1.5 to 15 megacycles, and from 27 megacycles through and beyond 30 megacycles. With this very small unit, it is thus possible to include the amateur radio-frequency bands, in particular, 1.715 to 2.0, 3.5 to 4, 7 to 7.3, 14 to 14.4 and 28 to 30 megacycles, as indicated by the shaded areas of

Fig. 6. This high inductive impedance is obtained by reason of the fact that, though the inductance of the coil is high, its distributed capacitance is rather low.

One end of the insulating supporting structure 2 is shown supported upon a three-legged base 28 that supports also a small insulating pillar 30. One end of the coil is connected to a terminal 32 at the other end of the supporting structure 2, and the other end of the coil is connected to a terminal 34 supported by the pillar 30.

The invention is obviously not restricted to use with cylindrical windings. Conical windings 36, for example, are illustrated in Fig. 4, where the connecting wires 18, 20, and so on, are shown extending from the base 44 of one cone to the apex 46 of the next-adjacent cone. It is not absolutely essential, indeed, that the windings, if cylindrical, be of different diameter. If sufficiently separated axially from one another, abruptly, as by means of axial gaps 40, as illustrated in Fig. 5, the windings 42 may be of the same diameter, with the connecting wires 18, 20, and so on, extending from the right-hand-end or end-terminal convolution of one winding to the left-hand-end or beginning-terminal convolution of the next-adjacent winding. In all cases, however, the coil comprises a plurality of single-layer windings that are abruptly separated from one another, and with the successive convolutions of each winding disposed at successively more distant positions axially of the windings.

The single-layer windings are shown with each convolution of each winding compactly disposed in contact with the convolutions adjacent thereto. If these convolutions were not compactly so disposed, of course, even less distributed capacitance would be introduced. The inductance, however, would likewise be reduced, because, owing to the increased length of the coil, the inductance per turn factor of the coil would be less. Separated windings of the same diameter, as illustrated in Fig. 5, are less desirable from this point of view. Not only is the over-all length of the radio-frequency choke coil far greater than with the other illustrated arrangements, but the inductance per turn or convolution is also less. It is accordingly preferred, as illustrated in the remaining figures, to employ adjacently disposed windings the radial dimensions of which are abruptly different.

Further modifications will occur to persons skilled in the art, and all such are considered to fall within the spirit and scope of the invention, as defined in the appended claims.

What is claimed is:

1. An inductance coil comprising a plurality of single-layer continuously connected windings, the cross-dimensions of adjacently disposed windings having abruptly different values.

2. An inductance coil comprising a plurality of single-layer continuously connected windings occupying different axial positions, adjacent portions of adjacent windings having abruptly different cross-dimensions.

3. An inductance coil comprising a plurality of single-layer continuously connected cylindrical windings occupying different axial positions, the diameters of adjacent windings having abruptly different values.

4. An inductance coil constituted of a plurality of abruptly separated single-layer windings occupying different axial positions and continuously connected together by connecting wires, each convolution of each winding being compactly disposed in contact with the convolutions adjacent

thereto but with successive convolutions of each winding disposed at successively more distant positions axially of the windings, and the wire connecting adjacent windings extending from an end-terminal convolution of one winding that is abruptly separated from a beginning-terminal convolution of the winding disposed adjacent thereto.

5. An inductance coil constituted of a plurality of abruptly separated single-layer windings occupying different axial positions and continuously connected together by connecting wires, each convolution of each winding being compactly disposed in contact with the convolutions adjacent thereto but with successive convolutions of each winding disposed at successively more distant positions axially of the windings, the wire connecting adjacent windings extending from an end-terminal convolution of one winding that is abruptly separated from a beginning-terminal convolution of the winding disposed adjacent thereto, and the cross-dimensions of the adjacently disposed windings having abruptly different values.

6. An inductance coil constituted of a plurality of abruptly separated cylindrical single-layer windings occupying different axial positions and continuously connected together by connecting wires, each convolution of each winding being compactly disposed in contact with the convolutions adjacent thereto but with successive convolutions of each winding disposed at successively more distant positions axially of the windings, and the wire connecting adjacent windings extending from an end-terminal convolution of one winding that is abruptly separated from a beginning-terminal convolution of the winding disposed adjacent thereto.

7. An inductance coil constituted of a plurality of abruptly separated cylindrical single-layer windings occupying different axial positions and continuously connected together by connecting wires, each convolution of each winding being compactly disposed in contact with the convolutions adjacent thereto but with successive convolutions of each winding disposed at successively more distant positions axially of the windings, the wire connecting adjacent windings extending from an end-terminal convolution of one winding that is abruptly separated from a beginning-terminal convolution of the winding disposed adjacent thereto, and the diameters of adjacently disposed windings having abruptly different values.

8. An inductance coil constituted of a plurality of abruptly separated cylindrical single-layer windings occupying different axial positions and continuously connected together by connecting wires, each convolution of each winding being compactly disposed in contact with the convolutions adjacent thereto but with successive convolutions of each winding disposed at successively more distant positions axially of the windings, the wire connecting adjacent windings extending from an end-terminal convolution of one winding that is abruptly separated from a beginning-terminal convolution of the winding disposed adjacent thereto, the diameters of adjacently disposed windings having abruptly different values, and alternately disposed windings having one diameter and the remaining windings another diameter.

9. An inductance coil constituted of a plurality of abruptly separated cylindrical single-layer windings occupying different axial positions and continuously connected together by connecting wires, each convolution of each winding being

compactly disposed in contact with the convolutions adjacent thereto but with successive convolutions of each winding disposed at successively more distant positions axially of the windings, the wire connecting adjacent windings extending from an end-terminal convolution of one winding that is abruptly separated from a beginning-terminal convolution of the winding disposed adjacent thereto, the diameters of adjacently disposed windings having abruptly different values, alternately disposed windings having one diameter and the remaining windings another diameter, and the windings being disposed adjacent to each other.

10. An inductance coil constituted of a plurality of abruptly separated single-layer cylindrical windings occupying different axial positions and continuously connected together by connecting wires, each convolution of each winding being compactly disposed in contact with the convolutions adjacent thereto but with successive convolutions of each winding disposed at successively more distant positions axially of the windings, the wire connecting adjacent windings extending from an end-terminal convolution of one winding that is abruptly separated from a beginning-terminal convolution of the winding disposed adjacent thereto, the diameters of adjacently disposed windings having abruptly different values, alternately disposed windings having one diameter and the remaining windings another diameter, and a terminal winding being of smallest diameter and longer than the lengths of the other windings, the said other windings being of substantially equal length.

11. An inductance coil constituted of a plurality of abruptly separated single-layer conical windings occupying different axial positions and continuously connected together by connecting wires, each convolution of each winding being compactly disposed in contact with the convolutions adjacent thereto but with successive convolutions of each winding disposed at successively more distant positions axially of the windings, and the wire connecting adjacent windings extending from an end-terminal convolution of one winding that is abruptly separated from a beginning-terminal convolution of the winding disposed adjacent thereto.

12. An inductance coil constituted of a plurality of abruptly separated cylindrical single-layer windings occupying different axial positions and continuously connected together by connecting wires, each convolution of each winding being compactly disposed in contact with the convolutions adjacent thereto but with successive convolutions of each winding disposed at successively more distant positions axially of the windings, the wire connecting adjacent windings extending from an end-terminal convolution of one winding that is abruptly separated from a beginning-terminal convolution of the winding disposed adjacent thereto, and the cylindrical windings being abruptly spaced axially.

13. An inductance coil comprising a plurality of single-layer continuously connected cylindrical windings abruptly spaced radially and occupying different axial positions.

14. An inductance coil comprising a plurality

of single-layer continuously connected windings abruptly spaced radially and occupying different axial positions.

15. An inductance coil constituted of a plurality of abruptly separated single-layer windings occupying different axial positions and continuously connected together by connecting wires, each convolution of each winding being compactly disposed in contact with the convolutions adjacent thereto but with successive convolutions of each winding disposed at successively more distant positions axially of the windings, the wire connecting adjacent windings extending from an end-terminal convolution of one winding that is abruptly separated from a beginning-terminal convolution of the winding disposed adjacent thereto, the cross-dimensions of the adjacently disposed windings having abruptly different values, and a terminal winding being of smallest cross-dimension and longer than the lengths of the other windings.

16. An inductance coil comprising a plurality of single-layer continuously connected windings, the cross-dimensions of adjacently disposed windings having abruptly different values, and alternately disposed windings having one cross-dimension and the remaining windings another cross-dimension.

17. An inductance coil comprising a plurality of single-layer continuously connected windings occupying different axial positions, adjacent portions of adjacent windings having abruptly different cross-dimensions, and alternately disposed windings having one cross-dimension and the remaining windings another cross-dimension.

18. An inductance coil comprising a plurality of single-layer continuously connected cylindrical windings occupying different axial positions, the diameters of adjacent windings having abruptly different values, and alternately disposed windings having one diameter and the remaining windings another diameter.

19. An inductance coil comprising a plurality of single-layer continuously connected cylindrical windings occupying different axial positions, the diameters of adjacent windings having abruptly different values, alternately disposed windings having one diameter and the remaining windings another diameter, and a terminal winding being of smallest diameter and longer than the lengths of the other windings, the said other windings being of substantially equal length.

20. An inductance coil constituted of a plurality of abruptly separated single-layer windings of substantially the same cross-dimension occupying different axial positions and continuously connected together by connecting wires, each convolution of each winding being compactly disposed in contact with the convolutions adjacent thereto but with successive convolutions of each winding disposed at successively more distant positions axially of the windings, the wire connecting adjacent windings extending from an end-terminal convolution of one winding that is abruptly separated from a beginning-terminal convolution of the winding disposed adjacent thereto, and the cylindrical windings being abruptly spaced axially.

THOMAS M. FERRILL, Jr.