



US 20050087577A1

(19) **United States**

(12) **Patent Application Publication**
Thompson

(10) **Pub. No.: US 2005/0087577 A1**

(43) **Pub. Date: Apr. 28, 2005**

(54) **BACKPACK HAVING A SHOULDER STRAP MOUNTED LIFT BUCKLE**

Publication Classification

(75) Inventor: **Jesse Thompson, Bozeman, MT (US)**

(51) **Int. Cl.7** **A45F 3/04**

(52) **U.S. Cl.** **224/641; 224/637; 224/643**

Correspondence Address:

**CHRISTENSEN, O'CONNOR, JOHNSON,
KINDNESS, PLLC
1420 FIFTH AVENUE
SUITE 2800
SEATTLE, WA 98101-2347 (US)**

(57) **ABSTRACT**

A backpack having a storage compartment (134) and a shoulder strap assembly (129a) attached at a first end to the storage compartment at a first location (140) and coupled at a second end to the storage compartment at a second location spaced from the first location. The backpack further includes a buckle (116) attached to the shoulder strap assembly and a lift strap (118) having a first end (120) attached to the upper portion (136) of the storage compartment and spanning above the shoulder strap assembly from its location of attachment to the storage compartment to engagement with the buckle. The buckle is operable to selectively adjust the length of the lift strap to vary the proportion of the weight of the backpack supported by the shoulder strap assembly when engaged by the shoulders of a user wearing the backpack.

(73) Assignee: **K-2 Corporation**

(21) Appl. No.: **10/872,756**

(22) Filed: **Jun. 21, 2004**

Related U.S. Application Data

(63) Continuation of application No. 10/195,664, filed on Jul. 12, 2002, now Pat. No. 6,802,442.

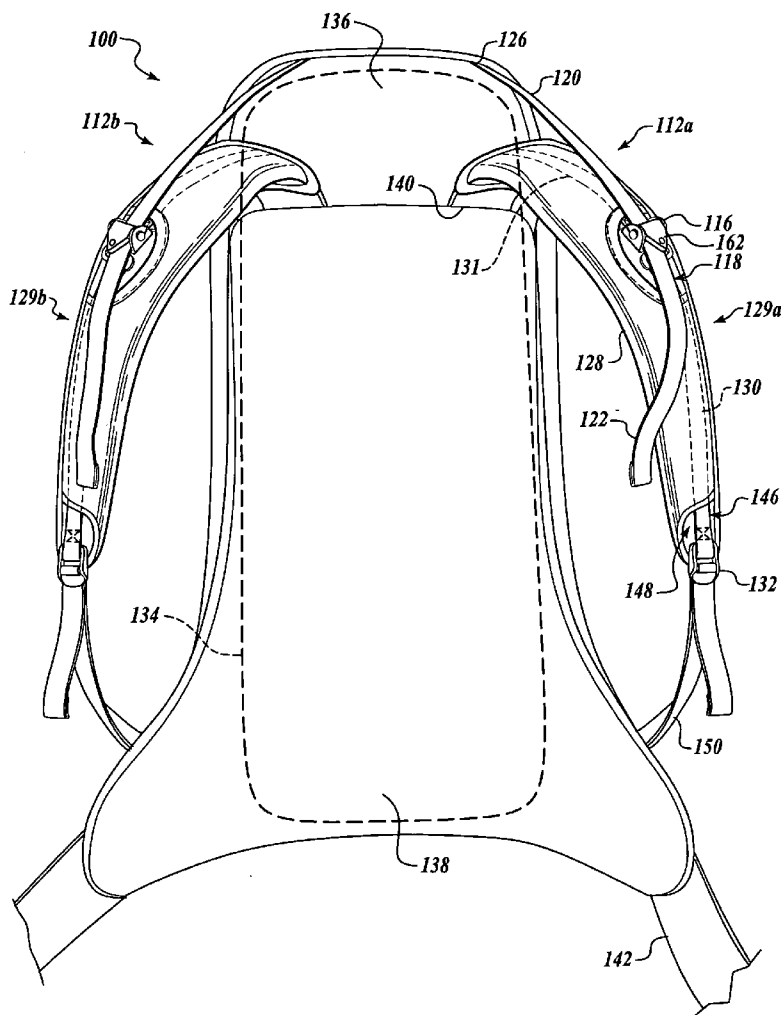

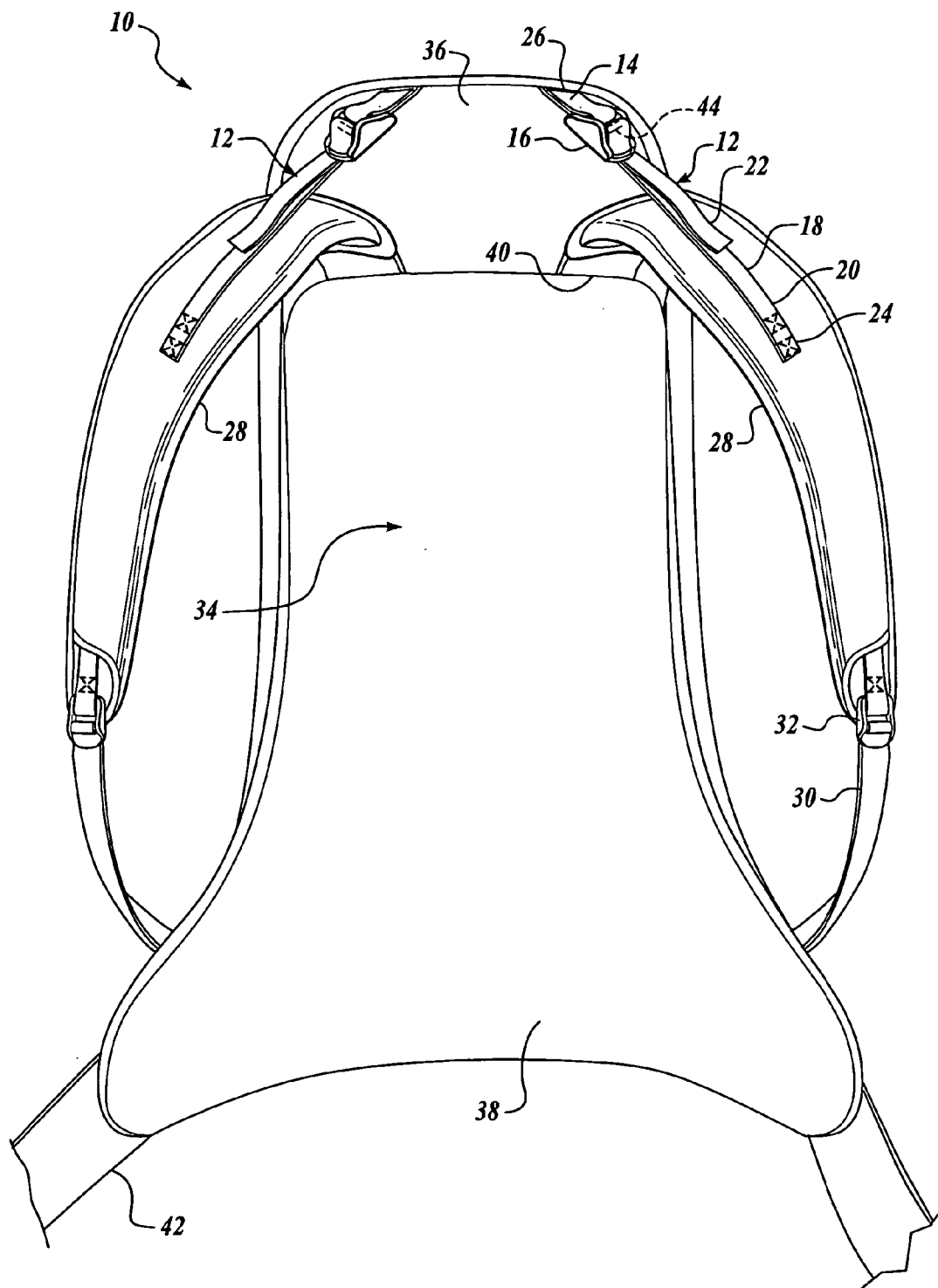

Fig. 1. (PRIOR ART)

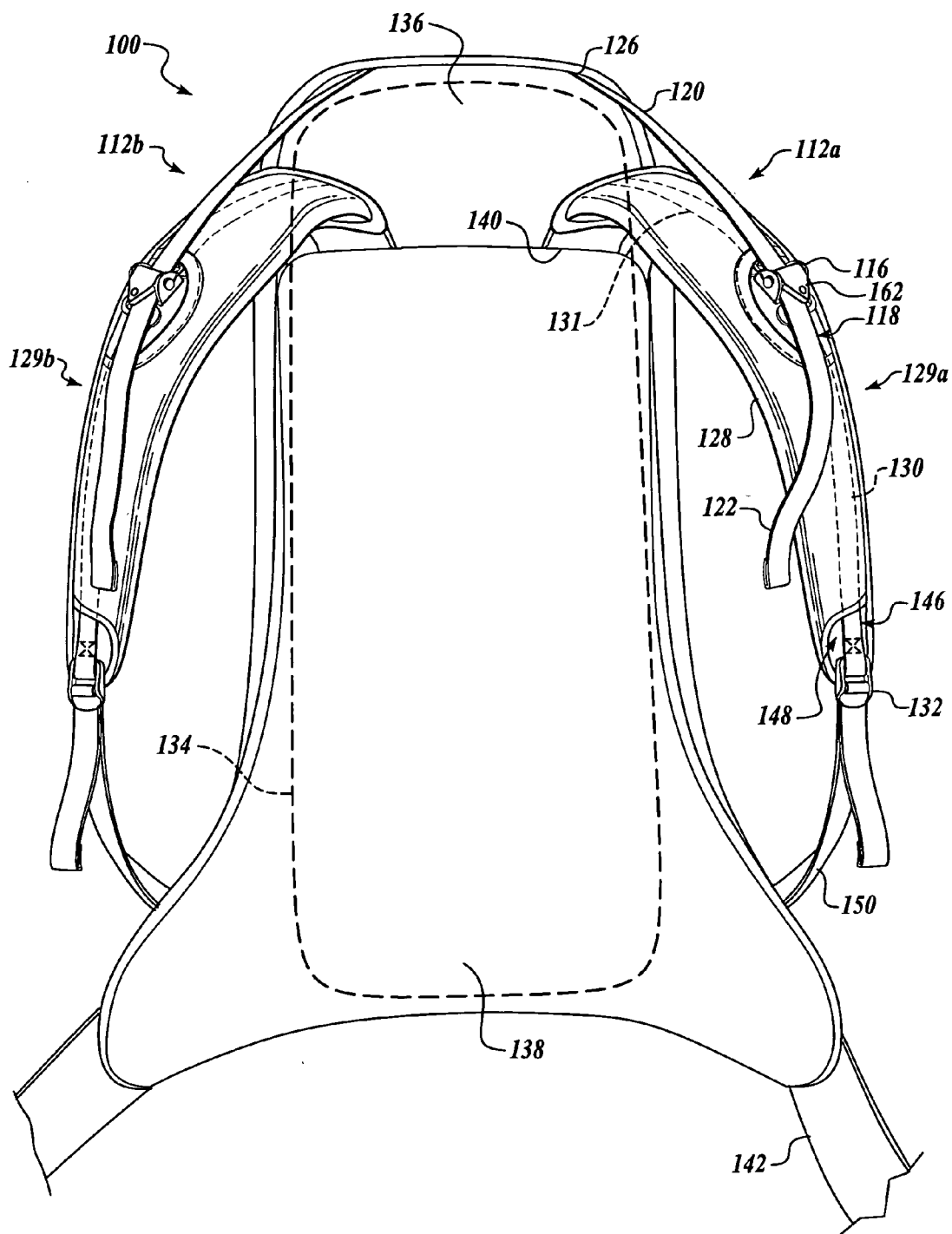
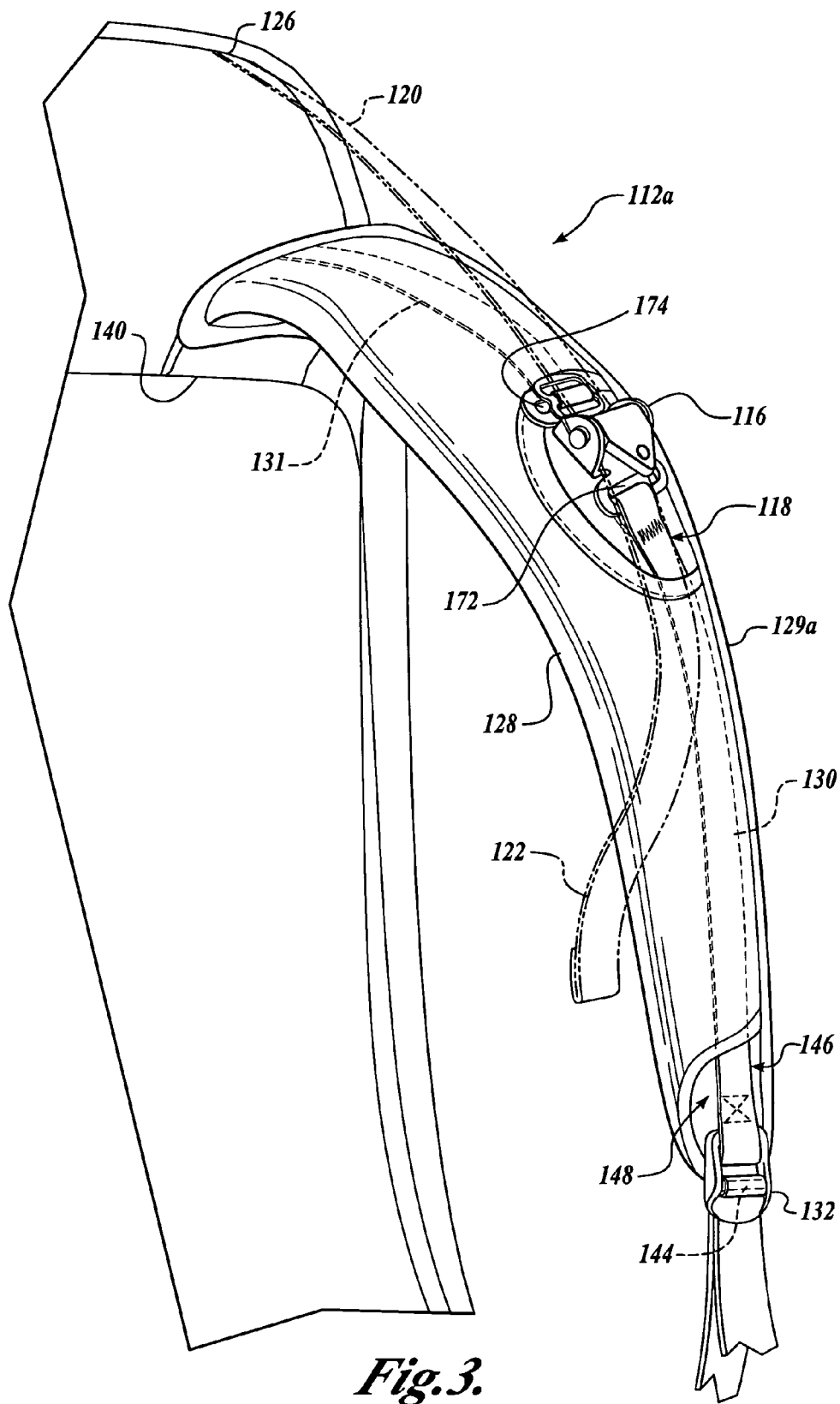

Fig. 2.



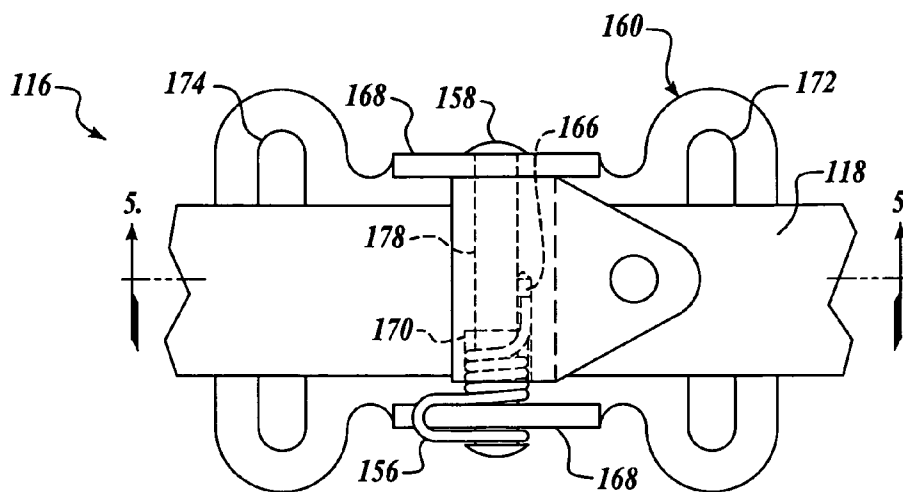

Fig. 4.

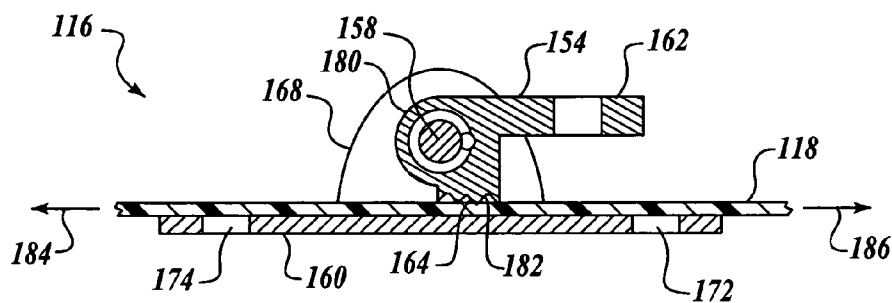

Fig. 5.

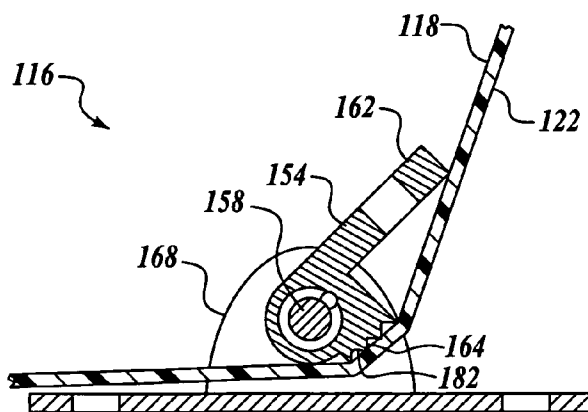

Fig. 6.

BACKPACK HAVING A SHOULDER STRAP MOUNTED LIFT BUCKLE

CROSS-REFERENCE TO RELATED APPLICATION

[0001] This application is a continuation of and claims the benefit of application Ser. No. 10/195,664, filed Jul. 12, 2002, the disclosure of which is hereby expressly incorporated by reference, and the priority from the filing date of which is hereby claimed under 35 U.S.C. § 120.

FIELD OF THE INVENTION

[0002] The present invention relates generally to backpacks and, more particularly, to backpacks having lift straps coupled to the shoulder straps.

BACKGROUND OF THE INVENTION

[0003] Referring to FIG. 1, most conventional backpacks 10 have a pair of shoulder strap assemblies 28 and a waist strap 42 coupled to a storage compartment 34 for holding objects to be carried upon the back of a user. The shoulder strap assemblies 28 and the waist strap 42 distribute the load of the objects carried within the storage compartment 34 upon the shoulders and waist or hips of the user. Although backpacks arranged as described are effective in assisting a user in carrying objects upon the user's back, they are not without problems. For instance, it was found that the ability to adjust the ratio of weight borne by the shoulders relative to the waist of the user was desirable. To accomplish this function, conventional backpacks have incorporated a pair of lift strap assemblies 12 which interconnect an upper portion 36 of the backpack 10 to the shoulder strap assemblies 28. By tightening the lift strap assemblies 12, a higher percentage of the load carried by the backpack 10 is borne by the waist strap 42. In contrast, by loosening the lift strap assemblies 12, a higher percentage of the load carried by the backpack 10 is carried by the shoulder strap assemblies 28.

[0004] Focusing now on the left lift strap assembly 12, a first end 20 of the lift strap 18 is rigidly affixed to the shoulder strap assembly 28 by stitching 24. The lift strap 18 then engages a buckle 16 attached to the upper portion 36 of the storage compartment 34 by a short anchor strap 14 at attachment location 26. The lift strap 18 is engaged with the buckle 16 by passing the second free end 22 of the lift strap 18 around at least one friction bar 44. The friction created by the change of direction of the lift strap 18 as the lift strap 18 encircles the friction bar 44 impedes the movement of the lift strap assembly 12 relative to the buckle until the buckle 16 is manipulated by the user.

[0005] To tighten the lift strap assembly 12, a user must raise his/her hand up above his/her head to grasp the free end 22 of the lift strap 18. Upon grasping the lift strap 18, the free end of the lift strap is forcefully pulled outward and away from the buckle 16. The force required to "shorten" the lift strap assembly 12 is substantial since the force exerted upon the free end 22 of the lift strap 18 must overcome any load on the lift strap 18 and all friction forces created by the engagement of the lift strap 18 with the friction bar 44 of the buckle 16. The harder one pulls of the lift strap, the greater the load placed upon the friction bar 44, and thus the greater the friction force that must be overcome to tighten the lift strap 18.

[0006] To "lengthen" the lift strap assembly 12, a user must reach up and above the user's head and grasp the buckle 16. The buckle 16 is then rotated to manipulate the angle which the lift strap 18 enters and exits the buckle to partially disengage the lift strap 18 from the friction bar 44, to permit the lift strap 18 to pass through the buckle 16, to lengthen the lift strap assembly 12.

[0007] Although conventional backpacks having lift straps may be effective, they are not without problems. For instance, to shorten the lift strap assembly 12, the user must exert a substantial force upon the free end 22 of the lift strap 18. This force must be sufficiently high to overcome any load on the lift strap 18 and the friction forces exerted by the friction bar 44 as discussed above, which may result in a strain or injury to the user. Further, the shortening of the lift strap assembly 12 in the manner described above may lead to the over tightening of the lift straps 18 which may result in shoulder and chest pain if tightened to an extreme. Further still, the buckle 16 is placed in a location obscured, or at least partially obscured, from sight; therefore buckle adjustment by the user is awkward, time consuming, and potentially injury causing as the user contorts his/her body to try to view the buckle.

[0008] Many of the same disadvantages are realized when a user desires to lengthen the lift strap assembly 12. More specifically, a user must again reach up and to the side of his/her head to obtain access to the buckle 16. Further, the act of reaching up and above one's head may cause a loss of the user's balance, resulting in a fall. This is especially true when a user is wearing a large, heavily loaded backpack. Even further, if the buckle 16 cannot be viewed by twisting one's head around, manipulation of the buckle 16 must occur without visual reference, thereby making the proper operation of the buckle 16 difficult. Further still, some user's may find the physical act of reaching up above one's head difficult or impossible, especially for those having reduced mobility.

[0009] Therefore, there exists a need for a backpack having lift straps that are easy to operate, require less force to adjust, reduce the potential for over tightening, may be adjusted by a means that is easily viewed and accessed by the user, and satisfies the performance expectations of the user.

SUMMARY OF THE INVENTION

[0010] In accordance with one embodiment of the present invention, a backpack including a storage compartment and a shoulder strap assembly attached at a first end to the storage compartment at a first location and coupled at a second end to the storage compartment at a second location spaced from the first location is provided. The backpack further includes a buckle attached to the shoulder strap assembly and a lift strap having a first end attached to the upper portion of the storage compartment and spanning above the shoulder strap assembly from its location of attachment to the storage compartment to engagement with the buckle. The buckle is operable to selectively adjust the length of the lift strap to vary the proportion of the weight of the backpack supported by the shoulder strap assembly when engaged by the shoulders of a user wearing the backpack.

[0011] In accordance with further aspects of one embodiment of the present invention, the lift strap includes a second

end extending beyond the buckle, wherein the buckle is operable to selectively adjust the length of the lift strap through manipulation of the second end of the lift strap. In accordance with still further aspects of one embodiment of the present invention, the buckle is actuatable between a first position, wherein the buckle prevents lift strap movement through the buckle in a first direction, and a second position, wherein the buckle permits movement of the lift strap through the buckle in the first direction. In accordance with yet still further aspects of one embodiment of the present invention, the buckle is actuatable between the first and the second positions through manipulation of a second end of the lift strap extending beyond the buckle. For instance, the buckle may be actuatable from the first position to the second position by increasing the angle of inclination of the second end of the lift strap relative to the buckle. Or, the buckle may be actuatable from the second position to the first position by changing the angle that the second end of the lift strap extends from the buckle.

[0012] In accordance with other aspects of one embodiment of the present invention, the buckle is actuatable between a first position, wherein the buckle impedes lift strap movement through the buckle in a first direction for lengthening the lift strap, but permits lift strap movement through the buckle in a second direction opposite the first direction for shortening the lift strap, and a second position, wherein the buckle permits movement of the lift strap through the buckle in the first direction for lengthening the lift strap. In accordance with still other aspects of one embodiment of the present invention, the buckle includes a cam rotatable between a first position, wherein the cam impedes lift strap movement through the buckle in a first direction, and a second position, wherein the cam permits movement of the lift strap through the buckle in the first direction. The cam may be biased to assume the first position by an elastic member. The cam may engage the lift strap in the first position and at least partially disengage from the lift strap in the second position.

[0013] In accordance with yet still other aspects of one embodiment of the present invention, the backpack may further include a second shoulder strap assembly attached at a first end to the storage compartment at a first location and coupled at a second end to the storage compartment at a second location spaced from the first location and a second buckle attached to the second shoulder strap assembly. The backpack may also include a second lift strap having a first end attached to the upper portion of the storage compartment and spanning above the second shoulder strap assembly from its location of attachment to the storage compartment to engagement with the second buckle. The second buckle may be operable to selectively adjust the length of the second lift strap to vary the proportion of the weight of the backpack supported by the second shoulder strap assembly when engaged by the shoulders of a user wearing the backpack.

[0014] In accordance with additional aspects of one embodiment of the present invention, the backpack may further include a waist strap coupled to the lower portion of the storage compartment and operable to at least partially encircle the waist of a user. Further, the adjustment of the length of the lift strap may selectively adjust the ratio of weight carried by the shoulder strap assembly relative to the waist strap when the backpack is worn by a user. In

accordance with further additional aspects of one embodiment of the present invention, the lift strap passes substantially straight through the buckle without undergoing a substantially change in direction.

BRIEF DESCRIPTION OF THE DRAWINGS

[0015] The foregoing aspects and many of the attendant advantages of this invention will become more readily appreciated as the same become better understood by reference to the following detailed description, when taken in conjunction with the accompanying drawings, wherein:

[0016] **FIG. 1** is an elevation view of a prior art backpack having a lift strap adjustment buckle attached to an upper portion of the backpack;

[0017] **FIG. 2** is an elevation view of one embodiment formed in accordance with the present invention having a lift strap adjustment buckle attached to a shoulder strap assembly;

[0018] **FIG. 3** is a fragmentary view of the shoulder strap assembly and a lift strap assembly of the embodiment depicted in **FIG. 2**;

[0019] **FIG. 4** is a top view of the lift strap adjustment buckle of the embodiment depicted in **FIG. 2**;

[0020] **FIG. 5** is a cross sectional view of the lift strap adjustment buckle depicted in **FIG. 4**, the cross section taken substantially through **SECTION 5-5**, with a cam for engaging a lift strap shown in an engaged position; and

[0021] **FIG. 6** is a cross section view of the lift strap adjustment buckle depicted in **FIG. 4**, the cross section taken substantially through **SECTION 5-5**, with the cam for engaging the lift strap shown in a disengaged position.

DETAILED DESCRIPTION OF THE PREFERRED EMBODIMENT

[0022] **FIGS. 2-6** illustrate one embodiment of a backpack **100** constructed in accordance with the present invention is shown. Referring to **FIGS. 2 and 3**, the backpack **100** is designed to be worn upon the back of a user (not shown) to facilitate the carrying of a load. The backpack **100** includes a pair of lift strap assemblies **112a** and **112b**, a pair of shoulder strap assemblies **129a** and **129b**, and a waist strap **142**, all coupled to a storage compartment **134**. The storage compartment **134** defines a cavity used for the storage of objects to be carried therein. The storage compartment **134** includes an upper portion **136** and a lower portion **138**. Coupled to the upper portion **136** of the storage compartment **134** at attachment location **140** is a first shoulder strap assembly **129a**. The lower end of the first shoulder strap assembly **129a** may be coupled to the lower portion **138** of the storage compartment **134** by stitching (not shown).

[0023] The first shoulder strap assembly **129a** is comprised of a shoulder pad **128** having an inner channel **148** passing therethrough. A shoulder strap **146** passes through the inner channel **148** of the shoulder pad **128**. The shoulder strap **146** is comprised of three sections: an upper shoulder strap section **131**, a middle shoulder strap section **130**, and a lower shoulder strap section **150**. The upper end of the upper shoulder strap section **131** is anchored to the upper portion **136** of the storage compartment **134**. The buckle **116** is mounted on the lower end of the upper shoulder strap

section **131** through the use of an oval eyelet **174**. The upper end of the middle shoulder strap section **130** is also coupled to the buckle **116** through a second oval eyelet **176**. The lower end of the middle shoulder strap section **130** is coupled to a shoulder strap buckle **132**. The lower shoulder strap section **150** is coupled to the shoulder strap buckle **132** and to the lower portion **138** of the storage compartment **134**.

[0024] The shoulder strap buckle **132** is operable to adjust the length of the shoulder strap **146** to provide a comfortable fit for users of various sizes. The shoulder strap buckle **132** has at least one friction bar **144** of which the lower shoulder strap section **150** partially encircles. The friction force imposed by the friction bar **144** upon the lower shoulder strap section **150** prevents the movement of the lower shoulder strap section **150**, as should be apparent to one skilled in the art. The “length” of the lower shoulder strap section **150** is selectively adjusted through manipulation of the shoulder strap buckle **132** to thereby adjust the length of the shoulder strap **146**, as is well known in the art.

[0025] As should be apparent to one skilled in the art, the construction and operation of the first shoulder strap assembly **129a** is substantially similar to that of the second shoulder strap assembly **129b**, therefore for brevity, discussion of the second shoulder strap assembly **129b** has been omitted. Likewise, each of the lift strap assemblies **112a** and **112b** are substantially similar in construction and operation, therefore for brevity, only one lift strap assembly **112a** will be discussed in detail following.

[0026] Focusing now on the lift strap assemblies **112a** and **112b**, the first lift strap assembly **112a** includes a lift strap **118** having a first, upper end **120** and a second free end **122**. The upper end **120** of the lift strap **118** is anchored to the upper portion **136** of the storage compartment **134** at attachment location **126**. The lift strap **118** spans above the shoulder strap assembly **129a** from its attachment location **126** on the storage compartment **134** to a buckle **116** mounted on the shoulder strap assembly **129**. The upper end **120** of the lift strap **118** is defined by the portion of the lift strap **118** extending between the attachment location **126** and the buckle **116**. The free end **122** of the lift strap **118** is defined by the portion of the lift strap **118** extending outward from the buckle **116**.

[0027] Referring to FIGS. 3-6, the buckle **116** of the lift strap assembly **112a** will now be described in further detail. The buckle **116** includes a flat base **160** and a pair of parallel sidewalls **168** spaced from one another and extending perpendicularly from the base **160**. The first oval eyelet **174** is formed at a first end of the base **160**. The first oval eyelet **174** facilitates the attachment of the upper shoulder strap section **131** thereto. The second oval eyelet **172** is formed at the second, opposite end of the base **160** for facilitating the coupling of the middle shoulder strap section **130** thereto. Oriented perpendicular to and spanning between the two sidewalls **168** is a pivot pin **158**. The pivot pin **158** axles a strap engagement member, such as a cam **154**, thereon.

[0028] The cam **154** is comprised of a manually graspable actuation lever **162** projecting from the body portion **180** of the cam **154**. The body portion **180** is cylindrically shaped and has a bore **178** passing concentrically therethrough to receive the pivot pin **158**. The body portion **180** of the cam **154** further includes a jaw portion **164**. The jaw portion **164**

may include a toothed or otherwise textured surface **182**, designed to frictionally engage the lift strap **118** against the base **160** by “pinching” the lift strap **118** between the base **160** and the cam jaw.

[0029] The cam **154** may be biased in an engaged position, such as shown in FIG. 5, by an elastic member, such as a torsion spring **156** as shown in the illustrated embodiment. A first end of the torsion spring **156** is coupled to the cam **154** by insertion of an end of the spring **156** in a spring keeper **166**. The opposite end of the torsion spring **156** engages one of the sidewalls **168** and the pivot pin **158** to prevent rotation of the second end of the spring **156**. The cam **154** is preloaded by the torsion spring **156** so as to bias the cam in the engaged position.

[0030] With the cam **154** in the engaged position, as shown in FIG. 5, the lift strap **118** is prevented from traveling in a first “release” direction as indicated by the arrow identified by the reference numeral **184**. More specifically, a tension imposed upon the lift strap **118** in the release direction **184** tends to rotate the cam **154** in a clockwise direction, thereby causing the textured surface **182** of the jaw of the cam **154** to pinch and hold the lift strap **118** between the base **160** and the cam jaw so as to prevent the “lengthening” movement of the lift strap **118** in the first direction **184** during use.

[0031] To tighten the lift strap **118**, a tension force is applied thereon in a second direction, indicated by the arrow identified by the reference numeral **186**, thus rotating the cam **154** in a counter-clockwise direction. Such rotation of the cam **154** tends to disengage the strap engagement portion **164** from the lift strap **118**. As the jaw of the cam **154** disengages or at least partially disengages from the lift strap **118**, the lift strap **118** may be moved in the second direction (indicated by arrow **186**), thereby tightening the lift strap **118**. Therefore, it should be apparent to one skilled in the art, that the buckle **116** allows the movement of the lift strap **118** in a second direction **186** to tighten the lift strap assembly **112a** while impeding the movement of the lift strap **118** in a first direction **184** to prevent loosening of the lift strap assembly **112a** during use. It should also be apparent to one skilled in the art, that the lift strap **118** passes substantially straight through the buckle **116**, providing a direct route between the lift strap **118** attachment location **126** and the free end **122** of the lift strap **118**. As a result, the force required to tighten the lift strap **118** is reduced from conventional backpacks, since the lift strap **118** does not make any friction creating changes of direction, such as around a buckle friction bar, as in conventional backpacks.

[0032] To permit travel of the lift strap **118** in the first, loosening direction **184**, the cam **154** may be rotated in a counter-clockwise direction to the disengaged position, depicted in FIG. 6. In the disengaged position, the cam **154** has been rotated a sufficient angular displacement so that the jaw **164** of the cam **154** no longer sufficiently compresses the lift strap **118** between the base **160** and the teeth **182** of the strap of the cam jaw to impede movement. Thus, the lift strap **118** may now travel in the first direction **184** to loosen the lift strap assembly **112a**.

[0033] As depicted in FIG. 6, the lift strap **118** itself may be used to actuate the cam **154** between the engaged and disengaged positions. More specifically, the free end **122** of the lift strap **118** may be pulled up and outward to increase

the angle of inclination of the free end **122** relative to the buckle **116**. In doing so, the free end **122** of the lift strap **118** bears against the distal end of the lever **162**, thereby rotating the cam **154** from the engaged position depicted in **FIG. 5**, to the disengaged position depicted in **FIG. 6**. By then decreasing the tension on the lift strap **118**, the load of the backpack **100** will pull the lift strap **118** in the first direction **184**. The movement of the lift strap **118** is partially restrained by the engagement of the lift strap **118** with the jaw **164** and with the distal end of the lever **162**, thus allowing the user to slowly and precisely loosen the lift strap **118**.

[0034] As should be apparent to one skilled in the art, the cam **154** may also be actuated by manual manipulation of the lever **162**. More specifically, a user may reach up and simply push upwardly on the distal end of the lever **162** thereby rotating the cam **154** in a counter-clockwise direction. This toggles the cam **154** from the engaged position depicted in **FIG. 5** to the disengaged position depicted in **FIG. 6**. As the cam jaw is released or partially released from contact with the lift strap **118**, the lift strap will be pulled through the buckle in the first direction **184** by the load of the backpack **100**.

[0035] Referring to **FIG. 2** and in light of the above description of the components of the backpack **100**, the operation of the backpack will now be described. To don the backpack **100**, a user places his/her left arm through the first shoulder strap assembly **112a** and his/her right arm through the second shoulder strap assembly **112b**. The waist strap **142** is placed around the waist of the user and fastened. The length of the shoulder strap assemblies **112a** and **112b** are adjusted through manipulation of the shoulder strap buckles **132** to obtain a comfortable fit. The lift strap assemblies **112a** and **112b** may then be manipulated to adjust the ratio of weight borne by the shoulders relative to the waist or hips of the user. More specifically, by tightening the lift strap assemblies **112a** and **112b**, a higher percentage of the load carried by the backpack **100** is borne by the waist strap **142**. In contrast, by loosening the lift strap assemblies **112a** and **112b**, a higher percentage of the load carried by the backpack **100** is carried by the shoulder strap assemblies **129a** and **129b**.

[0036] To shorten the lift strap assemblies **112a** and **112b**, a user grasps the readily accessible free ends **122** of the lift straps **118** and simply pulls. When a sufficient amount of the load has been transferred to the hips of the user through the waist strap **142**, the user ceases pulling and the buckle **116** automatically engages and holds the lift straps **118** in the desired position. To loosen the lift strap assemblies **112a** and **112b**, the user reaches over and "lifts up" the lever **162** of the buckle **116** to allow the lift strap **118** to retract through the buckle **116**. The lift strap **118** is then tightened to the proper tension as described above. Alternately, the lift strap **118** may be loosened by grasping the free end **122** of the lift strap **118**, and increasing the angle of inclination of the lift strap **118** until the lift strap **118** engages and lifts the lever **162** of the buckle **116** to allow the lift strap **118** to pass through the buckle **116** in a loosening direction. While maintaining the increased angle of inclination of the lift strap **118** relative to the buckle **116**, the user may slowly and precisely lengthen the lift strap assembly **112** until the desired shoulder load is obtained.

[0037] As apparent to one skilled in the art, the lift strap assemblies **112a** and **112b** of the present invention reduce the potential for over tightening of the lift strap assemblies **112a** and **112b**. Referring to **FIG. 1**, prior art devices permit the tightening of the lift strap assemblies **12** to an extreme degree, such as where buckle **16** is in contact with stitching **24** of the first end **20** of the lift strap **18**, potentially causing discomfort and/or injury to the user. In contrast, in the illustrated embodiment, the buckle **116** is not drawn toward the lift strap **118** attachment location **126** by a pulley effect (in the manner of the buckle **16** of the prior art backpack **10**), which might permit the easy over tightening of the lift strap **18** to occur.

[0038] While the preferred embodiment of the invention has been illustrated and described, it will be appreciated that various changes can be made therein without departing from the spirit and scope of the invention.

The embodiments of the invention in which an exclusive property or privilege is claimed are defined as follows:

1. A backpack comprising:

- (a) a storage compartment;
- (b) a shoulder strap assembly attached at a first end to the storage compartment at a first location and coupled at a second end to the storage compartment at a second location spaced from the first location;
- (c) a buckle attached to the shoulder strap assembly;
- (d) a lift strap having a first end attached to the upper portion of the storage compartment and spanning above the shoulder strap assembly from its location of attachment to the storage compartment to engagement with the buckle; and
- (e) wherein the buckle is operable to selectively adjust the length of the lift strap to vary the proportion of the weight of the backpack supported by the shoulder strap assembly when engaged by the shoulders of a user wearing the backpack.

2. The backpack of claim 1, wherein the lift strap includes a second end extending beyond the buckle, wherein the buckle is operable to selectively adjust the length of the lift strap through manipulation of the second end of the lift strap.

3. The backpack of claim 1, wherein the buckle is actuatable between a first position, wherein the buckle prevents lift strap movement through the buckle in a first direction, and a second position, wherein the buckle permits movement of the lift strap through the buckle in the first direction.

4. The backpack of claim 3, wherein the buckle is actuatable between the first and the second positions through manipulation of a second end of the lift strap extending beyond the buckle.

5. The backpack of claim 4, wherein the buckle is actuatable from the first position to the second position by increasing the angle of inclination of the second end of the lift strap relative to the buckle.

6. The backpack of claim 4, wherein the buckle is actuatable from the second position to the first position by changing the angle that the second end of the lift strap extends from the buckle.

7. The backpack of claim 1, wherein the buckle is actuatable between a first position, wherein the buckle

impedes lift strap movement through the buckle in a first direction for lengthening the lift strap, but permits lift strap movement through the buckle in a second direction opposite the first direction for shortening the lift strap, and a second position, wherein the buckle permits movement of the lift strap through the buckle in the first direction for lengthening the lift strap.

8. The backpack of claim 1, wherein the buckle includes a cam rotatable between a first position, wherein the cam impedes lift strap movement through the buckle in a first direction, and a second position, wherein the cam permits movement of the lift strap through the buckle in the first direction.

9. The backpack of claim 8, wherein the cam is biased to assume the first position.

10. The backpack of claim 8, wherein the cam is biased to the first position by an elastic member.

11. The backpack of claim 8, wherein the cam engages the lift strap in the first position and at least partially disengages from the lift strap in the second position.

12. The backpack of claim 1, further including:

(a) a second shoulder strap assembly attached at a first end to the storage compartment at a first location and coupled at a second end to the storage compartment at a second location spaced from the first location;

(b) a second buckle attached to the second shoulder strap assembly;

(c) a second lift strap having a first end attached to the upper portion of the storage compartment and spanning above the second shoulder strap assembly from its location of attachment to the storage compartment to engagement with the second buckle; and

(e) wherein the second buckle is operable to selectively adjust the length of the second lift strap to vary the proportion of the weight of the backpack supported by the second shoulder strap assembly when engaged by the shoulders of a user wearing the backpack.

13. The backpack of claim 1, further comprising a waist strap coupled to the lower portion of the storage compartment and operable to at least partially encircle the waist of a user.

14. The backpack of claim 13, wherein adjustment of the length of the lift strap selectively adjusts the ratio of weight carried by the shoulder strap assembly relative to the waist strap when the backpack is worn by a user.

15. The backpack of claim 1, wherein the lift strap passes substantially straight through the buckle without undergoing a substantially change in direction.

16. A backpack comprising:

(a) a storage compartment;

(b) a shoulder strap assembly attached at a first end to the storage compartment at a first location and coupled at a second end to the storage compartment at a second location spaced from the first location;

(c) a buckle mounted on the shoulder strap assembly;

(d) a lift strap having a first end anchored to the upper portion of the storage compartment and spanning above the shoulder strap assembly from its location of attachment to the storage compartment to engagement with the buckle, wherein the buckle is operable to selec-

tively adjust the length of the lift strap to vary the proportion of the weight of the backpack supported by the shoulder strap assembly when engaged by the shoulders of a user wearing the backpack;

(e) wherein a strap engagement member of the buckle is biased to assume a first position, wherein the strap engagement member impedes lift strap movement through the buckle in a first direction; and

(f) is actuatable to a second position, wherein the strap engagement member permits movement of the lift strap through the buckle in the first direction.

17. The backpack of claim 16, wherein the strap engagement member is actuatable between the first and second positions through manipulation of a second end of the lift strap extending beyond the buckle.

18. The backpack of claim 17, wherein the buckle is actuatable from the first position to the second position by increasing the angle of inclination relative to the buckle of a second end of the lift strap extending outward from the buckle.

19. The backpack of claim 18, wherein the strap engagement member is actuatable from the second position to the first position by changing the angle of the second end of the lift strap that extends from the buckle.

20. The backpack of claim 16, wherein the strap engagement member is a cam rotatable between a first position, wherein the cam impedes lift strap movement through the buckle in a first direction, and a second position, wherein the cam permits movement of the lift strap through the buckle in the first direction.

21. The backpack of claim 16, wherein the strap engagement member is biased to the first position by an elastic member.

22. The backpack of claim 20, wherein the cam engages the lift strap in the first position and at least partially disengages from the lift strap in the second position.

23. The backpack of claim 16, further including:

(a) a second shoulder strap assembly attached at a first end to the storage compartment at a first location and coupled at a second end to the storage compartment at a second location spaced from the first location;

(b) a second buckle attached to the second shoulder strap assembly;

(c) a second lift strap having a first end attached to the storage compartment and spanning above the second shoulder strap assembly from its location of attachment to the storage compartment to engagement with the second buckle, wherein the second buckle is operable to selectively adjust the length of the second lift strap to vary the proportion of the weight of the backpack supported by the second shoulder strap assembly when engaged by the shoulders of a user wearing the backpack;

(d) wherein a second strap engagement member of the second buckle is biased to assume a first position, wherein the strap engagement member impedes second lift strap movement through the second buckle in a first direction; and

(e) is actuatable to a second position, wherein the second strap engagement member permits movement of the lift strap through the second buckle in the first direction.

24. The backpack of claim 16, further comprising a waist strap coupled to the lower portion of the storage compartment and operable to at least partially encircle the waist of a user.

25. The backpack of claim 24, wherein adjustment of the length of the lift strap selectively adjusts the ratio of weight carried by the shoulder strap assembly relative to the waist strap when the backpack is worn by a user.

26. The backpack of claim 16, wherein the lift strap passes substantially straight through the buckle without undergoing a substantially change in direction.

27. A backpack comprising:

- (a) a storage compartment;
- (b) a shoulder strap assembly attached at a first end to an upper portion of the storage compartment at a first location and coupled at a second end to the storage compartment at a second location spaced from the first location;
- (c) a buckle attached to the shoulder strap assembly;
- (d) a lift strap having a first end attached to the upper portion of the storage compartment at an attachment location, wherein the lift strap extends from the attachment location to pass substantially straight through the buckle without undergoing a substantial change in direction; and
- (e) wherein the buckle is operable to selectively adjust the length of the lift strap to vary the proportion of the weight of the backpack supported by the shoulder strap assembly when engaged by the shoulders of a user wearing the backpack.

28. The backpack of claim 27, wherein the lift strap includes a second end extending beyond the buckle, wherein the buckle is operable to selectively adjust the length of the lift strap through manipulation of the second end of the lift strap.

29. The backpack of claim 27, wherein a strap engagement member of the buckle is actuatable between a first position, wherein the strap engagement member prevents lift strap movement through the buckle in a first direction, and a second position, wherein the strap engagement member permits movement of the lift strap through the buckle in the first direction.

30. The backpack of claim 29, wherein the strap engagement member is actuatable between the first position and the second position through manipulation of a second end of the lift strap extending beyond the buckle.

31. The backpack of claim 30, wherein the strap engagement member is actuatable from the first position to the second position by changing the angle that the second end of the lift strap extends from the buckle.

32. The backpack of claim 31, wherein the strap engagement member is actuatable from the second position to the

first position by decreasing the angle of inclination of the second end of the lift strap relative to the buckle.

33. The backpack of claim 27, wherein the strap engagement member is actuatable between a first position, wherein the strap engagement member impedes lift strap movement through the buckle in a first direction for lengthening the lift strap, but permits lift strap movement through the buckle in a second direction opposite the first direction for shortening the lift strap, and a second position wherein the strap engagement member permits movement of the lift strap through the buckle in the first direction for lengthening the lift strap.

34. The backpack of claim 27, wherein the strap engagement member is a cam rotatable between a first position, wherein the cam impedes lift strap movement through the buckle in a first direction, and a second position, wherein the cam permits movement of the lift strap through the buckle in the first direction.

35. The backpack of claim 34, wherein the cam is biased to assume the first position.

36. The backpack of claim 34, wherein the cam is biased to the first position by an elastic member.

37. The backpack of claim 34, wherein the cam engages the lift strap in the first position and at least partially disengages from the lift strap in the second position.

38. The backpack of claim 27, further including:

- (a) a second shoulder strap assembly attached at a first end to the storage compartment at a first location and coupled at a second end to the storage compartment at a second location spaced from the first location;
- (b) a second buckle attached to the second shoulder strap assembly;
- (c) a second lift strap having a first end attached to the upper portion of the storage compartment at an attachment location, wherein the second lift strap extends from the attachment location to pass substantially straight through the second buckle without undergoing a substantial change in direction; and
- (d) wherein the second buckle is operable to selectively adjust the length of the second lift strap to vary the proportion of the weight of the backpack supported by the second shoulder strap assembly when engaged by the shoulders of a user wearing the backpack.

39. The backpack of claim 27, further comprising a waist strap coupled to the lower portion of the storage compartment and operable to at least partially encircle the waist of a user.

40. The backpack of claim 39, wherein adjustment of the length of the lift strap selectively adjusts the proportion of the weight of the backpack supported by the shoulder strap assembly relative to the waist strap when the backpack is worn by a user.

* * * * *