



US 20110155126A1

(19) **United States**

(12) **Patent Application Publication**
De Luca

(10) **Pub. No.: US 2011/0155126 A1**

(43) **Pub. Date: Jun. 30, 2011**

(54) **WAVE GENERATED ENERGY FOCUSING LENS AND REFLECTOR FOR SOLAR CONCENTRATION, COLLECTION, AND HARNESSING**

Publication Classification

(51) **Int. Cl.**
F24J 2/18 (2006.01)
F24J 2/00 (2006.01)
(52) **U.S. Cl.** **126/685; 126/714**
(57) **ABSTRACT**

(76) **Inventor:** **Nicholas P. De Luca**, Vieques, PR (US)

(21) **Appl. No.:** **12/648,889**

(22) **Filed:** **Dec. 29, 2009**

A novel method of concentrating solar energy using wave generators is disclosed. The systems and methods enable the collection of energy over large area at high efficiencies and the concentrating of energy at a target for use and transfer.

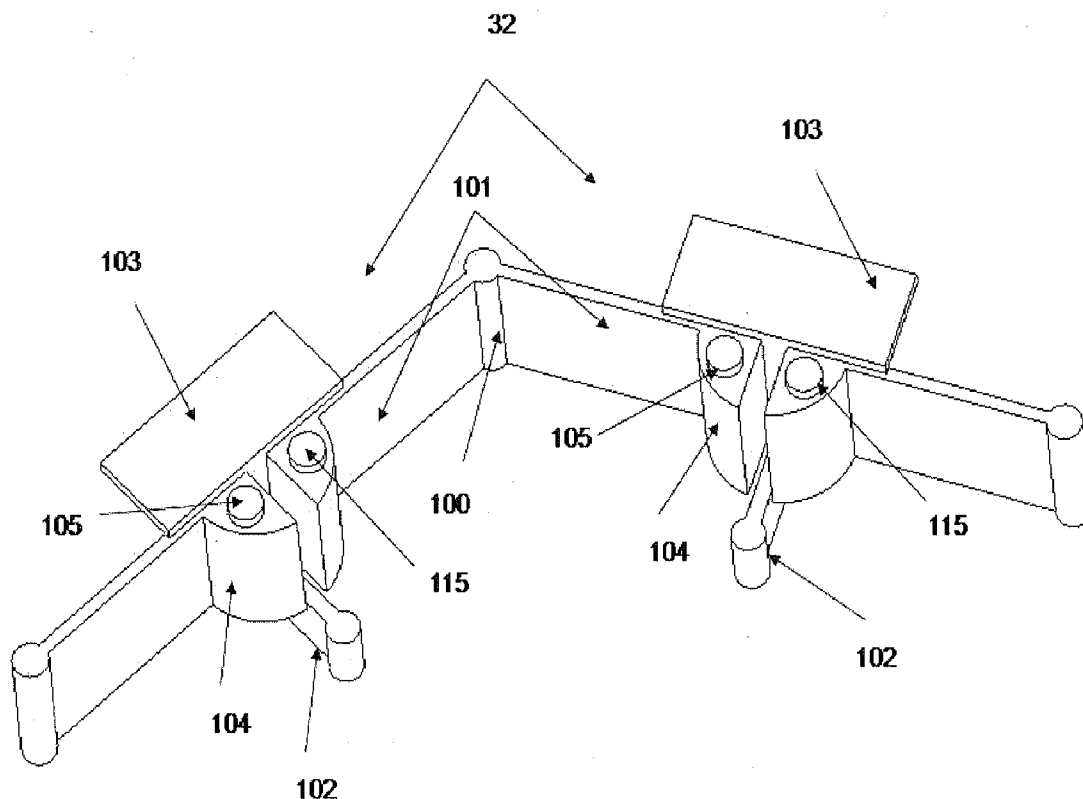

Fig. 1

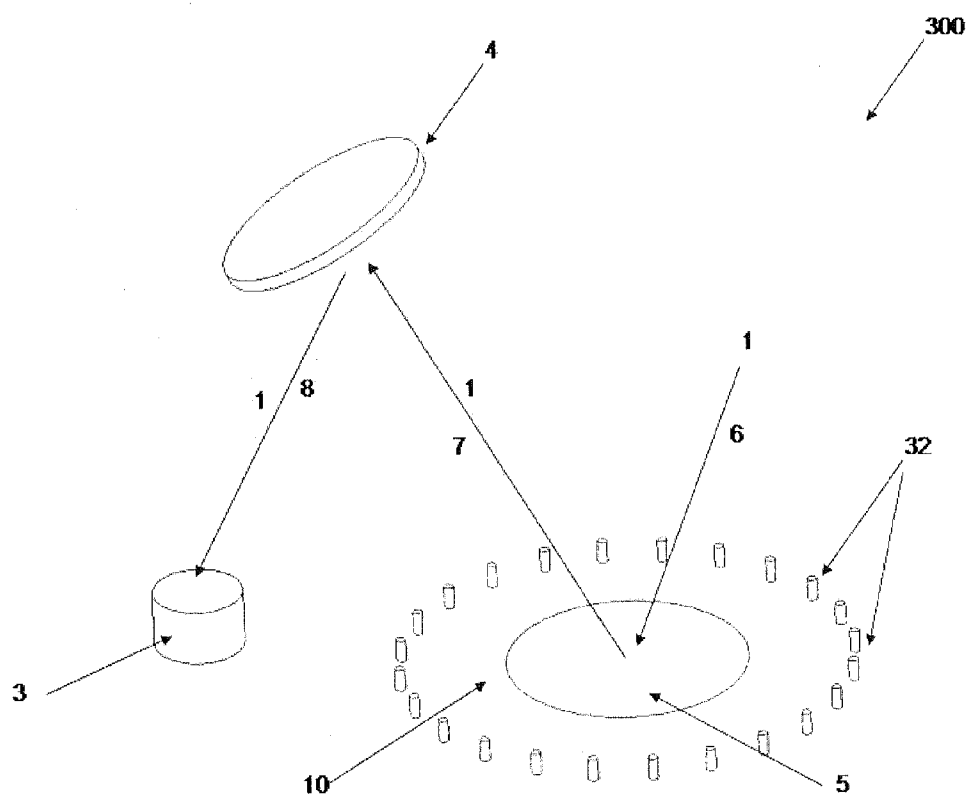

Fig. 2a

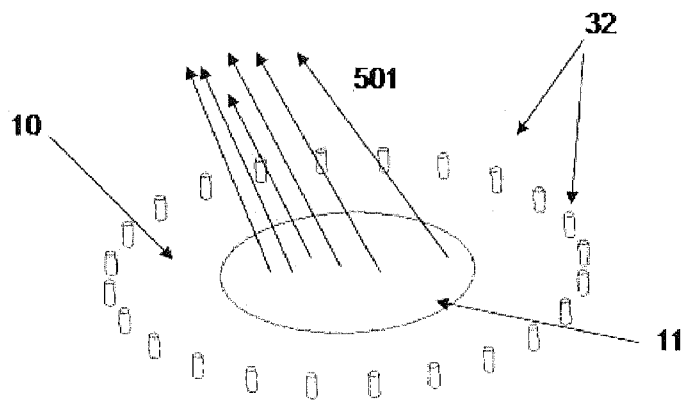
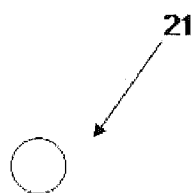

Fig. 2b

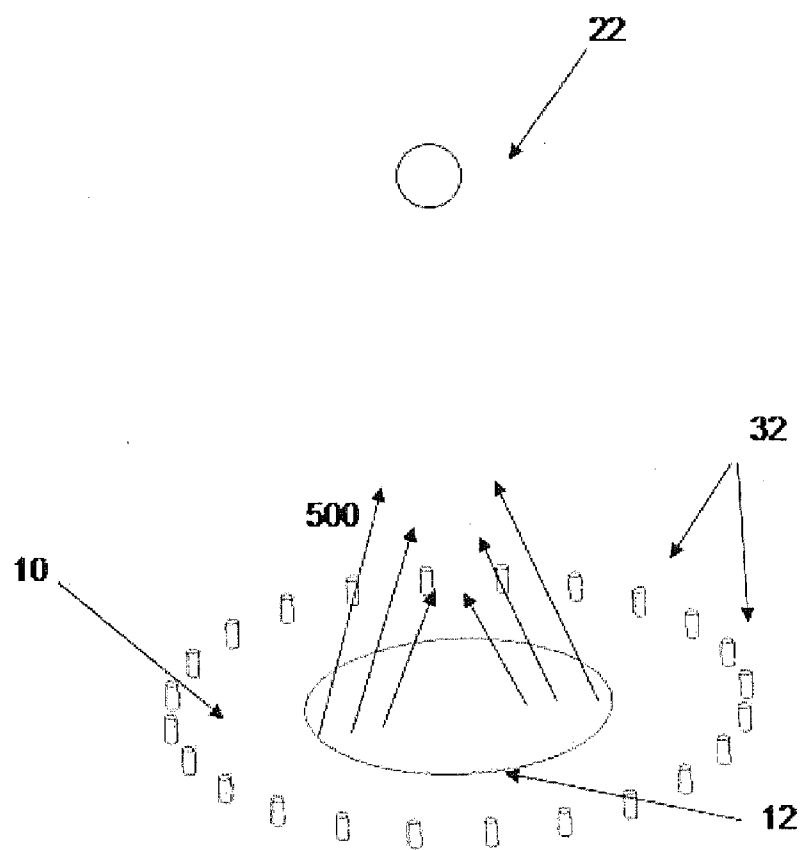
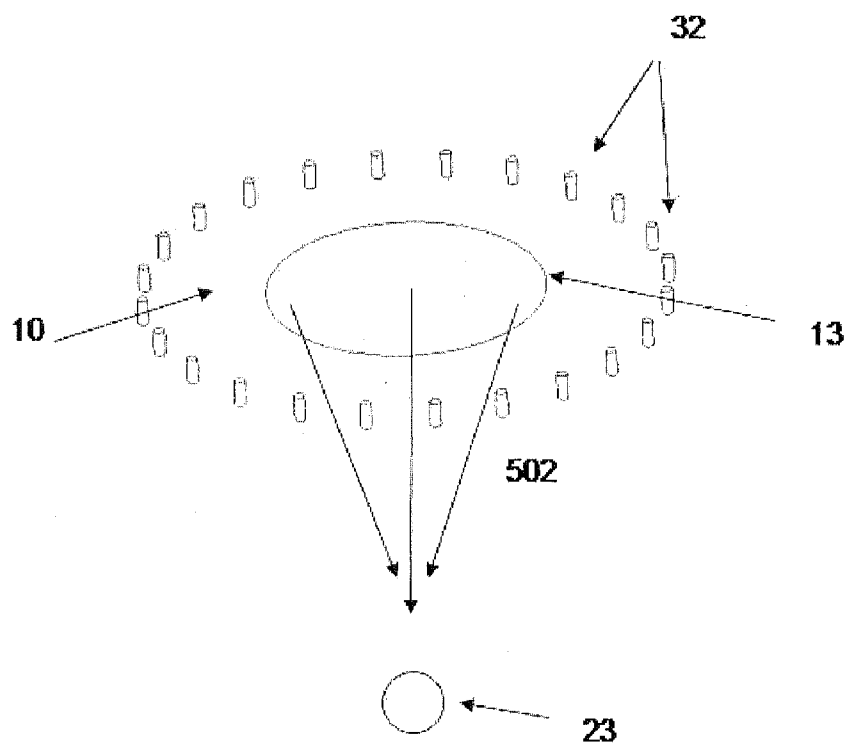

Fig. 2c



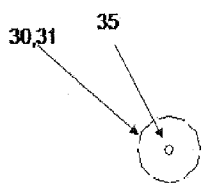

FIG. 3a

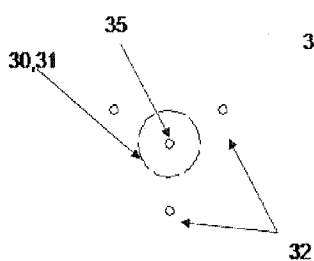

FIG. 3b

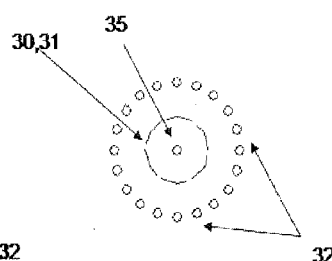

FIG. 3c

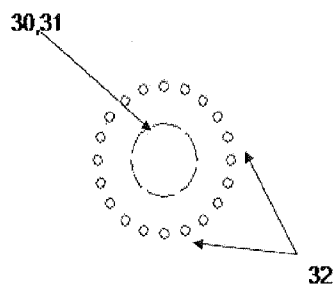

FIG. 3d

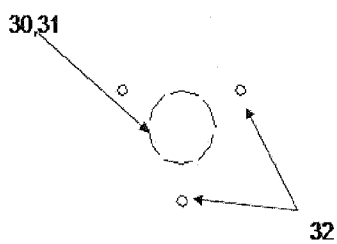

FIG. 3e

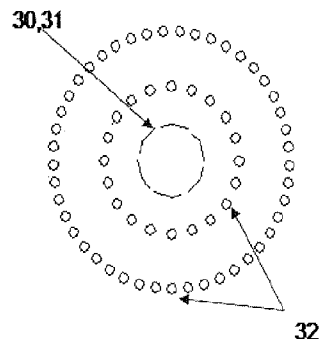

FIG. 3f

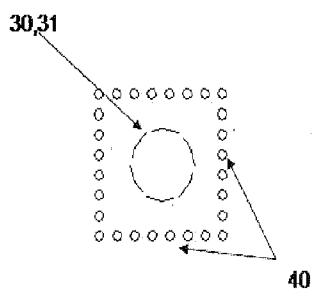

FIG. 3g

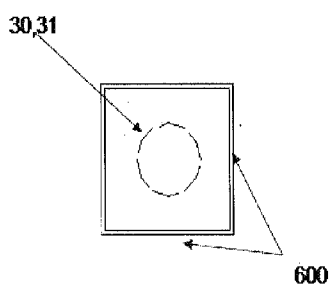

FIG. 3h

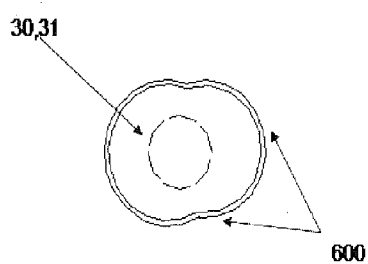

FIG. 3i

FIG. 3j

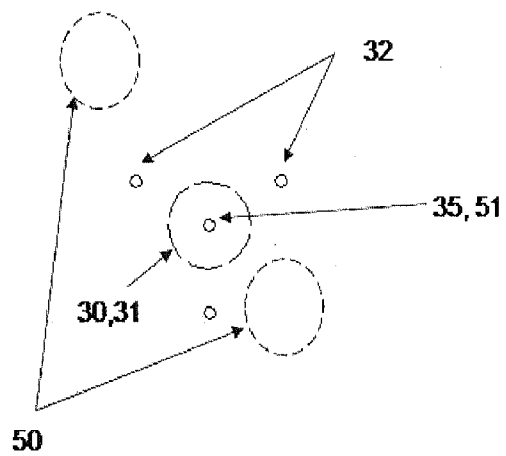

FIG. 4

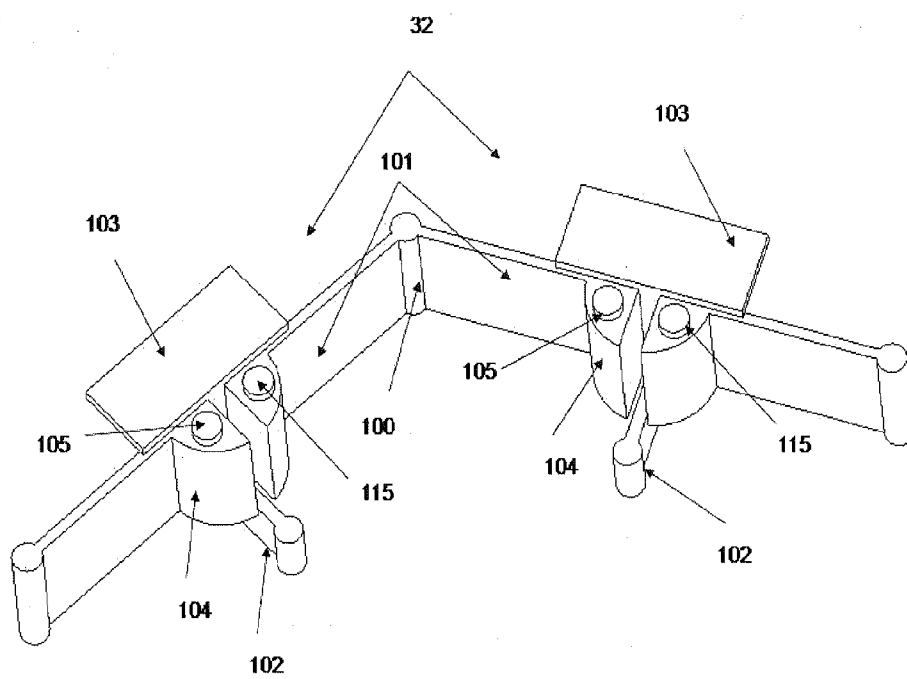

FIG. 5

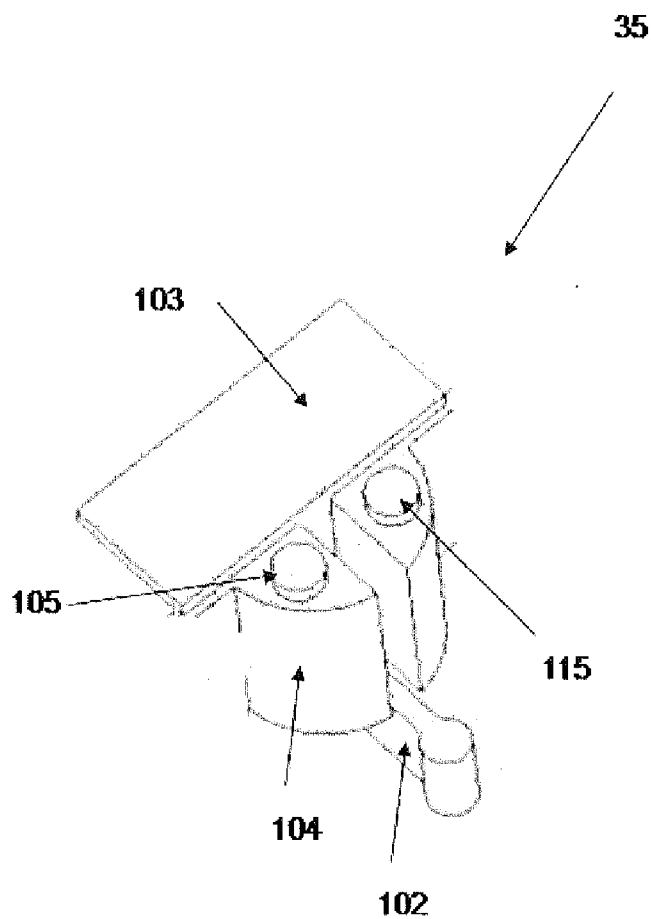
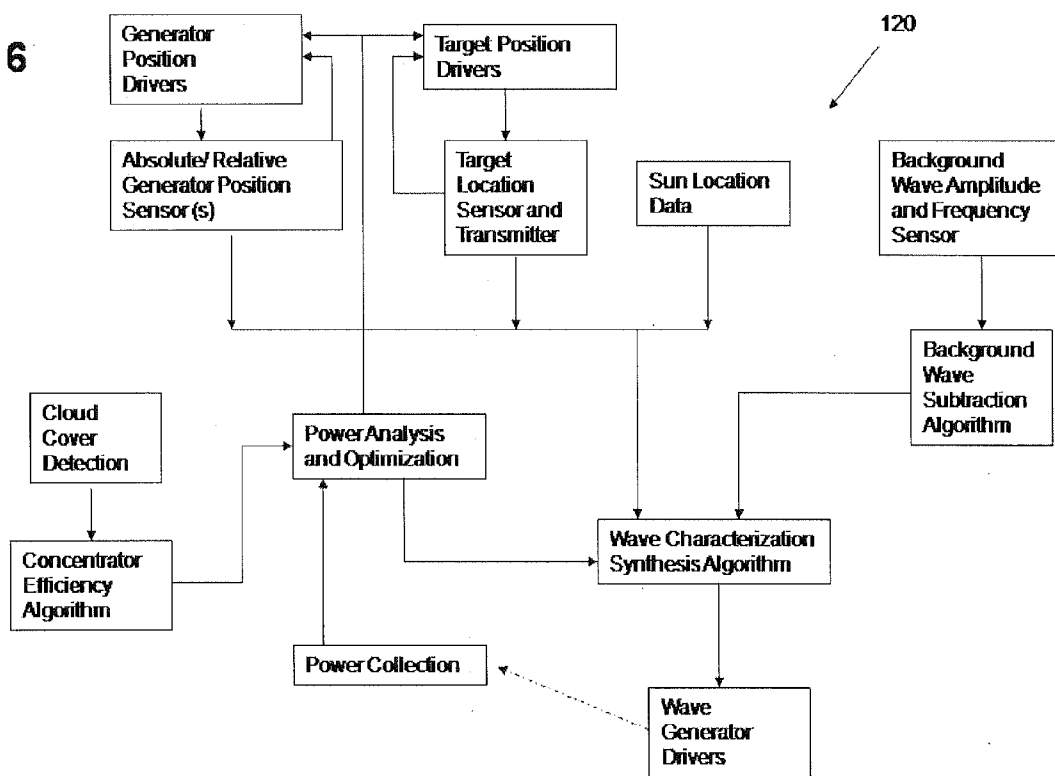

FIG. 6



**WAVE GENERATED ENERGY FOCUSING
LENS AND REFLECTOR FOR SOLAR
CONCENTRATION, COLLECTION, AND
HARNESSING**

[0001] The generation of solar energy has become a major focus of society in an attempt to relieve its dependence on oil, coal, and other fossil fuels. There are two primary methods for generating power from solar energy. The first involving radiating a photovoltaic solar panel to generate an electrical voltage, and second, concentrating solar energy onto a target which absorbs the energy as heat and then converting the heat to power (generally via steam). In both cases, the cost associated with the setup of the systems and the level of the power produced make the power expensive in comparison to alternatives such as coal burning power plants.

[0002] In considering concentrator (or concentration) systems, the use of mirrors is widely favored versus using lenses to concentrate solar energy. This is primarily due to the increased cost associated with forming a glass lens compared to using a sheet metal material to form the mirror. The high cost of concentrator systems is also attributable to the set-up and electromechanical tracking of the mirrors onto a fixed target. The target is generally a heat absorbing system which converts water to steam via heat transfer pipes and a steam turbine.

[0003] Gross et al., in U.S. Pat. Nos. 7,192,146 and 6,959,993 describe a heliostat array that is mechanically linked. Nohrig in U.S. Pat. No. 6,953,038 describes a mechanical frame as does Ven in U.S. Pat. No. 6,349,718. U.S. Pat. No. 7,568,479 by Rabinowitz discloses a Fresnel lens apparatus used for solar concentration and the associated mechanical systems. In attempting to make large collection areas, capable of generating significant commercial power levels, all these systems are inherently encumbered by the electromechanical systems required to move and adjust the mirrors onto a target area.

[0004] Researchers at the Akishima Laboratories in Japan and Professors Etsuro Okuyama and Shigero Haito at the University of Osaka have been able to use synchronized wave generators to create letters in standing pools of water.

OBJECTS OF INVENTION

[0005] It is therefore an object of the current invention to allow for the production of power on a large scale at low capital costs. Ideally, said system using a concentrating mirror array or lens array that does not require moving fixtures or framing to support the mirrors or lenses. It is further an object of the current invention to allow for controlled power generation on a large scale. It is further an object of the current invention to minimize the environmental impact of the power generation.

SUMMARY OF INVENTION

[0006] In summary, the following invention comprises forming a mirror or lens by creating a composite wave structure within a liquid medium formed by the interference pattern of waves created from one or more wave generators placed in contact with or in close proximity to the liquid. The wave generators may be outfitted with integrated or stand alone sensors to detect the background waves (i.e., waves due to wind effects) and the computer system controlling the wave

generator(s) to apply a wave to correct for the noise. The liquid medium may also have a top reflective coating upon which incident solar radiation reflects to achieve focusing upon a target. The target being located at a focal distance of the formed mirror or lens.

[0007] As an example, consider a 3,218 meter diameter ring that is formed using 33,158 coupled wave generators, each located along the circumference of the ring, each 0.3 meters wide, and the assembly placed within a standing body of water, such as a river, lake, or pool. The generators potentially being solar powered, each connected in series or in parallel and actuated with a timed electronic modulated driver so as to create a standing or moving wave which resembles a lens or mirror. Each wave generator may be further controlled directly through a cable or via an electromagnetic signal and a computer and further use feedback from various sensors including ambient wave height sensors. An aluminum powder or other reflective material may be spread over the liquid medium in order to increase the reflective strength of the created mirror. The mirror is dynamically created and moved such that the incident angle of the sun forms a reflected image on a focus point. The focus point may be located above or below the lens on a stationary, moving, floating, or hovering platform which further transforms the energy to another medium for electrical power generation or to a surface that provides a secondary reflective surface to transfer the energy. A single mirror of this size could reflect upwards of 1 giga watts of solar energy (at an average sun field density of 300 watts per square meter).

[0008] As another example, consider a 3 meter diameter ring that is fitted with 31 wave generators each 0.3 meters wide and placed within a standing body of water, such as a river, lake, ocean, or pool. Multiple rings may be arrayed so as to create a composite field of mirrors. A field of 500 mirrors, each capable of reflecting 1,000 watts of solar energy (at an average sun field density of 300 watts per square meter) consisting in total of 15,500 wave generators could provide 0.5 MW of reflected sun energy.

DRAWINGS

[0009] FIG. 1 is an isometric view of an example of a wave generator solar concentrator system.

[0010] FIGS. 2a, 2b, and 2c are isometric views of alternate wave generator solar concentrator systems and light reflection paths.

[0011] FIGS. 3a through 3j are schematics showing alternative placements of generators used for generating a wave formed lens in a solar concentrator system.

[0012] FIG. 4 is an isometric view of a multiple wave generator and the electronic controls.

[0013] FIG. 5 is an isometric view of a single wave generator and the electronic controls.

[0014] FIG. 6 is a schematic drawing illustrating the control system matrix and algorithms used to modulate the wave generator system.

DESCRIPTION OF DRAWINGS

[0015] FIG. 1 illustrates a wave concentration system 300 consisting of wave generators 32 activated to form a focusing or reflecting lens surface 5 within a liquid medium 10. The surface formed may act as a mirror or a lens, in a manner similar to conventional concave, or convex lenses and reflectors. The liquid medium may have a surfactant within it that

floats on the surface to increase the reflectance of the surface or the medium may include dissolved or partially dissolved solids or other components to improve the formed lens characteristics. Light beam 1, most generally coming from the sun coming from path 6, being reflected in a coherent manner by the generated wave surface 5 to a secondary reflector 4 via path 7. Reflector 4 being mounted to a stationary land based fixture or attached to a tethered system, or mounted above the generated wave surface through a floating, flying, or other self lifting system. Reflector 4 further passing light beam 1 to target 3 via path 8. Target 3 may be single or multiple solar cells to convert the light into electrical energy, or a heat absorbing unit such as a salt bath further used to convert water to steam and then electrical energy or other target for other use.

[0016] FIGS. 2a, 2b, and 2c illustrate various lenses or reflectors 11, 12, and 13 respectively created via wave generators 32. In FIG. 2a, the sun light 501 is reflected to target 21 located above and offset to the center of the surface of the liquid medium 10, while in FIG. 2b the sun light 500 is focused directly above to target 22. In FIG. 2c the sun light 502 is focused into the liquid medium to a target 23 located below the surface of the liquid medium. In FIGS. 2a, 2b, and 2c the respective targets 21, 22, and 23 may behave similarly to reflector 4 or target 3 of FIG. 1 or both.

[0017] FIGS. 3a, 3b, 3c, 3d, 3e, 3f, 3g, 3h, 3i, and 3j illustrate different configurations and placements of wave generators 32, 35, 40, and 600 used for creating the reflector or lens 30 in the area 31 and 50 (indicated by the dashed line). The optimization of the number of generators required can be modeled using computer systems and the ambient surface conditions and noise created by winds or by other objects passing nearby, such as boats, can be modeled as well to optimize the system.

[0018] FIGS. 3a, 3b, and 3c illustrate a lens or reflector 30 created using a central generator 35 as well as combined with additional generators 32 placed in a circular pattern around the central generator 35. In FIGS. 3d, 3e, and 3f, the central generator 35 is removed and single or multiple generators 32 are placed around the intended lens or reflector region 31. The algorithms used to create the waves constantly adjusting to account for the light source's position with respect to the lens and/or target(s) as well as any ambient wave noise or disturbance. In FIG. 3f, multiple rings of generators 32 are circumscribed and these may be located at different depths within the medium 10.

[0019] In FIGS. 3g, 3h, and 3i, the wave generators are placed in a non-circular fashion to form a lens or reflector in region 31. While FIG. 3g illustrates multiple independent wave generators 40 arranged in a square pattern, FIGS. 3h and 3i use continuous vibrating assemblies 600 such as piezo electric surfaces shaped as a square and combined circles respectively to form the lens or mirror in region 31. Such mixer systems further described by Berg and De Luca in Review of Scientific Instruments, Volume 62, Issue 2, February 1991, pp. 527-529, "Milliwatt Mixer for Small Fluid Samples." Assemblies 40 and 600 may be further used in conjunction with central generators 32.

[0020] In FIG. 3j the wave generators 32 and 35 form a central lens or reflective area 31 and may also form single or multiple lens or reflective areas 50 located off center to the primary central symmetry point 51.

[0021] FIG. 4 illustrates multiple wave generators 32 bound together at pivot 100 via arms 101 with angular encod-

ers. Each generator equipped with a primary actuation unit 102 that produces the waves; these waves being created through a single or multiple controlled motions which may include rotary, linear, impact, harmonic, or turbulent actuation. The energy required to create the motion may be fed directly through an external power supply, an internal power supply, or may comprise a renewable energy source such as the solar panels 103. Each generator 32 may also include a battery 104 to help power the unit including in case of low sun conditions and may also include GPS and sun tracking systems 105. The generators may also include equipment able to communicate local conditions such as ambient wave conditions, adjacent generator encoder value, absolute position, fluid temperature and velocity at port and antenna 115. Wave generator 32 may be combined with additional equipment such as flotation or translocation equipment.

[0022] FIG. 5 illustrates a single wave generator 35 equipped with a primary actuation unit 102 that produces the waves; these waves being created through a single or multiple controlled motions which may include rotary, linear, impact, harmonic, or turbulent actuation. The energy required to create the motion may be fed directly through an external power supply, an internal power supply, or may comprise a renewable energy source such as the solar panels 103. Each generator 35 may also include a battery 104 to help power the unit including in case of low sun conditions and may also include GPS and sun tracking systems 105. The generators may also include equipment able to communicate local conditions such as ambient wave conditions, adjacent generator encoder value, absolute position, fluid temperature and velocity input at port and antenna 115. Wave generator 35 may be combined with additional equipment such as flotation or translocation equipment.

[0023] FIG. 6 illustrates an electronic control circuit 120 used to control one or more wave generators in a complete system such as 300 shown in FIG. 1. At the onset, the sun position may be obtained using GPS or sensory information and combined with the information relating the generator position (s) and the target position (s); further communicated to a central computer for processing from the individual sensors located on each generator and the target. The wave generator algorithm will use the position information and combine this with sensory information obtained about the background noise to create driver information for each of the wave generators. Upon collection of the power at the target area, the energy obtained can be compared to baseline quantities and the reflective or lens characteristics can be optimized. The cloud cover may also be factored into the optimization algorithms and in some cases the generators may be shut down to prevent loss of energy due to insufficient energy generation. In addition, fluid additives used to optimize reflection or refraction may be controlled via the control system, and target and generator positions may be further altered based on optimization of energy collection.

[0024] Any and all publications and patent applications mentioned in this specification are indicative of the level of skill of those skilled in the art to which this invention pertains. All publications and patent applications mentioned herein are hereby incorporated by reference in their entirety to the same extent as if each individual publication or application was specifically and individually incorporated by reference.

[0025] It is to be understood that the invention is not to be limited to the exact configuration as illustrated and described herein. Accordingly, all expedient modifications readily

attainable by one of ordinary skill in the art from the disclosure set forth herein, or by routine experimentation therefrom, are deemed to be within the spirit and scope of the invention as defined by the appended claims.

What is claimed:

1. A solar energy concentration system comprising one or more wave generators actuated to create a reflector or lens that concentrates solar energy onto a target for use and/or storage.

2. The solar energy concentration system of claim 1, wherein the wave generators are placed in a liquid medium.

3. The solar energy concentration system of claim 2, wherein the liquid medium is water.

4. The solar energy concentration system of claim 1, wherein the target is a heat absorbent material.

5. The solar energy concentration system of claim 1, wherein the target is a reflective material.

6. The solar energy concentration system of claim 1, wherein the wave generators are driven using stored energy.

7. The solar energy concentration system of claim 1, wherein the wave generators are driven using renewable energy such as solar or wind energy.

8. A process for concentrating solar energy comprising:
activating one or more wave generators;
forming a lens or reflector within a medium excited by the wave generator(s);
focusing sunlight on a target by transmission through, or reflectance by, the lens or reflector to concentrate and collect solar energy; and
using, storing, or transmitting the collected solar energy.

* * * * *