



- (51) International Patent Classification:
F21S 8/10 (2006.01) F21V 17/02 (2006.01)
- (21) International Application Number:
PCT/US2012/048410
- (22) International Filing Date:
26 July 2012 (26.07.2012)
- (25) Filing Language: English
- (26) Publication Language: English
- (30) Priority Data:
61/511,835 26 July 2011 (26.07.2011) US
- (71) Applicant (for all designated States except US): **GO-LIGHT, INC.** [US/US]; 37146 Old Hwy 17, Culbertson, Nebraska 69024 (US).
- (72) Inventors; and
- (75) Inventors/Applicants (for US only): **GEBHARD, Albert** [US/US]; 2101 East Alameda Avenue, Denver, Colorado 80209 (US). **HOSICK, Colton D.** [US/US]; 37146 Old Hwy 17, Culbertson, Nebraska 69024 (US).
- (74) Agent: **SMITH, Abigail**; Oppedahl Patent Law Firm LLC, 12000 Pecos Street - suite 252, Westminster, Colorado 80234 (US).

(81) Designated States (unless otherwise indicated, for every kind of national protection available): AE, AG, AL, AM, AO, AT, AU, AZ, BA, BB, BG, BH, BN, BR, BW, BY, BZ, CA, CH, CL, CN, CO, CR, CU, CZ, DE, DK, DM, DO, DZ, EC, EE, EG, ES, FI, GB, GD, GE, GH, GM, GT, HN, HR, HU, ID, IL, IN, IS, JP, KE, KG, KM, KN, KP, KR, KZ, LA, LC, LK, LR, LS, LT, LU, LY, MA, MD, ME, MG, MK, MN, MW, MX, MY, MZ, NA, NG, NI, NO, NZ, OM, PE, PG, PH, PL, PT, QA, RO, RS, RU, RW, SC, SD, SE, SG, SK, SL, SM, ST, SV, SY, TH, TJ, TM, TN, TR, TT, TZ, UA, UG, US, UZ, VC, VN, ZA, ZM, ZW.

(84) Designated States (unless otherwise indicated, for every kind of regional protection available): ARIPO (BW, GH, GM, KE, LR, LS, MW, MZ, NA, RW, SD, SL, SZ, TZ, UG, ZM, ZW), Eurasian (AM, AZ, BY, KG, KZ, RU, TJ, TM), European (AL, AT, BE, BG, CH, CY, CZ, DE, DK, EE, ES, FI, FR, GB, GR, HR, HU, IE, IS, IT, LT, LU, LV, MC, MK, MT, NL, NO, PL, PT, RO, RS, SE, SI, SK, SM, TR), OAPI (BF, BJ, CF, CG, CI, CM, GA, GN, GQ, GW, ML, MR, NE, SN, TD, TG).

Published:
— without international search report and to be republished upon receipt of that report (Rule 48.2(g))

(54) Title: MULTI-FACE ROTATABLE HOUSING AND MOUNTING PLATFORM

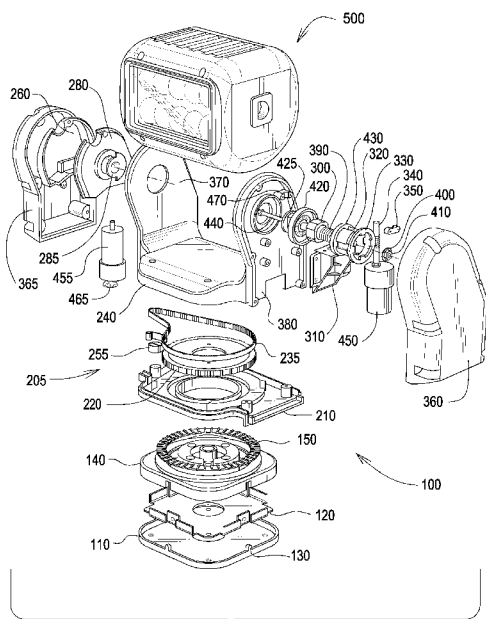

FIG.4

(57) Abstract: A two-faced rotatable housing and mounting platform is disclosed. The faces can include any combination of light-emitting diodes (LEDs), high-intensity discharge (HID) lamps, halogen lights, incandescent lights, or imaging devices, such as cameras. The depicted device can include a vertical tilt, which can be adjusted either manually or electronically. A slip ring system provides continuous 360 rotation ability. Speed of the continuous rotation can be controlled and adjusted. The unit contains an optional home position, allowing a user to select a point in the horizontal rotation to which the unit will return at the touch of a button.



TITLE

Multi-Face Rotatable Housing and Mounting Platform

CROSS REFERENCE APPLICATIONS

[0001] This application is a non-provisional application claiming the benefit of
5 provisional application no. 61/511,835 filed July 26, 2011, the disclosure of which is
hereby incorporated by reference for all purposes.

BACKGROUND

[0002] Rotatable lights, pan and tilt assemblies, and mounting systems are known in the
art. Existing systems are limited, however, to single-use applications. Stated differently,
10 each housing could only accommodate a single device, such as a light or camera.
Interchangeability of these devices is not possible in prior art systems. Further,
continuous horizontal rotation is not provided, nor does a user have the ability to select
the speed at which horizontal rotation occurs. Units which provide vertical tilt and
rotation do not allow manual manipulation to adjust the vertical angle or rotate the unit
15 without causing potential harm to the unit and its drive systems.

[0003] The foregoing example of the related art and limitations related therewith are
intended to be illustrative and not exclusive. Other limitations of the related art will
become apparent to those of skill in the art upon a reading of the specification and a study
of the drawings.

20

SUMMARY

[0004] The following embodiments and aspects thereof are described and illustrated in
conjunction with systems, tool and methods which are meant to be exemplary and
illustrative, not limiting in scope. In various embodiments, one or more of the above
described problems have been reduced or eliminated, while other embodiments are
25 directed to other improvements.

[0005] The disclosed device is designed to simultaneously accommodate two systems. Selected systems can include any combination of light-emitting diodes (LEDs), high-intensity discharge (HID) lamps, halogen lights, cameras or infra red or heat sensitive devices. Optionally, a powered vertical tilt may be included which can be manually
5 adjusted without harm to the unit. A continuous 360° rotation ability is provided in addition to a limited stop to stop capability. A user has the ability to select a speed for the rotation, in addition to selecting a home position, to which the unit will return at the touch of a button.

[0006] The disclosed device has a simple and weather proof design, which allows for
10 easy assembly and maintenance. A device according to the present disclosure provides improved durability and weather resistance.

[0007] A rotatable mounting system is disclosed. The mounting system comprises a base gasket, a base plate mounted on said base gasket, a base mounted on said base plate, a bearing rotatably mounted on said base, a lower yoke mounted over said bearing, a
15 horizontal gear rotatably mounted to said lower yoke, an upper yoke mounted over said horizontal gear. The upper yoke comprises a first arm and a second arm. The first arm comprises a horizontal motor. The second arm comprises a vertical tilt motor. A housing means is also disclosed. The housing means is pivotally connected to the first arm and the second arm. Means for the horizontal motor to turn said horizontal gear and means
20 for the vertical motor to tilt the housing means vertically are also disclosed.

[0008] The disclosed housing comprises a heat sink. The heat sink has a first side and a second side. A first optical mean is attached to the first side of the heat sink. A second optical means is attached to the second side of the heat sink. The housing has a top and a bottom. A top cap covers the top of the housing and a bottom cap covers the bottom of
25 the housing.

[0009] In addition to the exemplary aspects and embodiments described above, further aspects and embodiments will become apparent by reference to the accompanying drawings forming a part of this specification wherein like reference characters designate corresponding parts in the several views.

5

BRIEF DESCRIPTION OF THE DRAWINGS

[0010] Before explaining the disclosed embodiment of the present invention in detail, it is to be understood that the invention is not limited in its application to the details of the particular arrangement shown, since the invention is capable of other embodiments.

Exemplary embodiments are illustrated in referenced figures of the drawings. It is intended that the embodiments and figures disclosed herein are to be considered illustrative rather than limiting. Also, the terminology used herein is for the purpose of description and not of limitation.

15 [0012] Figure 2 is an exploded view of the yoke assembly of the platform of Figure 1.

[0013] Figure 3 is a front perspective view of the partially assembled yoke assembly of a second embodiment of the rotating/tilting platform and mounting system of the present application.

[0014] Figure 4 is an exploded view of Figure 3.

20 [0015] Figure 5 is a bottom plan view of the yoke assembly of Figure 3.

[0016] Figure 6 is a perspective view of the yoke of Figures 2 and 3.

[0017] Figure 7 is a front view of Figure 6.

[0018] Figure 8 is an exploded view of the worm gear tilt assembly of Figures 2 and 3.

[0019] Figure 9 is an assembled view of the worm gear assembly Figures 2 and 3.

[0020] Figure 10 is an exploded view of the lamp housing assembly of Figures 1 and 4.

DETAILED DESCRIPTION OF THE DRAWINGS

[0021] Turning first to Figure 1, an exploded view of the base assembly 100 is shown. A
5 base plate 120 rests on a gasket 110. In use, base plate is permanently attached to a
vehicle by four screws (not shown). The unit is then hardwired to the vehicle and
operated using a joystick (not shown). A radio receiver and transmitter is an alternate
method of communicating with the unit. While screws are described, one having an
ordinary level of skill in the art will understand that alternate fasteners could be used and
10 still be within the scope of the disclosure. Gasket 110 includes flaps 130 which cover the
screws (not shown) that retain the entire assembly to the base plate after assembly. In the
depicted embodiment, gasket 110 comprises rubber. One having an ordinary level of
skill in the art will understand that other materials having similar properties to rubber
could be substituted. The entire assembled device is attached or removed easily by use of
15 the four lateral screws into the base plate 120. A base 140 is mounted on top of base
plate 120. In the depicted embodiment, base 140 comprises carbon fiber filled plastic. In
the depicted embodiment, the plastic is acrylonitrile butadiene styrene (ABS). One
skilled in the art will understand that other materials having similar strength and
durability to carbon fiber filled plastic could be substituted and still be within the scope
20 of the disclosure. A unique wiper bearing 150 is mounted on base 140. In use, wiper
bearing 150 wipes the bearing surface clean as it rotates. Because of its unique design,
the bearing cleans both bearing surfaces and maintains proper compression between the
base 140 and the entire upper assembly beginning with the lower yoke 210. In the
depicted embodiment, wiper bearing 150 comprises a very high molecular weight
25 polyethylene. One having an ordinary level of skill in the art will understand that other
materials having similar properties to polyethylene are contemplated by this disclosure.

[0022] Figure 1 depicts a first embodiment of a yoke assembly 200. In yoke assembly 200, lower yoke 210 sits on top of wiper bearing 150. Horizontal gear 220 is attached to lower yoke 210 by four screws (not shown). While screws are depicted, one having ordinary skill in the art will understand that alternate fasteners could be used and still be within the scope of the present disclosure. Lower yoke 210 and wiper bearing 150 are compressed and held together by the four screws holding down horizontal gear 220. Idler gear 230 is mounted adjacent to horizontal gear 220. Horizontal motor and gear box 250 is mounted in upper yoke 240 in motor mount 245 (not visible in Figure 1). Electronics, speed control and radio receiver are located inside the enclosure formed by housing outer shell 260, housing inner shell 280 and fixed pivot (not shown). Upper yoke 240 engages with base 140 to enclose all the parts in between. Housing assembly 500 mounts in upper yoke 240.

[0023] In use, the entire assembly rotates around horizontal gear 220. Power is supplied from horizontal motor 250 to idler gear 230, which engages horizontal gear 220, thereby rotating the entire yoke assembly 200, including housing assembly 500. In the depicted embodiment, yoke assembly 200 rotates 360° continuously. The continuous horizontal rotation of the yoke assembly 200 rotates the two optical means in the housing assembly 500 horizontally in a continuous circle, allowing the user to point either optical mean in any given horizontal direction. The depicted embodiment includes an optional speed feature, which allows a user to select the speed of the rotation. A slip ring (not shown) with two wires (not shown) on each side allows for continuous rotation. In the depicted embodiment, fixed pivot (not shown) can house radio control or a home position electronic component, for example. Opposite this there is a “live” pivot (depicted in Figure 2) that drives the tilt of housing assembly 500. A home position electronic component would allow a user to select a position in the horizontal rotation of yoke assembly 200 and program the unit to return the yoke assembly 200 to the selected position at the push of a button.

[0024] Turning next to Figure 2, an exploded view of yoke assembly 200 is shown. Yoke assembly 200 provides pan and tilt ability for the housing assembly 500. In the depicted embodiment, the tilt pivot is integrated with the box that holds the electronics. Upper yoke 240 has two arms 370, 380. A first arm 370 includes housing inner shell 280
5 and housing outer shell 260. Housing inner shell 280 includes fixed pivot 285.

[0025] Vertical gear profile 290 mounts in second arm 380. Vertical gear profile 290 includes protrusion 420 and shaft 425. A screw 440 is inserted through protrusion 420. A vertical gear clutch disk 300 mounts on protrusion 420. Spring 390 is mounted on protrusion 420, immediately adjacent to vertical gear clutch disk 300. In use, spring 390
10 holds the clutch in an engaged condition. Vertical gear base 320 then mounts onto protrusion 420, covering vertical gear clutch disk 300 and spring 390. Vertical gear base 320 has a lip 430. A vertical gear 330 is mounted over vertical gear base 320 and rests on lip 430. A washer 400 and nut 410 are then placed on screw 440, capturing the intervening parts. While a screw, nut and washer are depicted as the method for
15 attaching the foregoing parts to second arm 380, one skilled in the art would understand that other methods could be used and still be within the scope of the disclosure.

[0026] A vertical motor cradle 310 is attached to second arm 380 adjacent to vertical gear profile 290. Vertical motor cradle 310 includes void 460. A vertical tilt motor 450 is attached to vertical motor cradle 310. Vertical tilt motor 450 includes worm 340, which
20 protrudes through void 460. In the depicted embodiment, worm 340 is a single thread worm. While a single thread worm is depicted, multi-thread worms could be used and still be within the present disclosure. A worm saddle cap 350 attaches worm 340 to second arm 380 via projection 470. First arm cover 360 supports moving aspects of tilt device and encloses the components in yoke assembly 200.

[0027] In use, worm 340 engages vertical gear 330. When vertical tilt motor 450 causes worm 340 to rotate, vertical gear 330 also rotates, causing housing assembly 500 to tilt vertically. Vertical gear clutch disk 300 allows manual movement of housing assembly

500 up and down without harm. The depicted embodiment allows both faces, optical means, of housing assembly 500 to rotate vertically in an approximately 135 degree arc from 45 degrees+ down from horizontal to 0 degrees (straight up) and any position in between. The combination of the continuous horizontal rotation and the large arc of vertical rotation allows a user to direct either optical means to just about any direction around the vehicle or other device the light is mounted on to see a desired object. The only areas the optical means could not be pointed towards are highly likely to be the body of the vehicle the optical system is mounted on. This eliminates potential “blind spots” of some of the prior art devices where a user could not point the optical means in a chosen line of sight direction without turning the vehicle.

[0028] Turning next to Figure 3, an alternate yoke assembly 205 is shown. In this embodiment, base assembly 100 remains the same as that disclosed in Figure 1. Base plate 120 rests on a gasket 110. Gasket 110 includes flaps 130 which cover the screws used to attach the base to the base. A base 140 is mounted on top of base plate 120. A wiper bearing 150 is mounted on base 140. In use, wiper bearing 150 wipes the bearing surface clean as it rotates. Because of its unique design, the bearing cleans both bearing surfaces and maintains proper compression between the base 140 and the entire upper assembly beginning with the lower yoke 210.

[0029] In use, base plate 120 is permanently attached to a vehicle by four screws (not shown). While screws are described, one having an ordinary level of skill in the art will understand that alternate fasteners could be used and still be within the scope of the disclosure. The entire assembled device is attached or removed easily by use of the four lateral screws into the base plate 120. The unit is then hardwired to the vehicle and operated using a joystick (not shown). Alternatively, a radio receiver and transmitter can be used to communicate with the unit. In the depicted embodiment, gasket 110 comprises rubber. One having an ordinary level of skill in the art will understand that other materials having similar properties to rubber could be substituted. In the depicted embodiment, base 140 comprises carbon fiber filled plastic. In the depicted embodiment,

the plastic is acrylonitrile butadiene styrene (ABS). One skilled in the art will understand that other materials having similar strength and durability to carbon fiber filled plastic could be substituted and still be within the scope of the disclosure. In the depicted embodiment, wiper bearing 150 comprises a very high molecular weight polyethylene.

5 One having an ordinary level of skill in the art will understand that other materials having similar properties to polyethylene are contemplated by this disclosure.

[0030] Yoke assembly 205 comprises a lower yoke 210, which sits on top of wiper bearing 150. Horizontal gear 220 is attached to lower yoke 210 by four screws (not shown). While screws are depicted, one having ordinary skill in the art will understand that alternate fasteners could be used within the scope of the present disclosure. Lower yoke 210 and wiper bearing 150 are compressed and held together by the four screws holding down horizontal gear 220. Belt 235 is mounted over horizontal gear 220. A belt tensioner 255 is mounted on lower yoke 210 adjacent to horizontal gear 220 and belt 235. A horizontal motor 455 with an integral sprocket 465 is mounted in upper yoke 240 in contact with housing inner shell 280 and housing outer shell 260. Electronics, speed control and radio receiver are located inside the enclosure formed by housing outer shell 260, housing inner shell 280 and fixed pivot 285. Second arm cover 365 encloses housing outer shell 260, housing inner shell 280 and fixed pivot 285 in yoke assembly 200. Upper yoke 240 engages with base 140 to enclose all the parts in between. Housing assembly 500 mounts in upper yoke 240.

[0031] In use, the entire assembly rotates around horizontal gear 220. Power is supplied from horizontal motor 455 to belt 235 through sprocket 465. Belt 235 engages horizontal gear 220, thereby rotating the entire yoke assembly 205, including housing assembly 500. Belt tensioner 255 maintains proper tension on belt 235 as it transfers power from horizontal motor 455 to horizontal gear 220 and prevents belt slippage.

[0032] In the depicted embodiment, horizontal motor 455 is either a 12v DC or 24v DC motor and sprocket 465 is a 16 groove sprocket. In the depicted embodiment, belt 235 is

a 3 millimeter pitch, 0.24 inch wide HTD belt. In the depicted embodiment, horizontal gear 220 is a 120 groove gear. One having an ordinary level of skill will understand that other components having similar properties to those specifically described could be used and still be within the scope of the present disclosure. In use, the grooves on belt 235
5 interact with the grooves on horizontal gear 220. This interaction provides a more uniform distribution of shear stresses within the teeth and a transition of tooth loads to the tensile members in the belt. The addition of belt tensioner 255 ensures that belt 235 is correctly tensioned, which prevents slippage and allows belt 235 to run at constant speed. Optionally, a clutch device may be added on the end of horizontal motor 455.

10 [0033] In the depicted embodiment, yoke assembly 205 can rotate 360° continuously. The depicted embodiment includes an optional speed feature, which allows a user to select the speed of the rotation. A set screw (not shown) in base 140 holds a slip ring (not shown) with two wires (not shown) on each side. In the depicted embodiment, horizontal motor 455 has a fixed pivot 285. Fixed pivot 285 can house radio control or a home
15 position electronic component, for example. A home position electronic component would allow a user to select a position in the horizontal rotation of yoke assembly 200 and program the unit to return the yoke assembly 200 to the selected position at the push of a button. Fixed pivot 285 is part of a water tight enclosure.

[0034] Figure 3 shows a partially assembled yoke assembly 205 according to the present
20 disclosure. This perspective clearly shows the interaction between sprocket 465 of horizontal motor 455 and belt 235. The location of belt tensioner 255 on lower yoke 210 is shown, as well as its relation to belt 235. The attachment of vertical tilt motor 450 to lower yoke 210. The assembled vertical gear profile 290, vertical gear 330 and vertical gear base 320 interact with worm 340, which is mounted in vertical tilt motor 450
25 through vertical motor cradle 310. One skilled in the art will understand that the depicted arrangement of the components is not the only possible arrangement.

[0035] Figure 4 also depicts the portion of yoke assembly 205 which provides pan and tilt for the housing assembly 500. In the depicted embodiment, the tilt pivot is integrated with the box that holds the electronics. Upper yoke 240 has two arms 370, 380. A first arm 370 includes housing inner shell 280 and housing outer shell 260. Housing inner
5 shell 280 includes fixed pivot 285.

[0036] Vertical gear profile 290 mounts in second arm 380. Vertical gear profile 290 includes protrusion 420 and shaft 425. A screw 440 is inserted through protrusion 420. A vertical gear clutch disk 300 mounts on protrusion 420. Spring 390 is mounted on protrusion 420, immediately adjacent to vertical gear clutch disk 300. In use, spring 390
10 holds the clutch in an engaged condition. Vertical gear base 320 then mounts onto protrusion 420, covering vertical gear clutch disk 300 and spring 390. Vertical gear base 320 has a lip 430. A vertical gear 330 is mounted over vertical gear base 320 and rests on lip 430. A washer 400 and nut 410 are then placed on screw 440, capturing the intervening parts. While a screw, nut and washer are depicted as the method for
15 attaching the foregoing parts to second arm 380, one skilled in the art would understand that other methods could be used and still be within the scope of the disclosure.

[0037] A vertical motor cradle 310 is attached to second arm 380 adjacent to vertical gear profile 290. Vertical motor cradle 310 includes void (not visible). A vertical tilt motor 450 is attached to vertical motor cradle 310. Vertical tilt motor 450 includes worm 340,
20 which protrudes through void 460. In the depicted embodiment, worm 340 is a single thread worm. While a single thread worm is depicted, multi-thread worms could be used and still be within the present disclosure. A worm saddle cap 350 attaches worm 340 to second arm 380 via projection 470. First arm cover 360 supports moving aspects of tilt device and encloses the components in yoke assembly 200.

[0038] In use, worm 340 engages vertical gear 330. When vertical tilt motor 450 causes worm 340 to rotate, vertical gear 330 also rotates, causing housing assembly 500 to tilt vertically. Vertical gear clutch disk 300 allows manual movement of housing assembly

500 up and down without harm. The depicted embodiment allows both faces of housing assembly 500 to tilt from 45 degrees+ down to 0 degrees (straight up) and any position in between.

[0039] Figure 5 is a bottom plan view of yoke assembly 205. This view shows the arrangement of horizontal gear 220, belt 235, socket 465 and belt tensioner 255. As previously noted, the depicted arrangement is one of multiple possible arrangements, and the present disclosure is not limited to the depicted embodiment.

[0040] Figures 6-9 provide additional views which clarify the interaction of the components.

[0041] Turning next to Figure 10, an exploded view of housing assembly 500 is shown. A first housing 510 includes an integrated heat sink 520 comprising fins 525. The design of fins 525 is based on specific heat dissipation requirements of the LED array under specified conditions. There is also accommodation for fan to force the natural convection when ambient temperature is extreme. In the depicted embodiment, first housing 510 comprises aluminum with either a powder coat or painted finish. One having an ordinary level of skill in the art will understand that other materials having similar properties to aluminum could be used. A set of light-emitting diodes (LEDs) 530 is mounted on one side of first housing 510. In the depicted embodiment, 10 LEDs are shown. A person having an ordinary level of skill in the art will understand that the number of LEDs is variable. In the depicted embodiment, LEDs 530 are mounted in metal core printed circuit board (MCPCB) 540. While MCPCB is depicted, one having an ordinary level of skill in the art will understand that other materials with similar properties could be substituted. In the depicted embodiment, the LEDs are Luxeon star LEDs. A person having ordinary skill in the art will understand that other brands and types of LEDs could be substituted for Luxeon LEDs. A lens 550 is mounted over LEDs 530. In the depicted embodiment, lens 550 is a multiple plano convex type optic used as a super projector that collects then combines the output of the multiple LEDs into a single spotlight beam.

Lens 550 includes tabs 560, which interact with first housing 510 to hold lens 550 in place. In the depicted embodiment, lens 550 is made of acrylic, and is molded as a single piece. LEDs 530 are joined to first housing 510 with a silicone pad. Silicone provides excellent heat transfer to assist in the convection cooling of LEDs 530. Those having an ordinary level of skill in the art will understand that other materials having similar properties to silicone could be used, and that multiple lenses could be manufactured and later attached to one another or to the MCPCB. An outer protective acrylic lens cover 570 mounts over lens 550. A first bezel 580 mounts over lens cover 570. First bezel 580 attaches to first housing 510 by inserting screws (not shown) through voids 590 in first bezel 580, lens cover 570, and finally voids 600 in first housing 510, thereby enclosing all intervening parts. While the depicted embodiment uses screws to attach first bezel 580 and lens cover 570 to first housing 510, other means of attachment known to those having an ordinary level of skill in the art could be used.

[0042] Turning to the side of first housing 510 opposite LEDs 530, a first notch 610 is provided. First notch 610 is sized to accept a complimentary-shaped bearing 620. An opposing bearing 620 mounts in a second notch 630 in second housing 640. Another set of bearings 625 is mounted on the opposite side of first housing 510 and second housing 640. In the depicted embodiment, bearings 620 have a flat portion and bearings 625 do not have a flat portion. When first housing 510 and second housing 640 are attached, bearing 620 interacts with fixed pivot 285 and vertical gear profile 290 in yoke assembly 200 to allow housing assembly 500 to tilt vertically. In use, the flat portion of bearings 620 allows the tilt force to be transferred to the assembly.

[0043] A halogen lamp 650 is mounted in second housing 640. A second bezel 660 is mounted over halogen lamp 650 using screws (not shown), which pass through voids 670 in second bezel 660 and voids 680 in second housing 640. Once both faces of first housing 510 and second housing 640 are assembled, using 4 screws, a top cap 690 and bottom cap 700 are added to housing assembly 500 to close housings 510 and 640 together. Top cap 690 and bottom cap 700 include openings 710. Opening 710 allow air

to enter housing assembly 500. Air enters openings 710 in bottom cap 700 and travels over fins 525 of heat sink 520, and exits through openings 710 in top cap 690, allowing for convection and air cooling.

[0044] In one embodiment, an infrared filter is incorporated into second bezel 660. In this embodiment second bezel 660 is also composed of infrared material. In this embodiment, the infrared filter and second bezel are molded as one piece. In the depicted embodiment, first housing 510 houses LEDs and second housing 640 houses a halogen lamp 650. However, housing assembly 500 is not limited to this configuration. First housing and second housing could hold any combination of LEDs, halogen lights, cameras and/or high-intensity discharge (HID) lamps.

[0045] The entire assembly is water tight. The depicted unit, once assembled, has an Ingress Protection rating, or IP code, of IP 65 or better, meaning that the unit is totally protected against dust and protected against low pressure water jets from any direction; limited water ingress is permitted. Water proof connectors protect against any water that does enter the unit. The depicted unit can be produced to be as a 24v DC unit or as a 12v DC unit. The depicted unit is MIL-STD-461F compliant.

[0046] While a number of exemplary aspects and embodiments have been discussed above, those of skill in the art will recognize certain modifications, permutations, additions and sub-combinations therefore. It is therefore intended that the following appended claims hereinafter introduced are interpreted to include all such modifications, permutations, additions and sub-combinations are within their true spirit and scope. Each apparatus embodiment described herein has numerous equivalents.

[0047] The terms and expressions which have been employed are used as terms of description and not of limitation, and there is no intention in the use of such terms and expressions of excluding any equivalents of the features shown and described or portions thereof, but it is recognized that various modifications are possible within the scope of

the invention claimed. Thus, it should be understood that although the present invention has been specifically disclosed by preferred embodiments and optional features, modification and variation of the concepts herein disclosed may be resorted to by those skilled in the art, and that such modifications and variations are considered to be within
5 the scope of this invention as defined by the appended claims. Whenever a range is given in the specification, all intermediate ranges and subranges, as well as all individual values included in the ranges given are intended to be included in the disclosure. When a Markush group or other grouping is used herein, all individual members of the group and all combinations and subcombinations possible of the group are intended to be
10 individually included in the disclosure.

[0048] In general the terms and phrases used herein have their art-recognized meaning, which can be found by reference to standard texts, journal references and contexts known to those skilled in the art. The above definitions are provided to clarify their specific use in the context of the invention.

15 [0049] All patents and publications mentioned in the specification are indicative of the levels of skill of those skilled in the art to which the invention pertains. All references cited herein are hereby incorporated by reference to the extent that there is no inconsistency with the disclosure of this specification. Some references provided herein are incorporated by reference herein to provide details concerning additional starting
20 materials, additional methods of synthesis, additional methods of analysis and additional uses of the invention.

I CLAIM:

1. A rotatable mounting system for an optical device for mounting on a vehicle comprising:
 - a base gasket;
 - 5 a base plate mounted on said base gasket;
 - a base mounted on said base plate;
 - a bearing rotatably mounted on said base;
 - a lower yoke mounted over said bearing;
 - a horizontal gear rotatably mounted to said lower yoke;
 - 10 an upper yoke mounted over said horizontal gear;
 - said upper yoke comprising a first arm and a second arm;
 - said first arm comprising a horizontal motor;
 - said second arm comprising a vertical tilt motor;
 - 15 an optical device housing;
 - said optical device housing pivotally connected to said first arm and said second arm;
 - means for said horizontal motor to turn said horizontal gear in a continuous 360 degree motion; and
 - means for said vertical motor to tilt said housing vertically through an arc of about
 - 20 135 degrees.
2. The rotatable mounting system of claim 1, wherein said means for said vertical motor to tilt said housing comprises:
 - a vertical gear; and
 - a worm;
 - 25 wherein said worm is connected to said vertical motor; and
 - wherein said worm interacts with said vertical gear.
3. The rotatable mounting system of claim 2, further comprising a vertical motor cradle.

4. The rotatable mounting system of any of claims 1 to 3, wherein:
said means for said vertical motor to tilt said housing means vertically further
comprises a vertical gear clutch disk; and
wherein said vertical gear clutch disk allows the housing to be manually adjusted.
- 5 5. The rotatable mounting system of one of claims 1 to 4, wherein said means for
said horizontal motor to turn said horizontal gear comprises:
said horizontal motor further comprises a pinion;
said pinion contacts an idler gear;
said idle gear interacts with said horizontal gear to turn said horizontal gear;
10 wherein the turning of said horizontal gear causes said mounting system to rotate
horizontally.
6. The rotatable mounting system of one of claims 1 to 4, wherein said means for
said horizontal motor to turn said horizontal gear comprises:
said horizontal motor further comprises a groove sprocket;
15 a belt rests on said horizontal gear; and
said sprocket interacts with said belt to turn said horizontal gear;
wherein the turning of said horizontal gear causes said mounting system to rotate
horizontally.
7. The rotatable mounting system of one of claims 1 to 6, wherein said bearing
20 further comprises;
a wiper bearing; and
wherein said wiper bearing wipes the bearing surface clean as it rotates.
8. The rotatable mounting system of one of claims 1 to 7, wherein said base gasket
further comprises flaps.
- 25 9. The rotatable mounting system of one of claims 1 to 8, wherein said optical
device housing comprises:
a heat sink;
said heat sink having a first side and a second side;
a first optical device attached to said first side of said heat sink; and

- a second optical device attached to said second side of said heat sink.
10. The rotatable mounting system of one of claims 1 to 9, wherein said first optical device comprises:
- 5 a length of printed circuit board mounted to said first side of said heat sink;
at least one light-emitting diode mounted to said printed circuit board;
a lens mounted over said printed circuit board;
a first bezel connecting said projection lens and said printed circuit board to said first side of said heat sink;
said optical device having a top and a bottom;
10 a top cap covering said top of said optical device; and
a bottom cap covering said bottom of said optical device.
11. The rotatable mounting system of one of claims 1 to 10, wherein said second optical device comprises:
- 15 a halogen lamp housing;
a halogen lamp; and
a second bezel connecting said halogen lamp housing and said halogen lamp to said second side of said heat sink.
12. The rotatable mounting system of one of claims 1 to 9, wherein said first optical device is selected from the group consisting of light-emitting diodes, high-
20 intensity discharge lamps, halogen lights, cameras, infra red devices and heat sensitive devices.
13. The rotatable mounting system of one of claims 1 to 9, wherein said second optical device is selected from the group consisting of light-emitting diodes, high-
25 intensity discharge lamps, halogen lights, cameras, infra red devices and heat sensitive devices.
14. The rotatable mounting system of one of claims 1 to 13 further comprising:
a home button;
wherein a user selects a point in the horizontal rotation to which the unit will return at the touch of a button.

15. An optical device housing comprising:
a heat sink;
said heat sink having a first side and a second side;
a first optical means attached to said first side of said heat sink;
5 a second optical means attached to said second side of said heat sink;
said housing having a top and a bottom;
a top cap covering said top of said housing; and
a bottom cap covering said bottom of said housing.
16. The housing of claim 15, wherein said first optical means is selected from the
10 group comprising light-emitting diodes, high-intensity discharge lamps, halogen
lights, cameras, infra red devices and heat sensitive devices.
17. The housing of one of claims 15 or 16, wherein said second optical means is
selected from the group comprising light-emitting diodes, high-intensity discharge
lamps, halogen lights, cameras, infra red devices and heat sensitive devices.
- 15 18. The housing of claim 15, wherein said first optical means comprises:
a length of printed circuit board mounted to said first side of said heat sink;
at least one light-emitting diode mounted to said printed circuit board;
a lens mounted over said printed circuit board; and
a first bezel connecting said projection lens and said printed circuit board to said
20 first side of said heat sink;
19. The housing of one of claims 15 or 16, wherein said second optical means
comprises:
a halogen lamp housing;
a halogen lamp; and
25 a second bezel connecting said halogen lamp housing and said halogen lamp to
said second side of said heat sink.
20. The housing of one of claims 15 to 19, wherein:
said top cap includes a first set of openings;
said bottom cap includes a second set of openings; and

wherein air enters at said second set of openings, travels behind said heat sink, and exits at said first set of openings, transferring heat away from said heat sink.

21. The housing of one of claims 15 to 20 further comprising a fan.

22. The rotatable mounting system of claims 1 through 8 wherein said optical means
5 is one of the housings claimed in claims 15 to 17.

23. The rotatable mounting system of claims 1 through 8 wherein said optical device is the housing claimed in claim 18.

24. The rotatable mounting system of claims 1 through 8 wherein said optical device is the housing claimed in claim 19.

10

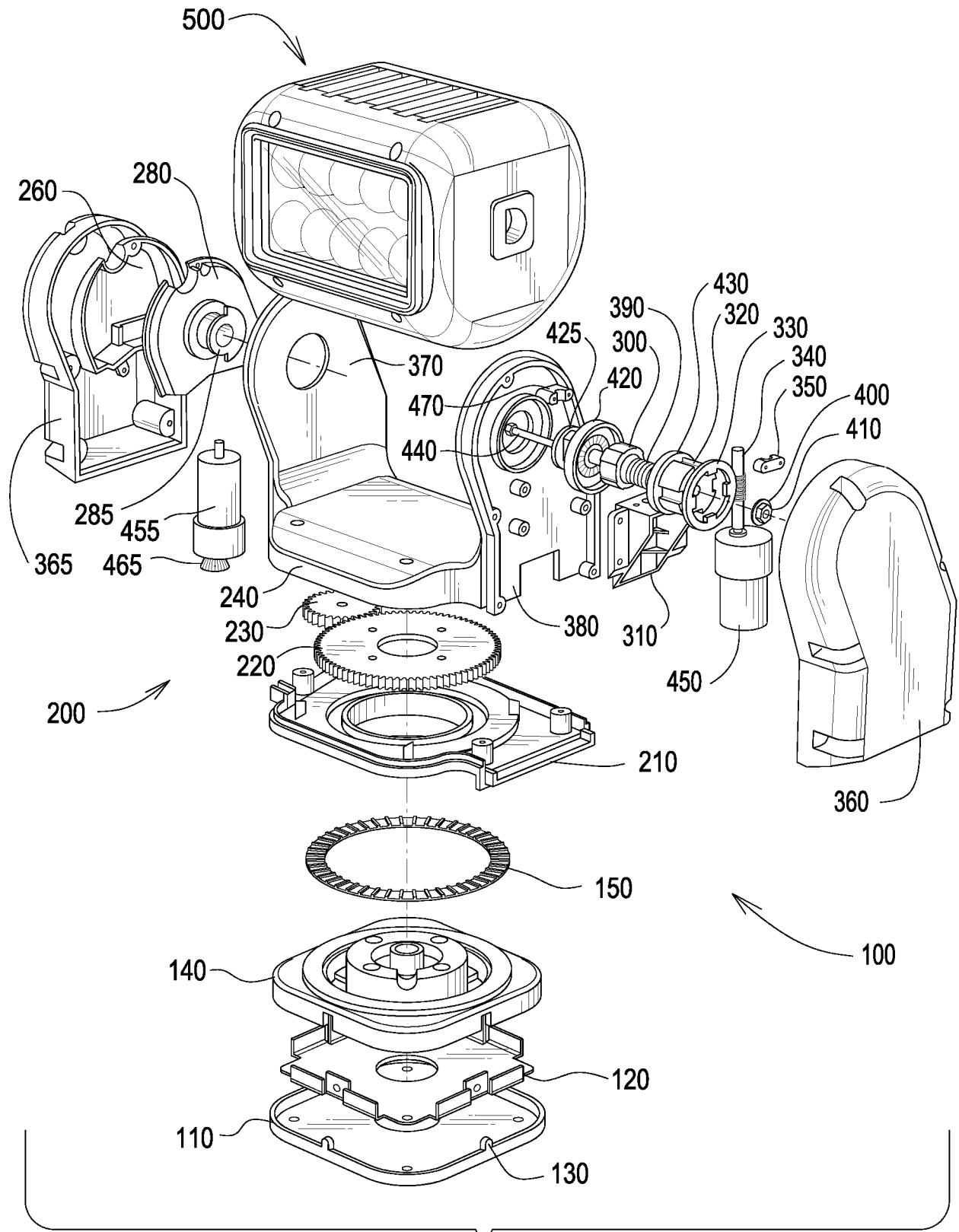

FIG.1

2 / 10

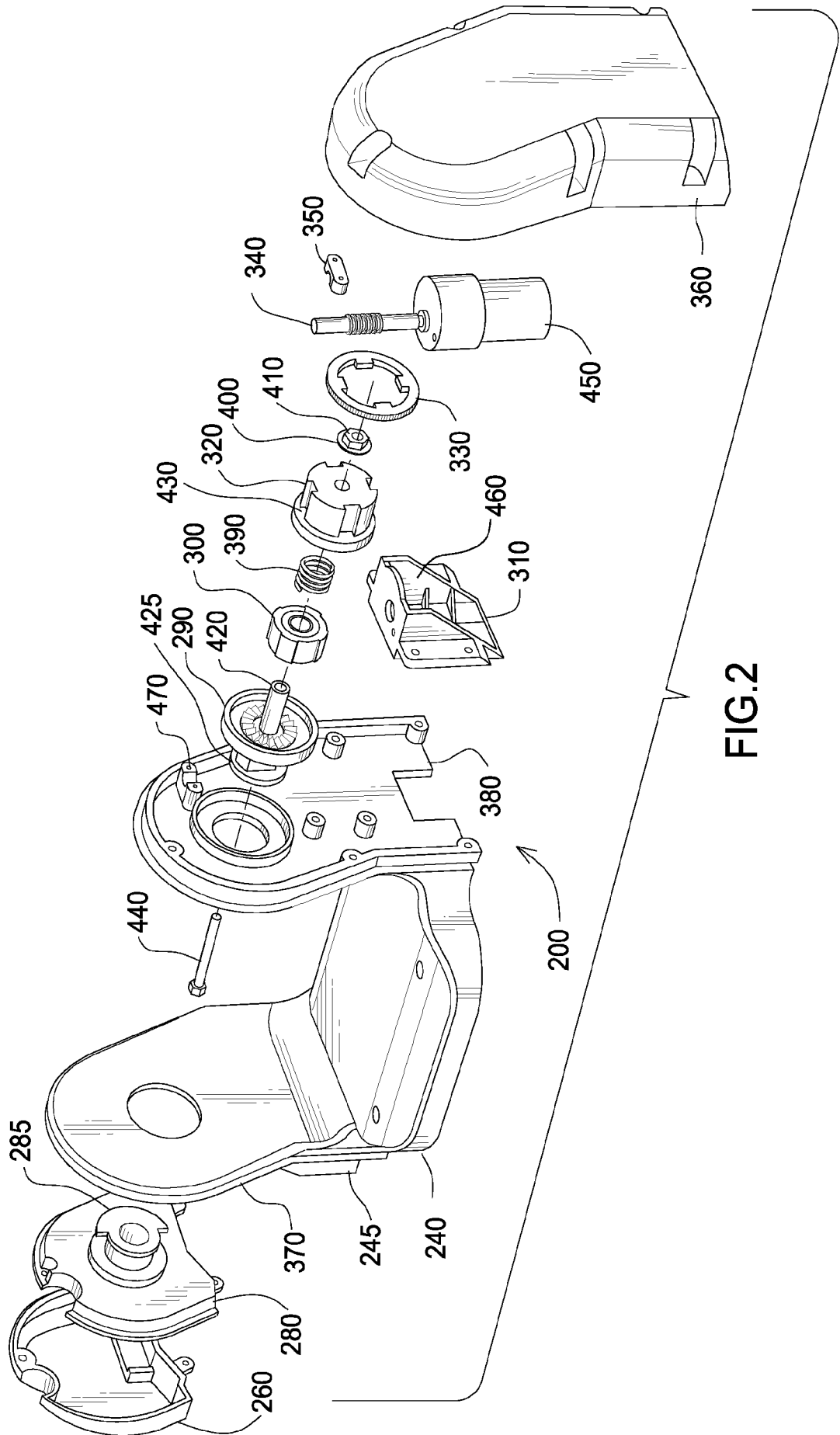

FIG.2

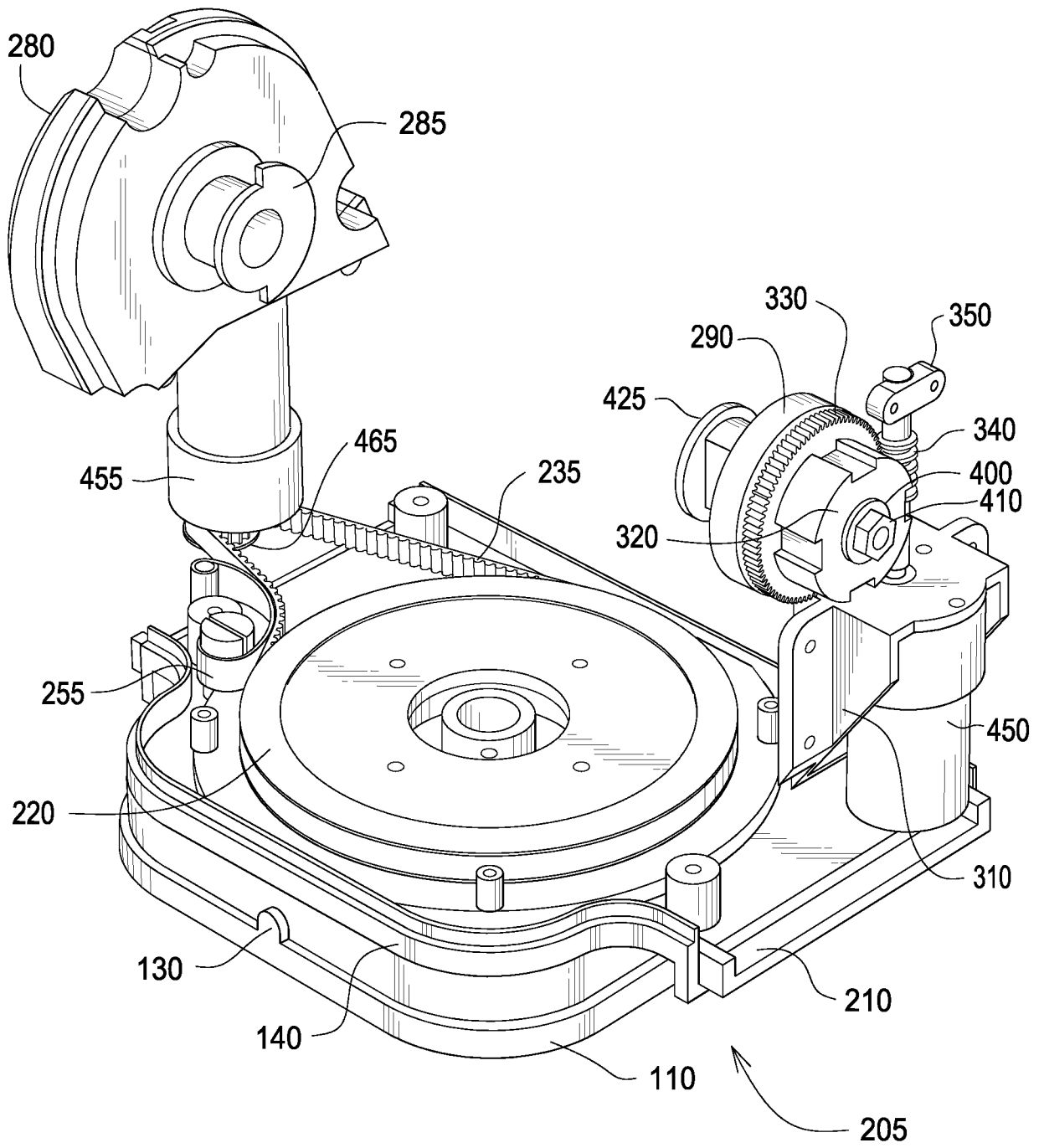

FIG.3

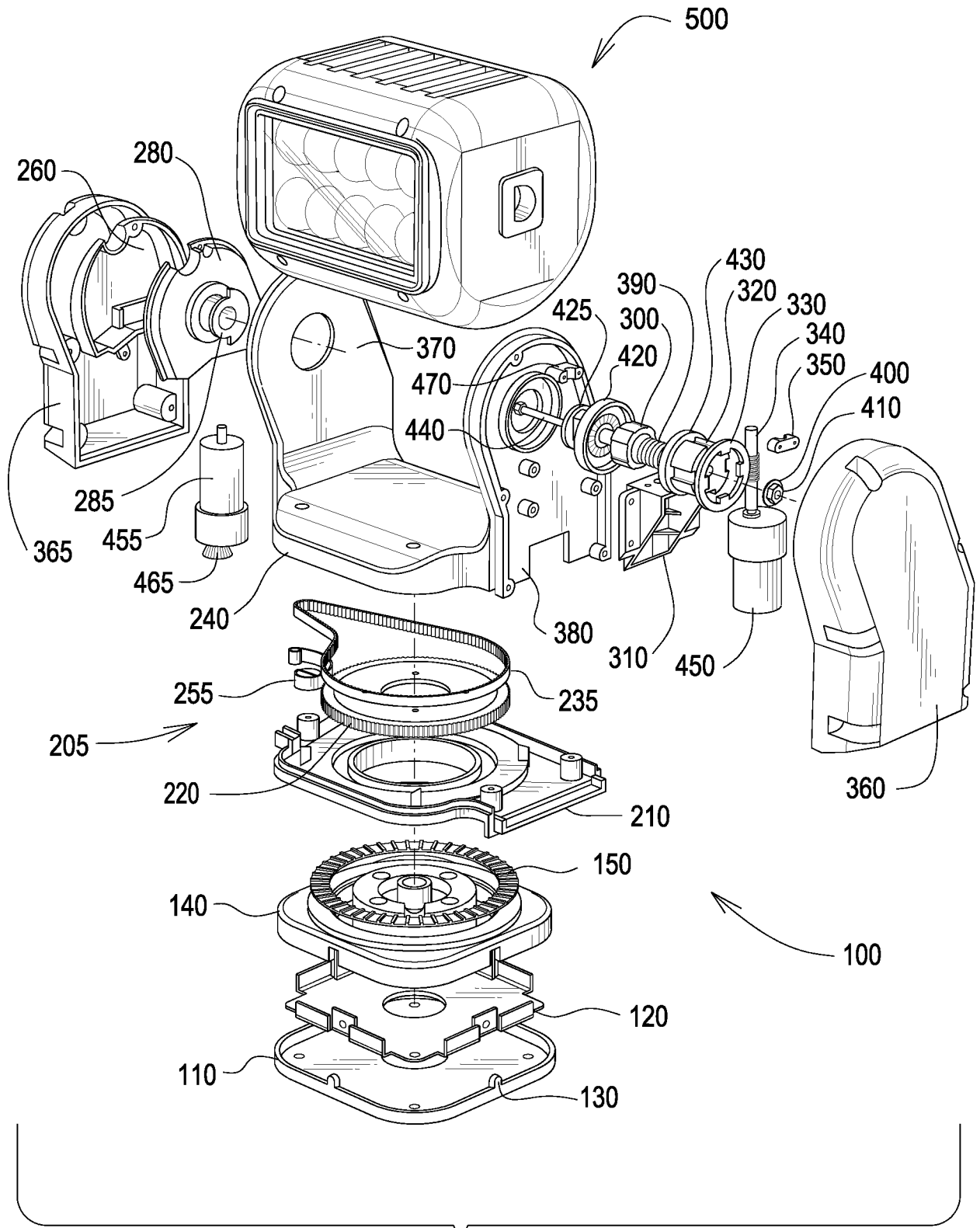

FIG.4

5 / 10

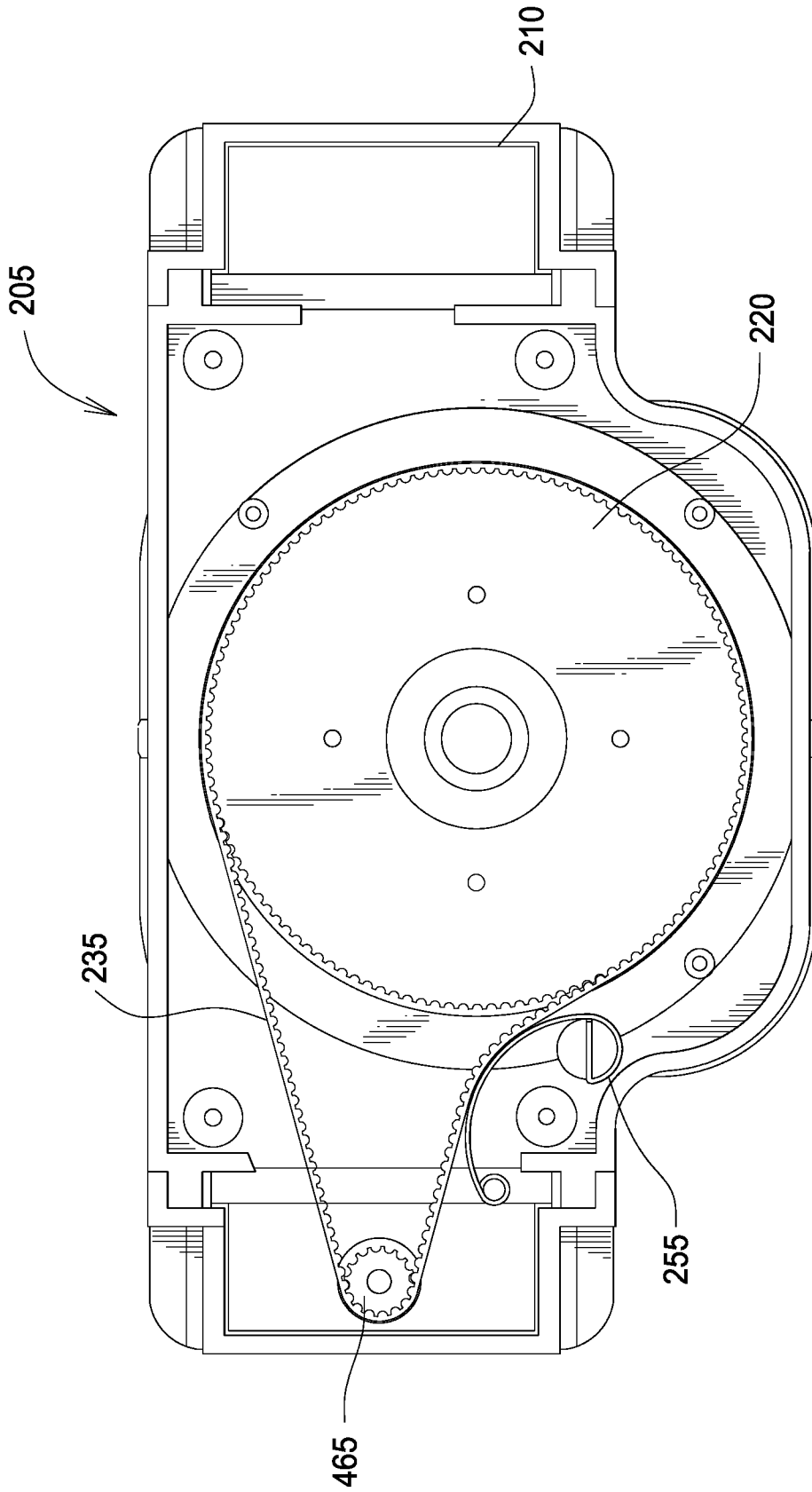

FIG.5

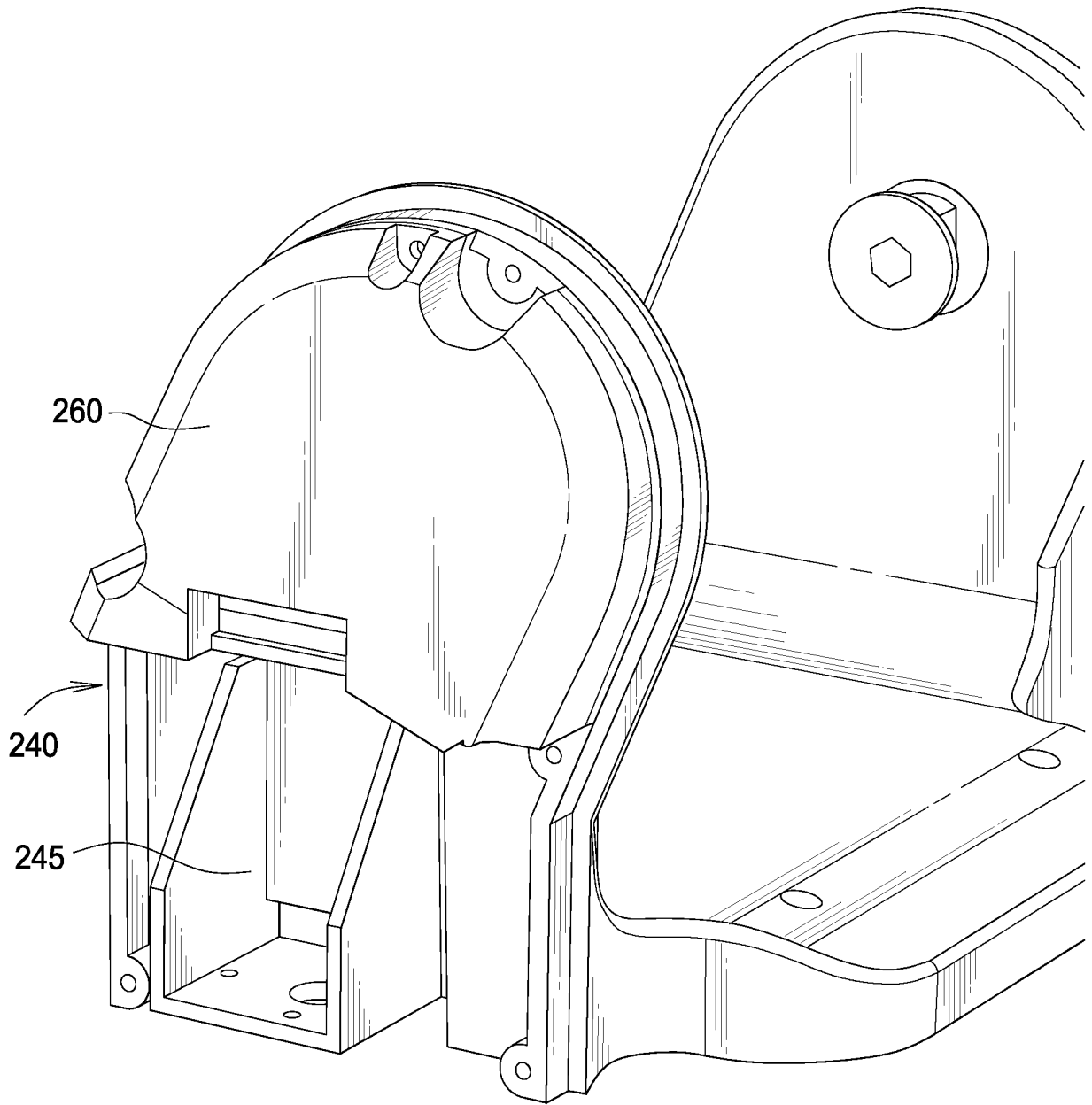

FIG.6

7 / 10

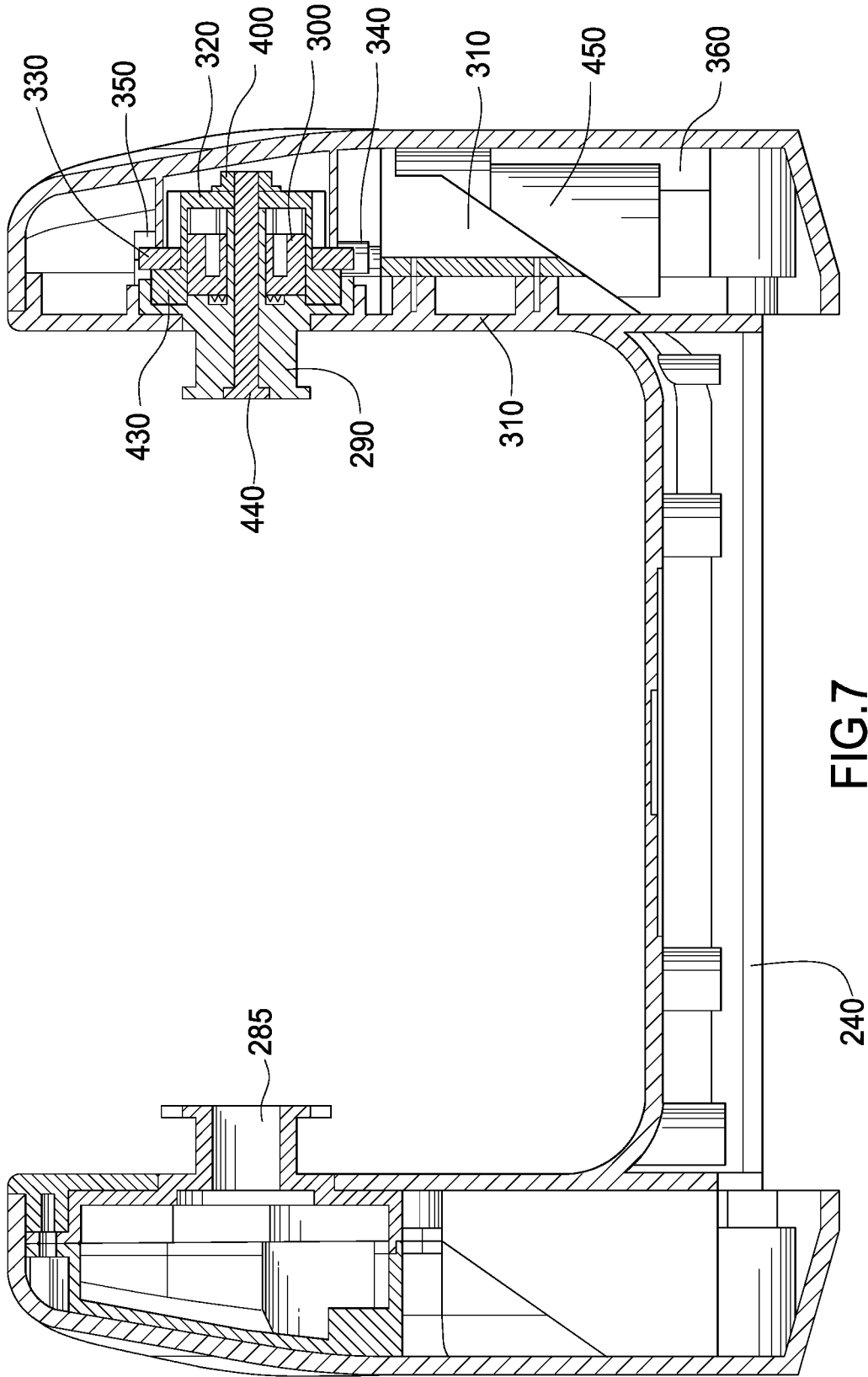
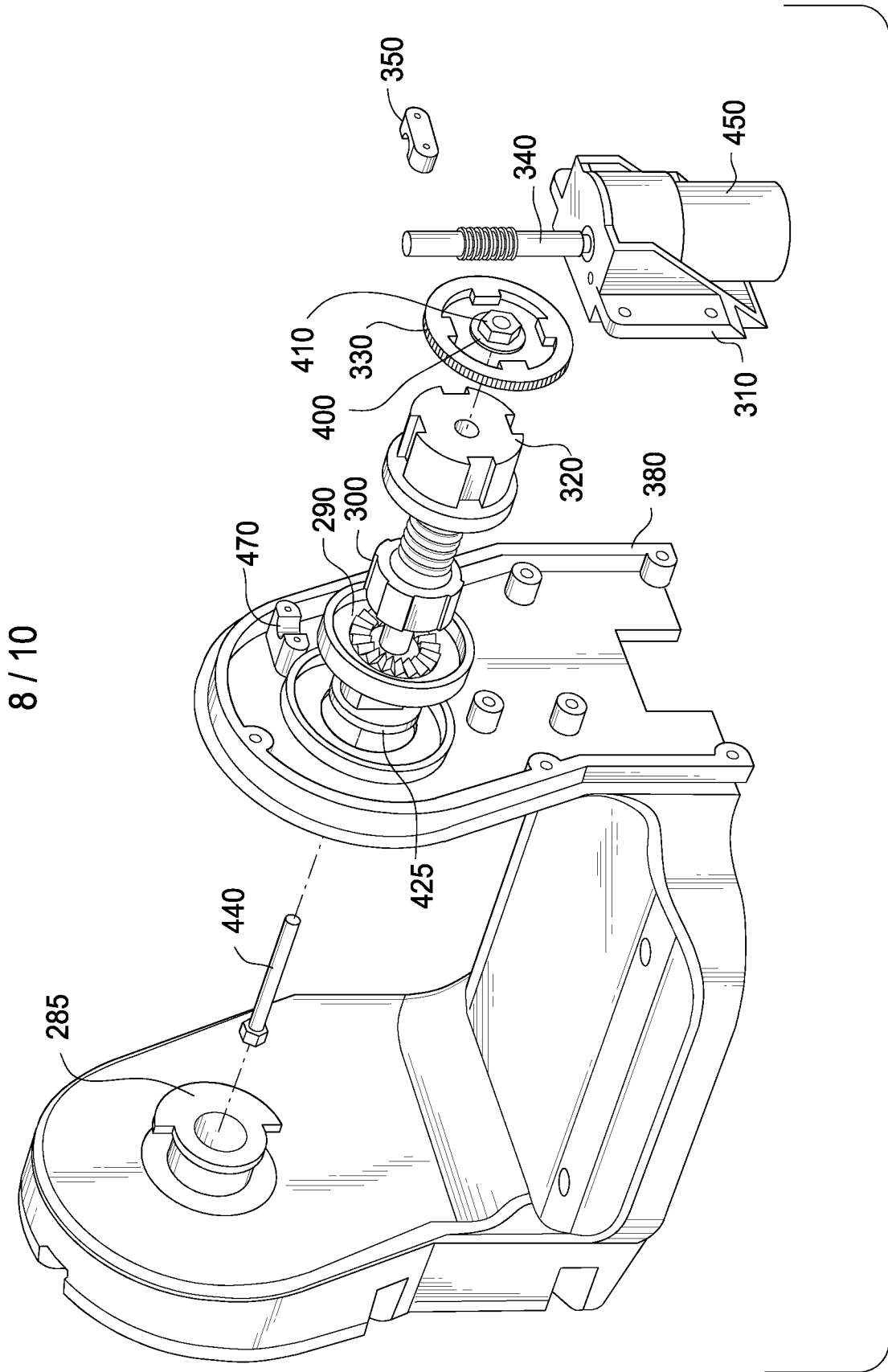

FIG. 7



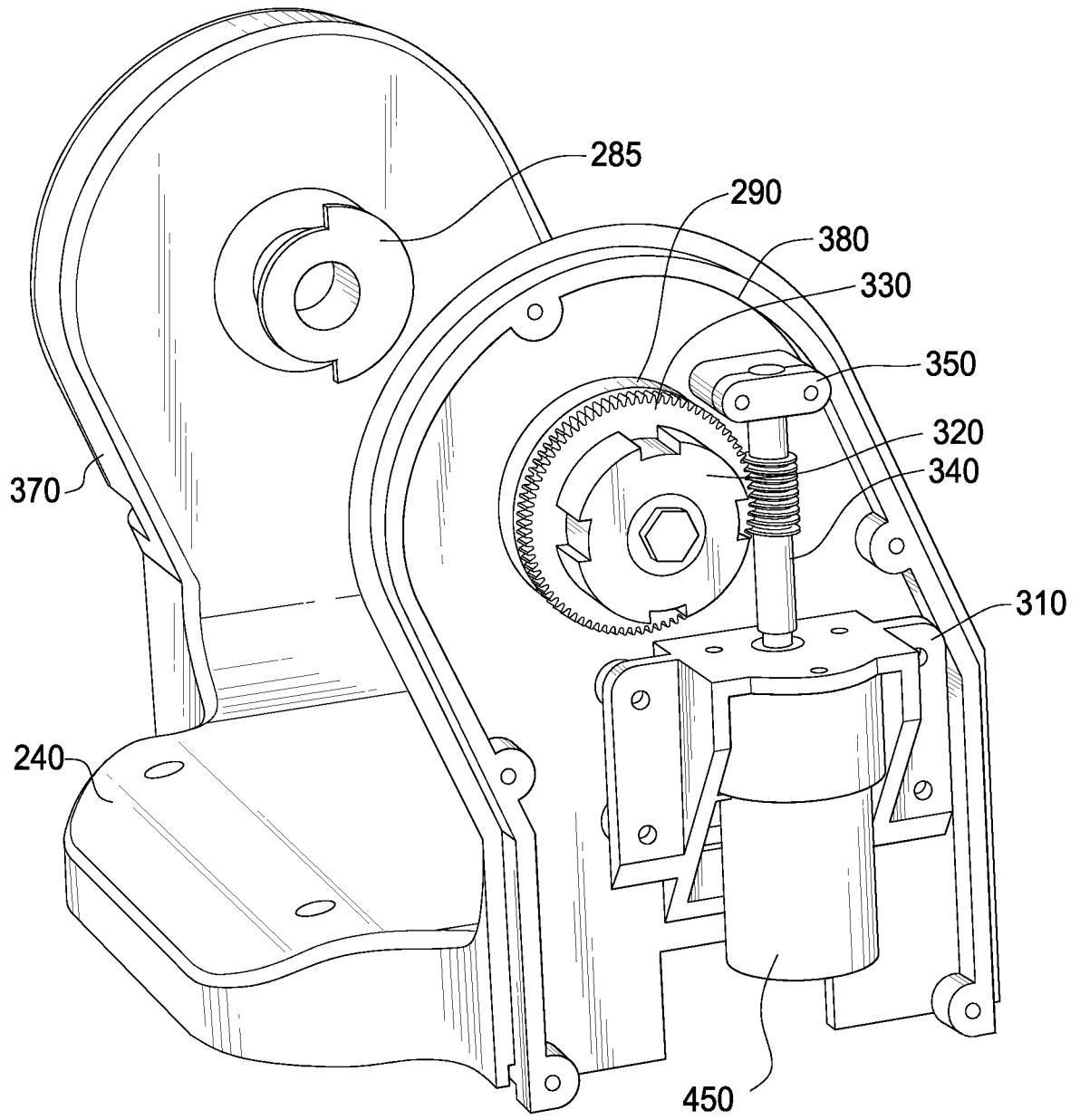

FIG.9

