

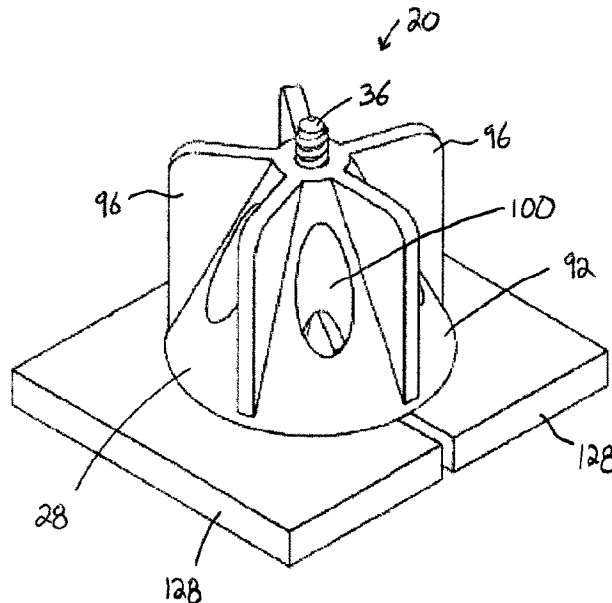

(22) Date de dépôt/Filing Date: 2015/10/21
 (41) Mise à la disp. pub./Open to Public Insp.: 2016/12/17
 (45) Date de délivrance/Issue Date: 2023/10/24
 (62) Demande originale/Original Application: 2 909 720
 (30) Priorité/Priority: 2015/06/17 (US14/742,229)

(51) Cl.Int./Int.Cl. *E04F 21/20* (2006.01),
E04F 15/08 (2006.01)
 (72) Inventeur/Inventor:
RUSSO, WILLIAM P., US
 (73) Propriétaire/Owner:
RUSSO TRADING COMPANY, INC., US
 (74) Agent: MARKS & CLERK

(54) Titre : DISPOSITIF DE NIVELLEMENT DE PLANCHER
 (54) Title: FLOOR LEVELING DEVICE



(57) Abrégé/Abstract:

A floor leveling device for leveling tiles includes a base having a plate and a stem. The plate has a planar upper surface configured to engage the tiles and an angled lower surface opposite the planar upper surface. The stem extends generally perpendicularly from the planar upper surface. The floor leveling device also includes a cap coupled to the stem for movement along the stem.

ABSTRACT

A floor leveling device for leveling tiles includes a base having a plate and a stem. The plate has a planar upper surface configured to engage the tiles and an angled lower surface opposite the planar upper surface. The stem extends generally perpendicularly from the planar upper surface. The floor leveling device also includes a cap coupled to the stem for movement along the stem.

FLOOR LEVELING DEVICE

BACKGROUND

This is a divisional application of Canadian Patent Application Serial No. 2,909,720 filed on October 21, 2015.

[0001] The present invention relates to leveling devices, such as devices for leveling floor tiles.

It should be understood that the expression “the invention” and the like used herein may refer to subject matter claimed in either the parent or the divisional applications.

[0002] When installing tiles on a floor, it is typically desirable to keep the tiles flat with respect to each other. Some prior art devices have been used to facilitate leveling tiles. One example of such a device includes a knob that threads onto a shaft positioned between two tiles. With this device, however, grout has a tendency to get between the device and the underside of the tiles, resulting in improper seating. In addition, as the knob is tightened, grout may squeeze out between the tiles and accumulate in the area under the knob without the user's knowledge. The grout then needs to be chipped off of the tiles after the knob is removed. Furthermore, the knob may not seat properly on top of the tiles if a granular piece of grout becomes trapped between the tiles and the knob.

SUMMARY

[0003] In one embodiment, the invention provides a floor leveling device for leveling tiles. The floor leveling device includes a base having a plate and a stem. The plate has a planar upper surface configured to engage the tiles and an angled lower surface opposite the planar upper surface. The stem extends generally perpendicularly from the

planar upper surface. The floor leveling device also includes a cap coupled to the stem for movement along the stem.

[0004] In another embodiment, the invention provides a floor leveling device for leveling tiles, the floor leveling device comprising:

a base including a plate and a stem extending generally perpendicularly from the plate, the stem has a threaded portion, the base having perforations formed between the plate and the stem to facilitate separating the stem from the plate; and

a cap threadably coupled to the threaded portion of the stem for movement along the stem, the cap including a threaded bore for receiving the stem and an aperture spaced apart from the threaded bore for viewing portions of the tiles beneath the cap;

wherein the cap includes a frustoconically-shaped body; and

wherein the cap also includes a plurality of flanges extending radially outward from the frustoconically-shaped body, and wherein the plurality of flanges is circumferentially spaced around the frustoconically shaped body.

According to an aspect of the present invention, there is provided a floor leveling device for leveling tiles, the floor leveling device comprising:

a base including a plate and a stem extending generally perpendicularly from the plate, the stem having a threaded portion, the base having perforations formed between the plate and the stem to facilitate separating the stem from the plate; and

a cap threadably coupled to the threaded portion of the stem for movement along the stem, the cap including a frustoconically-shaped body having a bottom surface, the bottom surface defining a diameter, a threaded bore through the frustoconically-shaped body and configured to receive the stem, an aperture through the frustoconically-shaped body spaced apart from the threaded bore and configured to allow viewing portions of the tiles beneath the cap,

a plurality of flanges extending radially outward from the frustoconically-shaped body, the plurality of flanges being circumferentially spaced around the frustoconically shaped body,

and a ridge extending downwardly from the bottom surface and which is configured to engage the tiles while reducing friction between the cap and the tiles, the ridge being a continuous, annular rib having a diameter that is different than the diameter of the bottom surface.

According to another aspect of the present invention, there is provided, a floor leveling device for leveling tiles, the floor leveling device comprising:

a base including a plate and a stem, the plate having a planar upper surface configured to engage the tiles and an angled lower surface opposite the planar upper surface, the plate including a notch formed through the planar upper surface and the angled lower surface at an edge of the plate, the stem extending generally perpendicularly from the planar upper surface, the stem having a threaded portion; and

a cap threadedly coupled to the threaded portion of the stem for movement along the threaded portion of the stem.

According to another aspect of the present invention, there is provided, a floor leveling device for leveling tiles, the floor leveling device comprising:

a base including a plate and a stem extending upward from the plate, the plate having a planar upper surface configured to engage the tiles and a first angled lower surface opposite the planar upper surface and adjacent a first planar edge of the plate, a second angled lower surface opposite the planar upper surface and adjacent a second planar edge of the plate, the first and second edges being parallel to each other, the plate including a first notch formed through the planar upper surface and the first angled lower surface and extending from the first edge of the plate, and a second notch formed through the planar upper surface and the second angled lower surface and extending from the second edge of the plate, the stem having a lower flattened portion extending generally perpendicularly from the planar upper surface of the plate and parallel to the first and second edges, the lower flattened portion maintaining a desired spacing between adjacent tiles, and an upper portion extending from the lower portion, the lower flattened portion having opposite planar sides which are parallel to each other, wherein the base includes perforations formed between the

lower flattened portion and the upper surface of the plate to facilitate separating the stem from the plate, wherein the planar upper surface of the plate surrounds all sides of the lower flattened portion of the stem, the upper portion being threaded; and

a cap threadedly coupled to the upper portion of the stem for movement along the upper portion of the stem.

[0005] In yet another embodiment, the invention provides a floor leveling device for leveling tiles. The floor leveling device includes a base having a plate with a planar upper surface configured to engage the tiles, a first angled lower surface opposite the planar upper surface and adjacent a first edge of the plate, a second angled lower surface opposite the planar upper surface

and adjacent a second edge of the plate, a first notch formed through the planar upper surface and the first angled lower surface at the first edge, and a second notch formed through the planar upper surface and the second angled lower surface at the second edge. The base also has a stem extending generally perpendicularly from the planar upper surface of the plate. The stem includes a threaded portion and a flattened portion positioned between the plate and the threaded portion. The floor leveling device also includes a cap threadably coupled to the threaded portion of the stem for movement along the stem. The cap includes a plurality of flanges extending radially outward from the cap, a plurality of apertures positioned between the plurality of flanges for viewing portions of the tiles beneath the cap, and a ridge formed on a bottom surface of the cap and configured to engage the tiles.

[0006] Other aspects of the invention will become apparent by consideration of the detailed description and accompanying drawings.

BRIEF DESCRIPTION OF THE DRAWINGS

[0007] Fig. 1 is a top perspective view of a floor leveling device including a base and a cap.

[0008] Fig. 2 is a side view of the floor leveling device.

[0009] Fig. 3 is a top perspective view of the base.

[0010] Fig. 4 is a side view of the base.

[0011] Fig. 5 is a top view of the base.

[0012] Fig. 6 is a top perspective view of the cap.

[0013] Fig. 7 is a bottom perspective view of the cap.

[0014] Fig. 8 is a top perspective view of the floor leveling device in use with two tiles.

[0015] Fig. 9 is a bottom perspective view of the floor leveling device in use with two tiles.

[0016] Fig. 10 is a top view of the floor leveling device in use with two tiles.

DETAILED DESCRIPTION

[0017] Before any embodiments of the invention are explained in detail, it is to be understood that the invention is not limited in its application to the details of construction and the arrangement of components set forth in the following description or illustrated in the following drawings. The invention is capable of other embodiments and of being practiced or of being carried out in various ways.

[0018] Figs. 1-2 illustrate a floor leveling device 20 including a base 24 and a cap 28. The floor leveling device 20 is usable to help level, for example, tiles on a floor, wall, or other surface. In use, a portion of the base 24 is positioned beneath the tiles (e.g., between the tiles and the floor), and the cap 28 is moved along another portion of the base 24 to engage the tiles. The base 24 and the cap 28 capture portions of the tiles therebetween to help level and space the tiles relative to each other. Grout, caulk, and/or other bonding or adhesive materials introduced underneath and between the tiles to secure the tiles together.

[0019] As shown in Figs. 3-5, the illustrated base 24 includes a plate 32 and a stem 36. The plate 32 is the portion of the base 24 configured to be positioned beneath the tiles. The plate 32 includes a planar upper surface 40 that is configured to engage the tiles. The illustrated upper surface 40 is planar, or flat, throughout and does not include any bumps or protrusions extending upwardly from the surface 40. As shown in Fig. 2, the plate 32 also includes two angled lower surfaces 44, 48 and a central planar section 52 that are opposite the planar upper surface 40. The angled surfaces 44, 48 extend in opposite directions from the central planar section 52. The first angled surface 44 extends from the central planar section 52 to a first edge 56 of the plate 32, and the second angled surface 48 extends from the central planar section 52 to a second edge 60 of the plate 32. The surfaces 44, 48 are angled (i.e., non-parallel) relative to the planar upper surface 40 of the plate 32. In the illustrated embodiment, the angled surfaces 44, 48 are oriented so that the plate 32 decreases in thickness, or tapers, toward the first edge 56 and toward the second edge 60. This arrangement provides a wedge-shaped profile toward the first edge 56 and the second edge 60.

[0020] Referring back to Figs. 3 and 5, the plate 32 also includes two notches 64, 68. The first notch 64 is formed through the planar upper surface 40 and the first angled lower surface 44

at the first edge 56. The second notch 68 is formed through the planar upper surface 40 and the second angled lower surface 48 at the second edge 60. In the illustrated embodiment, the notches 64, 68 are generally V-shaped. In other embodiments, the notches 64, 68 may be other suitable shapes (e.g., U-shaped, rectangular, etc.). In some embodiments, the plate 32 may include fewer or more notches at each edge 56, 60. As shown in Fig. 5, sides 72 of the plate 32 are also angled toward the notches 64, 68 so that the overall width of the plate 32 decreases toward the first and second edges 56, 60.

[0021] As shown in Figs. 3-4, the stem 36 extends generally perpendicularly from the planar upper surface 40 of the plate 32. The illustrated stem 36 includes a threaded portion 76 and a flattened portion 80. The threaded portion 76 is formed at a distal or free end of the stem 36. The threaded portion 76 includes threads that threadably engage to the cap 28. The threaded portion 76 allows the cap 28 to move along the stem 36 toward and away from the plate 32. In some embodiments, the threaded portion 76 may be replaced with a toothed portion that engages the cap 28 via a ratchet-type mechanism. In the illustrated embodiment, the threaded portion 76 accounts for a majority (i.e., over 50 percent) of the overall length of the stem 36. In some embodiments, the threaded portion 76 may extend the entire length of the stem 36, and the flattened portion 80 may be omitted.

[0022] The flattened portion 80 is positioned between the plate 32 and the threaded portion 76. The flattened portion 80 is shaped and sized to create and maintain a desired spacing between adjacent tiles. The illustrated flattened portion 80 includes two vertically-extending, planar surfaces 84 that are configured to engage and space apart edges of two tiles. The planar surfaces 84 provide the flattened portion 80 with a generally rectangular cross-section to fit between the tiles. In other embodiments, the flattened portion 80 may have an X- or cross-shaped cross-section to fit between and space apart four tiles at their corners.

[0023] As shown in Fig. 4, the illustrated base 24 also includes perforations 88 formed between the plate 32 and the stem 36. In particular, the perforations 88 are formed between the upper surface 40 of the plate 32 and the flattened portion 80 of the stem 36. The perforations 88 may be, for example, notches or score lines to remove material between the plate 32 and the stem 36. The perforations 88 facilitate separating (e.g., snapping apart) the stem 36 from the plate 32.

[0024] Figs. 6 and 7 illustrate the cap 28 of the floor leveling device 20. The cap 28 couples to the stem 36 to capture portions of tiles between the cap 28 and the plate 32. In the illustrated embodiment, the cap 28 is threadably coupled to the threaded portion 76 of the stem 36. This threaded connection allows the cap 28 to move along the stem 36 toward and away from the plate 32.

[0025] The illustrated cap 28 includes a body 92, a plurality of flanges 96, and a plurality of apertures 100. In the illustrated embodiment, the body 92 is a frustoconically-shaped body having a larger diameter end 104 near the plate 32 of the base 24, and a smaller diameter end 108 opposite from the plate 32 of the base 24. The body 92 includes a threaded bore 112 (Fig. 6) at the smaller diameter end 108. The threaded bore 112 receives and engages the threaded portion 76 of the stem 36. The body 92 also includes an inner bore 116 (Fig. 7) extending from the larger diameter end 104 to the threaded bore 112. The inner bore 116 is sized to at least partially receive the flattened portion 80 of the stem 36 when the cap 28 is threaded onto the stem 36. The inner bore 116 thereby provides clearance in the cap 28 for the cap 28 to fit over the flattened portion 80 and move closer to the plate 32.

[0026] The flanges 96 extend radially outward from the body 92. In the illustrated embodiment, the cap 28 includes five flanges 96 that are circumferentially spaced around the body 92. Each flange 96 provides a handle or grip to facilitate turning the cap 28 on the stem 36 of the base 24. In other embodiments, the cap 28 may include fewer or more flanges. Additionally or alternatively, the flanges 96 may be spaced in different arrangements around the cap 28. In some embodiments, the flanges 96 may be omitted so that a user directly grasps the body 92 of the cap 28 to turn the cap 28.

[0027] The apertures 100 are formed through the body 92. In the illustrated embodiment, the cap 28 includes five apertures 100 that are circumferentially spaced around the body 92 of the cap 28. The illustrated apertures 100 are equally spaced apart such that each aperture 100 is positioned between two adjacent flanges 96. In other embodiments, the cap 100 may include fewer or more apertures. Additionally or alternatively, the apertures 100 may be spaced in different arrangements around the cap 28. The illustrated apertures 100 extend in a direction generally parallel to an axis of rotation of the cap 28 (and, thereby, a longitudinal axis of the

stem 36). Orienting the apertures 100 in this manner provides a view through the cap 28 so that a user can see areas beneath the cap. More specifically, the apertures 100 allow a user to view portions of the tiles beneath the cap 28 to see, for example, if grout is squeezing out between the tiles underneath the cap 28.

[0028] As shown in Figs. 2 and 7, the cap 28 also includes a ridge 120 formed on a bottom surface 124 of the body 92 (i.e., the surface of the body 92 at the larger diameter end 104 and facing the plate 32). The ridge 120 extends downwardly from the body 92 toward the plate 32 of the base 24. In the illustrated embodiment, the ridge 120 is a continuous, annular rib formed on the bottom surface 124 of the cap 28. In other embodiments, the ridge 120 may include a series of discrete bumps or ribs formed on the bottom surface 124 of the cap 28. The ridge 120 is configured to engage upper surfaces of the tiles when the cap 28 is threaded onto the stem 36 of the base 24 to reduce the chance of grout getting caught between the cap 28 and the tiles. The ridge 120 also reduces friction between the cap 28 and the tiles when spinning the cap 28 onto the base 24. Furthermore, the ridge 120 reduces the possibility of marring the tiles as the cap 28 is spun onto the base 24.

[0029] In the illustrated embodiment, the base 24 and the cap 28 are composed of plastic (e.g., polyethylene, polyvinyl chloride, nylon, etc.). More particularly, the base 24 and the cap 28 are made of molded or injection molded plastic. In other embodiments, the base 24 and the cap 28 may be made of other or differing materials. For example, the base 24 may be made of plastic, and the cap 28 may be made of metal or wood. Alternatively, the base 24 and the cap 28 may be made of different types of plastics.

[0030] Figs. 8-10 illustrate the floor leveling device 20 in use. During use, the plate 32 of the base 24 is positioned between two adjacent tiles 128. This may occur by, for example, positioning one tile 128 on a floor (which is coated with grout), sliding approximately half of the plate 32 under the tile 128 so that the flattened portion 80 of the stem 36 abuts the edge of the tile 128, and positioning the other tile 128 on top of the other half of plate 32 so that the flattened portion 80 of stem 36 abuts the edge of the other tile 128. As the plate 32 is slid under the tile 128 (and the other tile 128 is slid onto the plate 32), the planar upper surface 40 of the plate 32 scrapes grout off of the underside of the tile 128, creating a relatively clean interface between the

plate 32 and the tile 128. The notches 64, 68 and the angled lower surfaces 44, 48 of the plate 32 also reduce the amount of space taken up by the plate 32 so that excess grout may accumulate within the notches 64, 68 or under the angled lower surfaces 44, 48 without being displaced unfavorably elsewhere.

[0031] After the plate 32 is installed under the tiles 128, the cap 28 is coupled to the stem 36. In the illustrated embodiment, the cap 28 is threaded (e.g., spun or rotated) onto the threaded portion 76 of the stem 36. As the cap 28 is threaded onto the stem 36, a user can see if any grout is squeezed out from between the tiles 120 using the apertures 100 (as viewed in Fig. 10). The user can then clean/remove the grout before the grout hardens on the upper surfaces of the tiles 128. The cap 28 is threaded onto the stem 36 until the ridge 120 on the bottom surface 124 engages the tiles 128. Once the ridge 120 engages the tiles 128, further tightening of the cap 28 can shift the tiles 128 vertically to help level the tiles 128 relative to each other. This process can be performed on all of the tiles 128 on a floor or other surface.

[0032] Once the tiles 128 are leveled and set (e.g., once the grout hardens), the cap 28 is removed (e.g., unthreaded) from the stem 36 of the base 24. Then, the stem 36 is separated from the plate 32 by, for example, snapping the stem 36 apart from the plate 32 along the perforations 88 (Fig. 4). Once the cap 28 and the stem 36 are removed, gaps between the tiles 128 can be filled with grout. The plates 32 are left beneath the tiles 128 and covered by the grout.

Aspects of the present invention are provided by the following clauses:

1. A floor leveling device for leveling tiles, the floor leveling device comprising:
a base including a plate and a stem, the plate having a planar upper surface configured to engage the tiles and an angled lower surface opposite the planar upper surface, the stem extending generally perpendicularly from the planar upper surface; and
a cap coupled to the stem for movement along the stem.
2. The floor leveling device of clause 1, wherein the plate includes a notch formed through the planar upper surface and the angled lower surface at an edge of the plate.
3. The floor leveling device of clause 1, wherein the angled lower surface is a first angled lower surface adjacent a first edge of the plate, and wherein the plate includes a second angled lower surface opposite the planar upper surface and adjacent a second edge of the plate.
4. The floor leveling device of clause 3, wherein the first and second angled lower surfaces are oriented so that the plate decreases in thickness toward the first edge and toward the second edge.
5. The floor leveling device of clause 1, wherein the stem includes a threaded portion, and wherein the cap is threadably coupled to the threaded portion.
6. The floor leveling device of clause 5, wherein the stem also includes a flattened portion positioned between the plate and the threaded portion.
7. The floor leveling device of clause 6, wherein the cap includes an inner bore that partially receives the flattened portion of the stem.

8. The floor leveling device of clause 1, wherein the base includes perforations formed between the plate and the stem to facilitate separating the stem from the plate.

9. The floor leveling device of clause 1, wherein the cap includes an aperture for viewing portions of the tiles beneath the cap.

10. A floor leveling device for leveling tiles, the floor leveling device comprising:

a base including a plate and a stem extending generally perpendicularly from the plate, the stem having a threaded portion; and

a cap threadably coupled to the threaded portion of the stem for movement along the stem, the cap including an aperture for viewing portions of the tiles beneath the cap.

11. The floor leveling device of clause 10, wherein the cap includes a plurality of apertures for viewing portions of the tiles beneath the cap.

12. The floor leveling device of clause 11, wherein the plurality of apertures is circumferentially spaced around the cap.

13. The floor leveling device of clause 10, wherein the cap includes a flange extending radially outward from the cap.

14. The floor leveling device of clause 10, wherein the cap includes a frustoconically-shaped body.

15. The floor leveling device of clause 14, wherein the cap also includes a plurality of flanges extending radially outward from the frustoconically-shaped body, and

wherein the plurality of flanges is circumferentially spaced around the frustoconically-shaped body.

16. The floor leveling device of clause 15, wherein the cap further includes a plurality of apertures formed through the frustoconically-shaped body and positioned between the plurality of flanges.

17. The floor leveling device of clause 10, wherein the cap includes a ridge formed on a bottom surface of the cap, and wherein the ridge is configured to engage the tiles.

18. The floor leveling device of clause 17, wherein the ridge is a continuous, annular rib formed on the bottom surface of the cap.

19. The floor leveling device of clause 10, wherein the stem includes a flattened portion positioned between the plate and the threaded portion, and wherein the cap includes an inner bore that at least partially receives the flattened portion of the stem.

20. A floor leveling device for leveling tiles, the floor leveling device comprising:

a base including

a plate having a planar upper surface configured to engage the tiles, a first angled lower surface opposite the planar upper surface and adjacent a first edge of the plate, a second angled lower surface opposite the planar upper surface and adjacent a second edge of the plate, a first notch formed through the planar upper surface and the first angled lower surface at the first edge, and a second notch formed through the planar upper surface and the second angled lower surface at the second edge, and

a stem extending generally perpendicularly from the planar upper surface of the plate, the stem including a threaded portion and a flattened portion positioned between the plate and the threaded portion; and

a cap threadably coupled to the threaded portion of the stem for movement along the stem, the cap including a plurality of flanges extending radially outward from the cap, a plurality of apertures positioned between the plurality of flanges for viewing portions of the tiles beneath the cap, and a ridge formed on a bottom surface of the cap and configured to engage the tiles.

[0033] Various features and advantages of the invention are set forth in the following claims.

The embodiments of the invention in which an exclusive property or privilege is claimed are defined as follows:

1. A floor leveling device for leveling tiles, the floor leveling device comprising: a base including a plate and a stem extending upward from the plate, the plate having a planar upper surface configured to engage the tiles and a first angled lower surface opposite the planar upper surface and adjacent a first planar edge of the plate, a second angled lower surface opposite the planar upper surface and adjacent a second planar edge of the plate, the first and second edges being parallel to each other, the plate including a first notch formed through the planar upper surface and the first angled lower surface and extending from the first edge of the plate, and a second notch formed through the planar upper surface and the second angled lower surface and extending from the second edge of the plate, the stem having a lower flattened portion extending generally perpendicularly from the planar upper surface of the plate and parallel to the first and second edges, the lower flattened portion maintaining a desired spacing between adjacent tiles, and an upper portion extending from the lower portion, the lower flattened portion having opposite planar sides which are parallel to each other, wherein the base includes perforations formed between the lower flattened portion and the upper surface of the plate to facilitate separating the stem from the plate, wherein the planar upper surface of the plate surrounds all sides of the lower flattened portion of the stem, the upper portion being threaded; and

a cap threadedly coupled to the upper portion of the stem for movement along the upper portion of the stem.

2. The floor leveling device of claim 1, wherein the first and second angled lower surfaces are oriented so that the plate decreases in thickness toward the first edge and toward the second edge.

3. The floor leveling device of claim 1, wherein the cap includes an inner bore that partially receives the flattened portion of the stem.

4. The floor leveling device of claim 1, wherein the cap includes an aperture for viewing portions of the tiles beneath the cap.

5. The floor leveling device of claim 1, wherein the cap includes a plurality of radially extending flanges, apertures positioned between the flanges for viewing portions of the tiles beneath the cap, and a ridge formed on a bottom surface of the cap and configured to engage the tiles.

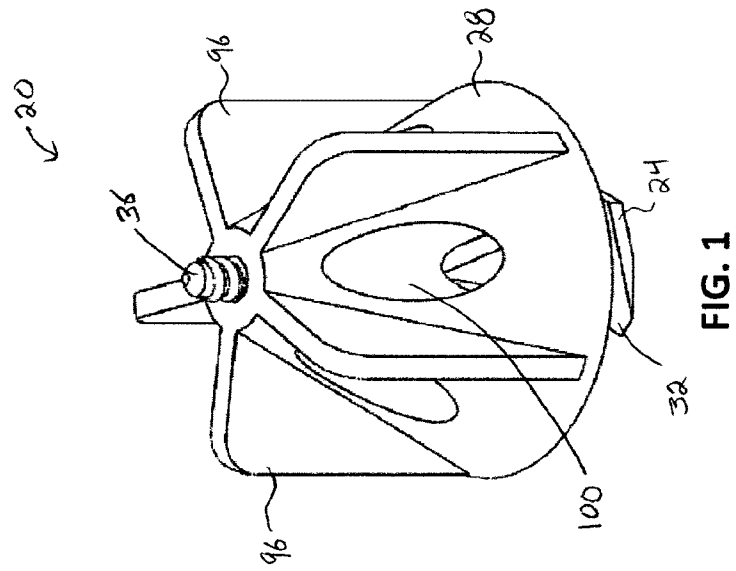
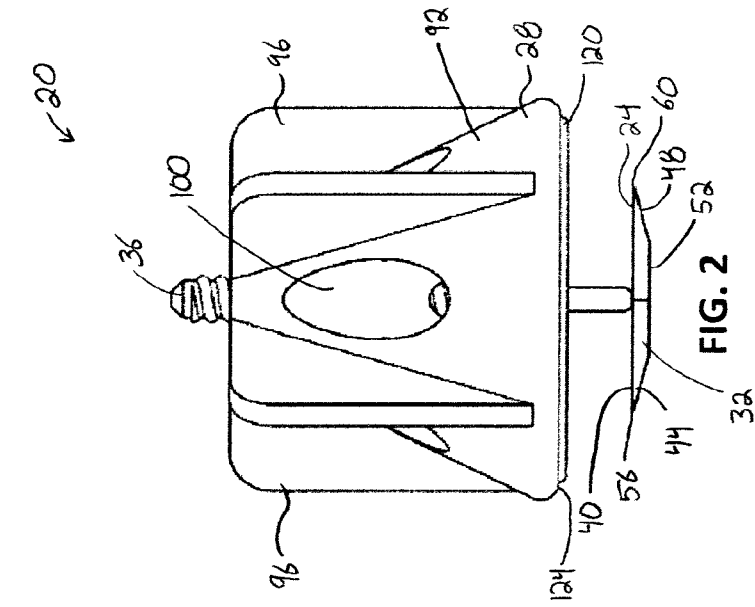

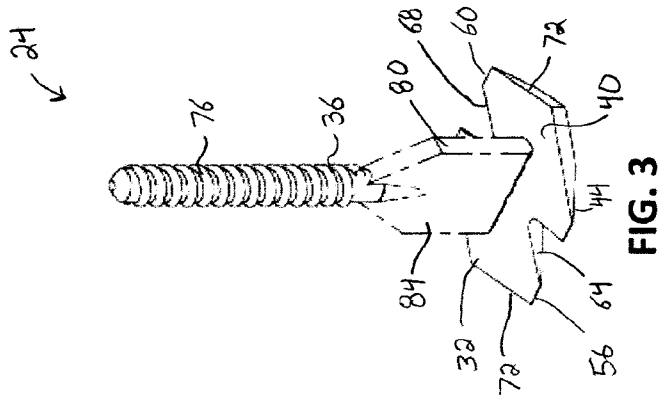
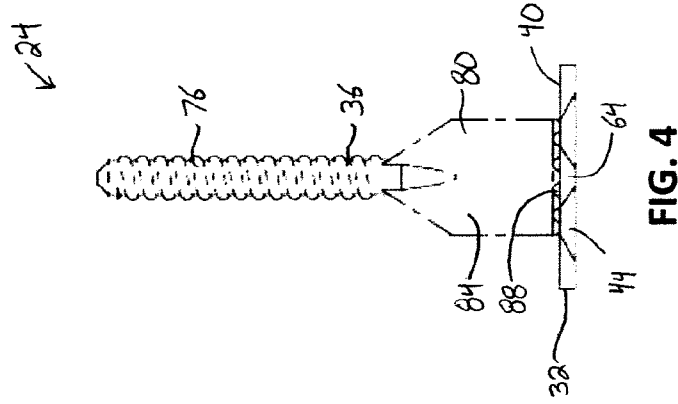
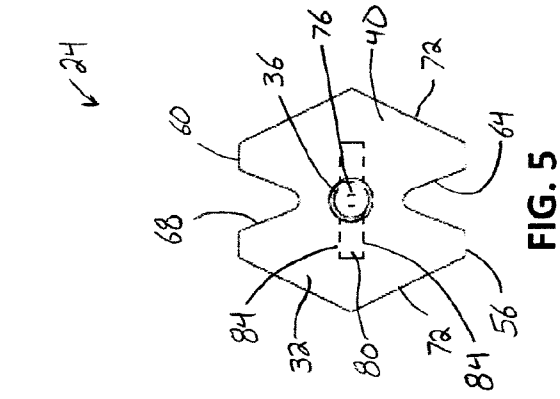

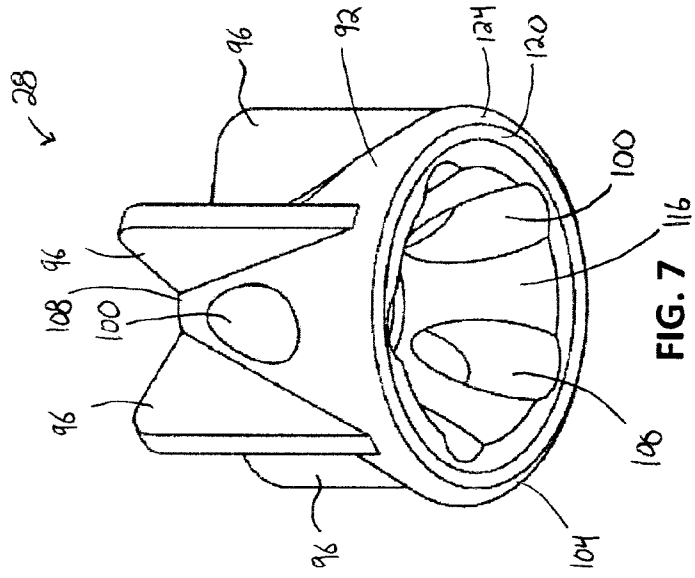

FIG. 7

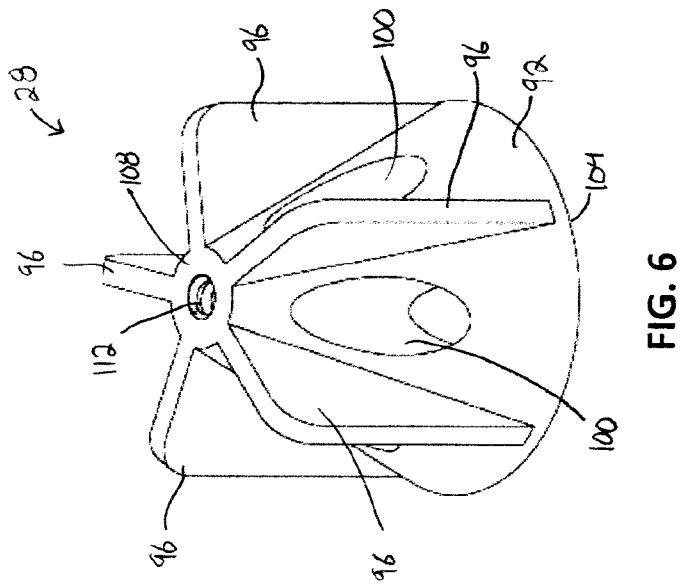
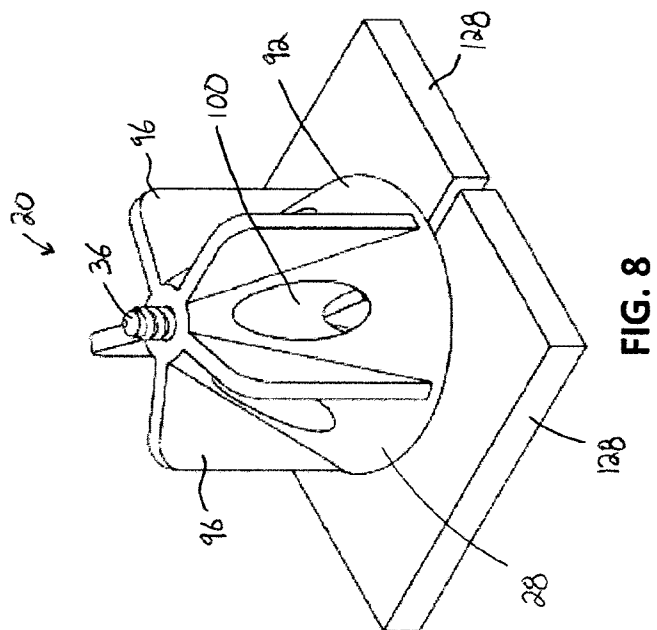
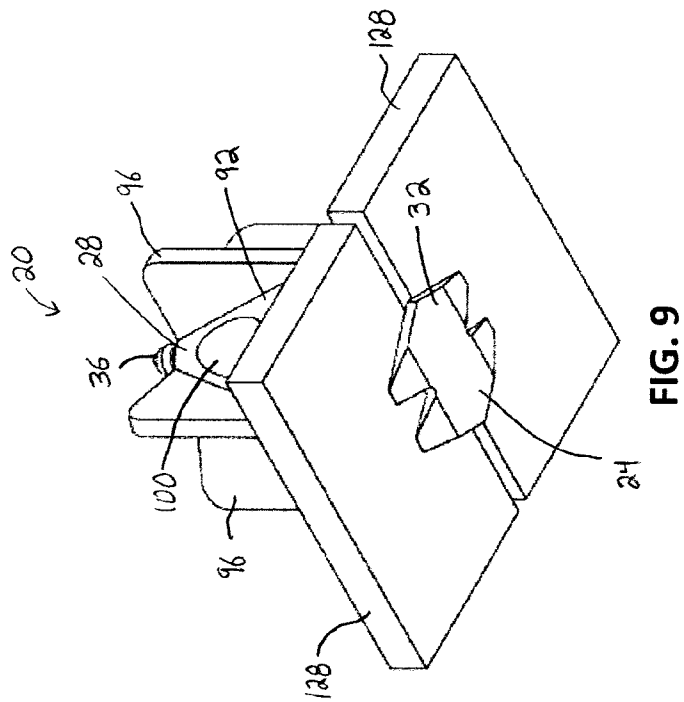

FIG. 6



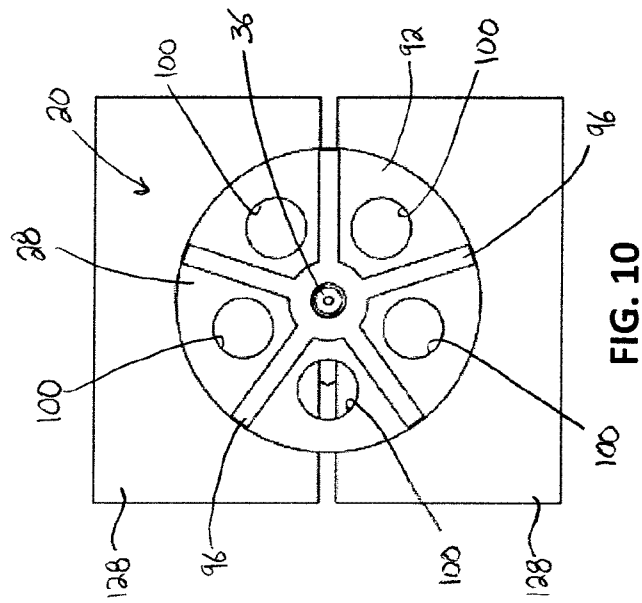

FIG. 10

