

H. J. ANDERSEN.

COMBINED BAND AND CIRCULAR SAWMILL.

No. 470,964.

Patented Mar. 15, 1892.

Fig. 1.

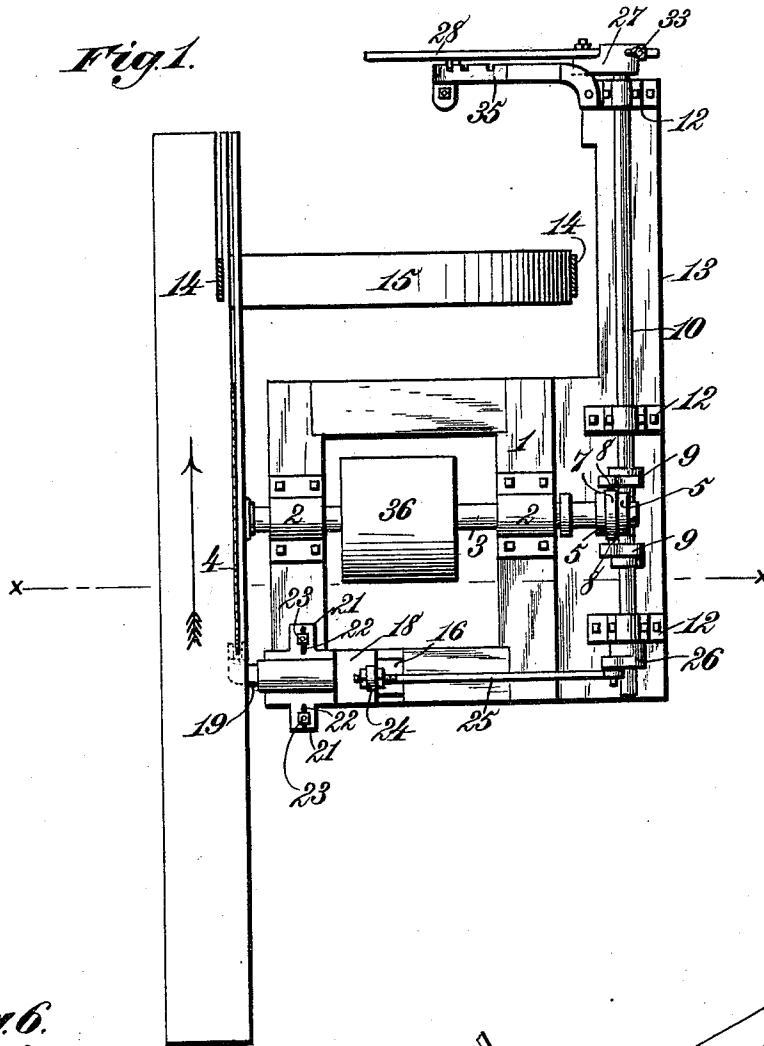

Fig. 6.

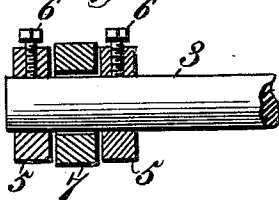
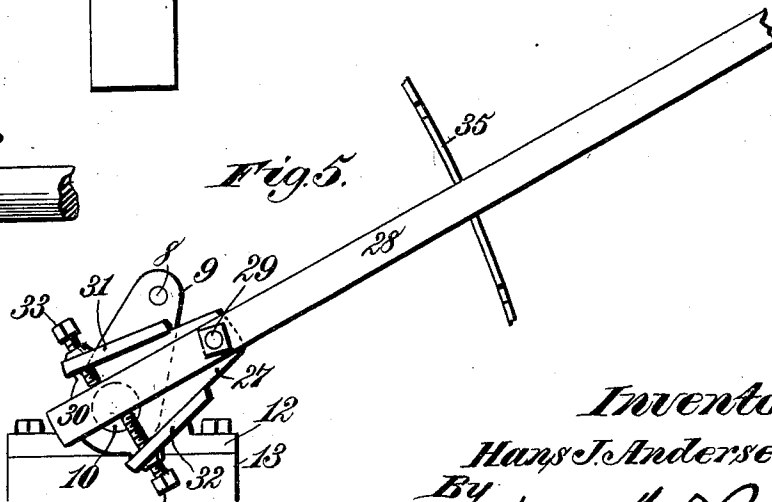

Fig. 5.



Witnesses.

Robert Grunth.

J. A. Rutherford.

Inventor.

Hans J. Andersen.

By Samuel Norris, Atty.

H. J. ANDERSEN.
COMBINED BAND AND CIRCULAR SAWMILL.

No. 470,964.

Patented Mar. 15, 1892.

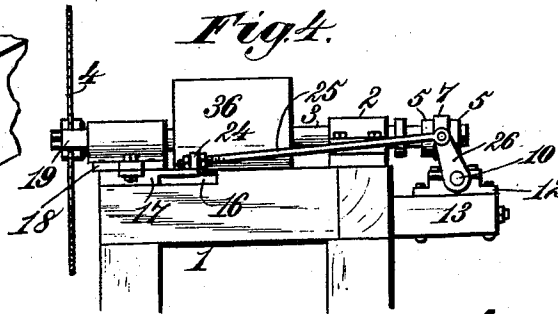
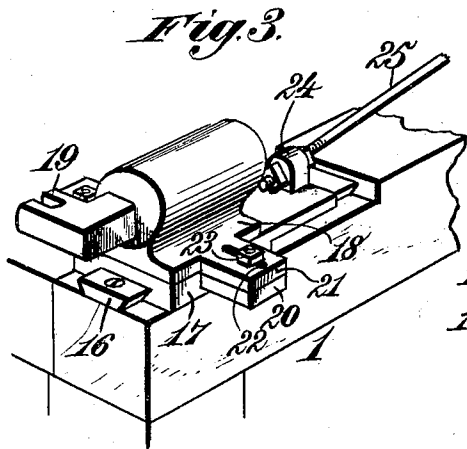
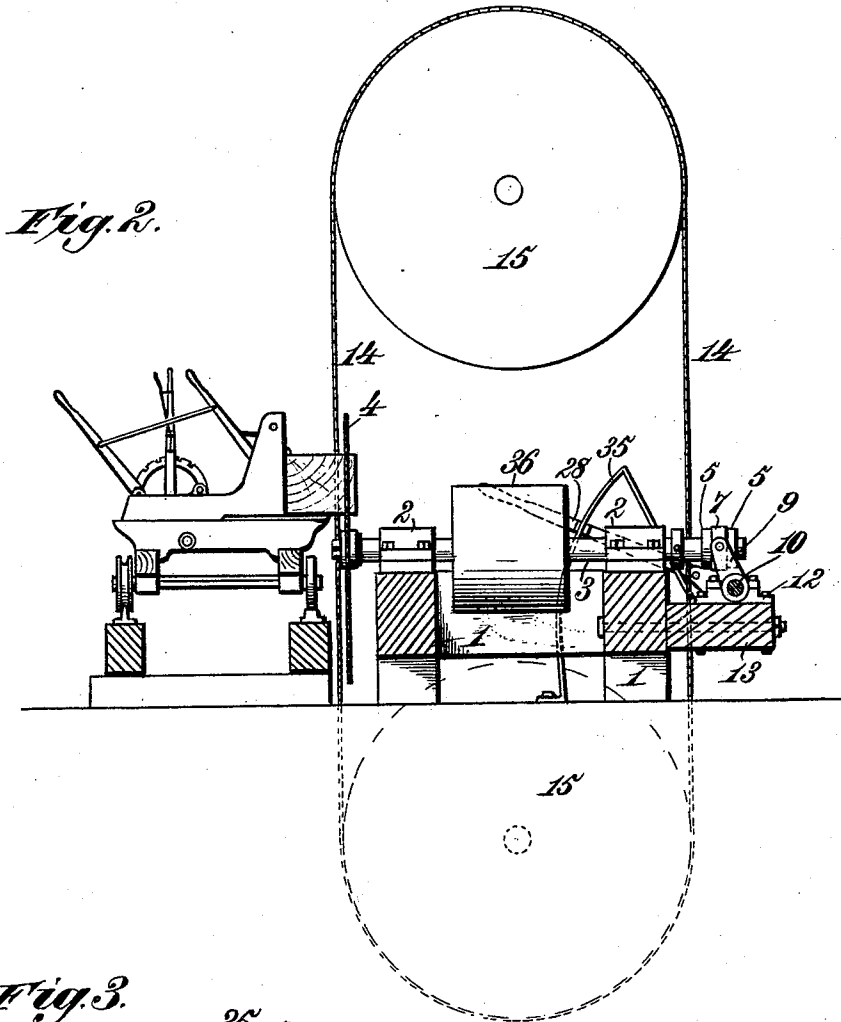

Witnesses:
Robert Sprutt,
J. A. Rutherford,

Inventor:
Hans J. Andersen.
By James L. Norris,
Atty.

UNITED STATES PATENT OFFICE.

HANS J. ANDERSEN, OF ST. CLOUD, MINNESOTA.

COMBINED BAND AND CIRCULAR SAW MILL.

SPECIFICATION forming part of Letters Patent No. 470,964, dated March 15, 1892.

Application filed August 17, 1891. Serial No. 402,910. (No model.)

To all whom it may concern:

Be it known that I, HANS J. ANDERSEN, a citizen of the United States, residing at St. Cloud, in the county of Stearns and State of Minnesota, have invented new and useful Improvements in Combined Band and Circular Saw Mills, of which the following is a specification.

This invention relates to that type of saw-mills wherein a band-saw and a circular saw operate conjointly to simultaneously sever two boards or planks of the desired thickness from the timber or saw-log.

The object of my invention is to provide novel means whereby the circular-saw arbor can be rapidly and conveniently adjusted lengthwise by the tail-sawyer for the purpose of cutting a board or plank of any desired thickness within certain limits, while the band-saw travels in an invariable path.

The invention also has for its object to provide novel means for supporting and adjusting the circular-saw guide on a stationary frame having boxes attached thereto, in which the circular-saw arbor rotates, and is susceptible of moving lengthwise for the purpose of simultaneously adjusting the saw-guide and saw-arbor to cut boards or planks of varying thickness.

To accomplish these objects my invention involves the features of construction and the combination or arrangement of devices hereinafter described and claimed, reference being made to the accompanying drawings, in which—

Figure 1 is a detail plan view of sufficient of a sawmill to illustrate my invention, the log-carriage and dogging mechanism being omitted. Fig. 2 is a vertical sectional view taken on the line *xx*, Fig. 1. Fig. 3 is a detail perspective view showing the sliding connection between the circular-saw guide and the stationary frame on which the circular-saw arbor is mounted. Fig. 4 is an end elevation omitting the log-carriage, dogging mechanism, and band-saw. Fig. 5 is a detail end elevation showing the connection between the shifting-lever and the rock-shaft which imparts lengthwise movement to the circular-saw arbor, and Fig. 6 is a detail sectional view of the rear end portion of the circular-saw arbor.

In order to enable those skilled in the art to make and use my invention, I will now describe the same in detail, referring to the drawings, wherein—

The numeral 1 indicates a stationary framework having front and rear boxes 2, in which is journaled the circular-saw arbor 3, carrying at its front end the circular saw 4 and having at its rear end a pair of collars 5, adjustably secured in a fixed position by means of set-screws or bolts 6, as more clearly exhibited in Fig. 6. A sleeve or collar 7 is loosely arranged on the saw-arbor between the set-collars 5, and to opposite sides of the sleeve or collar are attached by pins 8 the upper extremities of rocker arms or levers 9, having their lower ends rigidly attached to a horizontal rock-shaft 10, journaled in bearings 12 on a longitudinal timber or sill-piece 13 in such manner that when the shaft is rocked the rocker arms or levers serve to slide the saw-arbor 3 lengthwise in its boxes or bearings 2 for the purpose of adjusting the circular saw 4 relatively to the endless band-saw 14, which travels in an invariable path over the band-saw pulleys or wheels 15.

The stationary supporting-frame 1 is provided at one corner with a rigidly-attached dovetailed guide 16, with which engages a dovetailed base-plate 17, carrying a superimposed top plate 18, which is provided with a circular-saw guide 19 of ordinary form or construction. The dovetailed guide 16 runs in a direction parallel with the axis of the circular-saw arbor 3, and the base-plate 17 is provided with lateral flanges, as at 20, on which rest the lateral flanges 21 of the superimposed top plate 18. The flanges 21 of the top plate 18 are provided with slots 22, and are connected with the flanges 20 through the medium of clamping-bolts 23 for the purpose of adjusting the circular-saw guide 19 in a direction toward and from the axis of the circular-saw arbor to accommodate the circular saw. The base-plate 17 is provided with a lug 24, to which is attached one extremity of a connecting rod or link 25, which has its other extremity pivotally connected to the upper end portion of a rocker-arm 26, rigidly attached to the rock-shaft 10, so that when the rock-shaft is turned to move the circular-saw arbor 3 in the direction of its length the circular-

saw guide 19 will be adjusted simultaneously therewith.

The tail end of the rock-shaft 10 is provided with a rigidly-attached rocker arm or lever 27, to the upper end portion of which is secured the shifting-lever 28. The attachment between the lever 28 and the rocker arm or lever 27 is composed of a clamping-bolt 29, engaged with the shifting-lever at a point remote from its lower extremity in such manner that such shifting-lever is provided with what may be termed a "tail-piece" 30. The rocker arm or lever 27 is provided at its upper and lower edges with attached arms 31 and 32, provided, respectively, with set-screws or bolts 33 and 34, bearing against the upper and lower edges of the tail-piece 30 for the purpose of adjusting the angle of inclination of the shifting-lever 28, as occasion may demand, where one saw is inclined into the log and the other saw is inclined out of the log, as will more fully hereinafter appear. The shifting-lever is adapted to travel in relation to a quadrant-shaped locking-bar 35 for holding the lever in a fixed position after it has been adjusted, as occasion may demand.

The log-carriage and dogging mechanism, Fig. 2, may be of any construction suitable for the conditions required; but as such constitutes no part of my invention I do not deem it essential to further illustrate or describe the same.

The band-saw travels in an invariable path; but the circular saw is adjustable relatively to the band-saw through the medium of its lengthwise-movable arbor 3. The driving-pulley 36 of the circular-saw arbor is of suitable length, so that a driving-belt will remain in proper engagement with the pulley, notwithstanding the lengthwise sliding movements of the saw-arbor. The rock-shaft 10 extends in a plane at right angles to the longitudinal axis of the circular-saw arbor, and the shifting-lever 28 is thereby placed in a convenient position for the tail-sawyer to operate.

The construction and arrangement enable me to practically and efficiently operate a circular saw and a band-saw conjointly for the purpose of severing two boards simultaneously of any desired thickness within certain limits, while the band-saw can be operated alone by adjusting the circular saw rearward from the saw-line. The circular saw can be used alone by adjusting it into the saw-line of the band-saw, in which event the latter will run idle in the kerf produced by the circular saw.

The provision of the set-screws or bolts 33 and 34 for engaging the tail-piece 30 of the shifting-lever 28 is for the purpose of adjusting the shifting-rig to obtain uniform lumber from a saw having a tendency to incline into or out of the log and yet use the same notches in the quadrant-shaped locking-bar 35.

It is always desirable to make a circular

saw run straight; but several things sometimes prevent this. If a few of the teeth are a little out of square at the points, so that the corners next to the log are a little longer than the opposite corners, then the saw will tend to incline into the log and make too thick a board, while the one cut by the band-saw will be two thin, or if a saw when running strikes small gravel or sand a few of the corners of the teeth may be reduced a little, though not enough to spoil the saw for doing good work; but it will not run perfectly straight in the place intended. If the circular saw is cutting too thick a board, I move it bodily away from the log, and yet leave the shifting-lever 28 in its regular notch, which is accomplished by loosening the set-screw 34 and turning down the set-screw 33. This has the effect of changing the position of the saw-arbor bodily away from the log, and if the corners of the saw-teeth are injured on the other side, so that the saw tends to incline out of the log, by turning the set-screws 33 and 34 in the opposite direction a satisfactory result is obtained. On the other hand, if the circular saw is running perfect, but something has happened to the band-saw, so that it runs out of the log, the board it cuts would be too thin unless the circular saw is moved in its position bodily away from the band-saw, or if the band-saw is running into the log and making too thick a board then the circular-saw arbor is moved bodily and straight toward the log.

It is a fact thoroughly understood by all sawyers that no saw will any length of time run perfect in the line intended; but when one saw runs alone it does not make so much difference, as it will cut each board the same; but where two saws are working together it is impossible to make uniform lumber unless the saws are maintained the proper distance apart, which my invention accomplishes.

Having thus described my invention, what I claim is—

1. In a sawmill having a band-saw and a circular saw, the combination of a stationary frame having boxes or bearings in which the circular-saw arbor is susceptible of sliding lengthwise in a plane at right angles to the plane in which the band-saw travels, with a rock-shaft extending at right angles to the axis of the circular-saw arbor, a shifting-lever for the rock-shaft, and loose connections between the circular-saw arbor and the rock-shaft for sliding the saw-arbor lengthwise, substantially as described.

2. In a sawmill, the combination, with a band and a circular saw, of a stationary frame having boxes or bearings in which the circular-saw arbor is journaled to move lengthwise in a plane at right angles to the plane in which the band-saw travels, a rock-shaft extending at right angles to the axis of the saw-arbor and provided with rocker arms or levers, a shifting-lever for the rock-shaft, and a loose connection between the rocker arms or levers

and the circular-saw arbor for sliding the latter lengthwise when the rock-shaft is turned, substantially as described.

3. In a sawmill having a band-saw and a circular saw, the combination, with a stationary frame having boxes or bearings in which the circular-saw arbor is journaled to move lengthwise in a plane at right angles to the plane in which the band-saw travels, of a pair of set-collars mounted on the rear end portion of the saw-arbor, a non-rotating sleeve or collar arranged between the set-collars, a rock-shaft having rocker arms or levers secured to the non-rotating sleeve or collar, and a shifting-lever for turning the rock-shaft to move the circular-saw arbor lengthwise in its boxes or bearings on the stationary frame, substantially as described.

4. In a sawmill, the combination, with a stationary frame and a circular-saw arbor adapted to move lengthwise in boxes or bearings thereupon, of a dovetailed guide on the frame, a base-plate engaging the guide, a superimposed top plate carrying a circular-saw guide, a rock-shaft having rocker-arms loosely connected with the circular-saw arbor and with the said base-plate, and a shifting-lever for turning the rock-shaft to simultaneously shift the circular-saw arbor and the circular-saw guide, substantially as described.

5. In a sawmill, the combination, with a

frame having boxes or bearings, of a circular-saw arbor movable lengthwise in the boxes or bearings, a rock-shaft loosely connected with the circular-saw arbor and having its tail end provided with a rocker arm or lever, a shifting-lever having a clamping connection with the rocker arm or lever and provided with a tail-piece, and upper and lower set-screws or bolts acting against the opposite edges of the tail-piece of the shifting-lever, substantially as described.

6. In a sawmill, the combination, with a frame having boxes or bearings, of a circular-saw arbor movable lengthwise in the boxes or bearings, a rock-shaft loosely connected with the circular-saw arbor for moving the latter lengthwise, a rocker arm or lever mounted on the tail end of the rock-shaft and provided with projecting arms, each having a set-screw or bolt, and a shifting-lever clamped to the said rocker arm or lever and provided with a tail-piece extending between the inner extremities of the set-screws or bolts, substantially as described.

In testimony whereof I have hereunto set my hand and affixed my seal in presence of two subscribing witnesses.

HANS J. ANDERSEN. [L. S.]

Witnesses:

M. D. TAYLOR,
DANIEL T. CALHOUN.