

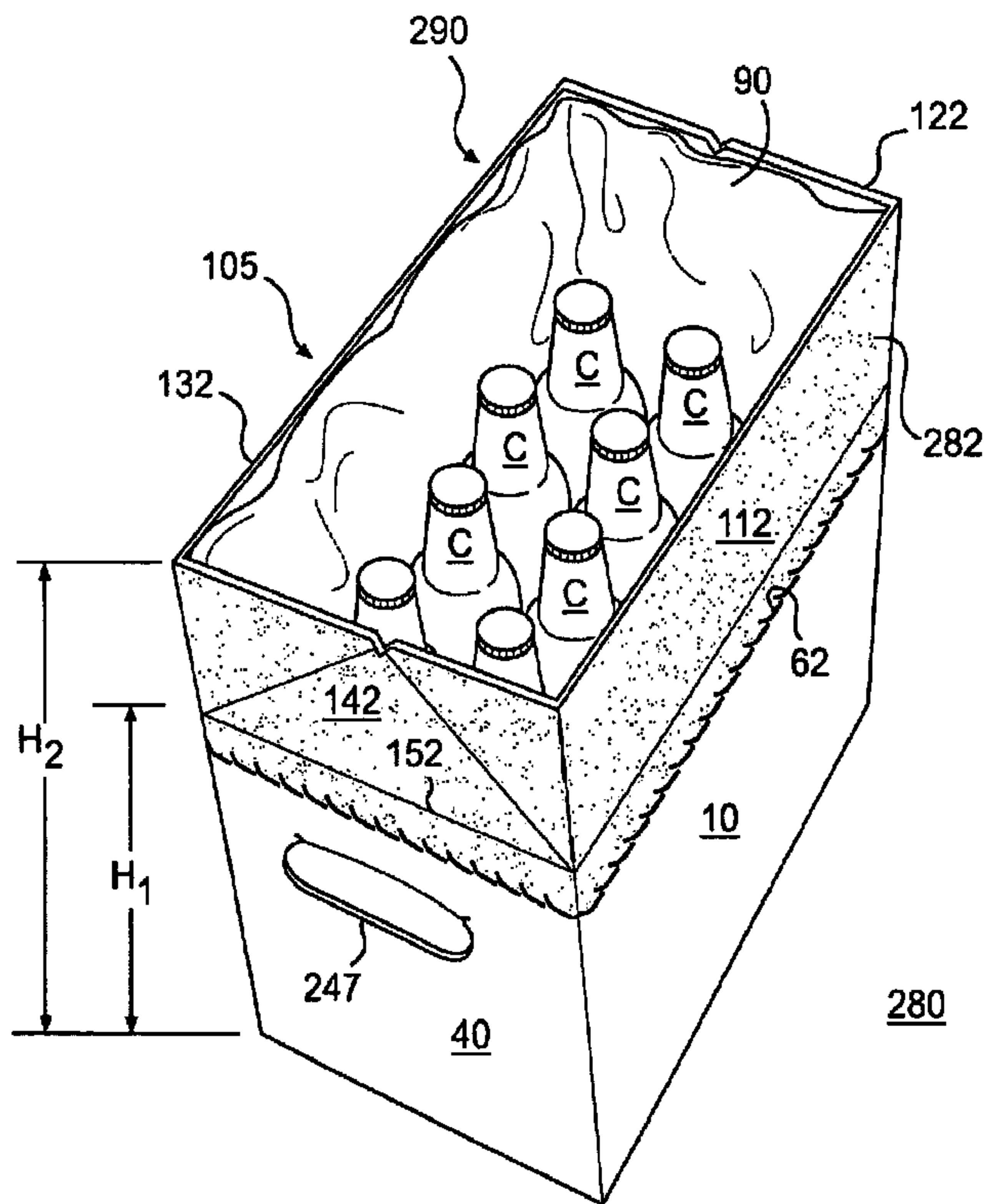

(86) Date de dépôt PCT/PCT Filing Date: 2007/05/18
 (87) Date publication PCT/PCT Publication Date: 2007/11/29
 (45) Date de délivrance/Issue Date: 2012/07/24
 (85) Entrée phase nationale/National Entry: 2008/10/31
 (86) N° demande PCT/PCT Application No.: US 2007/011906
 (87) N° publication PCT/PCT Publication No.: 2007/136750
 (30) Priorité/Priority: 2006/05/18 (US60/801,525)

(51) Cl.Int./Int.Cl. *B65D 5/60* (2006.01),
B65D 5/00 (2006.01), *B65D 5/06* (2006.01),
B65D 5/08 (2006.01), *B65D 5/10* (2006.01),
B65D 5/40 (2006.01), *B65D 5/468* (2006.01),
B65D 5/54 (2006.01), *F25D 3/08* (2006.01)
 (72) Inventeurs/Inventors:
 BRAND, KIRSTEN LAURA, US;
 GOMES, JEAN-MANUEL, US
 (73) Propriétaire/Owner:
 GRAPHIC PACKAGING INTERNATIONAL, INC., US
 (74) Agent: MACRAE & CO.

(54) Titre : CARTONS POURVUS DE RECIPIENTS ETANCHES AUX LIQUIDES
 (54) Title: CARTONS WITH LIQUID-TIGHT RECEPTACLES



(57) Abrégé/Abstract:

Carton includes a liquid-tight vessel (90, 390, 790) that lines the interior volume of the carton (280, 580, 880). The carton may have selected sections reinforced by one or more reinforcing blanks (105, 205, 405, 505, 805).



(12) INTERNATIONAL APPLICATION PUBLISHED UNDER THE PATENT COOPERATION TREATY (PCT)

(19) World Intellectual Property Organization
International Bureau(43) International Publication Date
29 November 2007 (29.11.2007)

PCT

(10) International Publication Number
WO 2007/136750 A3

(51) International Patent Classification:

B65D 5/60 (2006.01) *B65D 5/468* (2006.01)
B65D 5/08 (2006.01) *B65D 5/54* (2006.01)
B65D 5/06 (2006.01) *B65D 5/00* (2006.01)
B65D 5/10 (2006.01) *F25D 3/08* (2006.01)
B65D 5/40 (2006.01)

(21) International Application Number:

PCT/US2007/011906

(22) International Filing Date: 18 May 2007 (18.05.2007)

(25) Filing Language: English

(26) Publication Language: English

(30) Priority Data:

60/801,525 18 May 2006 (18.05.2006) US

(71) Applicant: **GRAPHIC PACKAGING INTERNATIONAL, INC.** [US/US]; 814 Livingston Court, Marietta, GA 30067 (US).(72) Inventors: **BRAND, Kirsten, Laura**; 3860 Manor House Drive, Marietta, GA 30062 (US). **GOMES, Jean-Manuel**; 2699 Shadow Bluff Drive, Marietta, GA 30062 (US).(74) Agents: **ISAF, Louis, T. et al.**; Womble Carlyle Sandridge & Rice, PLLC, P.O. box 7037, Atlanta, GA 30357-0037 (US).(81) Designated States (*unless otherwise indicated, for every kind of national protection available*): AE, AG, AL, AM, AT, AU, AZ, BA, BB, BG, BH, BR, BW, BY, BZ, CA, CH, CN, CO, CR, CU, CZ, DE, DK, DM, DZ, EC, EE, EG, ES, FI, GB, GD, GE, GH, GM, GT, HN, HR, HU, ID, IL, IN, IS, JP, KE, KG, KM, KN, KP, KR, KZ, LA, LC, LK, LR, LS, LT, LU, LY, MA, MD, ME, MG, MK, MN, MW, MX, MY, MZ, NA, NG, NI, NO, NZ, OM, PG, PH, PL, PT, RO, RS, RU, SC, SD, SE, SG, SK, SL, SM, SV, SY, TJ, TM, TN, TR, TT, TZ, UA, UG, US, UZ, VC, VN, ZA, ZM, ZW.(84) Designated States (*unless otherwise indicated, for every kind of regional protection available*): ARIPO (BW, GH, GM, KE, LS, MW, MZ, NA, SD, SL, SZ, TZ, UG, ZM, ZW), Eurasian (AM, AZ, BY, KG, KZ, MD, RU, TJ, TM), European (AT, BE, BG, CH, CY, CZ, DE, DK, EE, ES, FI, FR, GB, GR, HU, IE, IS, IT, LT, LU, LV, MC, MT, NL, PL,

[Continued on next page]

(54) Title: CARTONS WITH LIQUID-TIGHT RECEPTACLES

(57) Abstract: Carton includes a liquid-tight vessel (90, 390, 790) that lines the interior volume of the carton (280, 580, 880). The carton may have selected sections reinforced by one or more reinforcing blanks (105, 205, 405, 505, 805).

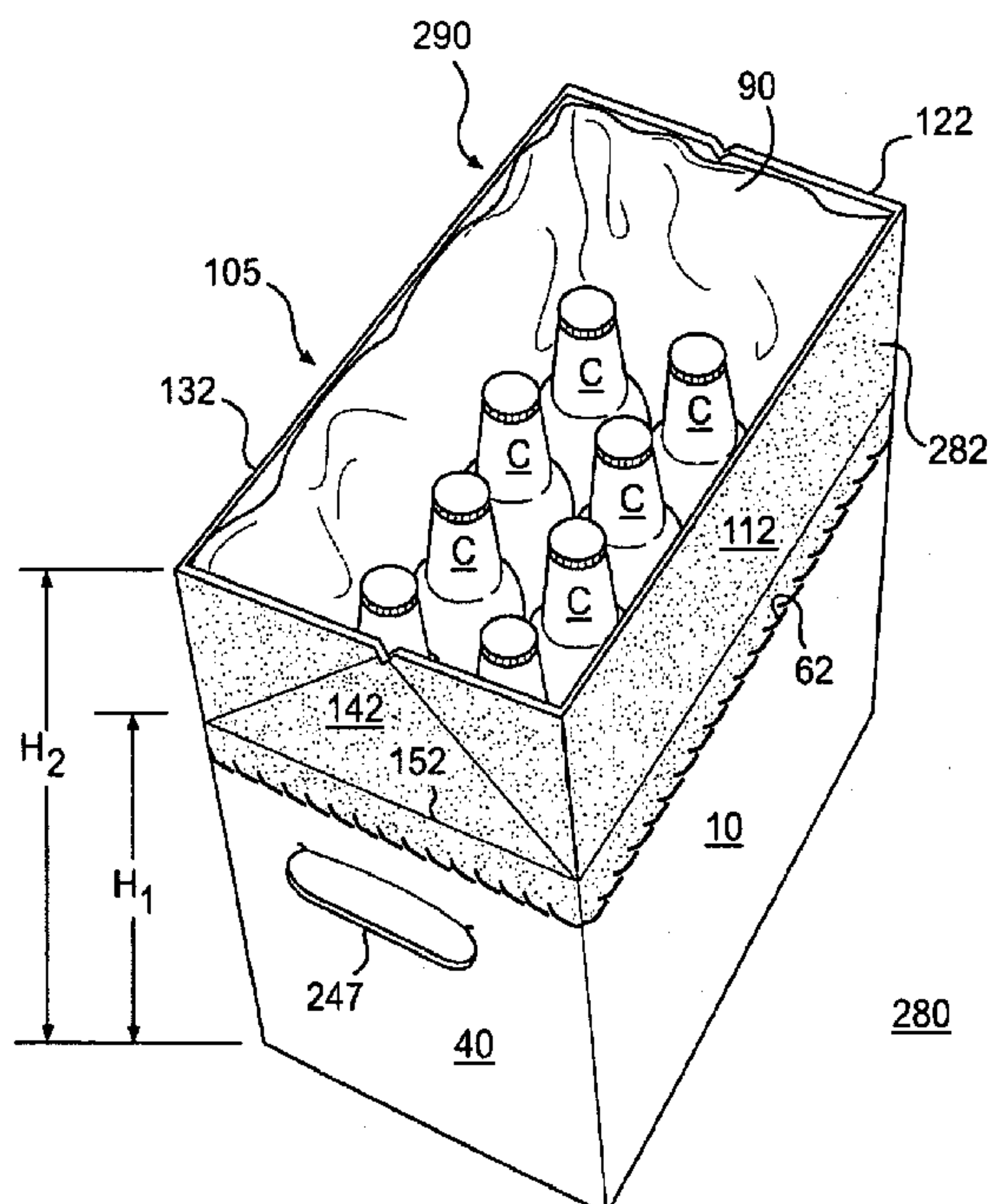

WO 2007/136750 A3

WO 2007/136750 A3



PT, RO, SE, SI, SK, TR), OAPI (BF, BJ, CF, CG, CI, CM, GA, GN, GQ, GW, ML, MR, NE, SN, TD, TG).

— *before the expiration of the time limit for amending the claims and to be republished in the event of receipt of amendments*

Published:

— *with international search report*

(88) Date of publication of the international search report:
3 April 2008

CARTONS WITH LIQUID-TIGHT RECEPTACLES

BACKGROUND

[0001] Dispensing cartons are known. Conventional dispensing cartons may have a top panel with a dispensing feature formed therein. Such cartons may be used to contain articles such as beverage containers, for example, that are dispensable through the top panel or through another panel when the carton is opened. Typically, conventional cartons must be refrigerated in order to keep the enclosed containers cool. When the cartons are no longer refrigerated, such as when the carton is removed from the refrigerator to dispense the containers, the containers may become undesirably warm. The containers must then be refrigerated again or otherwise cooled. Further, the dispensing features included in conventional cartons may render the cartons incapable of being securely reclosed once opened. Articles retained within the carton may therefore inadvertently fall out of the carton once the carton has been opened.

[0002] Conventional cartons are typically formed from a single ply of paperboard or similar material. Carrying handles may be formed in one or more panels of the carton and used to carry the carton. Because cartons are often used to carry relatively heavy articles, such as beverage containers, the strength of the handles or other sections of the cartons must be increased in order to accommodate the carton load. A conventional method for increasing the load-bearing capacity of a paperboard carton is to produce the carton from a blank of a different, stronger paperboard material, or to produce the blank from the same carton material but having greater thickness or caliper. Such conventional methods typically increase the costs associated with manufacturing the carton, with the material costs of manufacture generally increasing according to the cost of increasing the strength and/or thickness of the entire blank. Some sections of the blank, however, may not be load-bearing, and the additional costs associated with increasing the strength of non-load bearing sections of the blank are wasted.

SUMMARY

[0003] According to a first embodiment of the invention, a carton comprises a bottom closure, a first side panel, a second side panel, a first end panel, and a second end panel, wherein the side and end panels and the bottom closure define in part an interior volume of the carton. A liquid-tight vessel is attached to at least a portion of

the interior surface of the carton and provides a liquid-tight lining for at least a portion of the interior volume of the carton.

[0004] According to an aspect of the first embodiment, a top of the carton can be opened and ice, cold water, additional containers, and/or other articles can be placed in the carton through the opened top end. The interior volume of the carton can be used to retain liquids, such as water resulting from melting ice, condensation, other liquids, and articles such as, for example, refuse, particulate matter, etc.

[0005] According to another aspect of the invention, a carton can be formed from a multi-ply blank comprising a major blank and one or more minor blanks. The minor blanks may be configured to render the carton multi-ply at selected sections. A minor blank may be used, for example, to reinforce the major blank so as to increase the strength and/or load-bearing capacity of the multi-ply carton. The minor blank can be configured to reinforce the major blank at any number of desired locations. Selected reinforcement of specific areas of the major blank can produce a high strength carton having a high load-bearing capacity while using relatively small amounts of paperboard or other materials of construction.

[0006] According to another aspect of the invention, the minor blank can be at least partially unfolded to place the carton in an expanded configuration. The height of the carton interior, and concomitantly the interior volume of the carton, are increased in the expanded configuration. The increased interior volume of the carton can be used to accommodate items such as, for example, additional containers or ice within the carton. The liquid-tight vessel can be adhered to the carton interior surface adjacent to an upper edge of the minor blank so that substantially all of the interior volume of the carton is liquid-tight.

[0007] According to one aspect of the present invention there is provided an enclosed carton having an interior surface, the carton being constructed from a major blank and at least one minor blank adhered to the major blank, and the at least one minor blank overlapping less than an entirety of the major blank, the major blank having top end flaps at a first marginal area and bottom end flaps at a second marginal area, the carton comprising a top closure formed by the top end flaps of the major blank at the first marginal area; a bottom closure formed by the bottom end flaps of the major blank at the second marginal area; a first side panel; a second side panel; a first end panel; a second end panel, wherein the side and end panels, the top closure, and the bottom closure enclose and define in part an interior volume of the carton; and a liquid-tight vessel attached to at least a portion of the interior surface and lining at least a portion of the interior volume of the carton; wherein the at least

one minor blank comprises an upper minor blank adhered to the major blank adjacent to the top closure and a lower minor blank adhered to the major blank at the bottom closure, the upper minor blank has top end flaps that overlap the top end flaps of the major blank, and the lower minor blank has bottom end flaps that overlap the bottom end flaps of the major blank.

[0008] According to a further aspect of the present invention there is provided an enclosed multi-ply carton constructed from a major blank and at least one minor blank and having an interior surface, the major blank having top end flaps at a first marginal area and bottom end flaps at a second marginal area, the carton comprising a top closure formed by the top end flaps of the major blank at the first marginal area; a bottom closure formed by the bottom end flaps of the major blank at the second marginal area; a first side panel; a second side panel; a first end panel; a second end panel, wherein the side and end panels, the top closure, and the bottom closure enclose and define in part an interior volume of the carton; and a liquid-tight vessel attached to at least a portion of the interior surface and lining at least a portion of the interior volume of the carton, wherein the at least one minor blank overlapping less than the entirety of the first side panel, the second side panel, the first end panel, and the second end panel, the at least one minor blank is adhered to at least two of the first side panel, the second side panel, the first end panel, and the second end panel, and the at least one minor blank comprises an upper minor blank adhered to the major blank adjacent to the top closure and a lower minor blank adhered to the major blank at the bottom closure, the upper minor blank has top end flaps that overlap the top end flaps of the major blank, and the lower minor blank has bottom end flaps that overlap the bottom end flaps of the major blank.

[0008.1] According to another aspect of the present invention there is provided an article, comprising a multi-ply blank comprising at least a major blank and at least one minor blank adhered to the major blank, a first side panel, a second side panel, a first end panel, and a second end panel comprising sections of the major blank; the major blank including top end flaps at a first marginal area and bottom end flaps at a second marginal area; the minor blank is adhered to at least two of the first side panel, the second side panel, the first end panel, and the second end panel; the minor blank overlapping less than the entirety of the first side panel, the second side panel, the first end panel, or the second end panel; a bottom closure formed by at least partially overlapping the bottom end flaps at the second marginal area; a top closure formed by at least partially overlapping the top end flaps at the first marginal area; a first side

panel; a second side panel; a first end panel; a second end panel; and a liquid-tight vessel adhered to at least a portion of an interior surface of the blank, the first and second side panels, the first and second end panels, and the top closure, and the bottom closure enclose and define at least in part an interior of the article, the first side panel; wherein the at least one minor blank an upper minor blank adhered to the major blank adjacent to the top closure and a lower minor blank adhered to the major blank at the bottom closure, the upper minor blank has top end flaps that overlap the top end flaps of the major blank, and the lower minor blank has bottom end flaps that overlap the bottom end flaps of the major blank.

[0008.2] According to a still further aspect of the present invention there is provided a method of utilizing a multi-ply carton constructed from a major blank and at least one minor blank and having an interior surface, the major blank having top end flaps at a first marginal area and bottom end flaps at a second marginal area, the method comprising: providing a carton, comprising: a bottom closure formed by the bottom end flaps of the major blank at the second marginal area; a top closure formed by the top end flaps of the major blank at the first marginal area; a first side panel; a second side panel; a first end panel; a second end panel, wherein the side and end panels, the top closure, and the bottom closure enclose and define in part an interior volume of the carton; and a liquid-tight vessel attached to at least a portion of the interior surface and lining at least a portion of the interior volume of the carton; the at least one minor blank is adhered to at least two of the first side panel, the second side panel, the first end panel, and the second end panel; the minor blank overlapping less than the entirety of the first side panel, the second side panel, the first end panel, or the second end panel, and the at least one minor blank comprises an upper minor blank adhered to the major blank adjacent to the top closure and a lower minor blank adhered to the major blank at the bottom closure, the upper minor blank has top end flaps that overlap the top end flaps of the major blank, and the lower minor blank has bottom end flaps that overlap the bottom end flaps of the major blank; closing the top closure of the carton by inwardly folding the top end flaps that are overlapped by a respective top end flap of the upper minor blank; opening the top closure of the carton; and expanding the interior volume of the carton by at least partially unfolding the at least one minor blank to define an upper portion of the at least one minor blank.

[0009] Other aspects, features, and details of the present invention can be more completely understood by reference to the following detailed description, taken in conjunction with the drawings and from the appended claims.

BRIEF DESCRIPTION OF THE DRAWING FIGURES

- [0010] According to common practice, the various features of the drawings discussed below are not necessarily drawn to scale. Dimensions of various features and elements in the drawings may be expanded or reduced to more clearly illustrate the embodiments of the invention.
- [0011] FIG. 1A is a plan view of a multi-ply blank used to form a carton according to a first embodiment of the invention.
- [0012] FIG. 1B is a plan view of a major blank of the multi-ply blank illustrated in FIG. 1A.
- [0013] FIG. 1C is a plan view of a first minor blank of the multi-ply blank illustrated in FIG. 1A.
- [0014] FIG. 1D is a plan view of a second minor blank of the multi-ply blank illustrated in FIG. 1A.
- [0015] FIG. 1E illustrates application of a liquid-tight vessel to the blank of FIG. 1A.

- [0016] FIG. 2 illustrates an erection step of the first carton embodiment.
- [0017] FIG. 3 illustrates an erection step of the first carton embodiment.
- [0018] FIG. 4 illustrates an erection step of the first carton embodiment.
- [0019] FIG. 5 illustrates an erection step of the first carton embodiment.
- [0020] FIG. 6 illustrates an erection step of the first carton embodiment.
- [0021] FIG. 7 illustrates the erected first carton embodiment with containers accommodated therein.
- [0022] FIG. 8 illustrates the first carton embodiment with the top of the carton opened.
- [0023] FIG. 9 illustrates the first carton embodiment opened and with ice poured over the carton contents.
- [0024] FIG. 10 illustrates the first carton embodiment after closing the top of the carton with a detached lid section.
- [0025] FIG. 11A is a plan view of a multi-ply blank used to form a carton according to a second embodiment of the invention.
- [0026] FIG. 11B is a plan view of a major blank of the multi-ply blank illustrated in FIG. 11A.
- [0027] FIG. 11C is a plan view of a first minor blank of the multi-ply blank illustrated in FIG. 11A.
- [0028] FIG. 11D is a plan view of a second minor blank of the multi-ply blank illustrated in FIG. 11A.
- [0029] FIG. 11E illustrates application of a liquid-tight vessel to the multi-ply blank of FIG. 11A.
- [0030] FIG. 12 illustrates an erection step in which the blank of FIG. 11A is formed into the carton according to the second embodiment.
- [0031] FIG. 13 illustrates an erection step of the second carton embodiment.

[0032] FIG. 14 illustrates the erected second carton embodiment with containers accommodated therein.

[0033] FIG. 15 illustrates the second carton embodiment with the top of the carton being opened.

[0034] FIG. 16A is a plan view of a major blank of a multi-ply blank according to a third embodiment of the invention.

[0035] FIG. 16B is a plan view of a minor blank of the multi-ply blank according to the third embodiment of the invention.

[0036] FIG. 16C illustrates the multi-ply blank according to the third embodiment of the invention with a liquid-tight vessel applied thereto.

[0037] FIG. 17 illustrates a carton formed from the multi-ply blank of FIG. 16C according to the third embodiment.

DETAILED DESCRIPTION

[0038] The first embodiment of the invention relates to a carton suitable for storing and dispensing articles such as, for example, beverage containers. The carton provides a receptacle suitable for accommodating, for example, liquids, ice, or other coolants in the carton. The receptacle may be, for example, liquid-tight. In one exemplary embodiment, ice can be added to the opened carton to cool articles held within the carton. As the ice melts, all or a part of the resultant runoff water may be held within the liquid-tight receptacle. One or more reinforcing minor blanks can be included, for example, to increase the strength of selected portions of the carton so as to increase the load-bearing capacity of the carton, to allow for an increase in an interior volume of the carton, to provide a reclosable lid, or to provide other advantages.

[0039] Articles accommodated within the present carton embodiments can include containers such as, for example, petaloid bottle containers, beverage cans, glass or plastic bottles, or other containers such as, for example, those used in the packaging of foodstuffs. For the purposes of illustration and not for the purpose of limiting the scope of the present invention, the following detailed

description describes beverage bottles as disposed within the illustrated cartons. In this specification, the terms “side,” “bottom,” “lower,” “upper” and “top” indicate orientations determined in relation to fully erected, upright cartons. In this specification, the terms “end” and “side” are used for ease of reference, and do not imply relative sizes of panels or flaps.

[0040] FIG. 1A is a plan view of a multi-ply blank 8 used to form a carton 280 (illustrated in FIG. 7) according to the first embodiment of the invention. The multi-ply blank 8 is formed from a major blank 5 and upper and lower minor blanks 105, 205, respectively, that are adhered, laminated, or otherwise joined to the interior side of the major blank 5. The interior or underside surface of the major blank 5, with the minor blanks 105, 205 adhered thereto, is visible in FIG. 1A. In the drawing figures of this specification, the surface of the minor blanks 105, 205 are shaded with stippling solely to distinguish the minor blanks 105, 205 from the major blank 5, which is not stippled. In the illustrated embodiment, the minor blanks 105, 205 are adhered to the interior side of the major blank 5, although they may be adhered to the exterior or print side.

[0041] The multi-ply blank 8 is “multi-ply” in that the joined blank plies 5, 105, 205 comprising the multi-ply blank 8 include substantial overlapping portions. Also, a majority of the overlapping surfaces of the major blank 5 and the minor blank plies 105, 205 may be adhered adjacent to one another. The minor blanks 105, 205 have different perimeters or “footprints” and need not overlap at all points with the major blank 5. The individual plies comprising the multi-ply blank 8 are illustrated in FIGS. 1B-1D. FIG. 1B is a plan view of the exterior or print side of the major blank 5, FIG. 1C is a plan view of the upper minor blank 105, and FIG. 1D is a plan view of the lower minor blank 205.

[0042] Referring to FIG. 1B, the major blank 5 comprises a first side panel 10, a first end panel 20 foldably connected to the first side panel 10 at a transverse fold line 21, a second side panel 30 foldably connected to the first end panel 20 at a transverse fold line 31, and a second end panel 40 foldably connected to the

second side panel **30** at a transverse fold line **41**. An adhesive flap **16** may be foldably connected to the first side panel **10** at a transverse fold line **18**.

[0043] Still referring to **FIG. 1B**, a first side top flap **12** of the major blank **5** is foldably connected to the first side panel **10** at a cut-crease longitudinal fold line **52** and a first side bottom flap **14** is foldably connected to the first side panel **10** at a longitudinal fold line **54**. A first end top flap **22** is foldably connected to the first end panel **20** at the longitudinal fold line **52** and a first end bottom flap **24** is foldably connected to the first end panel **20** at the longitudinal fold line **54**. A second side top flap **32** is foldably connected to the second side panel **30** at the longitudinal fold line **52** and a second side bottom flap **34** is foldably connected to the second side panel **30** at the longitudinal fold line **54**. A second end top flap **42** is foldably connected to the second end panel **40** at the longitudinal fold line **52** and a second end bottom flap **44** is foldably connected to the second end panel **40** at the longitudinal fold line **54**. The longitudinal fold lines **52**, **54** may be straight fold lines, or may be offset at one or more locations to account for, for example, blank thickness. The top flaps **12**, **22**, **32**, **42** extend along a first or upper marginal area of the major blank **5**. The bottom flaps **14**, **24**, **34**, **44** extend along a second or lower marginal area of the major blank **5**. As shown in **FIG. 1B**, the longitudinal fold line **54** may be interrupted at the transverse fold lines **21**, **31**, **41**.

[0044] A handle feature **25** is formed in the first end panel **20** and a similar handle feature **45** is formed in the second end panel **40**. The first end top flap **22** may include oblique fold or crease lines **26**, **28** extending from the longitudinal fold line **52** to a top edge of the first top end flap **22**. The second end top flap **42** may include oblique fold or crease lines **46**, **48** extending from the longitudinal fold line **52** to the top edge of the second top end flap **42**. The oblique fold lines **26**, **28**, **46**, **48** facilitate closure of a top of the major blank **5** during erection of the carton **280** (**FIG. 7**).

[0045] A longitudinal tear strip 60 is defined by spaced tear lines 61, 62 extending the length of the major blank 5 through the panels 10, 20, 30, 40. The tear strip 60 allows a top of the carton 280 to be opened, as discussed in further detail below.

[0046] FIG. 1C illustrates the side of the upper minor blank 105 that is adhered to the interior or underside surface of the major blank 5 illustrated in FIG. 1B. The opposite side of the upper minor blank 105 faces the interior of the carton 280 (FIG. 7) formed from the multi-ply blank 8. Overlapping elements in the blanks 5, 105 are indicated by similar reference numbers, with reference numbers in the upper minor blank 105 being preceded by a "1."

[0047] Referring to FIG. 1C, the upper minor blank 105 comprises a first side panel 110, a first end panel 120 foldably connected to the first side panel 110 at a transverse fold line 121, a second side panel 130 foldably connected to the first end panel 120 at a transverse fold line 131, and a second end panel 140 foldably connected to the second side panel 130 at a transverse fold line 141. An adhesive flap 116 may be foldably connected to the first side panel 110 at a transverse fold line 118. A first side top flap 112 is foldably connected to the first side panel 110 at a longitudinal fold line 152. A first end top flap 122 is foldably connected to the first end panel 120 at the longitudinal fold line 152. A second side top flap 132 is foldably connected to the second side panel 130 at the longitudinal fold line 152. A second end top flap 142 is foldably connected to the second end panel 140 at the longitudinal fold line 152. The first side top flap 112 may be foldably connected to the adhesive flap 116 at a transverse cut-space fold line 153 and to the first end top flap 122 at a transverse cut-space fold line 123. The second side top flap 132 may be foldably connected to the first end top flap 122 at a transverse cut-space fold line 133 and to the second end top flap 142 at a transverse cut-space fold line 143. The top flaps 112, 122, 132, 142 extend along an upper marginal area of the upper minor blank 105. In the multi-ply blank 8, the top flaps 112, 122, 132, 142 at least partially overlap the top flaps 12, 22, 32, 42 in the major blank 5 (FIG. 1B).

[0048] Still referring to **FIG. 1C**, a handle feature **125** is formed in the first end panel **120** and a similar handle feature **145** is formed in the second end panel **140**. In the multi-ply blank **8**, the handle features **125**, **145** overlap and cooperate with the handle features **25**, **45**, respectively, in the major blank **5** (**FIG. 1B**). The first end top flap **122** may include oblique fold or crease lines **126**, **128** extending from the longitudinal fold line **152** to a top edge of the first end top flap **122**. The second end top flap **142** may include oblique fold or crease lines **146**, **148** extending from the longitudinal fold line **152** to the top edge of the second end top flap **142**. The oblique fold lines **126**, **128**, **146**, **148** facilitate closure of a top of the upper minor blank **105** during erection of the carton **280** (**FIG. 7**) and facilitate expansion of the carton interior carton volume (**FIG. 8**).

[0049] **FIG. 1D** illustrates the side of the lower minor blank **205** that is adhered to the major blank **5** illustrated in **FIG. 1B**. The opposite side of the lower minor blank **205** faces the interior of the carton **280** (**FIG. 7**). Overlapping features in the blanks **5**, **205** are indicated by similar reference numbers, with reference numbers in the lower minor blank **205** preceded by a "2."

[0050] Referring to **FIG. 1D**, the lower minor blank **205** comprises a first side panel **210**, a first end panel **220** foldably connected to the first side panel **210** at a transverse fold line **221**, a second side panel **230** foldably connected to the first end panel **220** at a transverse fold line **231**, and a second end panel **240** foldably connected to the second side panel **230** at a transverse fold line **241**. An adhesive flap **216** may be foldably connected to the first side panel **210** at a transverse fold line **218**. A first side bottom flap **214** is foldably connected to the first side panel **210** at a longitudinal fold line **254**. A first end bottom flap **224** is foldably connected to the first end panel **220** at the longitudinal fold line **254**. A second side bottom flap **234** is foldably connected to the second side panel **230** at the longitudinal fold line **254**. A second end bottom flap **244** is foldably connected to the second end panel **240** at the longitudinal fold line **254**. The bottom flaps **114**, **224**, **234**, **244** extend along a lower marginal area of the lower minor blank

205. The bottom flaps **214, 224, 234, 244** at least partially overlap the bottom flaps **14, 24, 34, 44**, respectively, in the major blank **5** (**FIG. 1B**).

[0051] Referring to **FIGS. 1A-1D**, the multi-ply blank **8** may be constructed by adhering the upper minor blank **105** and the lower minor blank **205** to the interior side of the major blank **5**, as shown in **FIG. 1A**. Each of the panels **110, 120, 130, 140** of the upper minor blank **105** may be adhered to a corresponding panel **10, 20, 30, 40**, respectively, of the major blank **5**, in the crosshatched area **108** shown in **FIG. 1C**. The upper minor blank **105** may be adhered to the major blank **5**, for example, below the tear strip **60**. The lower minor blank **205** can be adhered to the major blank **5** so that each panel or flap **210, 220, 230, 240, 216, 214, 224, 234, 244** of the lower minor blank **205** is adhered to a corresponding panel or flap **10, 20, 30, 40, 16, 14, 24, 34, 44**, respectively, of the major blank **5**. Glue strips, applied hot melt glue, lamination processes, or other adhesives and means can be used to adhere the major and minor blanks **5, 105, 205** together.

[0052] Referring to **FIG. 1E**, a liquid-tight receptacle or vessel **90** is placed on the interior side of the multi-ply blank **8**. The liquid-tight vessel, or "bag" **90** has sealed portions **92, 96** and an open top portion **94** through which articles can be placed in the vessel. The liquid-tight vessel **90** can be adhered to, for example, one or more locations of the panels **10, 110, 210, 20, 120, 220, 30, 130, 230, 40, 140, 240**. In one embodiment, it is sufficient to adhere the liquid-tight vessel **90** to the upper minor blank **105**, such as at an upper edge of the blank **105**. The liquid-tight vessel **90** may be joined to the blank **8** so that when the blank **8** is opened to a generally tubular form, the open top portion **94** of the liquid-tight vessel **90** is supported in an open position by its adherence to the interior surface of the blank **8**. The liquid-tight vessel **90** can be formed from, for example, any liquid-tight material. For example, a flexible liquid-tight material such as plastic may be used to form the vessel **90**. In the illustrated exemplary embodiment, the vessel **90** is a plastic bag.

[0053] An exemplary method of erection of the multi-ply blank 8 and liquid-tight vessel 90 into the carton 280 and loading of the carton will now be discussed with reference to FIGS. 1A-7.

[0054] Referring to FIGS. 1A-1E and specifically to FIG. 2, the multi-ply blank 8 is folded about the transverse fold lines 21, 41 in the major blank 5 and about the corresponding transverse fold lines 121, 221, 141, 241 in the minor blanks 105, 205 so that the exterior side of the adhesive flap 16 of the major blank 5 is adhered to the interior sides of the second end panels 40, 140, 240 in the blanks 5, 105, 205, respectively. Also, the exterior side of the adhesive flap 116 (FIG. 1C) of the upper minor blank 105 is adhered to the interior side of the second end top flap 142. Folding of the blank 8 as shown in FIG. 2 can also serve to press the interior surfaces of the blank 8 against the vessel 90 so that the vessel is adhered thereto. The bag/blank combination article shown in FIG. 2 has a substantially flat tubular shape, with the vessel accommodated therein, that may be shipped to a location for distribution to a consumer, packaging facility, retailer, etc. The consumer can later form the article into a carton. The generally flat closed tubular configuration allows the article to be easily stored and transported.

[0055] FIG. 3 illustrates the bottom end of the partially erected blank 8, with the liquid-tight vessel 90 accommodated therein. In FIG. 3, the folded and glued blank 8 is opened into a generally tubular form. Opening the blank 8 as shown in FIG. 3 also expands or opens up the liquid-tight vessel 90 adhered to the interior surface of the blank 8. The bottom of the partially erected carton may be closed by folding the overlapping bottom flaps 24, 224 and 44, 244 over the open bottom end, and applying adhesive to the exterior sides of the bottom flaps 22, 44. The interior sides of the bottom flaps 234, 214 may then be adhered to the exterior sides of the bottom flaps 24, 44.

[0056] FIG. 4 illustrates the open top end of the partially erected carton. In general, the open top portion 94 of the liquid-tight vessel 90 opens when the blank 8 is opened to the tubular form. If desired, the vessel 90 may be pressed

against adhesive located on the interior sides of the partially erected carton at this time in order to further secure the vessel 90 to the interior of the carton. The vessel 90 may also be placed in the carton without using adhesive. In the illustrated embodiment, the liquid-tight vessel 90 is adhered at least to the upper minor blank 105 adjacent to the upper edge of the upper minor blank 105. Referring to FIG. 5, the vessel 90 within the partially erected carton is supported in an opened state so that the open end of the vessel can receive articles such as containers C (shown in FIG. 8).

[0057] Referring to FIGS. 5 and 6, after loading the partially erected carton with articles, the open top end of the partially erected carton may be closed. The top is closed by folding the top flaps 122, 142 inwardly at the oblique creases 126, 128 (FIG. 1C) and 146, 148, respectively. The top flaps 112, 132 are then folded inwardly about the fold line 152 (FIG. 1C) in the direction of the curved arrows as shown in FIG. 6. If desired, the top flaps 112, 132, 122, 142 may be adhered together.

[0058] The top end flaps 22, 42 of the major blank 5 are then folded over and the undersides of the top side flaps 12, 32 are adhered to the exterior sides of the top end flaps 22, 42 to complete erection of the carton. FIG. 7 illustrates the erected carton 280 with the articles accommodated therein. The carton 280 has a substantially parallelepipedal shape. In the exemplary embodiment shown in FIG. 7, the overlapped handle features 25, 125 and 45, 145 of the major blank 5 and the upper minor blank 105, respectively, form two-ply handles 247, 249, one at each end of the carton 280. The overlapping top flaps 112, 122, 132, 142, 12, 22, 32, 42 form a multi-ply top panel or closure 260, and the bottom flaps 214, 224, 234, 244, 14, 24, 34, 44 form a multi-ply bottom panel or closure 270. The tear strip 60 extends around the entire periphery of the carton 280.

[0059] FIG. 8 illustrates the carton 280 after opening and placed in an expanded configuration. The carton 280 may be opened, for example, by tearing the tear strip 60 around the periphery of the carton 280. When the tear strip 60 is removed, the top portion of the exterior ply (comprising portions of the major

blank 5) of the carton 280, including the upper portions of the panels 10, 20, 30, 40 located above the tear strip 60 and the top flaps 12, 22, 32, 42, can be lifted off of the top of the remaining bottom portion of the carton 280. The detached upper portion of the major blank 5 can be lifted off of the remainder of the carton 280 because the major blank 5 is not adhered to the upper minor blank 105 above the tear strip 60. As shown in FIG. 8, an upper portion 282 of the upper minor blank 105, comprising the top flaps 112, 122, 132, 142, can be placed in an expanded configuration by unfolding and pulling the flaps upwardly. Opening the flaps 112, 122, 132, 142 so that they extend upright creates an expanded interior volume 290 of the carton 280. The liquid-tight vessel 90 lines the interior volume 290 and renders it liquid-tight.

[0060] Still referring to FIG. 8, a first height H_1 of the carton 280 generally conforms to the height of the side panels 10, 30, which is approximately the height of the carton 280 when closed (FIG. 7). A second, expanded height H_2 indicates the height of the interior volume 290 of the carton 280 in its expanded configuration. Referring to FIG. 9, ice I, for example, can be poured over the containers C within the carton 280 when the carton is in its expanded configuration. The upper portion 282 of the upper minor blank 105 provides the additional capacity in the carton to receive the ice I. Because the liquid-tight vessel 90 can be adhered adjacent to the upper edge of the blank 105, the expanded volume 290 can be water-tight nearly to a top edge of the expanded carton 280. According to one embodiment of the present invention, the height of the interior volume 290 of the carton 280 increases by at least 10% when expanded from the closed configuration illustrated in FIG. 7, having height H_1 , to the open and expanded configuration shown in FIGS. 8 and 9, having height H_2 . According to another embodiment of the invention, the height H_2 is at least 20% greater than the first height H_1 .

[0061] The carton 280 can be carried using the reinforced, two-ply handles 247, 249 in the expanded configuration shown in FIGS. 8 and 9, as well as in the closed configuration shown in FIG. 7. If ice I is added to the interior volume

290, the added weight may constitute a significant weight to be borne by the carton 280. The two-ply sections of the carton 280 comprising the sections where the minor blanks 105, 205 overlap the major blank 5 add significant strength to the carton to enable relatively heavy loads to be carried in the carton 280. The reinforcement provided by the upper and lower minor blanks 105, 205 may be specifically targeted for regions of the carton 280 that require reinforcement, so that little board is wasted in forming the carton.

[0062] FIG. 10 illustrates the carton 280 with the top of the carton closed by a lid portion 295 of the major blank 5 that was removed from the carton 280 during opening of the carton. As shown in FIG. 10, the lid 295 can be used to close the top of the carton 280 when it is in its expanded configuration. In the illustrated embodiment, the carton 280 is loaded with fifteen twelve-ounce bottle beverage containers C disposed in a 3 x 5 x 1 configuration. Other arrangements are also possible.

[0063] FIG. 11A is a plan view of a multi-ply blank 308 used to form a carton 580 (illustrated in FIG. 14) according to the second embodiment of the invention. The blank 308 is formed from a major blank 305 and upper and lower minor blanks 405, 505, respectively, adhered, laminated or otherwise joined to the interior side of the major blank 305. In the drawing figures of this specification, the surface of the minor blanks 405, 505 are shaded with stippling solely to distinguish the minor blanks 405, 505 from the major blank 305, which is not stippled. The interior or underside surface of the major blank 305, with the minor blanks 405, 505 adhered thereto, is visible in FIG. 11A. In the illustrated embodiment, the minor blanks 405, 505 are adhered to the interior side of the major blank 5, although they may be adhered to the exterior or print side. Overlapping or coincident features in the blanks 305, 405, 505 are indicated by similar reference numbers, with reference numbers in the major blank 305 preceded by a "3," reference numbers in the upper minor blank 405 preceded by a "4," and reference numbers in the lower minor blank 505 preceded by a "5." FIG. 11B is a plan view of the exterior or print side of the major blank 305, FIG.

11C is a plan view of the upper minor blank **405** and **FIG. 11D** is a plan view of the lower minor blank **505**.

[0064] Referring to **FIG. 11B**, the major blank **305** comprises a first end panel **310**, a first side panel **320** foldably connected to the first end panel **310** at a transverse fold line **321**, a second end panel **330** foldably connected to the first end panel **320** at a transverse fold line **331**, and a second side panel **340** foldably connected to the second end panel **330** at a transverse fold line **341**. An adhesive flap **316** may be foldably connected to the first end panel **310** at a transverse fold line **318**.

[0065] Still referring to **FIG. 11B**, a first end top flap **312** of the major blank **305** is foldably connected to the first end panel **310** at a longitudinal fold line **352** and a first end bottom flap **314** is foldably connected to the first end panel **310** at a longitudinal fold line **354**. A first side top flap **322** is foldably connected to the first side panel **320** at the longitudinal fold line **352** and a first side bottom flap **324** is foldably connected to the first side panel **320** at the longitudinal fold line **354**. A second end top flap **332** is foldably connected to the second end panel **330** at the longitudinal fold line **352** and a second end bottom flap **334** is foldably connected to the second end panel **330** at the longitudinal fold line **354**. A second side top flap **342** is foldably connected to the second side panel **340** at a longitudinal cut-space hinge line **356** and a second side bottom flap **344** is foldably connected to the second side panel **340** at the longitudinal fold line **354**. The top flaps **312**, **322**, **332**, **342** extend along a first or upper marginal area of the blank major **305**. The bottom flaps **314**, **324**, **334**, **344** extend along a second or lower marginal area of the major blank **305**. A handle feature **315** is formed in the first end panel **310** and a similar handle feature **335** is formed in the second end panel **330**.

[0066] The bottom flaps **314**, **324**, **334**, **344** are arranged to form an interlocking bottom panel or closure in the erected carton **580** (**FIG. 14**). The bottom flap **324** includes a locking aperture **326**, and the bottom flap **344** includes a locking projection **346** dimensioned to be received within the locking

aperture **326**. The locking projection **346** and the locking aperture **326** can be larger than typical locking features in order to provide added load-bearing capacity for the carton **580**. The creasing of the locking projection **346** facilitates insertion of the locking projection **346** into the locking aperture **326**.

[0067] According to one aspect of the invention, a longitudinal tear strip **360** extends through the panels **310**, **320**, **330**. The tear strip **360** is defined at its upper and lower edges by spaced longitudinal tear lines **361**, **362**. The tear line **361** extends to an oblique cut **364** in the second end panel **330**, and to an oblique cut **365** in the first end panel **310**. A pull tab **366** may be included at one end of the tear strip **360** to facilitate access to the tear strip. The tear strip **360** allows a top of the carton **580** (FIG. 14) to be opened, as discussed in further detail below.

[0068] FIG. 11C illustrates the side of the upper minor blank **405** that is adhered to the major blank **305** illustrated in FIG. 11B. The opposite side of the upper minor blank **405** faces the interior of the carton **580** (illustrated in FIG. 14) formed from the multi-ply blank **308**. The upper minor blank **405** comprises a first end panel **410**, a first side panel **420** foldably connected to the first end panel **410** at a transverse fold line **421**, a second end panel **430** foldably connected to the first side panel **420** at a transverse fold line **431**, and a second side panel **440** foldably connected to the second end panel **430** at a transverse fold line **441**. A handle feature **415** is formed in the first end panel **410** and a similar handle feature **435** is formed in the second end panel **430**. An adhesive flap **416** may be foldably connected to the first end panel **410** at a transverse fold line **418**.

[0069] Referring to FIG. 11D, the lower minor blank **505** comprises a first end panel **510**, a first side panel **520** foldably connected to the first end panel **510** at a transverse fold line **521**, a second end panel **530** foldably connected to the first side panel **520** at a transverse fold line **531**, and a second side panel **540** foldably connected to the second end panel **530** at a transverse fold line **541**. An adhesive flap **516** may be foldably connected to the first end panel **510** at a transverse fold line **518**. A first end bottom flap **514** is foldably connected to the first end panel

510 at a longitudinal fold line **554**. A first side bottom flap **524**, which includes a locking aperture **526**, is foldably connected to the first side panel **520** at the longitudinal fold line **554**. A second end bottom flap **534** is foldably connected to the second end panel **530** at the longitudinal fold line **554**. A second side bottom flap **544**, which includes a locking projection **546**, is foldably connected to the second side panel **540** at the longitudinal fold line **554**. The bottom flaps **514, 524, 534, 544** extend along a lower marginal area of the lower minor blank **505**. The bottom flaps **514, 524, 534, 544** of the blank **505** overlap corresponding bottom flaps **314, 324, 334, 344**, respectively, in the major blank **305**.

[0070] Referring to **FIGS. 11A-11D**, the multi-ply blank **308** may be constructed by adhering the upper minor blank **405** and the lower minor blank **505** to the interior side of the major blank **305**. Each of the panels **410, 420, 430, 440** of the upper minor blank **405** may be adhered to corresponding panels **310, 320, 330, 340**, respectively, of the major blank **305**, below the longitudinal fold line **352** in the major blank **305**. The lower minor blank **505** can be adhered to the major blank **305** so that each panel or flap **510, 520, 530, 540, 514, 524, 534, 544** of the minor blank **505** is adhered to a corresponding panel or flap **310, 320, 330, 340, 314, 324, 334, 344**, respectively, of the major blank **305**. Glue strips, applied hot melt glue, lamination processes or other adhesives and means can be used to adhere the major and minor blanks **305, 405, 505** together.

[0071] Referring to **FIG. 11E**, a liquid-tight receptacle or vessel **390** is placed on the interior side of the multi-ply blank **308**. The liquid-tight vessel has sealed portions **392, 396** and an open top portion **394** through which articles can be placed in the vessel. The liquid-tight vessel **390** can be adhered to one or more locations of the panels **310, 410, 510, 320, 420, 520, 330, 430, 530, 340, 440, 540**. In one embodiment, it is sufficient to adhere the liquid-tight vessel **390** to the upper minor blank **405**, such as at an upper edge of the minor blank **405**. The liquid-tight vessel **390** may be joined to the multi-ply blank **308** so that when the blank **308** is opened to a generally tubular form, the upper open end of the liquid-

tight vessel 390 is supported in an open position by its adherence to the interior surface of the blank 308. The liquid-tight vessel 390 can be formed from, for example, any liquid-tight material.

[0072] An exemplary method of erection of the multi-ply blank 308 into the carton 580 and loading of the carton will now be discussed with reference to FIGS. 11A-14.

[0073] Referring to FIGS. 11A-11E and specifically to FIG. 12, the multi-ply blank 308 is folded about the transverse fold lines 321, 341 in the major blank 305 and about the corresponding transverse fold lines 421, 441, 521, 541 in the minor blanks 405, 505 so that the exterior side of the adhesive flap 316 of the major blank 305 is adhered to the interior sides of the second end panels 340, 440, 540 in the blanks 305, 405, 505, respectively. Folding of the blank 308 as shown in FIG. 12 can also serve to press the interior surfaces of the blank 308 against the vessel 390 so that the vessel is adhered thereto. The bag/blank combination article illustrated in FIG. 12 has a generally flat closed tubular form that may be shipped to a location for distribution to a consumer, packaging facility, retailer, etc.

[0074] FIG. 13 illustrates closure of the bottom end of the partially erected blank 308. In FIG. 13, the folded and glued blank 308 has been opened into a generally tubular form. Opening the blank 308 as shown in FIG. 13 also expands or opens up the liquid-tight vessel 390. The bottom of the partially erected carton may be closed by first folding the overlapping flaps 324, 524 over the open carton bottom. The overlapping flaps 324, 524 and 344, 544 are then folded over the bottom flaps 324, 524. The adhered overlapping locking projections 346, 546 of the blanks 305, 505, respectively, are then pressed in the direction of the arrow into the overlapping locking apertures 326, 526 in the bottom flaps 324, 524, respectively.

[0075] After closing the bottom of the partially erected carton, articles such as containers can be loaded into the partially erected carton. If desired, the liquid-tight vessel 390 may be pressed against the interior sides of the carton in order to

further secure the vessel 390 to adhesive located on the interior of the partially erected carton. In the illustrated embodiment, the liquid-tight vessel 390 is adhered at least to the upper minor blank 405 adjacent to the upper edge of the upper minor blank 405. After loading the partially erected carton with articles, the open top end of the partially erected carton may be closed. The top may be closed by folding the end top flaps 312, 332 inwardly about the fold line 352. The side top flaps 322, 342 are then folded inwardly about the lines 352, 356, respectively, and adhered to the top flaps 322, 342.

[0076] FIG. 14 illustrates the erected carton 580 with the articles accommodated therein. The carton 580 has a substantially parallelepipedal shape. In the exemplary embodiment shown in FIG. 14, the overlapped handle features 315, 415 and 335, 435 of the major blank 305 and the upper minor blank 405, respectively, form two-ply handles 457, 459, respectively, one at each end of the carton 580. The top flaps 312, 322, 332, 342 form a multi-ply top panel or closure 460. The interlocked, overlapping flaps 314, 514, 324, 524, 334, 534, 344, 544 form a multi-ply bottom panel or closure 470. The tear strip 360 extends around the entire periphery of the carton 580.

[0077] FIG. 15 illustrates the carton 580 after opening. The carton 580 is opened by pulling the tear strip 360 around a portion of the perimeter of the carton 580. The containers C accommodated within an interior volume 590 of the carton 580 can now be removed from the carton. After removing the tear strip 360, the top portion of the carton 580 defines a pivotable lid 595 that is pivotable about the hinge line 356 (FIG. 11B) in the direction of the curved arrow. With the lid 595 pivoted open, ice (not illustrated), for example, can be poured over the containers C accommodated within the interior volume 590 to cool the containers C. The liquid-tight vessel 390 within the carton 580 lines the interior volume 590 and serves to retain runoff from the ice as it melts. The lid 595 can be, for example, selectively opened and closed to close off the interior volume 590 of the carton 580. Alternatively, the lid 595 can be removed from the carton 580 by further tearing along the cut-space hinge line 356. In the

illustrated embodiment, the carton 580 is loaded with twelve twelve-ounce bottle beverage containers C disposed in a 3 x 4 x 1 configuration. Other arrangements are also possible.

[0078] The carton 580 can be carried using the reinforced, two-ply handles 457, 459 (FIG. 14) while in the opened configuration shown in FIG. 15, as well as in the closed configuration shown in FIG. 14. If ice is added to the interior volume 590, the added weight may constitute a significant weight to be borne by the carton 580. The two-ply sections of the carton 580 comprising the sections where the minor blanks 405, 505 overlap the major blank 305 adds significant strength to the carton to enable relatively heavy loads to be carried in the carton 580. The reinforcement provided by the upper and lower minor blanks 405, 505 may be specifically targeted for regions of the carton 580 that require reinforcement, so that little board is wasted in forming the carton.

[0079] FIG. 16A is a plan view of a major blank 705, and FIG. 16B is a plan view of a minor blank 805 according to a third embodiment of the invention. The minor blank 805 is adhered, laminated or otherwise joined to the interior side of the major blank 705 to form the multi-ply blank 708 illustrated in FIG. 16C. The multi-ply blank 708 is used to form a carton 880 (FIG. 17) according to the third embodiment of the invention. The exterior or print surface of the major blank 705 is visible in FIG. 16A. Overlapping or coincident features in the blanks 705, 805 are indicated by similar reference numbers, with reference numbers in the major blank 705 preceded by a "7," and reference numbers in the minor blank 805 preceded by an "8." In the drawing figures of this specification, the surface of the minor blank 805 is shaded with stippling solely to distinguish the minor blank 805 from the major blank 705, which is not stippled.

[0080] Referring to FIG. 16A, the major blank 705 comprises a first end panel 710, a first side panel 720 foldably connected to the first end panel 710 at a transverse fold line 721, a second end panel 730 foldably connected to the first end panel 720 at a transverse fold line 731, and a second side panel 740 foldably connected to the second end panel 730 at a transverse fold line 741. An adhesive

panel 716 may be foldably connected to the first end panel 710 at a transverse fold line 718. A first end top flap 712 is foldably connected to the first end panel 710 at a longitudinal fold line 752 and a first end bottom flap 714 is foldably connected to the first end panel 710 at a longitudinal fold line 754. A first side top flap 722 is foldably connected to the first side panel 720 at the longitudinal fold line 752 and a first side bottom flap 724 is foldably connected to the first side panel 720 at the longitudinal fold line 754. A second end top flap 732 is foldably connected to the second end panel 730 at the longitudinal fold line 752 and a second end bottom flap 734 is foldably connected to the second end panel 730 at the longitudinal fold line 754. A second side top flap 742 is foldably connected to the second side panel 740 at the longitudinal fold line 752 and a second side bottom flap 744 is foldably connected to the second side panel 740 at the longitudinal fold line 754. The top flaps 712, 722, 732, 742 extend along a first or upper marginal area of the major blank 705. The bottom flaps 714, 724, 734, 744 extend along a second or lower marginal area of the major blank 705. A handle feature 715 is formed in the first end panel 710 and a similar handle feature 735 is formed in the second end panel 730.

[0081] According to one aspect of the invention, a longitudinal tear strip 760 extends through the panels 710, 720, 730. The tear strip 760 is defined at its upper and lower edges by a pair of spaced longitudinal tear lines 761, 762. A pull tab 764 may be included at one end of the tear strip 760 to facilitate access to the tear strip. A cut-crease hinge line 756 extends from the opposite end of the tear strip 760, through the second side panel 740. The tear strip 760 allows a top of the carton 880 (FIG. 17) to be opened, as discussed in further detail below.

[0082] FIG. 16B illustrates the minor blank 805. Referring also to FIG. 16A, the minor blank 805 is dimensioned to overlap a central portion of the major blank 705 between the fold lines 752, 754. Referring to FIG. 16B, the minor blank 805 comprises a first end panel 810, a first side panel 820 foldably connected to the first end panel 810 at a transverse fold line 821, a second end panel 830 foldably connected to the first side panel 820 at a transverse fold line

831, and a second side panel **840** foldably connected to the second end panel **830** at a transverse fold line **841**. An adhesive panel **816** may be foldably connected to the first end panel **810** at a transverse fold line **818**. A handle feature **815** is formed in the first end panel **810** and a similar handle feature **835** is formed in the second end panel **830**.

[0083] Still referring to **FIG. 16B**, a longitudinal tear strip **860** extends through the panels **810**, **820**, **830**. The tear strip **860** is defined at its upper and lower edges by a pair of spaced longitudinal tear lines **861**, **862**. A pull tab **864** may be included at one end of the tear strip **860** to facilitate access to the tear strip. A cut-crease hinge line **856** extends away from the opposite end of the tear strip **860**, through the second side panel **840**.

[0084] Referring to **FIGS. 16A-16C**, in one exemplary embodiment, the multi-ply blank **708** may be constructed by adhering the minor blank **805** to the interior side of the major blank **705** below the tear strip **760** and below the hinge line **756**, and above the fold line **754**. In another embodiment, substantially all of each of the panels **810**, **820**, **830**, **840** of the minor blank **805** are adhered to corresponding panels **710**, **720**, **730**, **740**, between the longitudinal fold lines **752**, **754**. In this embodiment, the tear strips **760**, **860** are joined and operate as a single tear strip. In yet another embodiment, the panels **740**, **840** are adhered between the fold lines **752**, **754**, and the panels **810**, **820**, **830** are joined to corresponding panels **710**, **720**, **730** below the tear strips **760**, **860**. In this embodiment, the carton **880** (**FIG. 17**) is opened by opening the major blank **705** at the tear line **760** and subsequently opening the minor blank **805** at the tear line **860**. Glue strips, applied hot melt glue, lamination processes or other adhesives and means can be used to adhere the major and minor blanks **705**, **805** together.

[0085] Referring specifically to **FIG. 16C**, a liquid-tight receptacle or vessel **790** is then placed on the interior side of the multi-ply blank **708**. The liquid-tight vessel **790** has sealed portions **792**, **796** and an open top portion **794** through which articles can be placed in the vessel. The vessel **790** can be adhered to, for example, one or more locations of the panels **810**, **820**, **830**, **840**.

The blank 708 can be folded and glued into a closed, substantially flat tubular form as discussed above with reference to the first and second embodiments. The liquid-tight vessel 790 may be joined to the multi-ply blank 708 so that when the blank 708 is opened to a generally tubular form, the open top portion 794 of the liquid-tight vessel 790 is supported in an open position by its adherence to the interior surface of the blank 708.

[0086] The blank 708 can be opened up into a tubular form and the bottom closed by adhering the bottom flaps 714, 724, 734, 744 together. After closing the bottom of the partially erected carton, articles such as, for example, containers (not illustrated) can be loaded into the partially erected carton. The illustrated embodiment is dimensioned to accommodate twelve containers in a 3 x 4 x 1 configuration, although other arrangements are possible. Referring to FIG. 17, the top is closed by folding the end top flaps 712, 732 inwardly about the fold line 752. The side top flaps 722, 742 are then folded inwardly about the line 752, 756, respectively, and adhered to the flaps 722, 742. Closing the top completes erection of the carton 880. The carton 880 can be opened by removing the tear strips 760, 860, either simultaneously or individually, and pivoting the top of the carton open at the overlapping hinge lines 756, 856. The liquid-tight vessel 790 lines the interior volume of the carton 780.

[0087] In the above embodiments, the cartons are described as accommodating twelve or fifteen 12-ounce cans containers C in differing configurations. Other arrangements of containers, packages, articles, and other items, however, can be accommodated within a carton constructed according to the principles of the present invention. For example, a carton constructed according to the principles of the present invention would also work satisfactorily if the carton were sized and shaped to hold articles in other configurations, such as 4 x 3 x 1, 3 x 6 x 1, 2 x 4 x 1, 2 x 5 x 1, 2 x 6 x 1, 4 x 6 x 1, etc., and multi-tier variations of the aforementioned configurations. The dimensions of the blanks may also be altered, for example, to accommodate various container forms. For example, 16-

ounce petaloid bottles may be accommodated within cartons constructed according to the principles of the present invention.

[0088] In the illustrated embodiments, the liquid-tight vessels have sealed lower and side portions before being secured to the blanks. In an alternative embodiment, the vessels may be formed from barrier films and sealed during erection of the carton, such as is disclosed in U.S. Patent Application Publication No. 2007/0137222 A1.

[0089] In the exemplary embodiments discussed above, the major and minor blanks may be formed from, for example, clay coated newsprint (CCN), solid unbleached sulfate board (SUS), paperboard, and other materials. In general, the blanks may be constructed from paperboard having a caliper of at least about 14, for example, so that it is heavier and more rigid than ordinary paper. The blanks can also be constructed of other materials, such as cardboard, or any other material having properties suitable for enabling the carton to function at least generally as described above. The blanks can be coated with, for example, a clay coating. The clay coating may then be printed over with product, advertising, and other information or images. The blanks may then be coated with a varnish to protect information printed on the blanks.

[0090] The blanks may also be coated with, for example, a moisture barrier layer, on either or both sides of the blanks. For example, interior surfaces of the blanks may be coated with a moisture barrier layer to protect the blanks from condensation that may form on adjacent surfaces of the liquid-tight vessels. The blanks can also be laminated to or coated with one or more sheet-like materials at selected panels or panel sections.

[0091] The above embodiments may be described as having one or more panels adhered together by glue. The term "glue" is intended to encompass all manner of adhesives commonly used to secure carton panels and/or flaps in place.

[0092] The term "line" as used herein includes not only straight lines, but also other types of lines such as, for example, curved, curvilinear or angularly displaced and/or interrupted lines.

[0093] In accordance with the exemplary embodiment of the present invention, a fold line can be any substantially linear, although not necessarily straight, form of disruption or weakening in the blanks that facilitates folding therealong. More specifically, but not for the purpose of narrowing the scope of the present invention, examples of fold lines include: score lines; crease lines; a cut or a series of cuts that extend partially into and/or completely through the material along a desired line of weakness; and various sequential and/or overlapping combinations of these exemplary features.

[0094] In the present specification, a “panel” or “flap” need not be flat or otherwise planar. A “panel” or “flap” can, for example, comprise a plurality of interconnected generally flat or planar sections.

[0095] For purposes of the description presented herein, the term “line of disruption” can be used to generally refer to, for example, a cut line, a score line, a crease line, a tear line, or a fold line (or various sequential and/or overlapping combinations thereof) formed in a blank. A “breachable” line of disruption is a line of disruption that is intended to be breached during ordinary use of the carton. An example of a breachable line of disruption is a tear line.

[0096] It will be understood by those skilled in the art that while the present invention has been discussed above with reference to exemplary embodiments, various additions, modifications and changes can be made thereto without departing from the spirit and scope of the invention as set forth in the following claims.

WHAT IS CLAIMED IS:

1. An enclosed carton having an interior surface, the carton being constructed from a major blank and at least one minor blank adhered to the major blank, and the at least one minor blank overlapping less than an entirety of the major blank, the major blank having top end flaps at a first marginal area and bottom end flaps at a second marginal area, the carton comprising:
 - a top closure formed by the top end flaps of the major blank at the first marginal area;
 - a bottom closure formed by the bottom end flaps of the major blank at the second marginal area;
 - a first side panel;
 - a second side panel;
 - a first end panel;
 - a second end panel, wherein the side and end panels, the top closure, and the bottom closure enclose and define in part an interior volume of the carton; and
 - a liquid-tight vessel attached to at least a portion of the interior surface and lining at least a portion of the interior volume of the carton;
 wherein the at least one minor blank comprises an upper minor blank adhered to the major blank adjacent to the top closure and a lower minor blank adhered to the major blank at the bottom closure, the upper minor blank has top end flaps that overlap the top end flaps of the major blank, and the lower minor blank has bottom end flaps that overlap the bottom end flaps of the major blank.
2. The carton of claim 1, wherein the vessel is adhered to the at least one minor blank.
3. The carton of claim 1, wherein the at least one minor blank is adhered to at least two of the first side panel, the second side panel, the first end panel, and the second end panel.
4. The carton of claim 1, wherein the at least one minor blank is adhered to the major blank between the bottom and top closures.
5. The carton according to any one of claims 1 to 4, wherein the vessel is adhered to the interior surface adjacent to the top closure.
6. The carton according to any one of claims 1 to 4, further comprising a tear strip, the tear strip at least partially defining a lid in the carton.

7. The carton of claim 6, wherein the tear strip extends around a periphery of the carton so that the lid is removable.
8. The carton of claim 6, wherein the tear strip extends around a part of the periphery of the carton so that the lid is pivotable.
9. The carton according to any one of claims 1 to 8, wherein the carton is substantially parallelepipedal.
10. The carton according to any one of claims 1 to 8, further comprising at least one handle comprising a first handle feature extending in the major blank and a second handle feature extending in the minor blank, the second handle feature being generally aligned with the first handle feature.
11. An enclosed multi-ply carton constructed from a major blank and at least one minor blank and having an interior surface, the major blank having top end flaps at a first marginal area and bottom end flaps at a second marginal area, the carton comprising:
 - a top closure formed by the top end flaps of the major blank at the first marginal area;
 - a bottom closure formed by the bottom end flaps of the major blank at the second marginal area;
 - a first side panel;
 - a second side panel;
 - a first end panel;
 - a second end panel, wherein the side and end panels, the top closure, and the bottom closure enclose and define in part an interior volume of the carton; and
 - a liquid-tight vessel attached to at least a portion of the interior surface and lining at least a portion of the interior volume of the carton, wherein
 - the at least one minor blank overlapping less than the entirety of the first side panel, the second side panel, the first end panel, and the second end panel, the at least one minor blank is adhered to at least two of the first side panel, the second side panel, the first end panel, and the second end panel, and the at least one minor blank comprises an upper minor blank adhered to the major blank adjacent to the top closure and a lower minor blank adhered to the major blank at the bottom closure, the upper minor blank has top end flaps that overlap the top end flaps of the major blank, and the lower minor blank has bottom end flaps that overlap the bottom end flaps of the major blank.

12. The carton of claim 11, wherein the at least one minor blank is adhered to the major blank between the bottom and top closures.
13. The carton according to any one of claim 11 or 12, wherein the vessel is adhered to the interior surface adjacent to the top closure.
14. The carton of claim 11, wherein the bottom flaps comprise:
a first side bottom flap; and
a second side bottom flap.
15. The carton according to any one of claims 11 to 14, further comprising a tear strip.
16. The carton according to any one of claims 11 to 15, wherein the carton is substantially parallelepipedal.
17. An article, comprising:
a multi-ply blank comprising at least a major blank and at least one minor blank adhered to the major blank, a first side panel, a second side panel, a first end panel, and a second end panel comprising sections of the major blank; the major blank including top end flaps at a first marginal area and bottom end flaps at a second marginal area; the minor blank is adhered to at least two of the first side panel, the second side panel, the first end panel, and the second end panel; the minor blank overlapping less than the entirety of the first side panel, the second side panel, the first end panel, or the second end panel;
a bottom closure formed by at least partially overlapping the bottom end flaps at the second marginal area;
a top closure formed by at least partially overlapping the top end flaps at the first marginal area;
a first side panel;
a second side panel;
a first end panel;
a second end panel; and
a liquid-tight vessel adhered to at least a portion of an interior surface of the blank, the first and second side panels, the first and second end panels, and the top closure, and the bottom closure enclose and define at least in part an interior of the article, the first side panel;

wherein the at least one minor blank an upper minor blank adhered to the major blank adjacent to the top closure and a lower minor blank adhered to the major blank at the bottom closure, the upper minor blank has top end flaps that overlap the top end flaps of the major blank, and the lower minor blank has bottom end flaps that overlap the bottom end flaps of the major blank.

18. The article of claim 17, wherein the article is folded substantially flat.
19. The article according to claim 17 or 18, wherein the article has a flat tubular form with the vessel located in an interior of the flat tubular form.
20. The article according to claim 17, 18 or 19, wherein one of the end panels is glued adjacent to one of the side panels.
21. The article according to claim 17, 18 or 19, wherein the side panels are substantially rectangular.
22. The article of claim 17, wherein at least one minor blank is adhered to the major blank between the at least one bottom flap and the at least one top flap.
23. A method of utilizing a multi-ply carton constructed from a major blank and at least one minor blank and having an interior surface, the major blank having top end flaps at a first marginal area and bottom end flaps at a second marginal area, the method comprising:
 providing a carton, comprising:
 a bottom closure formed by the bottom end flaps of the major blank at the second marginal area;
 a top closure formed by the top end flaps of the major blank at the first marginal area;
 a first side panel;
 a second side panel;
 a first end panel;
 a second end panel, wherein the side and end panels, the top closure, and the bottom closure enclose and define in part an interior volume of the carton; and
 a liquid-tight vessel attached to at least a portion of the interior surface and lining at least a portion of the interior volume of the carton;
 the at least one minor blank is adhered to at least two of the first side panel, the second side panel, the first end panel, and the second end panel; the

minor blank overlapping less than the entirety of the first side panel, the second side panel, the first end panel, or the second end panel, and the at least one minor blank comprises an upper minor blank adhered to the major blank adjacent to the top closure and a lower minor blank adhered to the major blank at the bottom closure, the upper minor blank has top end flaps that overlap the top end flaps of the major blank, and the lower minor blank has bottom end flaps that overlap the bottom end flaps of the major blank;

closing the top closure of the carton by inwardly folding the top end flaps that are overlapped by a respective top end flap of the upper minor blank;

opening the top closure of the carton; and

expanding the interior volume of the carton by at least partially unfolding the at least one minor blank to define an upper portion of the at least one minor blank.

24. The method of claim 23, wherein opening a top portion of the carton comprises tearing at least one tear feature in the carton.

25. The method according to claim 23 or 24, wherein the carton is substantially parallelepipedal.

26. The carton of claim 1, wherein each of the top end flaps of the upper minor blank and bottom end flaps of the lower minor blank overlap substantially the entirety of a respective top or bottom end flap

27. The carton of claim 1, wherein each of the top end flaps of the upper minor blank overlap substantially the entirety of a respective top end flap of the major blank.

28. The carton of claim 27, wherein each of the bottom end flaps of the lower minor blank overlap substantially the entirety of a respective bottom end flap of the major blank.

29. The article of claim 17, wherein each of the top end flaps of the upper minor blank and bottom end flaps of the lower minor blank overlap substantially the entirety of a respective top or bottom end flap

30. The article of claim 17, wherein each of the top end flaps of the upper minor blank overlap substantially the entirety of a respective top end flap of the major blank.

31. The article of claim 30, wherein each of the bottom end flaps of the lower minor blank overlap substantially the entirety of a respective bottom end flap of the major blank.

32. The method of claim 23, wherein each of the top end flaps of the upper minor blank and bottom end flaps of the lower minor blank overlap substantially the entirety of a respective top or bottom end flap.

33. The method of claim 23, further comprising closing the bottom closure of the carton by inwardly folding the bottom end flaps of the major blank that are overlapped by a respective bottom end flap of the minor blank.

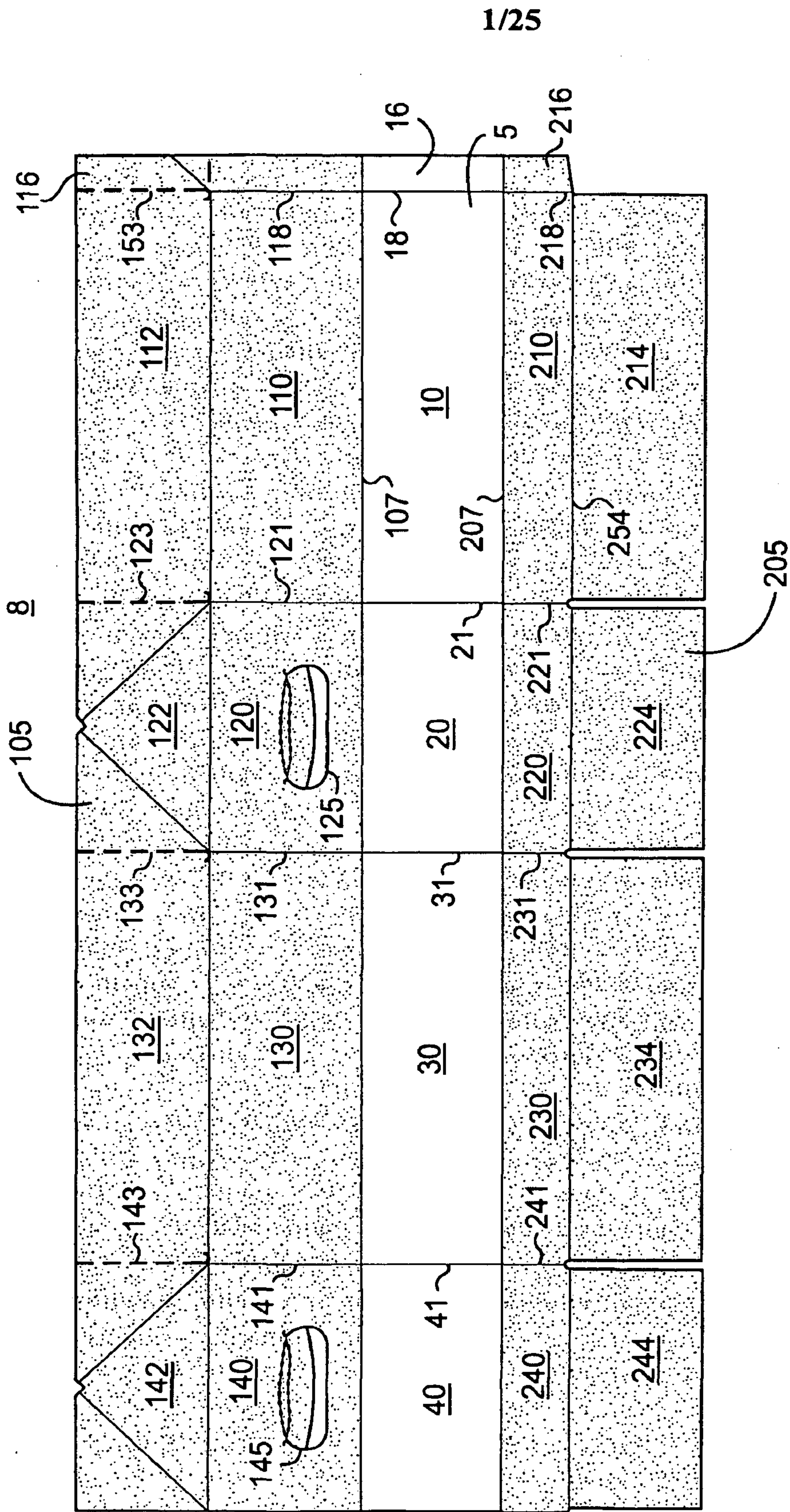

FIG. 1A

5

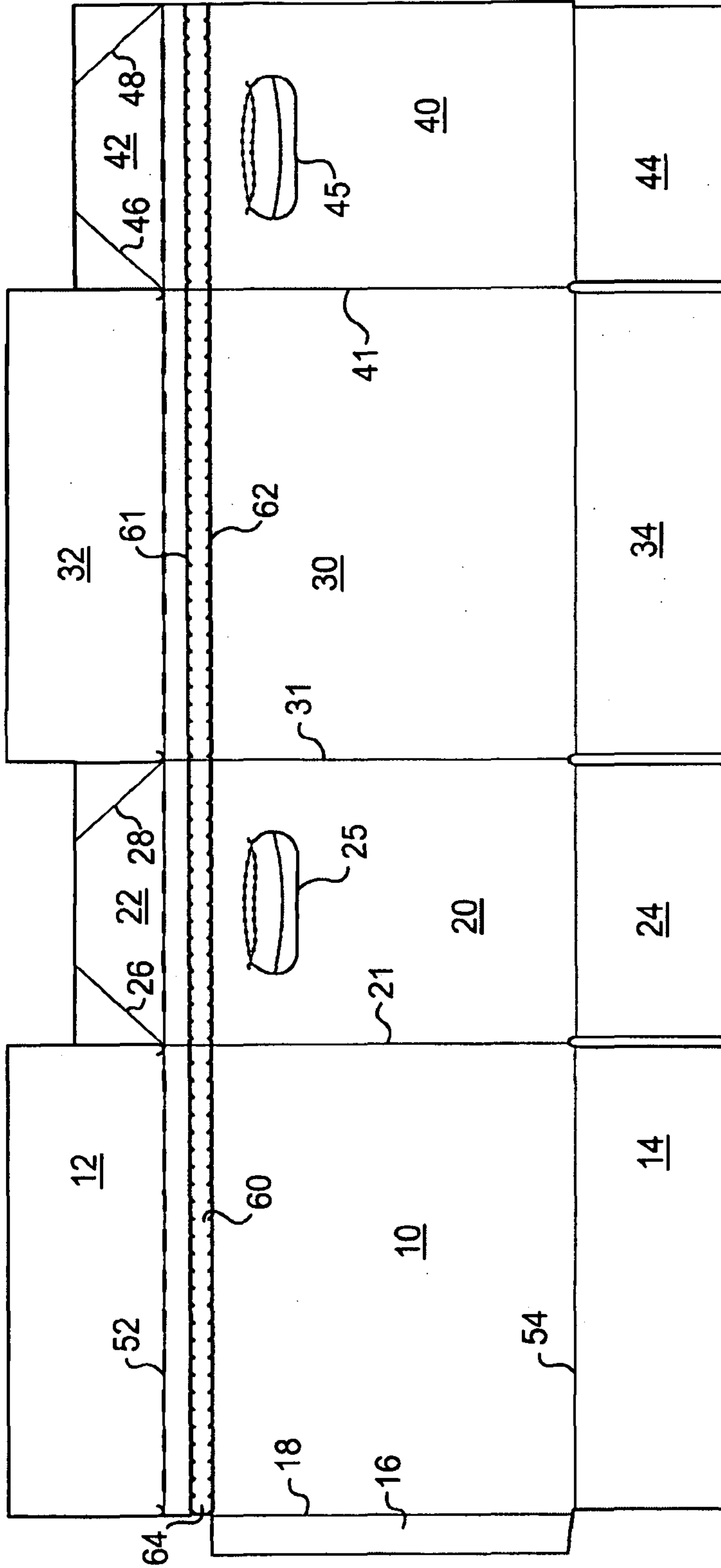

FIG. 1B

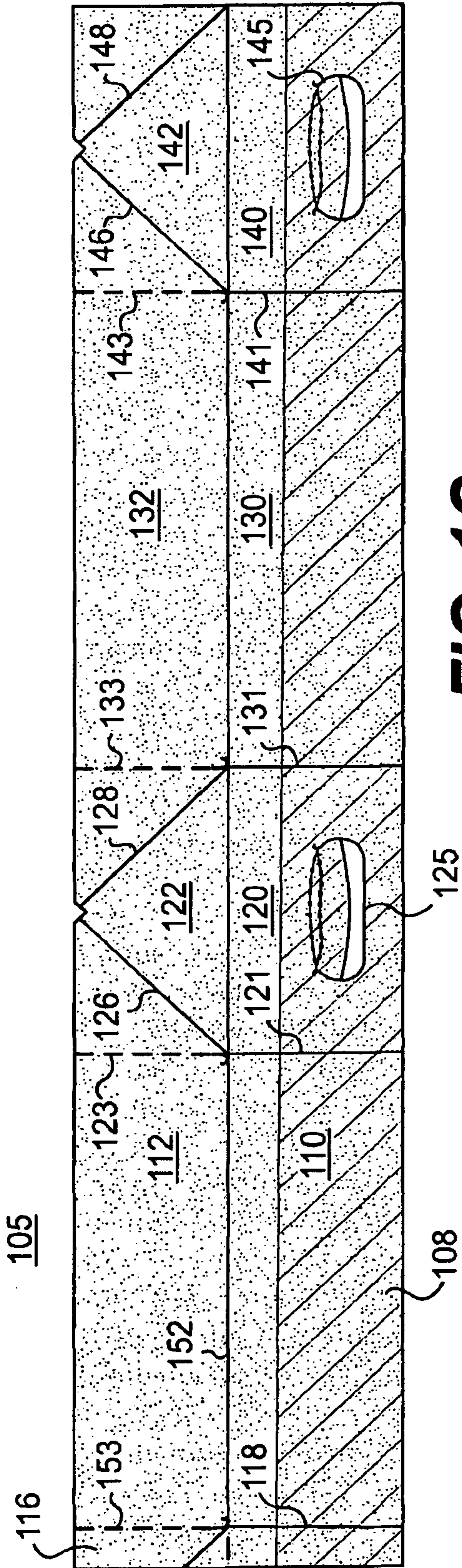

FIG. 1C

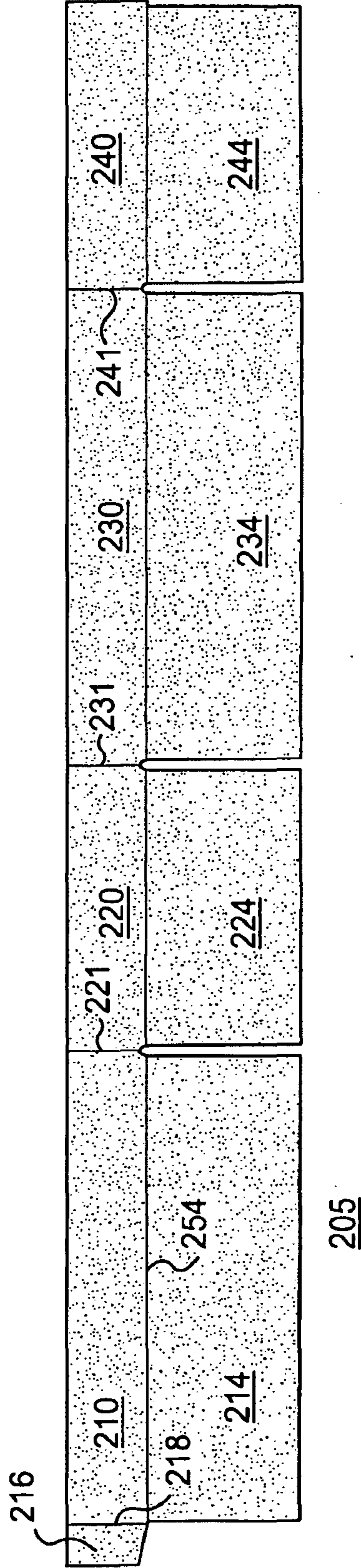

FIG. 1D

4/25

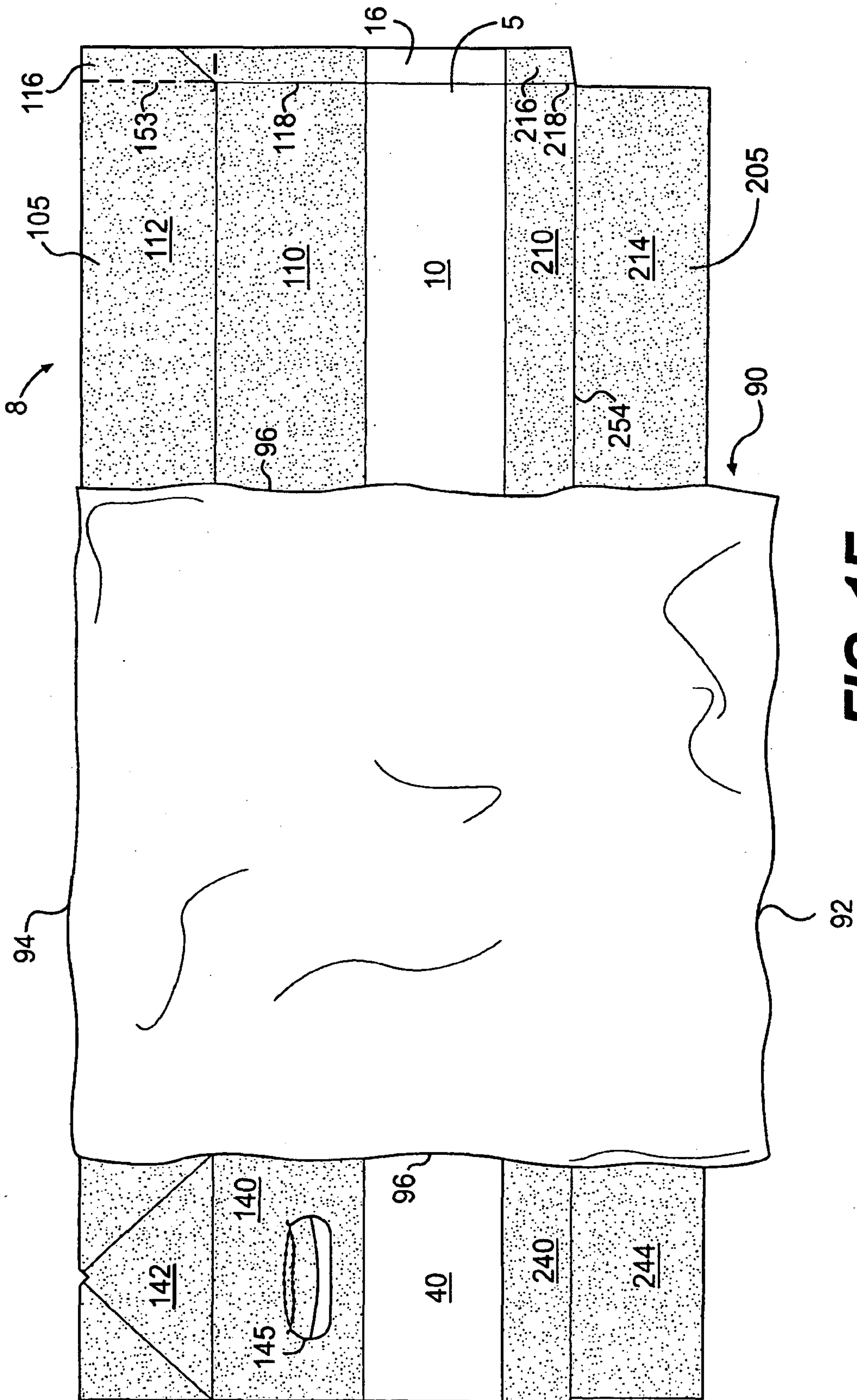

FIG. 1E

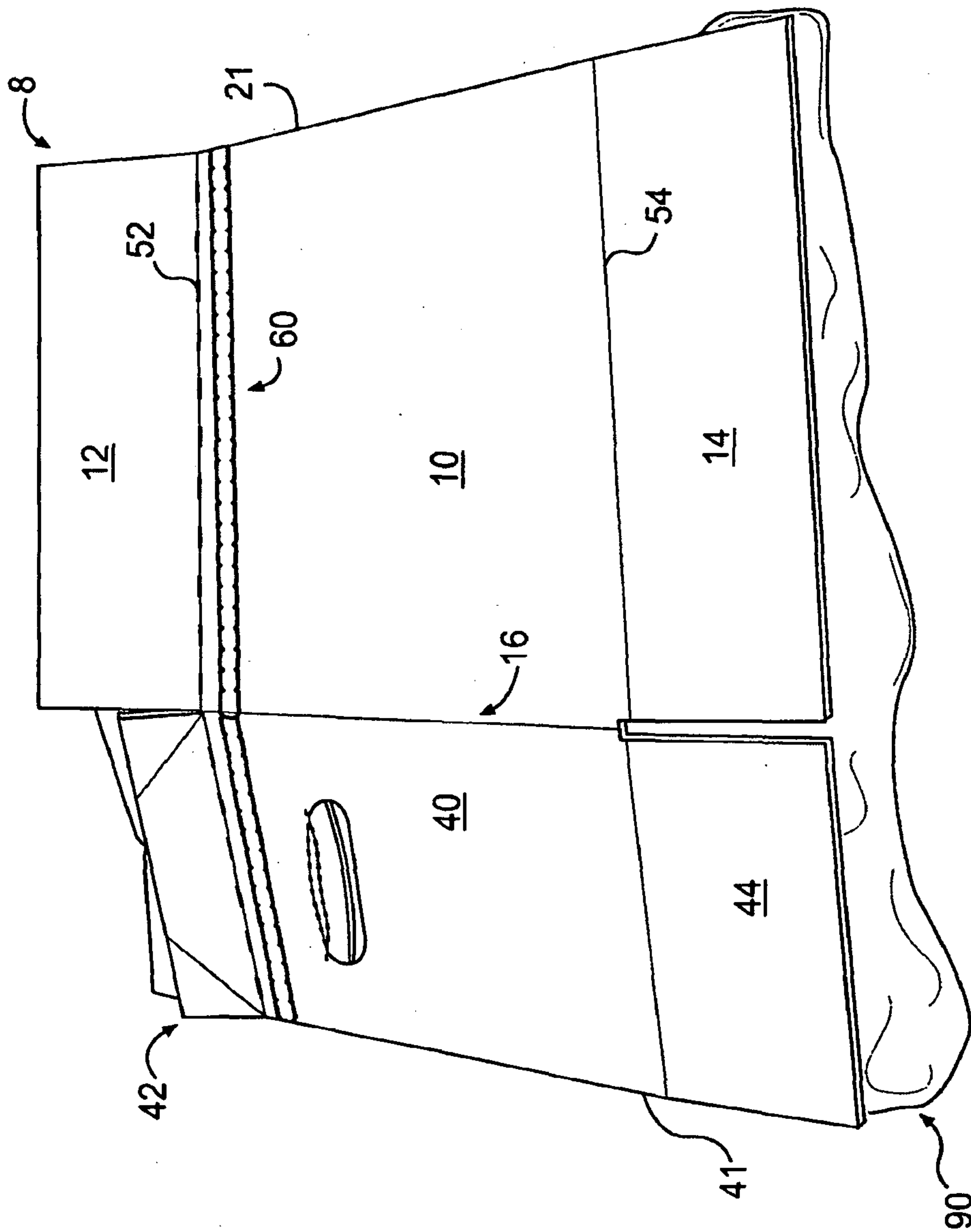

FIG. 2

6/25

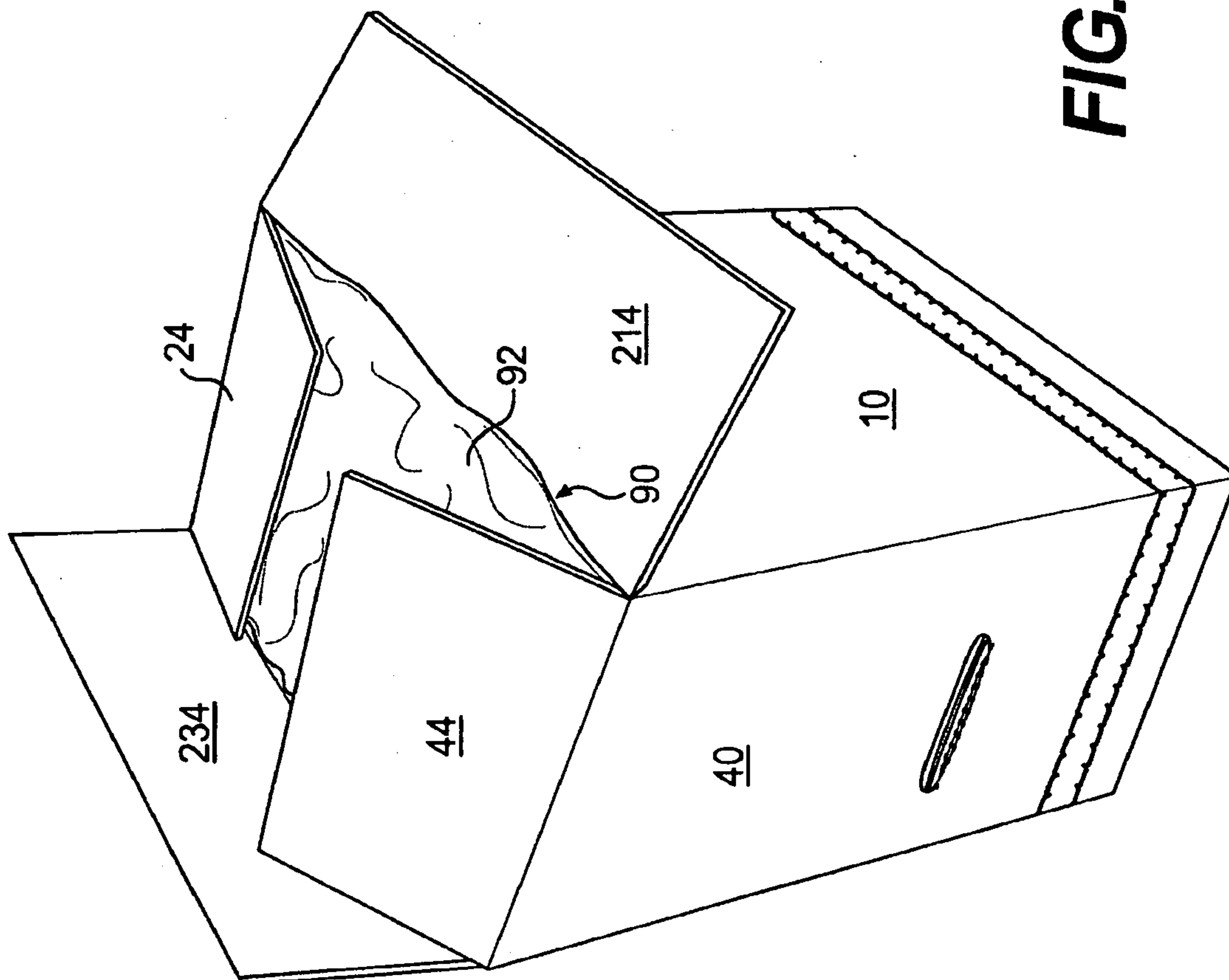

FIG. 3

7/25

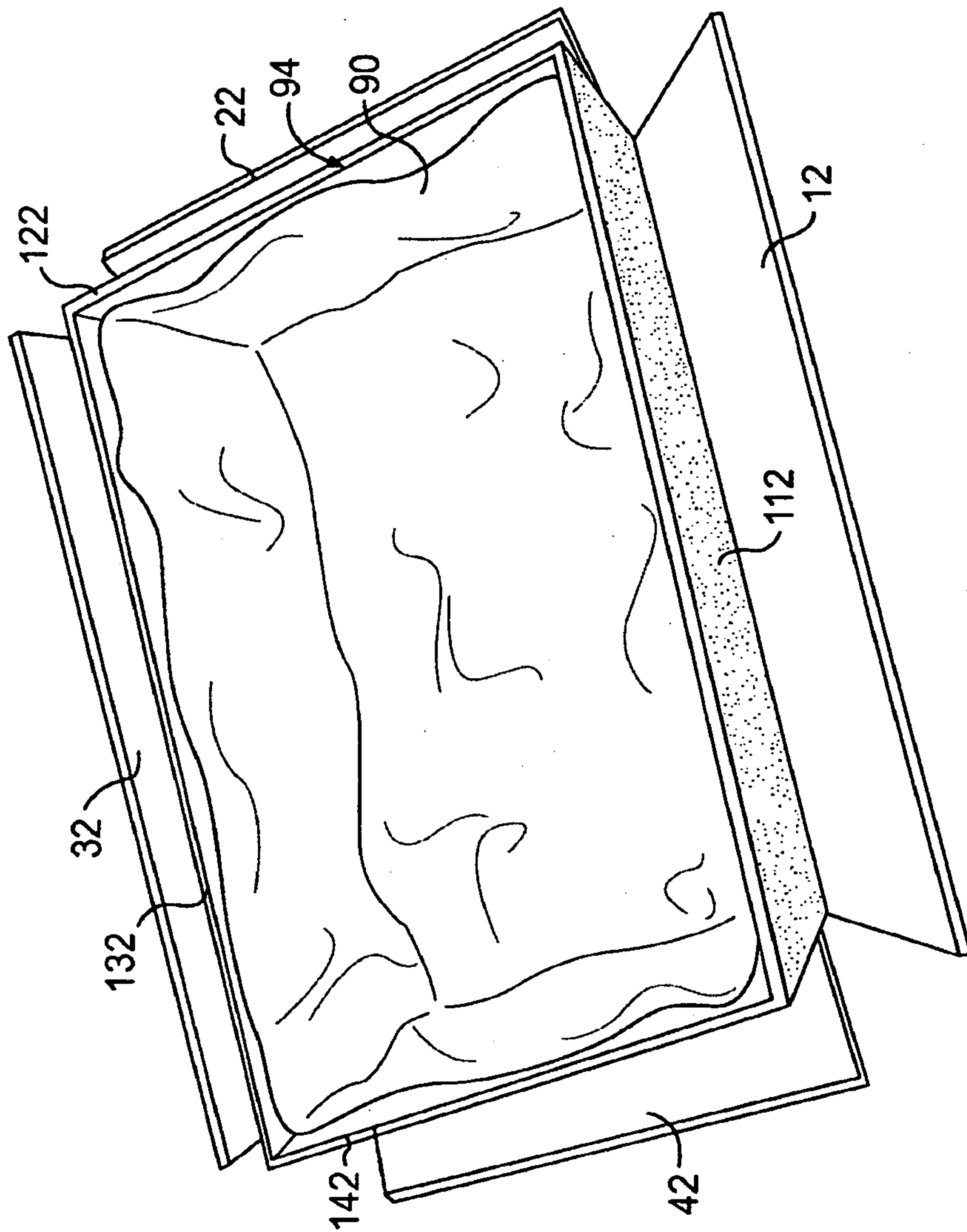

FIG. 4

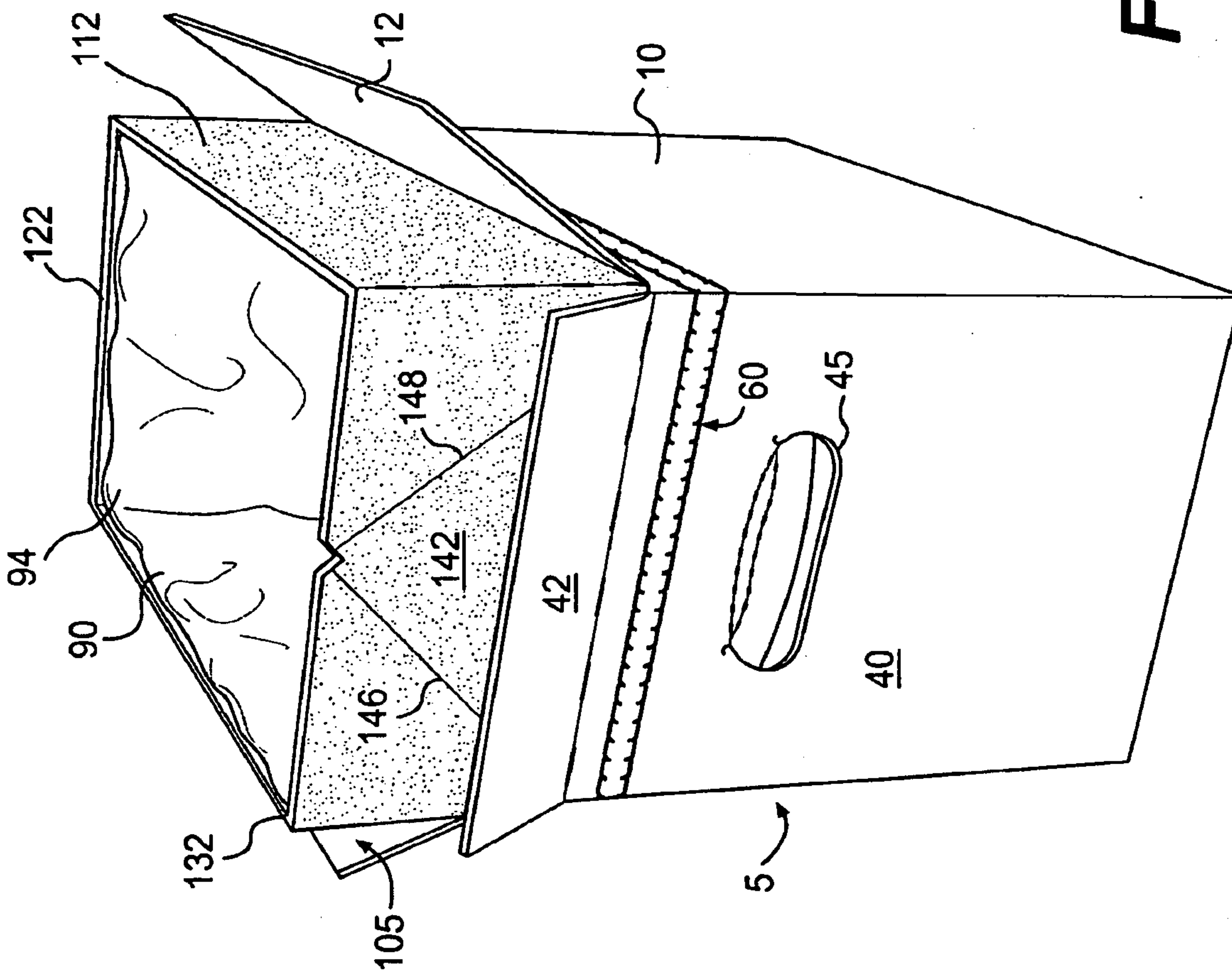

FIG. 5

9/25

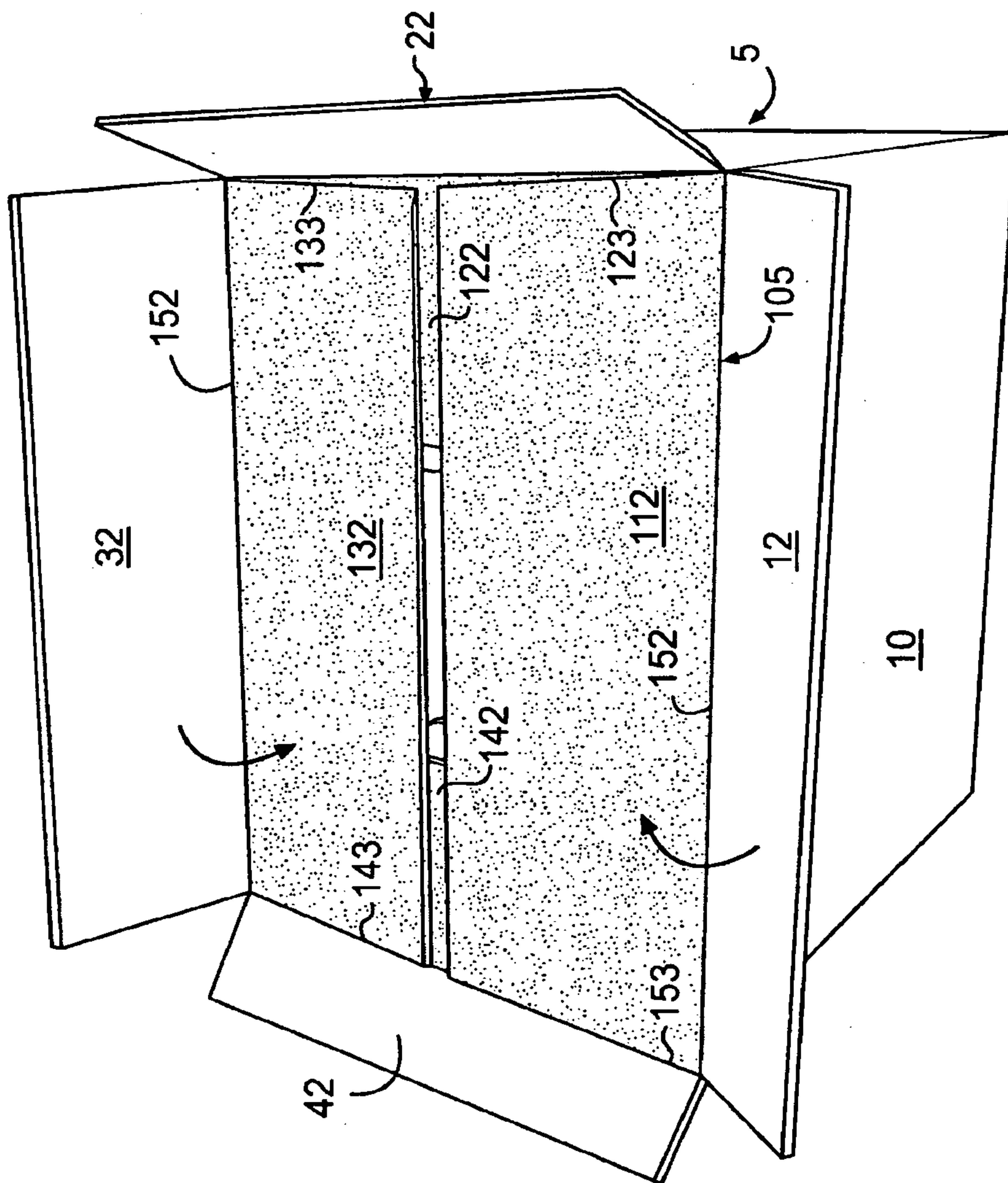

FIG. 6

10/25

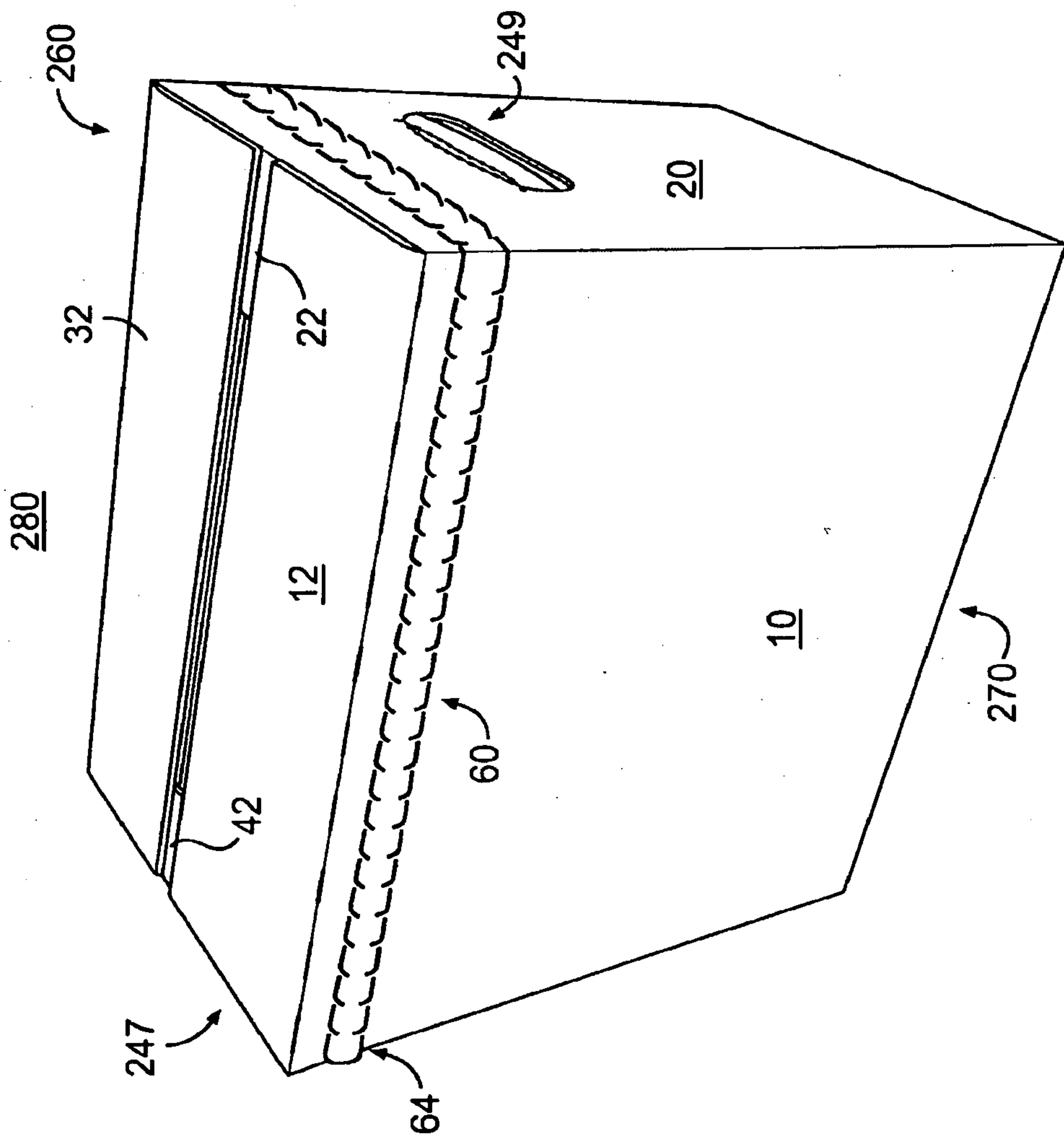

FIG. 7

11/25

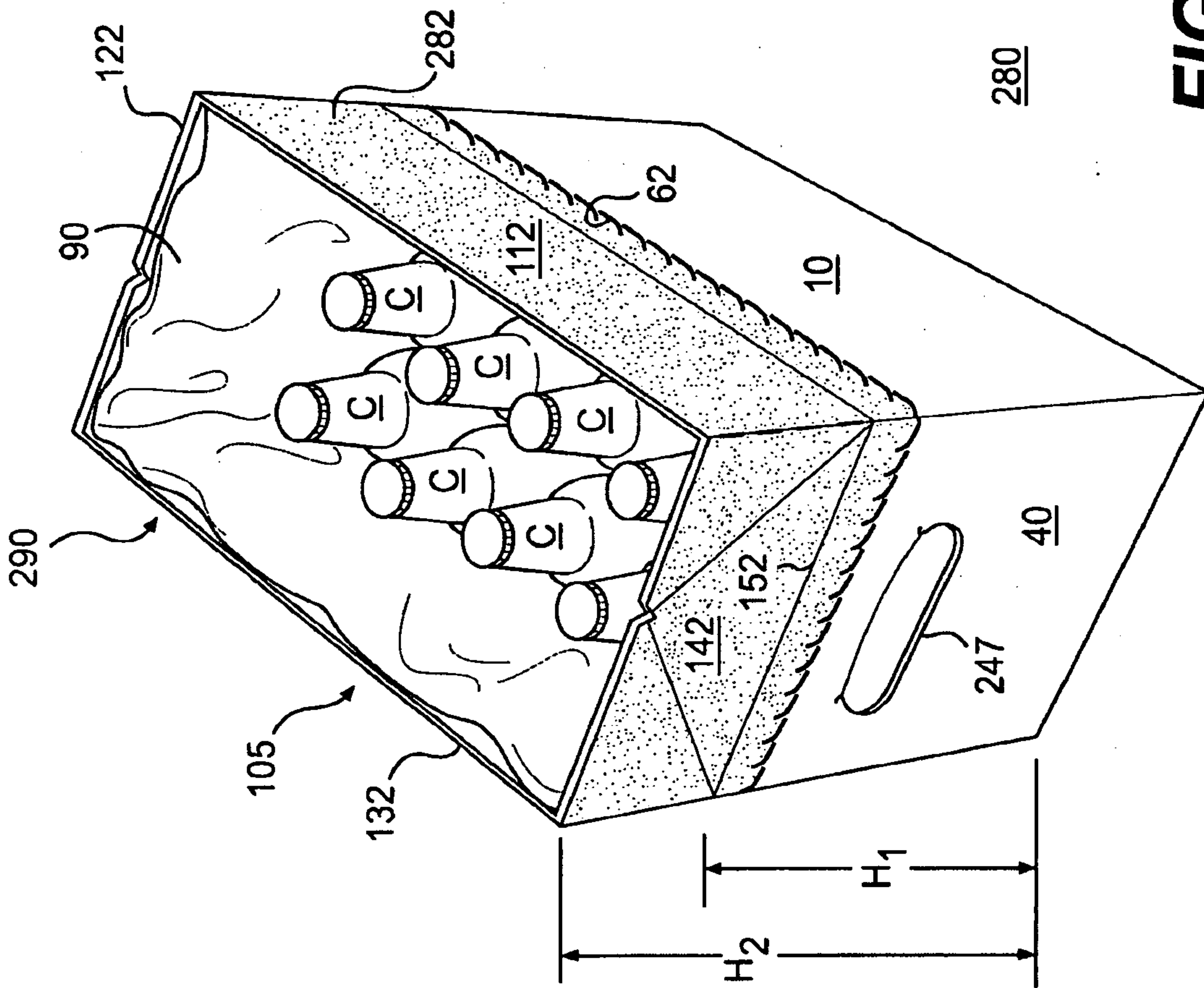

FIG. 8

12/25

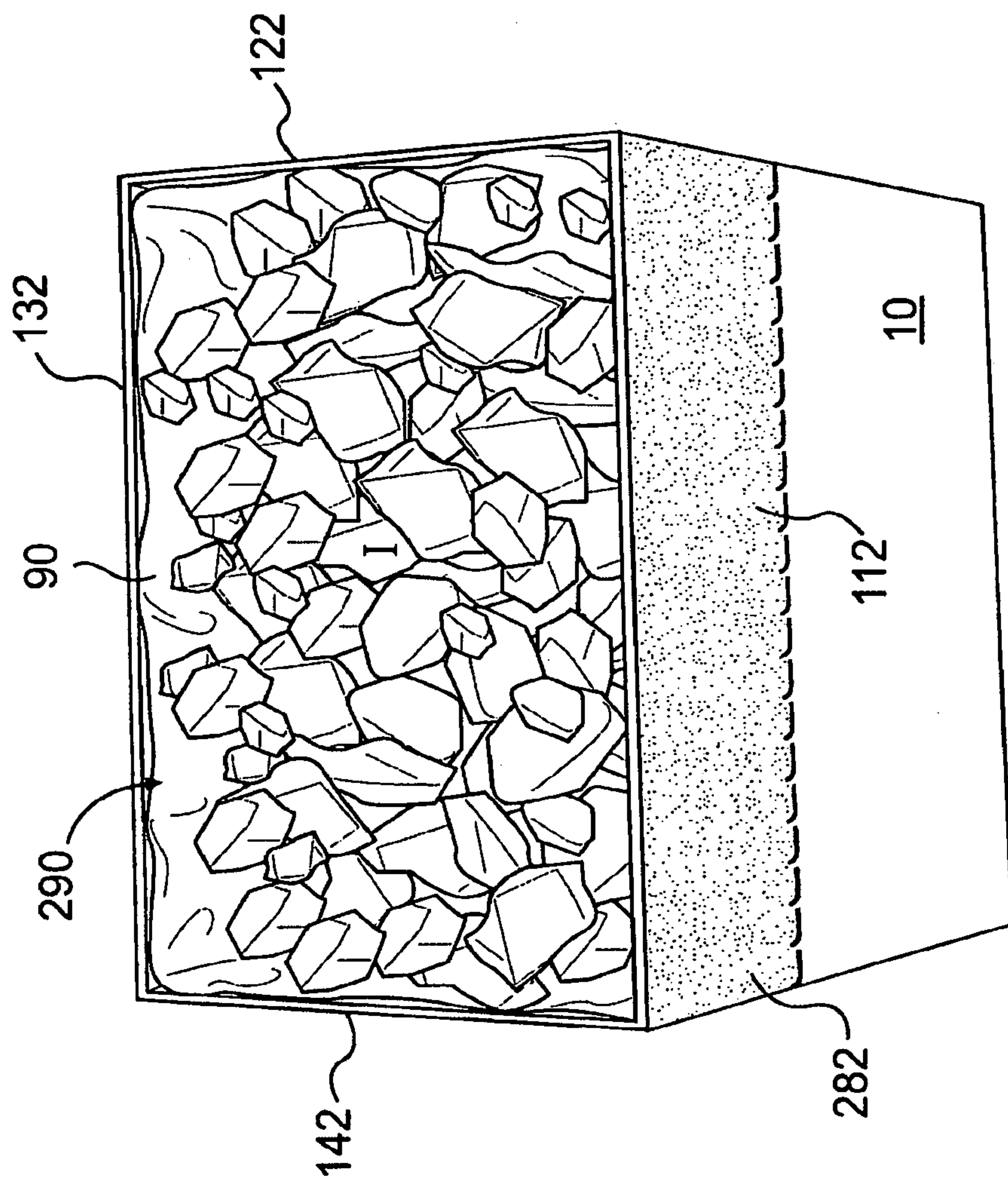

FIG. 9

280

13/25

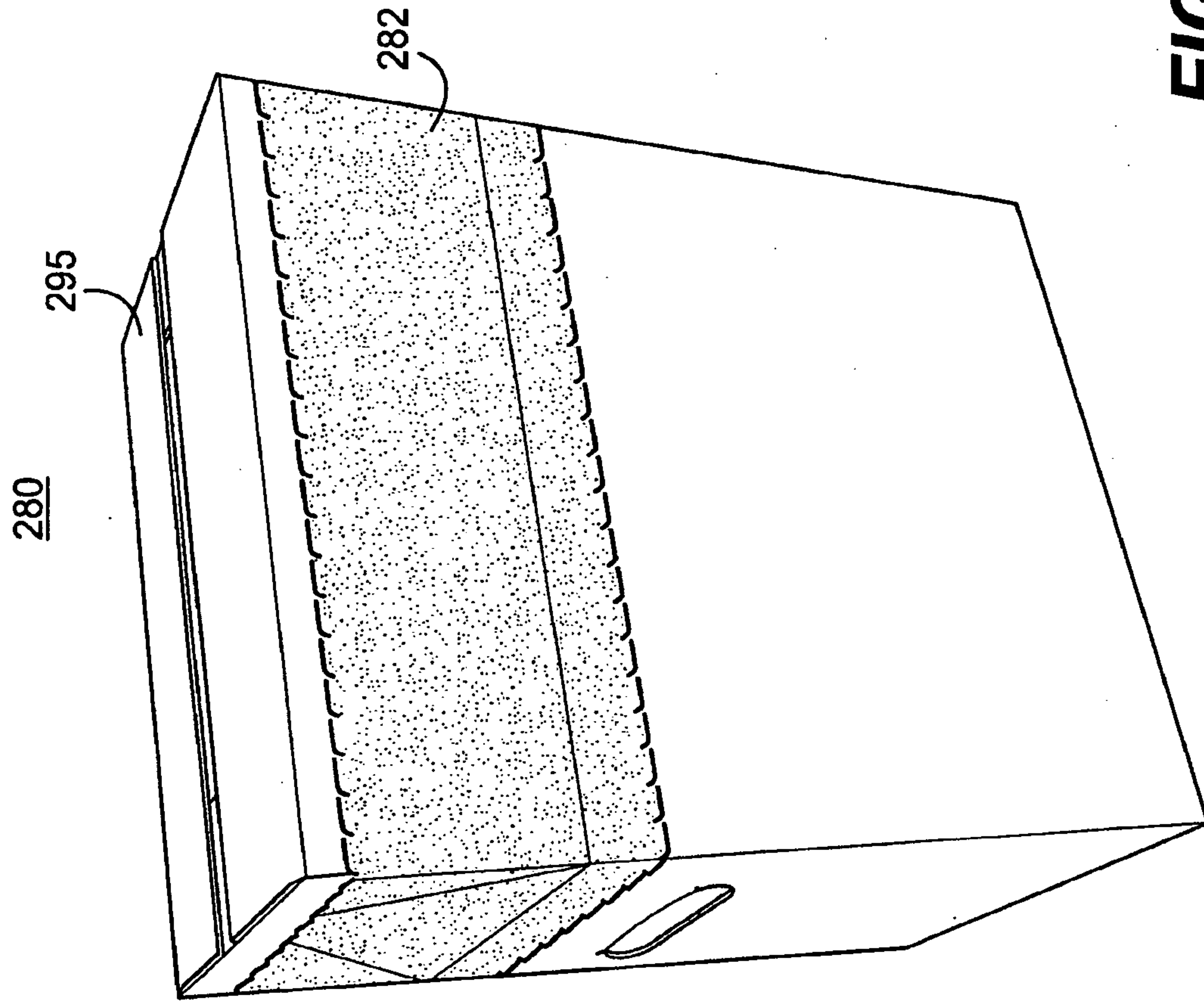

FIG. 10

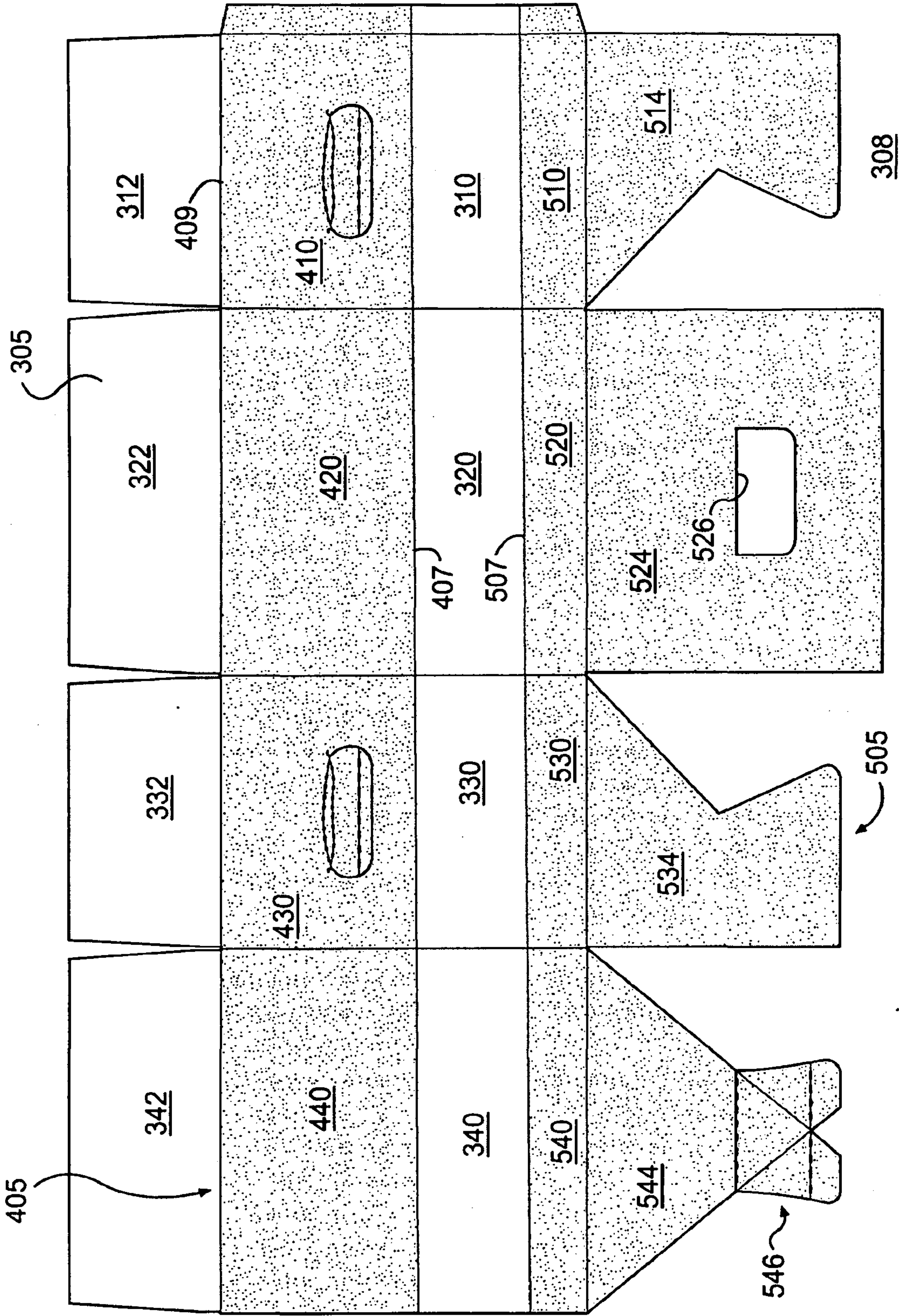

FIG. 11A

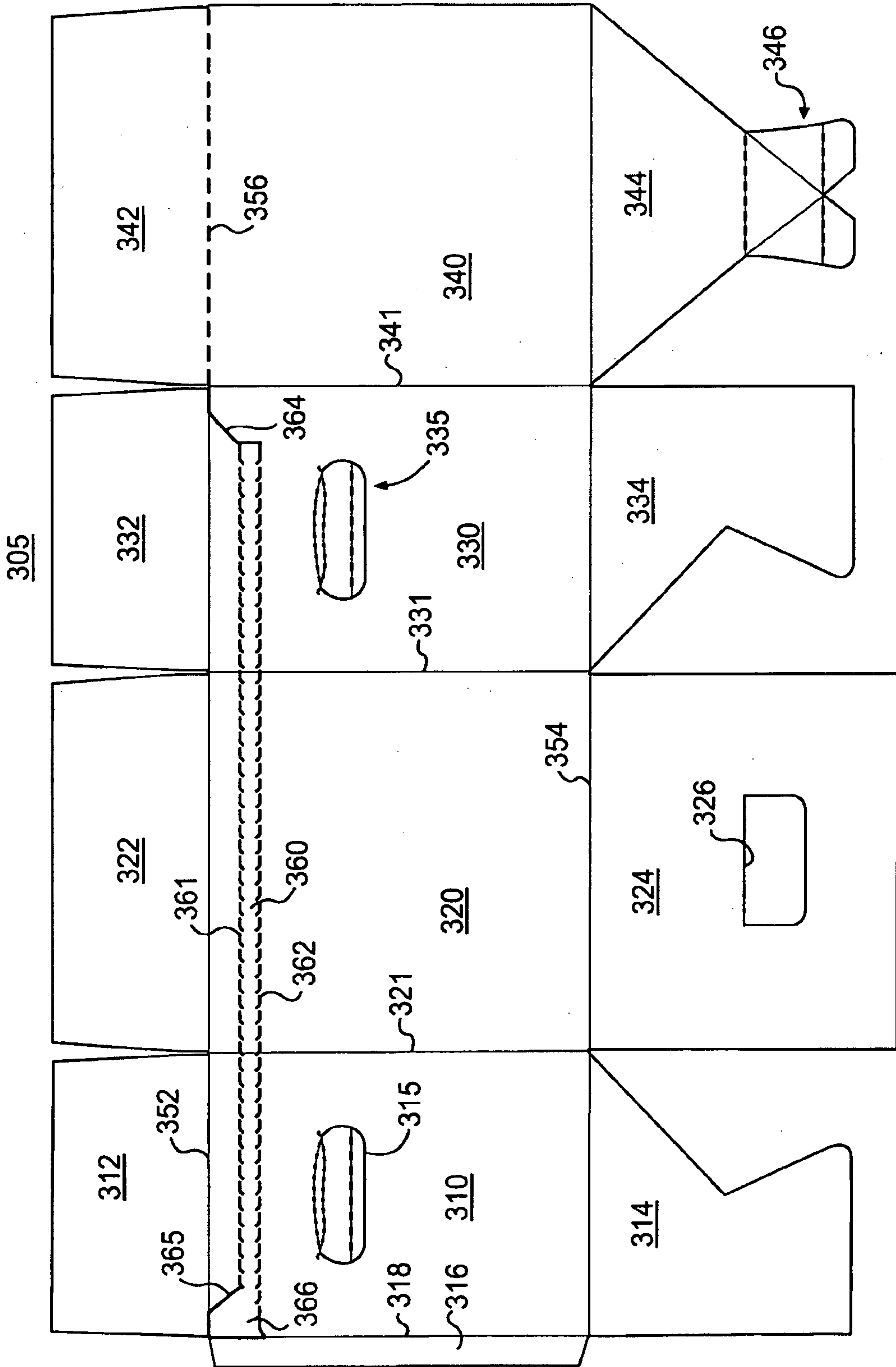

FIG. 11B

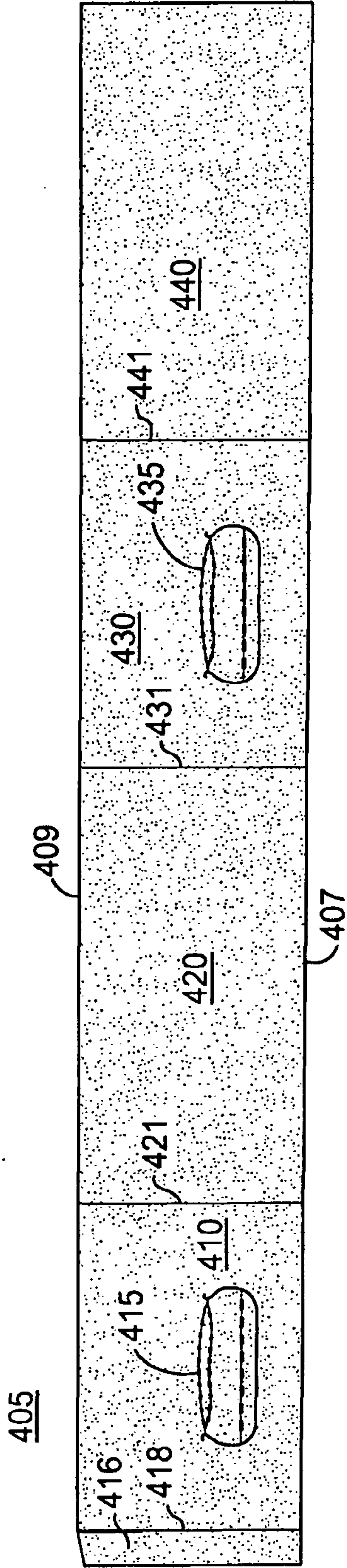
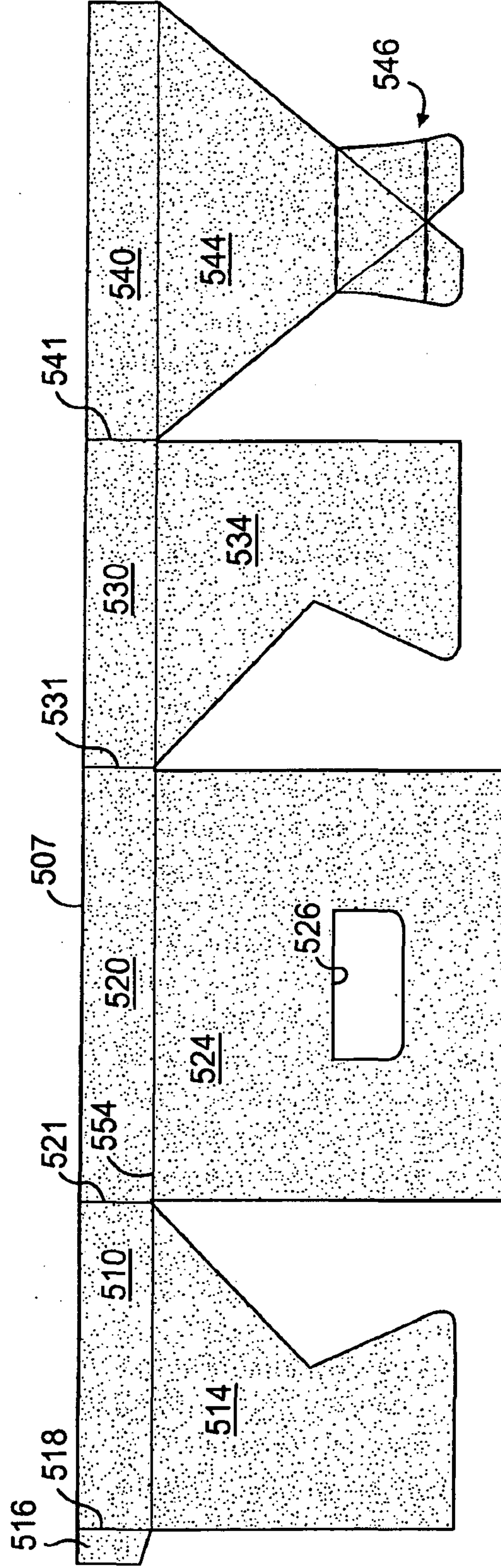

FIG. 11C



505

FIG. 11D

546

526

17/25

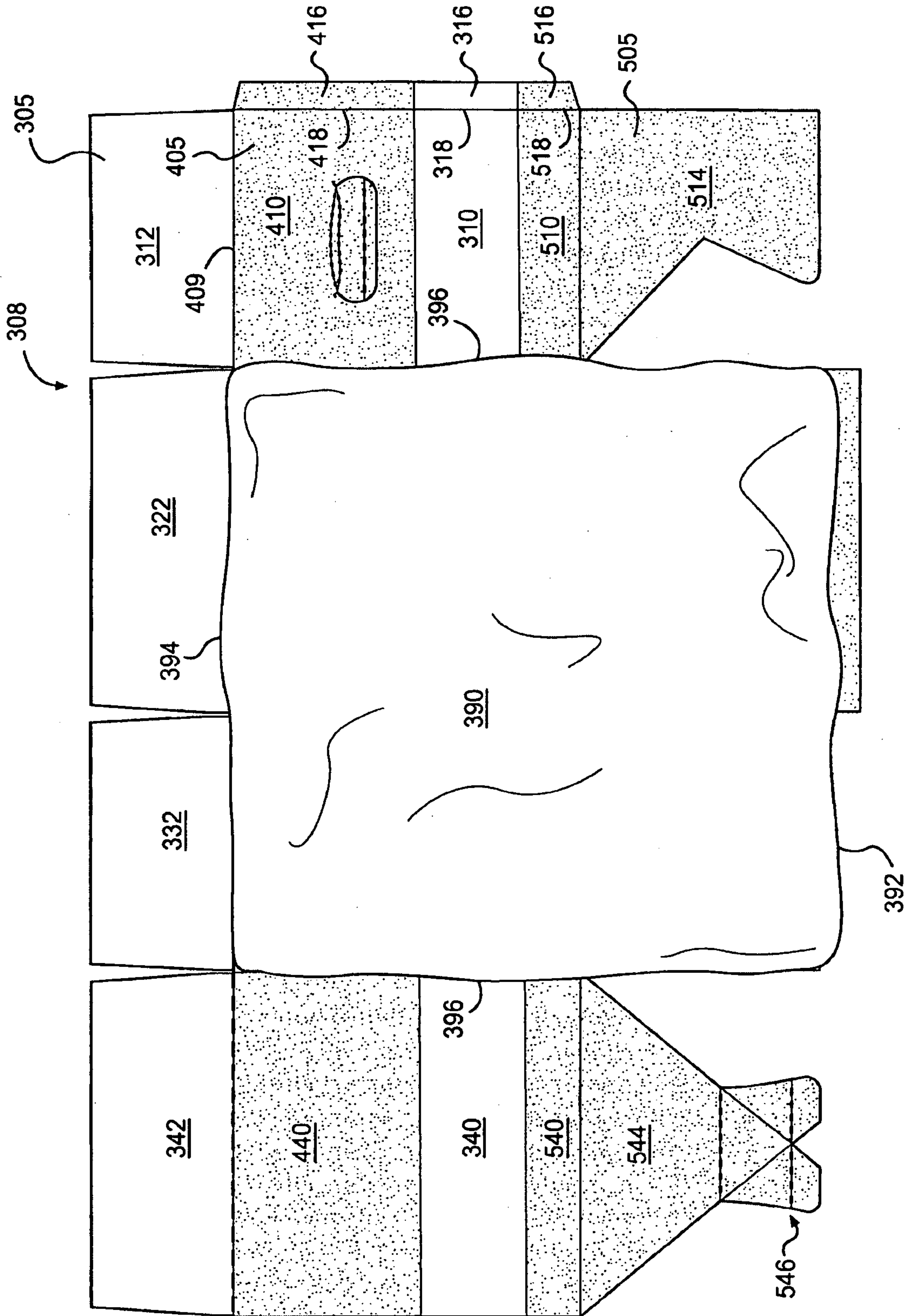

FIG. 11E

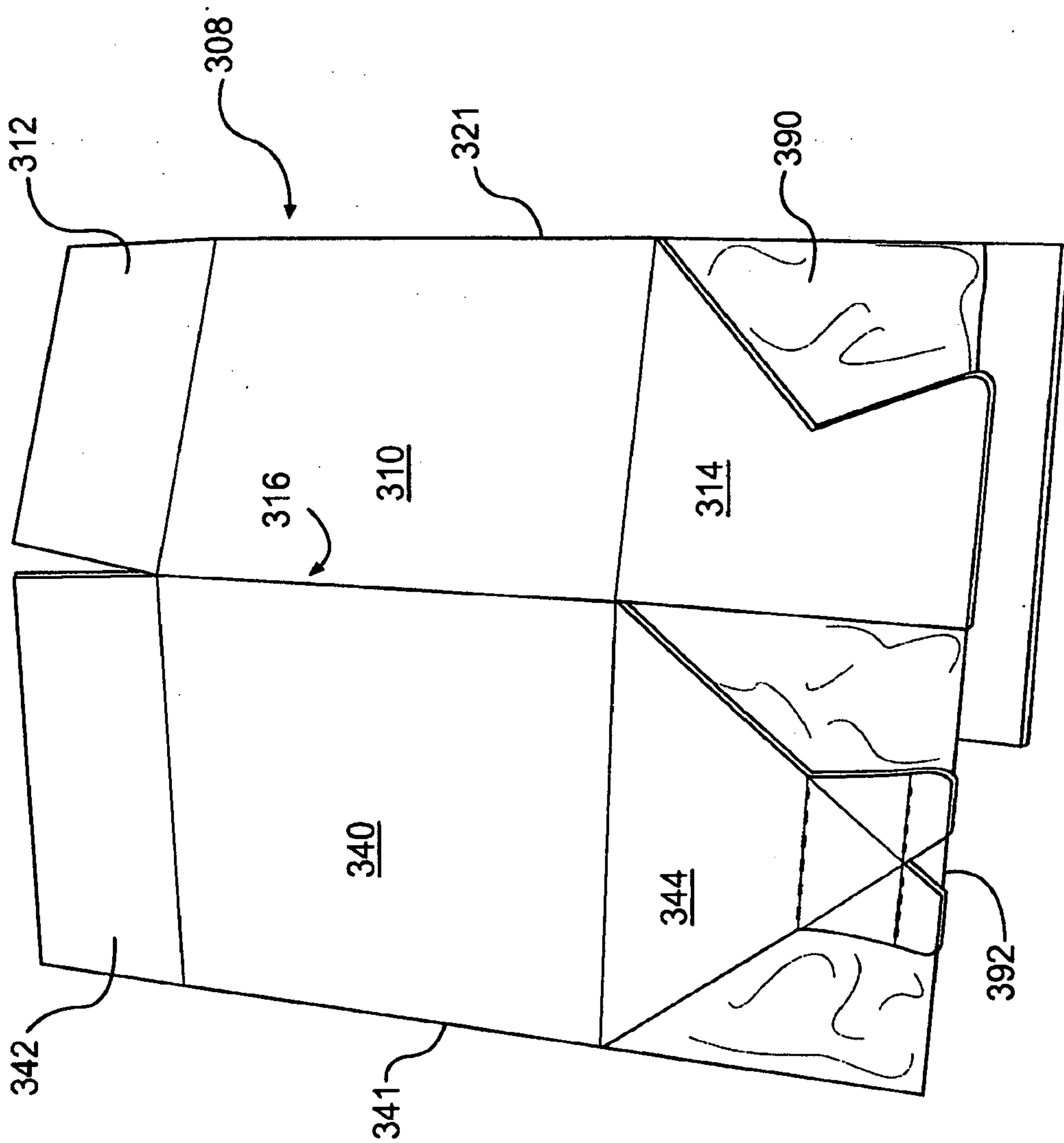

FIG. 12

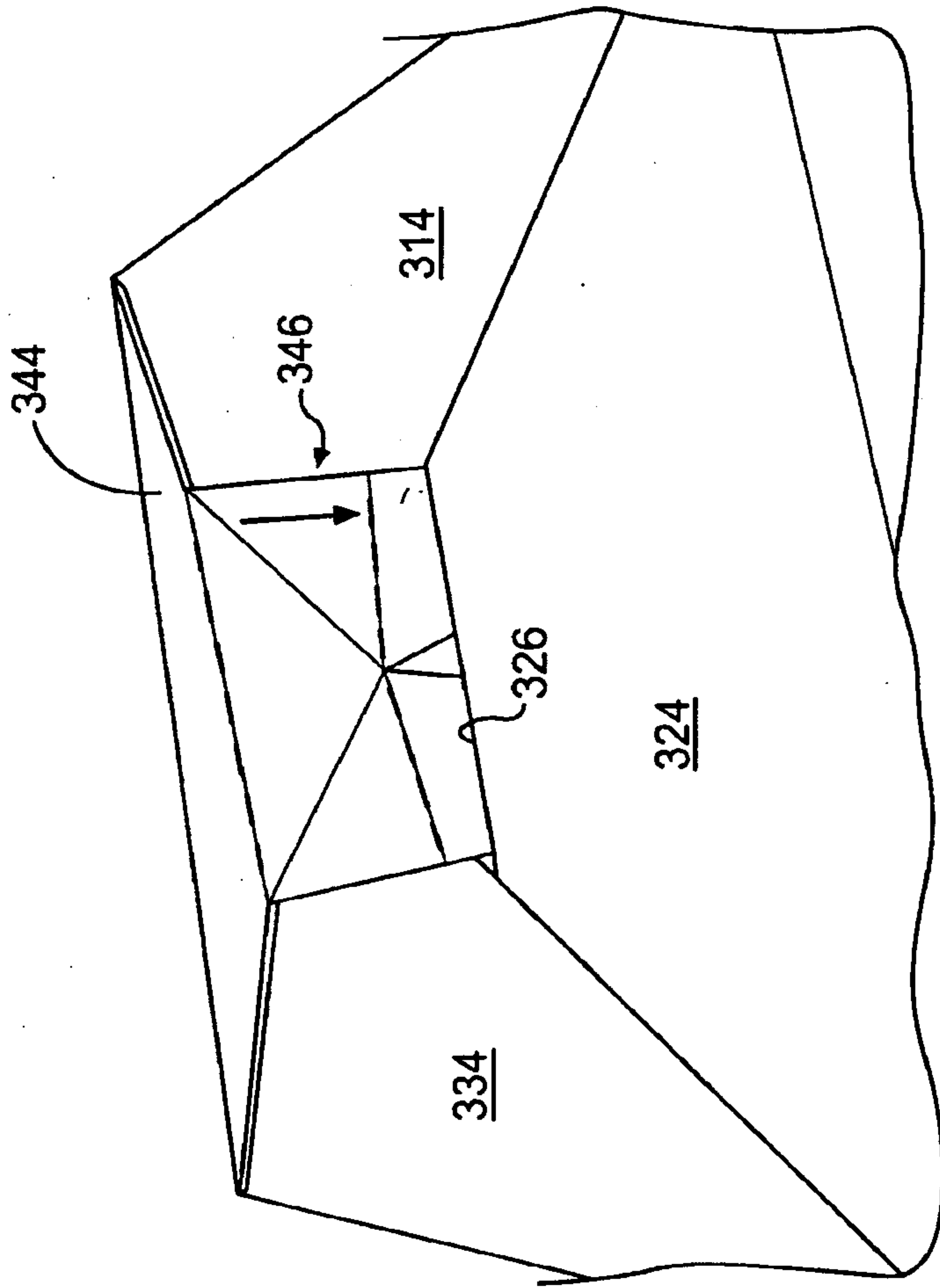

FIG. 13

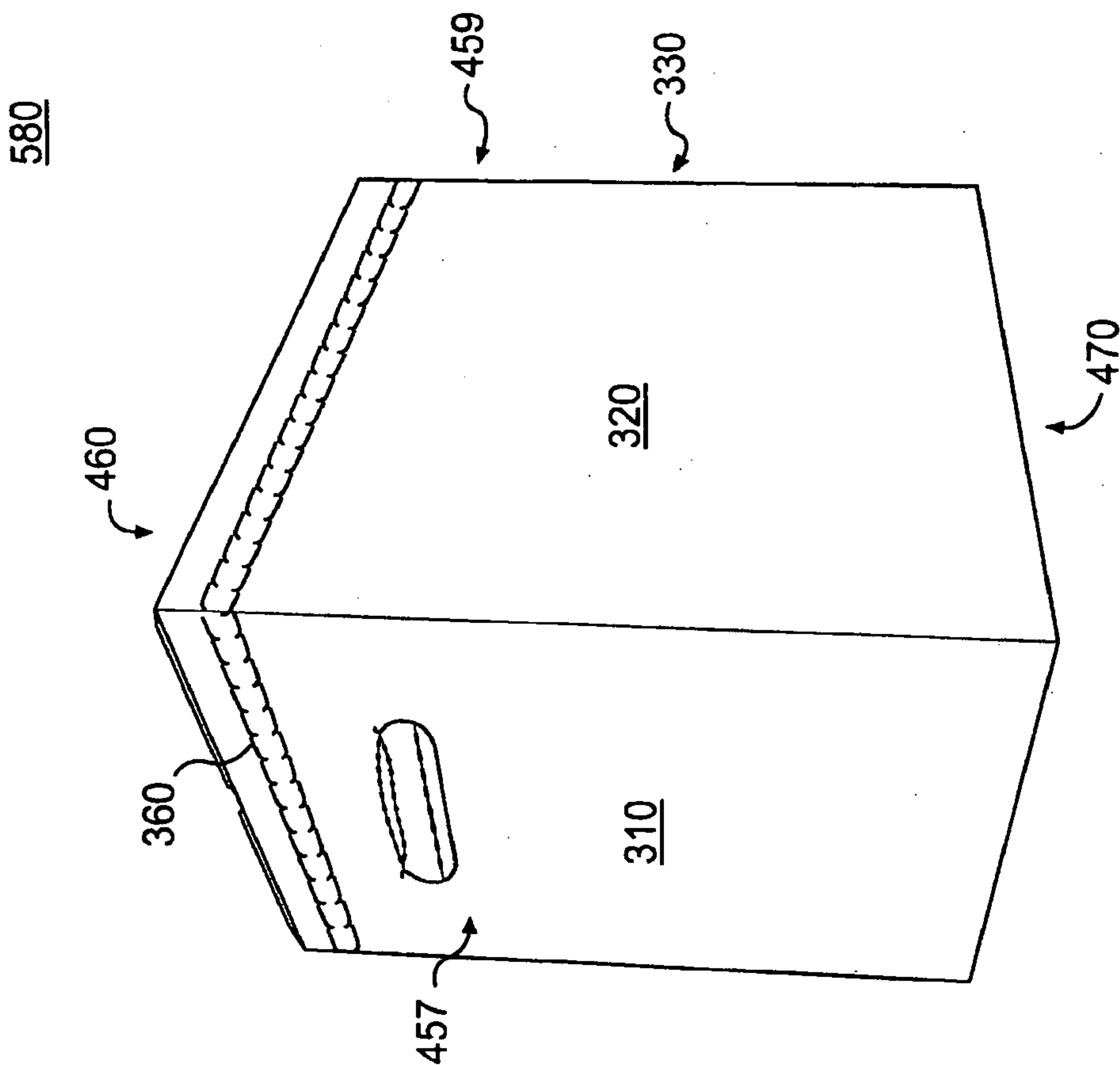

FIG. 14

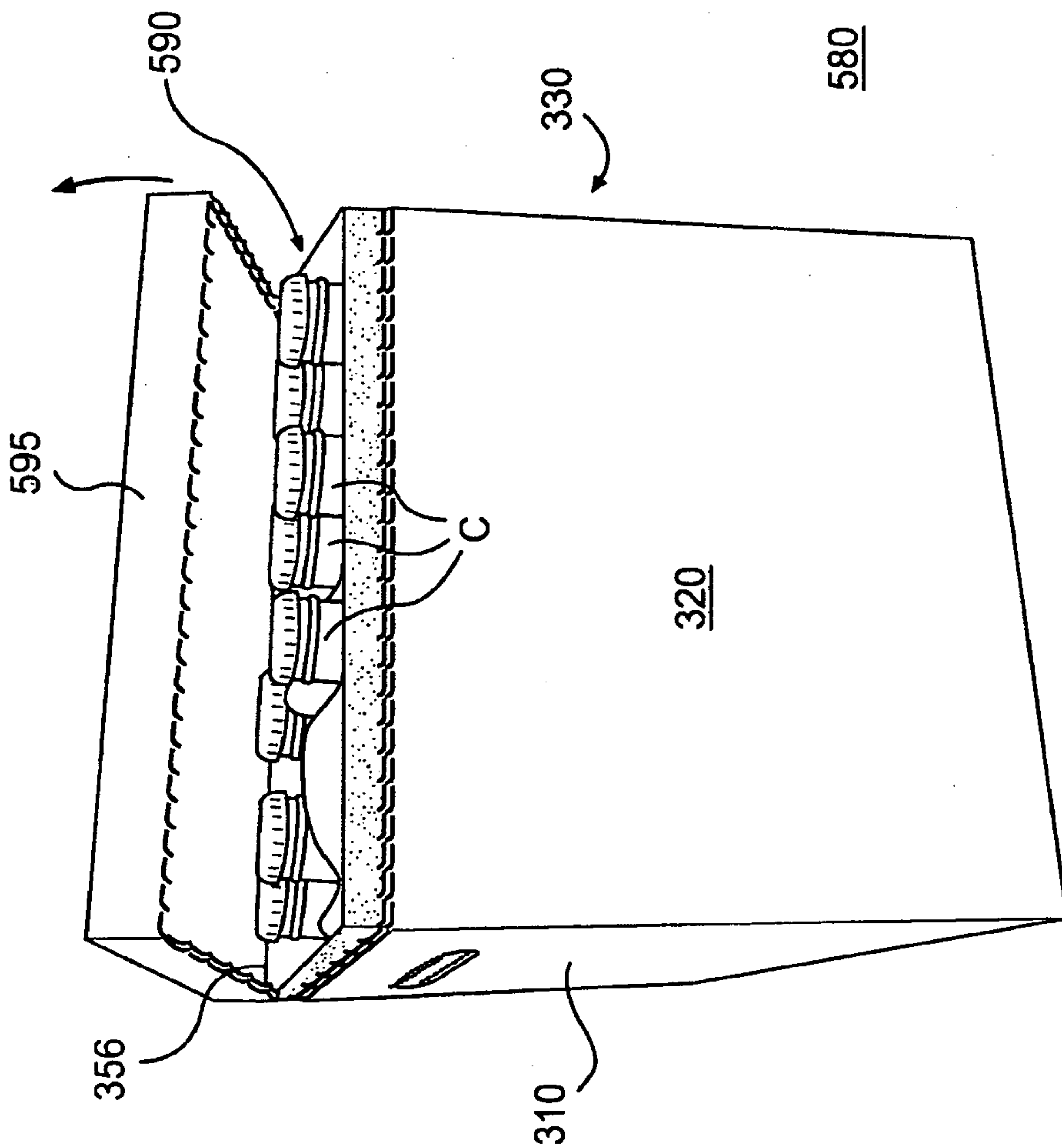

FIG. 15

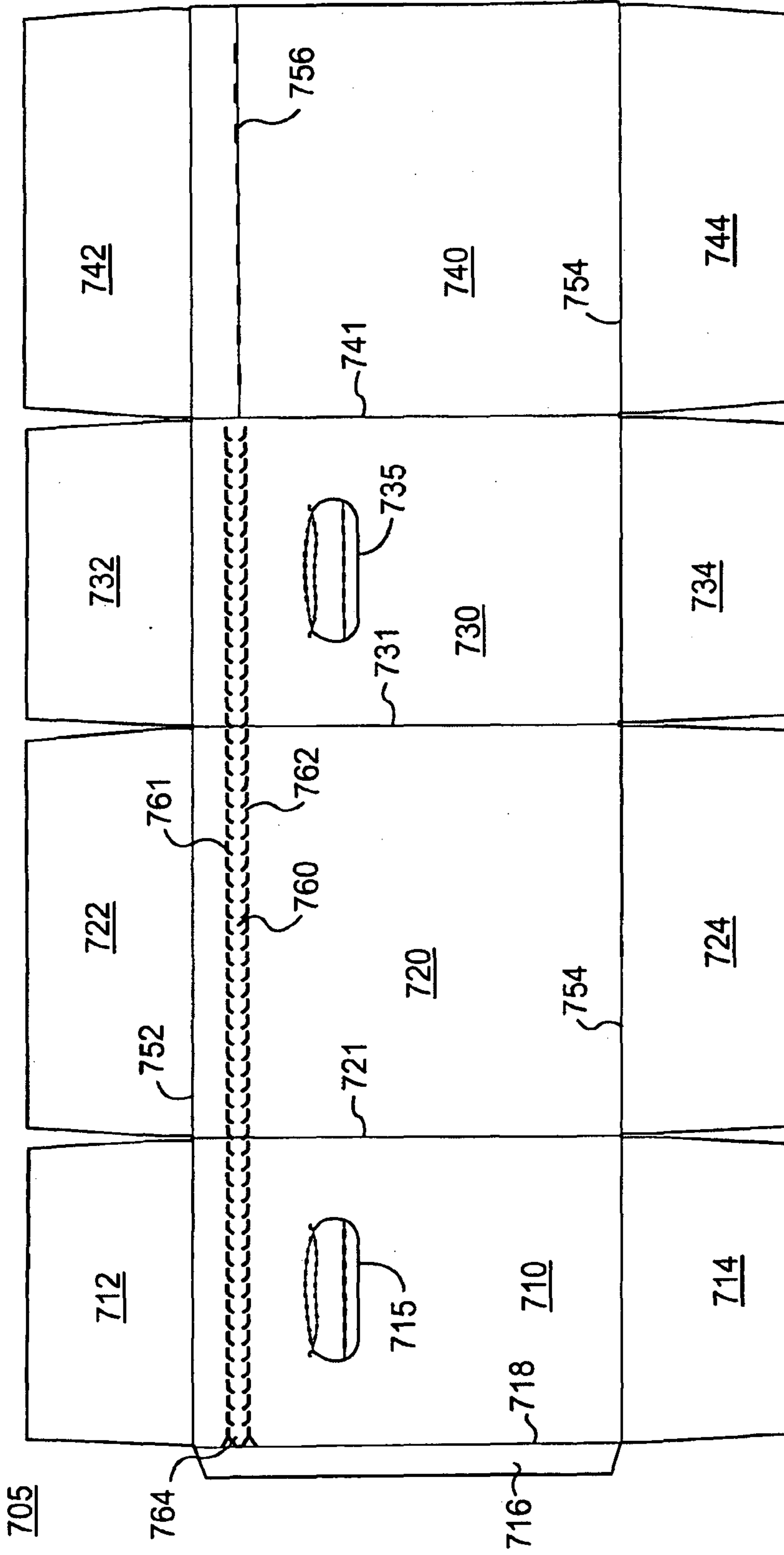

FIG. 16A

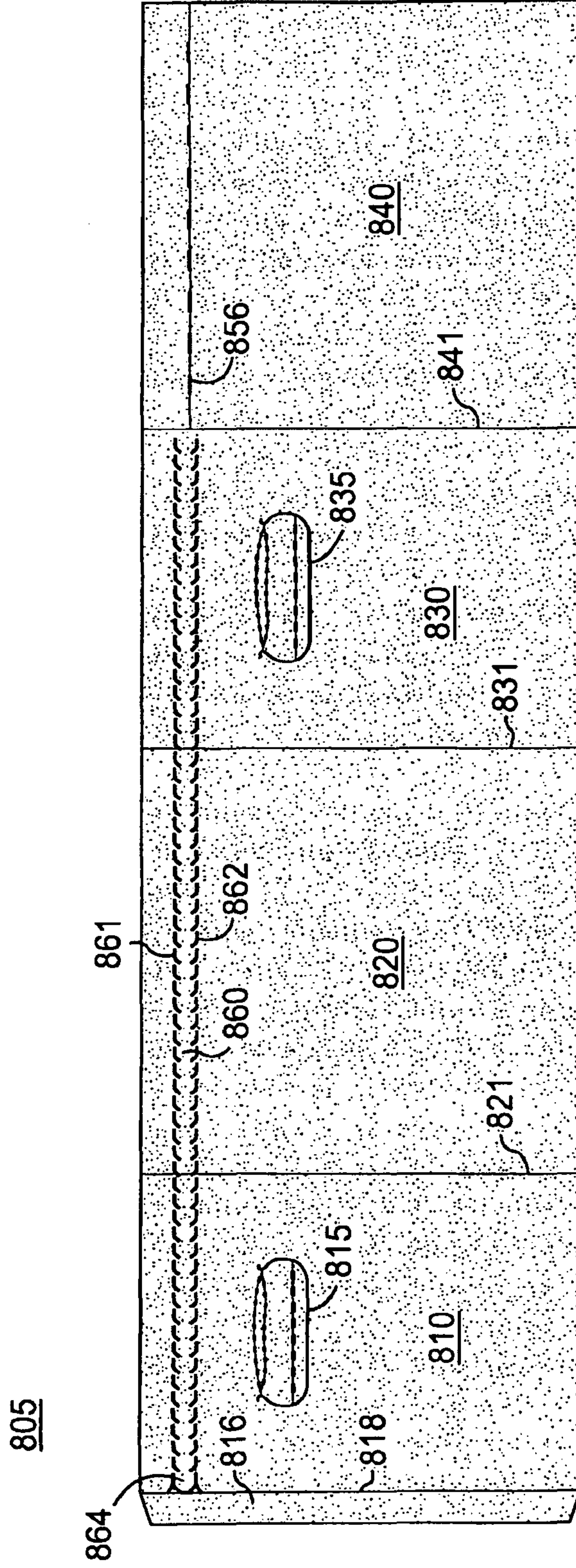

FIG. 16B

24/25

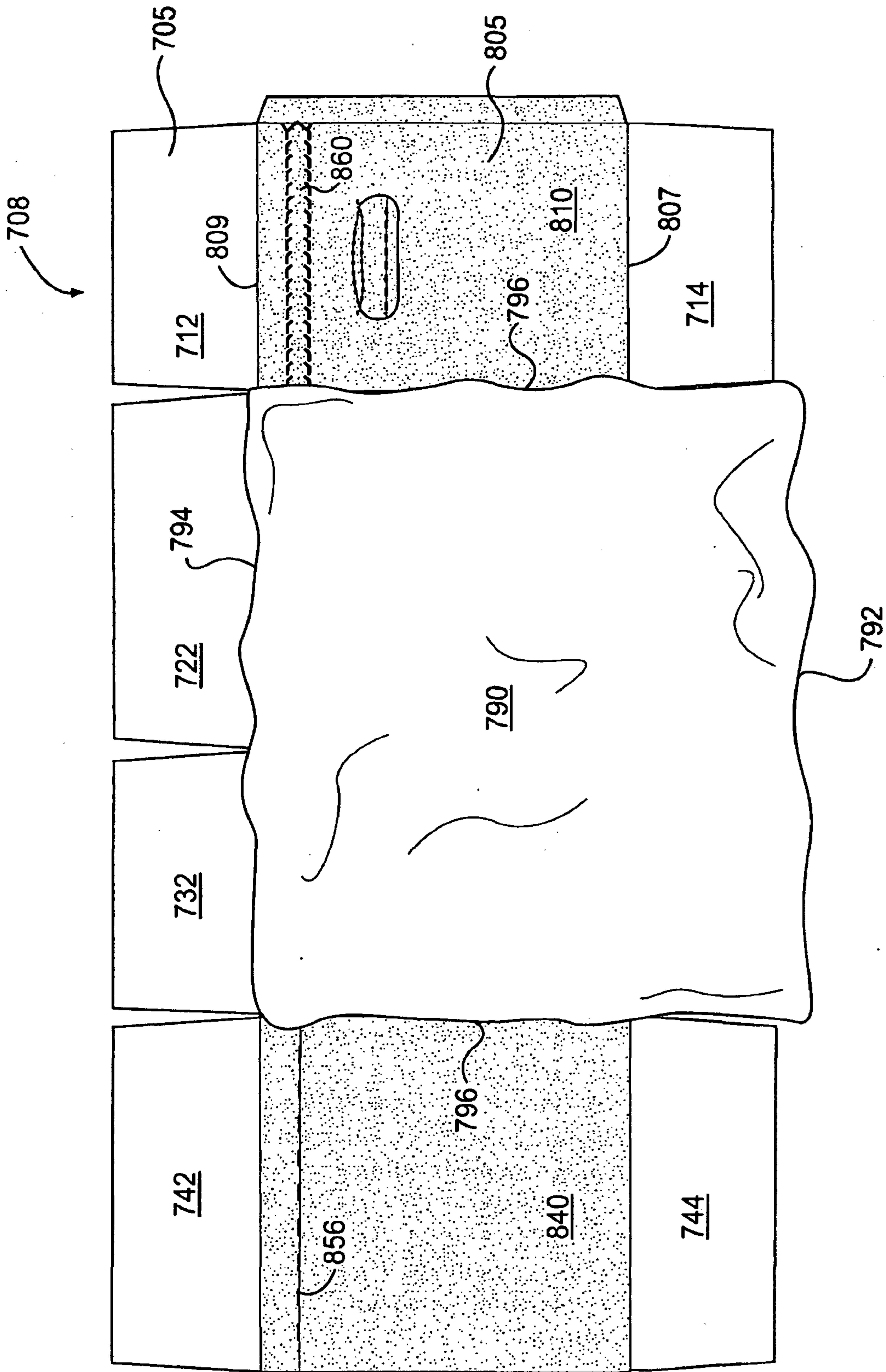

FIG. 16C

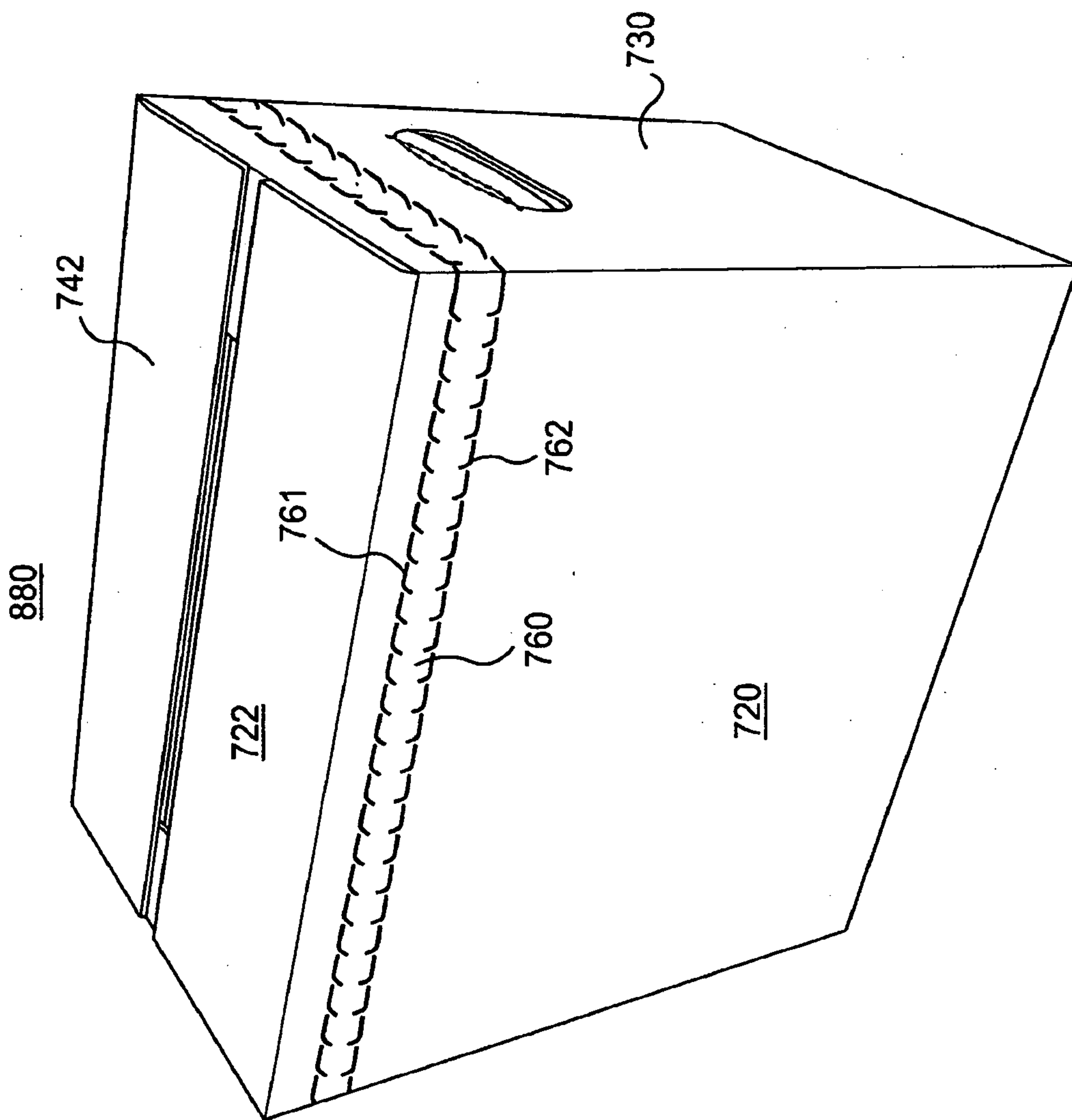

FIG. 17

