

(No Model.)

H. H. McLENATHAN.
EXTENSION SHELF.

No. 523,679.

Patented July 31, 1894.

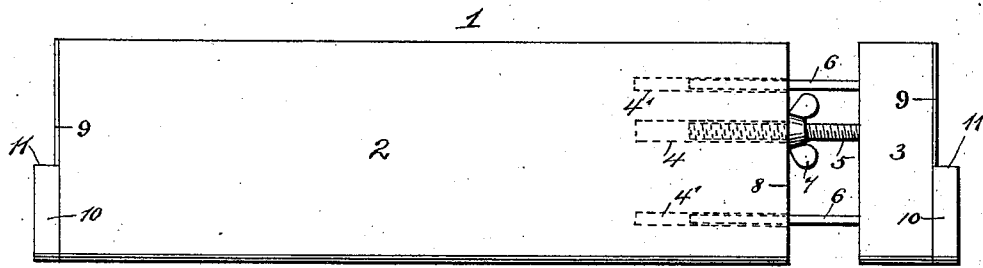

Fig. 1.

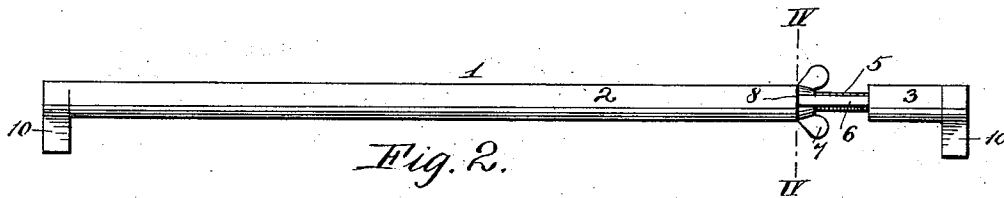

Fig. 2.

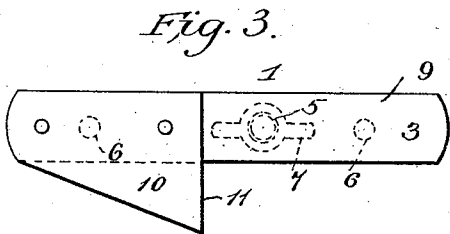

Fig. 3.

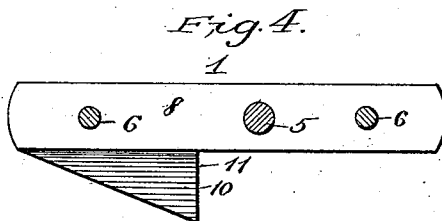

Fig. 4.

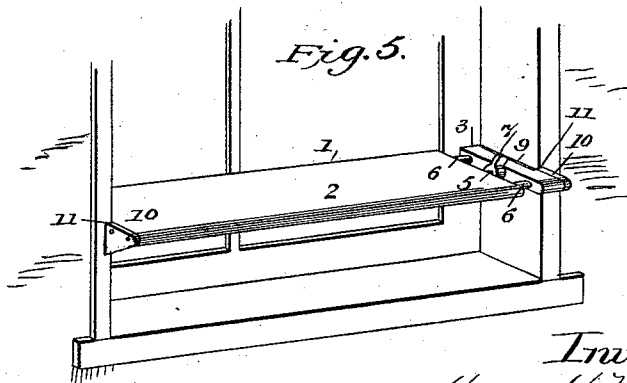

Fig. 5.

Witnesses.
Charles Parker.
Jos. H. Miland.

Inventor.
Harvey H. McLenathan
by Smith & Low
Attorneys.

UNITED STATES PATENT OFFICE.

HARVEY H. MCLENATHAN, OF ERVING, MASSACHUSETTS.

EXTENSION-SHELF.

SPECIFICATION forming part of Letters Patent No. 523,679, dated July 31, 1894.

Application filed November 2, 1893. Serial No. 489,786. (No model.)

To all whom it may concern:

Be it known that I, HARVEY H. MCLENATHAN, a citizen of the United States, residing at Erving, in the county of Franklin and State of Massachusetts, have invented certain new and useful Improvements in Extension-Shelves; and I do declare the following to be a full, clear, and exact description of the invention, such as will enable others skilled in the art to which it appertains to make and use the same.

My present invention relates to improvements in adjustable extension shelves which are adapted to be supported by contact between the shelves and any convenient surface with which the ends of the shelves may be caused to come in contact.

It particularly relates to shelves adapted to be placed and supported between the jambs of windows or in other similar places.

The objects of my improvements are to make a shelf which, although readily adjusted, is perfectly secure when in place and capable of sustaining a heavy weight; to furnish a light portable shelf and to produce a construction of greater simplicity and economy of manufacture.

With such objects in view my improvements consist in the novel parts and combinations thereof hereinafter more particularly set forth.

In order to make my improvements more clearly understood I have shown in the accompanying drawings means for carrying them into practical effect, without however intending to limit my improvements, in their useful applications, to the particular construction, which, for the sake of illustration I have delineated.

In said drawings:—Figure 1 is a plan view of a shelf provided with my improvements. Fig. 2 is a side and Fig. 3 an end elevation of the same. Fig. 4 is a sectional view in line IV—IV of Fig. 2. Fig. 5 is a perspective view on a smaller scale showing the shelf in place.

Referring to the drawings, 1 indicates a shelf formed in sections 2 and 3 in the adjacent faces of which are formed recesses 4 and 4' in the former of which is seated and longitudinally movable a screw-threaded shaft 5, and in the latter are movable guide and strengthening rods 6, 6 one end of each of

which may be secured to the section 3. On the shaft 5 is a thumb nut 7 bearing against the end 8 of the section 2. When this nut is turned in one direction it draws the shaft 5 outward thus forcing the section 3 away from the section 2, thereby lengthening the shelf. When turned in the other direction however it merely rides upon the shaft 5 away from the end 8 and the sections can be forced toward each other until the nut again encounters the end 8. On the ends of the shelf are friction-strips 9, 9, of any suitable material, such as india-rubber extending for only a portion of the width of the shelf.

10, 10 represent brackets or supports protruding outwardly and downwardly from the ends of the shelves. These brackets have substantially vertical faces 11, 11, which engage the front faces of the jambs of a window or analogous surfaces and prevent the shelf from tipping forward and eventually falling.

Having thus described my invention, what I claim is—

1. An extension shelf consisting of two or more sections and means for forcing said sections apart to cause their outer ends to encounter opposing surfaces, substantially as set forth.

2. As a new article of manufacture, an extension shelf formed in sections having in their adjacent faces recesses, guides seated in said recesses, and means for forcing said sections apart, substantially as set forth.

3. The combination with a shelf formed in sections having in their adjacent faces the recesses 4 and 4', of the shaft 5 and guide rods 6, seated respectively in said recesses 4 and 4' and the thumb nut on the shaft 5, substantially as and for the purposes described.

4. The combination with the shelf formed in sections, and means for forcing said sections apart, of the friction-strips 9, and the brackets 10 for preventing the shelf from tipping forward or slipping, substantially as set forth.

In testimony whereof I affix my signature in the presence of two witnesses.

HARVEY H. MCLENATHAN.

Witnesses:

GEORGE E. MONTEITH,
HENRY B. TULIPER.