



(51) International Patent Classification:

C02F 1/44 (2006.01) C02F 1/32 (2006.01)
B01D 61/02 (2006.01) C02F 1/28 (2006.01)
B01D 61/12 (2006.01)

(21) International Application Number:

PCT/EP2018/080227

(22) International Filing Date:

06 November 2018 (06.11.2018)

(25) Filing Language:

English

(26) Publication Language:

English

(30) Priority Data:

17200752.8 09 November 2017 (09.11.2017) EP

(71) Applicant (for all designated States except AE, AG, AU, BB, BH, BN, BW, BZ, CA, CY, EG, GB, GD, GH, GM, IE, IL, IN, JO, KE, KN, KW, LC, LK, LS, MT, MW, MY, NA, NG, NZ, OM, PG, QA, RW, SA, SC, SD, SG, SL, SZ, TT, TZ, UG, US, VC, ZA, ZM, ZW): **UNILEVER N.V.** [NL/NL]; Weena 455, 3013 AL Rotterdam (NL).

(71) Applicant (for AE, AG, AU, BB, BH, BN, BW, BZ, CA, CY, EG, GB, GD, GH, GM, IE, IL, IN, JO, KE, KN, KW, LC, LK, LS, MT, MW, MY, NA, NG, NZ, OM, PG, QA, RW, SA, SC, SD, SG, SL, SZ, TT, TZ, UG, VC, ZA, ZM, ZW only): **UNILEVER PLC** [GB/GB]; a company registered in England and Wales under company no. 41424 of Unilever House, 100 Victoria Embankment, London Greater London EC4Y 0DY (GB).

(71) Applicant (for US only): **CONOPCO, INC., D/B/A UNILEVER** [US/US]; 700 Sylvan Avenue (A4), Englewood Cliffs, New Jersey 07632 (US).

(72) Inventor: **KAMKAR, Kirtan, Shravan**; PLOT NO. 28, LADIKAR LAY OUT Manewada Road OPP SHIV MANDIR, Nagpur 440 024 MAHARASHTRA (IN).

(74) Agent: **REIJNS, Mr. Tiemen, Geert, Pieter**; Unilever Patent Group Olivier van Noortlaan 120, 3133 AT Vlaardingen (NL).

(81) Designated States (unless otherwise indicated, for every kind of national protection available): AE, AG, AL, AM, AO, AT, AU, AZ, BA, BB, BG, BH, BN, BR, BW, BY, BZ, CA, CH, CL, CN, CO, CR, CU, CZ, DE, DJ, DK, DM, DO, DZ, EC, EE, EG, ES, FI, GB, GD, GE, GH, GM, GT, HN, HR, HU, ID, IL, IN, IR, IS, JO, JP, KE, KG, KH, KN, KP, KR, KW, KZ, LA, LC, LK, LR, LS, LU, LY, MA, MD, ME, MG, MK, MN, MW, MX, MY, MZ, NA, NG, NI, NO, NZ, OM, PA, PE, PG, PH, PL, PT, QA, RO, RS, RU, RW, SA, SC, SD, SE, SG, SK, SL, SM, ST, SV, SY, TH, TJ, TM, TN, TR, TT, TZ, UA, UG, US, UZ, VC, VN, ZA, ZM, ZW.

(84) Designated States (unless otherwise indicated, for every kind of regional protection available): ARIPO (BW, GH, GM, KE, LR, LS, MW, MZ, NA, RW, SD, SL, ST, SZ, TZ, UG, ZM, ZW), Eurasian (AM, AZ, BY, KG, KZ, RU, TJ, TM), European (AL, AT, BE, BG, CH, CY, CZ, DE, DK, EE, ES, FI, FR, GB, GR, HR, HU, IE, IS, IT, LT, LU, LV, MC, MK, MT, NL, NO, PL, PT, RO, RS, SE, SI, SK, SM, TR), OAPI (BF, BJ, CF, CG, CI, CM, GA, GN, GQ, GW, KM, ML, MR, NE, SN, TD, TG).

Declarations under Rule 4.17:

- as to applicant's entitlement to apply for and be granted a patent (Rule 4.17(ii))
- as to the applicant's entitlement to claim the priority of the earlier application (Rule 4.17(iii))
- of inventorship (Rule 4.17(iv))

Published:

- with international search report (Art. 21(3))

(54) Title: A WATER DISPENSING DEVICE FOR DISPENSING WATER HAVING CONSISTENT TASTE

(57) Abstract: The present invention provides a water dispensing device for providing output water in a constant Total Dissolved solids (TDS) range, the device comprising: a. a feed water inlet in fluid communication with a water storage chamber; b. a reverse osmosis unit positioned downstream of the water storage chamber, the treatment unit having a treated water line and a reject water line; wherein, the reject water line is split by a multichannel connector into at least two lines, a recycle line and a drain line; wherein either a multi-way valve is positioned at the multichannel connector or one valve corresponding for every split line, a drain line valve on the drain line and a recycle line valve on the recycle line downstream of the multichannel connector; c. a TDS sensor positioned on the treated water line, adapted to measure TDS of the water flowing out of the treatment unit; d. an outlet positioned downstream of the treated water line for dispensing water; e. a control circuit configured to: i. store a threshold TDS value; and ii. drain water from the reject water line of the treatment unit through the drain line, when TDS value sensed is higher than the threshold TDS value, and alternately when the sensed value of TDS is less than or equal to the threshold value of TDS, directs water from the reject water line of the treatment unit into the recycle line and into the water storage chamber, when the device is in operation. The present invention also provides a process for providing output water from a water dispensing Device in a constant Total Dissolved solids (TDS) range and uses thereof.



A WATER DISPENSING DEVICE FOR DISPENSING WATER HAVING CONSISTENT TASTE

Field of the invention

The present invention relates to a water dispensing device. The present invention more particularly relates to a water dispensing Device which maintains total dissolved solids (TDS) in a given range in the output water which maintains the taste of output water almost constant irrespective of the variation in input TDS levels or any other variation in TDS which occur over a period of time in the dispensing device.

Background of the invention

There are various sources of input water into a water dispensing device and different sources may have different TDS levels which may affect the taste of output drinking water from the device. Also, over a period of time, due to continued usage of salt removal treatment units, the capability of a treatment unit to remove salts may vary and therefore, the output drinking water may differ in taste over a period of lifetime of the salt removal unit.

There are various salt removal treatment units used in water purifiers, of which Reverse Osmosis (RO) membranes are quite popular. RO devices work on the principle of reduction in dissolved solids from the input water. Water has a particular taste partly because of the dissolved solids. Removal of dissolved solids beyond a certain point may adversely affect the taste. Similarly, if higher amount of dissolved solids remain in the output water (also called permeate), the taste of water may still be unpalatable at least to some consumers. Therefore, in order to adjust the taste of permeate water, remineralization means are used in some RO devices. But that involves adding of minerals from another source and may increase the cost of the water purifier.

US7507334 B1 (SIGONA JON-ANDREW VINCENT, 2009) discloses a modular-filter based RO water treatment system that remineralizes purified water twice to ensure the water is alkaline, but uses only one remineralization filter made of calcite. Calcium carbonate causes drastic increase in total dissolved solids (TDS), which may render the

water unpalatable at least to some consumers. It also discloses that reverse osmosis filters remove on an average 98% sediments, organics and dissolved salts and reduce the pH to about 6.2 to 6.8 with only 5 to 15 ppm of dissolved salts. The remineralisation filter containing mineral calcite raises the pH to about 7.0 and dissolved salts to about 30
5 on an average and finally the pH to about 7.5 to 8.5 and total solids to 60 ppm.

WO 2013/034396 (Unilever) discloses that a cartridge comprising calcium carbonate and magnesium carbonate in a certain combination provides controlled increase in TDS irrespective of the TDS levels in the input water, thereby making the water palatable.

The cited prior art does not disclose how to maintain uniform TDS level in the output
10 water that has been purified using a reverse osmosis process where there is significant variation in the TDS levels of the input water. This is important considering the fact that there may be significant variation in the TDS levels from various sources of water and over the lifetime of the water purifier.

JP2011-025114A (Duskin Co Ltd) discloses a water purifier having a raw water tank, an
15 RO membrane, a raw water TDS sensor and a pure water TDS sensor. The concentrate is recycled through recirculation line and is returned into the raw water tank through return line. The concentrate may be drained or flushed through drain line by actuating a three-way valve, located upstream of return line. Based on the input from the two TDS sensors, the purifier can select the water source (either 100% tap water or raw water
20 from raw water tank).

EP0599281, discloses a process for the treatment of liquids according to the principle of reverse osmosis, in particular for the recovery of substantially pure water from tap water, brackish water or salt water by means of a membrane module having a device. This design of a device providing recirculation of reject water can easily harm the device and
25 the RO membrane as there will be intermittent pressure drop.

The disclosure of the application however does not disclose a solution to output water in the desired range, it only utilizes the TDS sensor to decide switching between the water source.

Therefore, there is a need to provide a device and method capable of achieving any constant TDS range value irrespective of the input/feed water TDS value.

Summary of the invention

5 The present invention provides a water dispensing device for providing output water in a constant Total Dissolved solids (TDS) range and which also helps in minimizing wastage of water.

First aspect of the present invention provides a water dispensing device for providing output water in a constant Total Dissolved solids (TDS) range, the device comprising:

- 10 a. a feed water inlet in fluid communication with a water storage chamber;
- 10 b. a water treatment unit positioned downstream of the water storage chamber, the treatment unit having a treated water line and a reject water line;
wherein, the reject water line is split by a multichannel connector into at least two lines, a recycle line and a drain line; wherein either a multi-way valve is positioned at the multichannel connector or one valve corresponding for every split line, a drain line valve on the drain line and
15 a recycle line valve on the recycle line downstream of the multichannel connector;
- 20 c. a TDS sensor positioned on the treated water line, adapted to measure TDS of the water flowing out of the treatment unit;
- 20 d. d. an outlet positioned downstream of the treated water line for dispensing water;
- 25 e. a control circuit configured to:
 - i. store a threshold TDS value; and
 - ii. drain water from the reject water line of the treatment unit through the drain line, when TDS value sensed is higher than the threshold TDS value, and alternately when the sensed value of TDS is less than or equal to the threshold value of TDS, directs water from the reject water line of the treatment unit into the recycle line and into the water storage chamber;
- 30 when the device is in operation.

Second aspect of the present invention provides a method for providing output water in a constant TDS range by the device according to the first aspect, the method comprising,

- i. providing an inlet water flow through inlet into the water storage chamber;
- ii. allowing water to pass from the water storage chamber into the treatment unit;
- 5 iii. sensing TDS of the water in the treated water line by the TDS sensor;
- iv. comparing the TDS sensed in step (iii) with the stored threshold TDS value; and
- v. draining water from the reject water line of the treatment unit through the drain line, when TDS value sensed is higher than the threshold TDS value, and
10 alternately directing water from the reject water line of the treatment unit into the recycle line and into the water storage chamber when the sensed value of TDS is less than or equal to the threshold value of TDS to obtain the output water in a constant TDS range.

Another aspect of the present invention provides use of the device according to first
15 aspect for minimizing waste water

Another aspect of the present invention provides a provides use of the device according to first aspect for maintaining TDS of output water from the device in a constant range.

Another aspect of the present invention provides a use of a control circuit configured to drain water from reject water line of a treatment unit through the drain line, when TDS
20 value sensed is higher than the threshold TDS value, and alternately when the sensed value of TDS is less than or equal to the threshold value of TDS, directs water from the reject water line of the treatment unit into the recycle line and into a water storage chamber,

in a water dispensing device comprising:

- 25 a. a feed water inlet in fluid communication with a water storage chamber;
- b. a water treatment unit positioned downstream of the water storage chamber, the treatment unit having a treated water line and a reject water line;
wherein, the reject water line is split by a multichannel connector into at least two lines, a recycle line and a drain line; wherein either a multi-
30 way valve is positioned at the multichannel connector or one valve corresponding for every split line, a drain line valve on the drain line and

- a recycle line valve on the recycle line downstream of the multichannel connector;
- c. a TDS sensor positioned on the treated water line, adapted to measure TDS of the water flowing out of the treatment unit;
- 5 d. d. an outlet positioned downstream of the treated water line for dispensing water;

for minimizing waste water.

Another aspect of the present invention provides a use of a control circuit configured to drain water from reject water line of a treatment unit through the drain line, when TDS value sensed is higher than the threshold TDS value, and alternately when the sensed value of TDS is less than or equal to the threshold value of TDS, directs water from the reject water line of the treatment unit into the recycle line and into a water storage chamber;

10

in a water dispensing device comprising:

- 15 a. a feed water inlet in fluid communication with a water storage chamber;
- b. a water treatment unit positioned downstream of the water storage chamber, the treatment unit having a treated water line and a reject water line;

wherein, the reject water line is split by a multichannel connector into at least two lines, a recycle line and a drain line; wherein either a multi-way valve is positioned at the multichannel connector or one valve corresponding for every split line, a drain line valve on the drain line and a recycle line valve on the recycle line downstream of the multichannel connector;

20

- 25 c. a TDS sensor positioned on the treated water line, adapted to measure TDS of the water flowing out of the treatment unit;
- d. an outlet positioned downstream of the treated water line for dispensing water;

for maintaining TDS of output water from the device in a constant range.

30 These and other aspects, features and advantages will become apparent to those of ordinary skill in the art from a reading of the following detailed description and the appended claims.

BRIEF DESCRIPTION OF DRAWINGS

The invention will now be described into more detail with reference to the accompanying drawings whereby

Figure 1 and 2 show the water flow diagram of the present invention.

5 Detailed description of the invention

For the avoidance of doubt, any feature of one aspect of the present invention may be utilised in any other aspect of the invention. The word "comprising" is intended to mean "including" but not necessarily "consisting of" or "composed of." In other words, the listed steps or options need not be exhaustive. It is noted that the examples given in the
10 description below are intended to clarify the invention and are not intended to limit the invention to those examples *per se*.

Except in the operating and comparative examples, or where otherwise explicitly indicated, all numbers in this description indicating amounts of material or conditions of reaction, physical properties of materials and/or use are to be understood as modified
15 by the word "about".

Numerical ranges expressed in the format "from x to y" are understood to include x and y. When for a specific feature multiple preferred ranges are described in the format "from x to y", it is understood that all ranges combining the different endpoints are also contemplated.

20 As used herein, the indefinite article "a" or "an" and its corresponding definite article "the" means at least one, or one or more, unless specified otherwise.

Water treatment units such as reverse osmosis (RO) devices or other desalination devices are conventionally used at places where the total dissolved solids (TDS) of water are high. However, nowadays, such devices are also being used at places where the
25 TDS may not be high. Generally, the TDS of surface water e.g., water that comes from lakes and reservoirs ranges from 70 to 120 ppm. On the other hand, TDS of river or stream water ranges from 250 to 500 ppm. At some places, underground water, e.g.

bore-well water is supplied. This water, by far, has very high TDS which may range from 500 to 2000 ppm.

While some amount of dissolved solids lend water its characteristic taste. TDS less than 25 ppm or more than 200 ppm may make it unpalatable to some consumers.

- 5 Reverse osmosis (RO) is a membrane filtration method that removes many types of large molecules and ions from solutions by applying pressure to the solution when it is on one side of a selective membrane. The result is that the solute is retained on the pressurized side of the membrane and the pure solvent is allowed to pass to the other side. To be "selective," this membrane should not allow large molecules or ions through the pores
10 (holes), but should allow smaller components of the solution (such as water) to pass freely.

In the normal osmosis process the solvent naturally moves from an area of low solute concentration, through a membrane, to an area of high solute concentration. The movement of a pure solvent to equalize solute concentrations on each side of a
15 membrane generates osmotic pressure. Applying an external pressure to reverse the natural flow of pure solvent, thus, is reverse osmosis. Reverse osmosis, however, involves a diffusive mechanism so that separation efficiency is dependent on solute concentration, pressure, and water flux rate. Reverse osmosis is most commonly known for its use in drinking water purification from seawater, removing the salt and other
20 substances from the water molecules.

Conventional RO membranes are known to remove about 90% TDS from the input water. Therefore, in some cases, the output water (permeate) may have as low as 4 to 5 ppm TDS which may be perceived unacceptably bitter. On the other hand, if the TDS of input water is about 2000 ppm; the permeate having TDS more than 200 ppm may be
25 perceived salty.

Therefore, in order to balance the TDS of the permeate water, some RO devices use remineralisation means.

It was a surprising finding that the water dispensing device of the present invention with the given flow path of water and the control circuit configured to drain water from the reject water line of the treatment unit through the drain line, when TDS value sensed is higher than the threshold TDS value, and alternately when the sensed value of TDS is less than or equal to the threshold value of TDS, to direct water from the reject water line of the treatment unit into the recycle line and into the water storage chamber; it was seen that the TDS of the output water of the device was in a constant range and the device of the present invention also contributed to minimizing the wastage of water by allowing recycling of water through the reject water line of the treatment unit.

The invention also provides a device that works dynamically to continuously sense the TDS levels of the output water and then take action to ensure that the taste of the output water remains nearly constant and palatable to the consumer throughout the life of the water dispensing Device, the treatment unit and irrespective of the source of water used. The device of the present invention is also beneficial for providing water with desirable TDS levels by the same device in different regions and localities irrespective of the input TDS water levels used as feed water into the device.

It was also a surprising finding and a benefit of the present invention that the device is capable of dispensing water which is even higher than the input/feed water TDS.

The preferred constant TDS range of drinking water is desirable between 30 to 250 ppm, more preferably between 50 to 150 ppm and most preferably between 70 to 120 ppm which can be achieved by the device of the present invention by using the threshold TDS value in the range of 30 to 250 ppm, more preferably between 50 to 150 ppm and most preferably between 70 to 120 ppm.

However, the device and method of the present inventions is capable of achieving any constant TDS range value irrespective of the input/feed water TDS value. This can be done by choosing an appropriate threshold value of TDS. Another advantage of the device is that for the same device, the desired TDS of the output water from the device can be varied as per the requirement or taste of the consumer simply by varying the threshold TDS value. The device of the present invention is therefore capable of being employed in any industry where a constant range of TDS of the output water is desired.

The present invention is also useful for providing any desired TDS range, which may not be necessarily used for drinking but any other desired purpose, wherein the treatment unit could be any industrial treatment unit. This would ensure that irrespective of the feed water source or the treatment that the feed water undergoes inside a water dispensing device, the TDS of the output water can be in a desired range.

The Water Dispensing Device

The present invention provides a water dispensing device for providing output water in a constant Total Dissolved solids (TDS) range, the device comprising:

- a. a feed water inlet in fluid communication with a water storage chamber;
 - 10 b. a water treatment unit positioned downstream of the water storage chamber, the treatment unit having a treated water line and a reject water line;
wherein, the reject water line is split by a multichannel connector into at least two lines, a recycle line and a drain line; wherein either a multi-way valve is positioned at the multichannel connector or one valve corresponding for every split line, a drain line valve on the drain line and
15 a recycle line valve on the recycle line downstream of the multichannel connector;
 - c. a TDS sensor positioned on the treated water line, adapted to measure TDS of the water flowing out of the treatment unit;
 - 20 d. an outlet positioned downstream of the treated water line for dispensing water;
 - e. a control circuit configured to:
 - i. store a threshold TDS value; and
 - ii. drain water from the reject water line of the treatment unit through the drain line, when TDS value sensed is higher than the threshold TDS
25 value, and alternately when the sensed value of TDS is less than or equal to the threshold value of TDS, directs water from the reject water line of the treatment unit into the recycle line and into the water storage chamber;
when the device is in operation.
- 30 It is highly preferred that the threshold value of TDS ranges from 10 to 2000 ppm, more preferably from 15 to 1000 ppm and most preferably from 20 to 500 ppm.

It is preferred that upstream of the treatment unit is positioned a mechanical unit for driving water into the treatment unit.

The water dispensing device is preferably a water purification device dispensing purified water. It may preferably also have a sediment filter for pre-treatment generally placed
5 before the treatment unit. Such filters may be made of woven or non-woven cloth or a carbon block. The fabric may be made of natural fibers or of synthetic origin. Non-woven cloth made of cotton, polyester, polypropylene, or nylon is preferred. A typical carbon block includes bound activated carbon particles.

It is also highly preferred to have purification units post the treatment unit such as UV
10 treatment unit and/or a post carbon block and the ones common in the industry of water purification.

A feed water inlet

A feed water inlet is an inlet for providing water to the water dispensing device for purification and/or treatment and may have a varying variety of feed water entering into
15 the device through the inlet. The inlet is in fluid communication with a water storage chamber. The feed water inlet can provide water from various sources which may have any TDS value.

Water Storage chamber

A water storage chamber is preferably positioned downstream of the feed water inlet and
20 in fluid communication with the feed water inlet. The water storage chamber is preferably used for storing raw water, that is water before it is treated in the treatment unit. The water storage chamber serves two purposes, one of storing the raw water and another of serving as a chamber to receive the water from the recycle line. The water storage chamber is in fluid communication with the recycle line.

25 It is preferable that the water storage chamber has at least one means to maintain volume of the chamber, preferably a valve and most preferably a float type valve. It is most preferable to have more than one float valves in the water storage chamber.

A water treatment unit

A water treatment as a component of the device of the present invention could be a unit for treating water in any sense, and is used broadly to mean bringing out any change in the composition of water which is dispensed out of the device for use. It is preferred that
5 the treatment unit in some manner alters the TDS content of the raw water. It is more preferred that the treatment unit is a desalination unit and most preferably a reverse osmosis unit.

The treatment unit is positioned downstream of the water storage chamber and has a reject water line; wherein, the reject water line is split by a multichannel connector into
10 at least two lines, a recycle line and a drain line; wherein either a multi-way valve is positioned at the multichannel connector or one valve corresponding for every split line, a drain line valve on the drain line and a recycle line valve on the recycle line downstream of the multichannel connector, such that preferably at a given time water flows through only one split line.

15 The treated water from the treatment unit flows out through the treated water line which may further be treated or processed or may be dispensed through the outlet for dispensing water.

The treatment unit therefore has at least two lines for the water to flow out from it, the treated water line and the reject water line. The reject water line is further split by a
20 multichannel connector into at least two lines, a recycle line and a drain line. A multichannel connector preferably serves the purpose to split the reject water line into higher number of lines of which minimum is two. The multichannel connector could be a separate part used for connecting the reject water line with the different lines into which it is split or it may be molded as a single piece splitting into different lines. A multi-way
25 valve could be positioned at the multichannel connector or a separate valve could be present corresponding to each split line emanating from the reject water line of the water treatment unit, such as a drain line valve on the drain line and a recycle line valve on the recycle line downstream of the multichannel connector, such that preferably at a given time water flows through only one split line.

It is highly preferable that the recycle is provided with a flow restrictor downstream of the valve positioned at the multichannel connector or the recycle valve as the case may be. The flow restrictor helps in limiting or restricting the flow of the water flowing through the recycle line, such that at a given time if water simultaneously flows through the drain line and the recycle line, then the amount of water to be recycled could be controlled through the flow restrictor. It is furthermore preferable to have a flow restrictor on the drain line as well.

When the treatment unit is a reverse osmosis (RO) unit, then the unit comprises a reverse osmosis (RO) membrane. RO membranes are commercially available for industrial and domestic use. The RO membranes may be made in a variety of configurations, with the most preferred configuration being the TFC (thin film composite). A preferred RO membrane is FILMTEC™ Membranes Product TW30-1812-50 from The Dow Chemical Company.

A Total Dissolved Solids (TDS) sensor

The device the present invention includes a 'total dissolved solids' (TDS) measuring means or a Total Dissolved Solids (TDS) sensor positioned on the treated water line, adapted to determine the total dissolved solids adapted to measure TDS of the water flowing out of the treatment unit; and communicating the measured value to the control circuit.

The TDS sensor is therefore positioned downstream of the treatment unit and is adapted to measure the TDS of water on the treated water line when the device is in operation.

The term "dissolved solids" refers generally to any minerals, salts, metals, cations or anions that are dissolved in a water sample. Dissolved solids include many of the substances that impair water color, odor, taste, or overall water quality. Many industries, and the food service industry in particular, require that the water used be held to stringent standards such that the color, odor, or taste of the water does not have any adverse effect on the end product.

A TDS sensor may be of any type being capable of sensing or measuring the total dissolved solids. A commonly used TDS meter displays the TDS in parts per million (ppm). For example, a TDS reading of 1 ppm would indicate there is 1 milligram of dissolved solids in 1 kilogram of water. It possible to estimate the TDS level by measuring
5 the electrical conductivity (EC) of the water with a meter and converting. A TDS meter may be an EC meter converting an EC reading to represent the TDS in the sample. Some meters can be selected to display either value.

Control circuit

The device of the present invention includes a control circuit preferably configured to
10 control the various components of the device. The control circuit can be either manually or automatically controlled.

The control circuit is configured to store a threshold TDS value; and drain water from the reject water line of the treatment unit through the drain line, when TDS value sensed is higher than the threshold TDS value, and alternately when the sensed value of TDS is
15 less than or equal to the threshold value of TDS, directs water from the reject water line of the treatment unit into the recycle line and into the water storage chamber.

It is also highly preferable that the control circuit is configured to cover a TDS threshold value in a range spanning +/- 10% value of the predetermined TDS value.

Preferably the control circuit comprises a memory. It preferably, includes a simple
20 feedback circuitry or a microprocessor. Preferably the microprocessor control system is a programmable loop controller (PLC) system capable of monitoring the resistance, impedance, or conductance of the electrodes to enable the adjusting of power output to the electrodes via a connection. Preferably the microprocessor system is associated with software adapted to drive the microprocessor control system.

25 Alternatively, the control circuit may be an analogue system utilising comparators or a digital system without a microprocessor.

The device of the present invention preferably has a flow rate detection means and/or a pressure detecting means adapted to measure the volume of liquid flowing through the

device and/or detect the pressure of water entering the ion-eluting unit and communicating the measured value to the control circuit.

Preferably there is a flow rate and/or pressure detecting means adapted to detect the flow or pressure of water entering the device to switch the system on or off in the presence or absence of the flow of water in the device. It is preferred that the flow and/or pressure detecting means can be associated with a timer adapted also to switch the system on and off.

Preferably there is a flow control circuit for controlling the rate of flow of liquid through the device. For example, the flow control unit may be connected to one or more pumps and/or one or more valves controllable to vary the flow of the water through the device.

Preferably the control circuit includes a constant current circuitry which are well known to a person skilled in the art, any known constant current circuitry may be used for the purpose which measures and/or stores the TDS values and compare the stored threshold TDS values with the real-time sensed TDS values.

It is preferred that the control circuit is further configured to include 10% variation of the threshold TDS value in calculation of the threshold TDS value.

The control circuit stores a threshold value of TDS and compares with the real-time TDS data sensed by TDS sensor, with the stored threshold TDS value. If the sensed TDS value at a given time is higher than the threshold TDS value, then the water from the treatment unit is drained into the drain line via the reject water line. On the other hand, if the sense value of TDS is lower than the stored threshold TDS value at a given time, then the water from the treatment unit is directed into the recycle line from the reject water line of the water treatment unit and subsequently into the water storage chamber when the device is in operation.

The control circuit preferably operably controls the multi-way valve positioned on the multichannel connector when present or the corresponding drain line valve and recycle line valves when present. When the water from the reject water line needs to be drained the flow of water into the recycle line is closed by operably closing the recycle valve or stopping the flow of water into the recycle line, by operably closing the flow of water through the multi-way valve into the recycle line. Similarly, when water from the reject

water line needs to be recycled the flow of water into the drain line is closed by operably closing the drain valve or stopping the flow of water into the drain line, by operably closing the flow of water through the multi-way valve into the drain line.

5 The control circuit may further be configured to allow the permeate line water into the water storage tank.

10 The device of the present invention is also capable of partial recycle by having one or more split lines emanating from the reject water line. It is also possible to have both the recycle line and the drain line open simultaneously but having flow restrictors on at least one and preferably all the lines which distribute the flow of water appropriately between the drain line and the recycle line and any other when that is present. This allows specific percentages of water to flow out from different lines. Such as 30% water flows out from drain line and 70% from recycle line or vice versa.

Mechanical Unit

15 It is highly preferable that the device of the present invention has a mechanical unit positioned upstream of the water treatment unit to facilitate water into the water treatment unit. It is preferred that the mechanical unit provides pressure to the water flowing into the treatment unit. A pressure of 80 psig or more is preferred of the water that enters into the treatment unit. It is more preferred that the mechanical unit is placed downstream of the water storage chamber. It is highly preferred that the mechanical unit is an
20 electromechanical unit such as a pump. When a pump is used, any type of pump used in the industry of water dispensing devices could be employed which serves the purpose of providing pressure to the water entering treatment unit.

Method

25 The present invention provides a method for providing output water in a constant TDS range by the device according to the first aspect, the method comprising,

- i. providing an inlet water flow through inlet into the water storage chamber;
- ii. allowing water to pass from the water storage chamber into the treatment unit;
- iii. sensing TDS of the water in the treated water line by the TDS sensor;
- iv. comparing the TDS sensed in step (iii) with the stored threshold TDS value; and

- v. draining water from the reject water line of the treatment unit through the drain line, when TDS value sensed is higher than the threshold TDS value, and alternately directing water from the reject water line of the treatment unit into the recycle line and into the water storage chamber when the sensed value of TDS is less than or equal to the threshold value of TDS to obtain the output water in a constant TDS range.

It is preferred that in the method of the present invention, threshold value of TDS ranges from 100 to 2000.

It is preferred that in the method of the present invention, the treatment unit is a reverse osmosis unit.

It is preferred that in the method of the present invention, the recycle line is provided with a flow restrictor downstream of the valve positioned at the multichannel connector or the recycle valve.

It is preferred that in the method of the present invention, water from the storage chamber is driven into the treatment unit via a mechanical unit.

It is preferred that in the method of the present invention, that the water from the storage chamber is driven into the treatment unit via a mechanical unit, preferably an electromechanical unit and most preferably a pump.

It is preferred that in the method of the present invention, that the method further comprises configuring the control circuit to store a threshold TDS value and compare the TDS sensed in step (iii) with the stored threshold TDS value and drain water from the reject water line of the treatment unit through the drain line, when TDS value sensed is higher than the threshold TDS value, and alternately when the sensed value of TDS is less than or equal to the threshold value of TDS, directs water from the reject water line of the treatment unit (4) into the recycle line (5A) and into the water storage chamber.

It is preferred that in the method of the present invention, that when the sensed value of TDS is less than or equal to the threshold value of TDS, directs water from the reject water line of the treatment unit (4) into the recycle line (5A) and into the water storage chamber, at that time, there is no water dispensed by the device and it is preferred that only when TDS value sensed is higher than the threshold TDS value and water is drained

from the reject water line of the treatment unit through the drain line, the water dispensing device of the present invention dispenses water.

Use

5 The present invention provides use of the device according to the device of the present invention for minimizing waste water

The present invention also provides use of the device according to the device of the present invention for maintaining TDS of output water from the device in a constant range.

10 The present invention provides a use of a control circuit configured to drain water from the reject water line of a treatment unit through the drain line, when TDS value sensed is higher than the threshold TDS value, and alternately when the sensed value of TDS is less than or equal to the threshold value of TDS, directs water from the reject water line of the treatment unit into the recycle line and into a water storage chamber,

in a water dispensing device comprising:

- 15
- a. a feed water inlet in fluid communication with a water storage chamber;
 - b. a water treatment unit positioned downstream of the water storage chamber, the treatment unit having a treated water line and a reject water line;
wherein, the reject water line is split by a multichannel connector into at least two lines, a recycle line and a drain line; wherein either a multi-
20 way valve is positioned at the multichannel connector or one valve corresponding for every split line, a drain line valve on the drain line and a recycle line valve on the recycle line downstream of the multichannel connector;
 - c. an electromechanical unit to facilitate the flow of water from the water
25 storage chamber into the treatment unit.
 - d. a TDS sensor positioned on the treated water line, adapted to measure TDS of the water flowing out of the treatment unit;
 - e. d. an outlet positioned downstream of the treated water line for dispensing water;

for minimizing waste water.

The present invention also provides a use of a control circuit configured to drain water from the reject water line of a treatment unit through the drain line, when TDS value sensed is higher than the threshold TDS value, and alternately when the sensed value
5 of TDS is less than or equal to the threshold value of TDS, directs water from the reject water line of the treatment unit into the recycle line and into a water storage chamber;

in a water dispensing device comprising:

- a. a feed water inlet in fluid communication with a water storage chamber;
- b. a water treatment unit positioned downstream of the water storage
10 chamber, the treatment unit having a treated water line and a reject water line;

wherein, the reject water line is split by a multichannel connector into at least two lines, a recycle line and a drain line; wherein either a multi-way valve is positioned at the multichannel connector or one valve corresponding for every split line, a drain line valve on the drain line and
15 a recycle line valve on the recycle line downstream of the multichannel connector;

- c. a TDS sensor positioned on the treated water line, adapted to measure TDS of the water flowing out of the treatment unit;
- d. an outlet positioned downstream of the treated water line for dispensing
20 water;

for maintaining TDS of output water from the device in a constant range.

It is preferred that the constant TDS range is between 30 to 250 ppm, more preferably
25 between 50 to 150 ppm and most preferably between 70 to 120 ppm.

The present invention provides use of a control circuit configured to drain water from a treatment unit through the drain line, when TDS value sensed is higher than the threshold TDS value, and alternately when the sensed value of TDS is less than or equal to the
30 threshold value of TDS, directs water from the reject water line of the treatment unit into the recycle line and into a water storage chamber; in a water dispensing device for maintaining TDS of output water from the device in a constant range.

It is preferred that the water dispensing device comprises:

- 5
- a. a feed water inlet in fluid communication with a water storage chamber (3);
 - b. a water treatment unit positioned downstream of the water storage chamber, the treatment unit having a treated water line and a reject water line;

10

wherein, the reject water line is split by a multichannel connector into at least two lines, a recycle line and a drain line; wherein either a multi-way valve is positioned at the multichannel connector or one valve corresponding for every split line, a drain line valve on the drain line and a recycle line valve on the recycle line downstream of the multichannel connector;

- c. a TDS sensor positioned on the treated water line, adapted to measure TDS of the water flowing out of the treatment unit; and
 - d. an outlet positioned downstream of the treated water line for dispensing water.
- 15

Figure 1 shows a water dispensing device (1) for providing output water in a constant Total Dissolved solids (TDS) range, the device (1) comprising:

- a. a feed water inlet (2) in fluid communication with a water storage chamber (3);
 - b. a water treatment unit (4) positioned downstream of the water storage chamber (3), the treatment unit (4) having a treated water line (6) and a reject water line (5);
- 20

25

wherein, the reject water line (5) is split by a multichannel connector (13) into at least two lines, a recycle line (5A) and a drain line (5B); wherein one valve corresponding for every split line, a drain line valve (9) on the drain line (5B) and a recycle line valve (10) on the recycle line (5A) is positioned downstream of the multichannel connector;

- c. a TDS sensor (7) positioned on the treated water line (6), adapted to measure TDS of the water flowing out of the treatment unit; and
 - d. an outlet (8) positioned downstream of the treated water line (6) for dispensing water.
- 30

A mechanical unit (12) is shown upstream of the treatment unit (4) for driving water into the treatment unit (4).

The water storage chamber (3) is adapted to receive water from the recycle line (5A).

Figure 1 also shows the recycle line (5A) is provided with a flow restrictor (11) downstream of the multichannel connector (13) on the recycle line (5A). Another flow restrictor (14) can also be seen on the drain line

Figure 2, on the other hand shows a version of the device of the present invention as shown in Figure 1 with a difference that a multi-way valve (13A) is positioned at the multichannel connector (13) instead of separate valves for corresponding drain line (5B) and recycle line (5A).

The present invention also provides a method for providing output water in a constant TDS range by the device according to the present invention, the method comprising steps of:

- i. providing an inlet water flow through inlet (2) into the water storage chamber (3);
- ii. allowing water to pass from the water storage chamber (3) into the treatment unit (4);
- 15 iii. sensing TDS of the water in the treated water line (6) by the TDS sensor (7);
- iv. comparing the TDS sensed in step (iii) with the stored threshold TDS value; and
- v. draining water from the reject water line (5) of the treatment unit (4) through the drain line (5B), when TDS value sensed is higher than the threshold TDS value, and alternately directing water from the reject water line (5) of the treatment unit (4) into the recycle line (5A) and into the water storage chamber (3) when the sensed value of TDS is less than or equal to the threshold value of TDS to obtain the output water in a constant TDS range.

In an exemplary case, the device of the present invention is provided and the control circuit of the device is configured to store a threshold TDS of 80ppm. When the device is in operation, the water will enter the feed water inlet supposing having a TDS of 1000 ppm and into the water storage chamber and then preferably pressurized preferably through a mechanical unit into the treatment unit. The treatment unit in turn will treat the water and the treated water will flow out of the treatment unit into the treated water line which has a TDS sensor positioned on it to sense the TDS of the treated water. The discard water from the treatment unit will flow out of the treatment unit via the reject water line. The reject water line is split into at least two lines, a recycle line and a drain line. There is provided either a multi-way valve or valves for each corresponding line emanating from the reject water line to ensure that preferably water flows through only

one split line at a time. At a given time, suppose the sensed TDS is 100 ppm, which is above the threshold TDS value of 80 ppm, then the water from the treatment unit will be drained through the drain line, and this process will continue until the TDS of the water sensed at the treated water line falls to less than the threshold value of 80 ppm. At
5 another time point, if the TDS sensor senses TDS of the treated water to be 75 ppm then preferably no water is allowed to drain and all the water from the reject water line is directed into the recycle line and finally into the water storage chamber. The choice of water flow path into the different lines can be preferably controlled by the control circuit by operably controlling the valves on the drain line and the recycle line, if the TDS of the
10 treated water is sensed to be higher than the threshold TDS value, then the water from the reject water line needs to be directed into the drain line and therefore, the recycle line is closed by operably controlling the recycle line valve and closing it or operably controlling the multi-way valve and stopping the flow of water into the recycle line. Similarly, when the TDS of the treated water is sensed to be lower than the threshold
15 TDS value, the water from the reject water line needs to be directed into the recycle line and therefore, the drain line is closed by operably controlling the drain line valve and closing it or operably controlling the multi-way valve and stopping the flow of water into the drain line.

The various features of the present invention referred to in individual sections above
20 apply, as appropriate, to other sections *mutatis mutandis*. Consequently, features specified in one section may be combined with features specified in other sections as appropriate. Any section headings are added for convenience only, and are not intended to limit the disclosure in any way.

The invention is not limited to the embodiments illustrated in the drawings. Accordingly,
25 it should be understood that where features mentioned in the claims are followed by reference numerals, such numerals are included solely for the purpose of enhancing the intelligibility of the claims and are in no way limiting to the scope of the claims.

Claims

1. A water dispensing device (1) for providing output water in a constant Total Dissolved solids (TDS) range, the device (1) comprising:
 - a. a feed water inlet (2) in fluid communication with a water storage chamber (3);
 - b. a reverse osmosis unit (4) positioned downstream of the water storage chamber (3), the treatment unit (4) having a treated water line (6) and a reject water line (5);

wherein, the reject water line (5) is split by a multichannel connector (13) into at least two lines, a recycle line (5A) and a drain line (5B); wherein either a multi-way valve (13A) is positioned at the multichannel connector (13) or one valve corresponding for every split line, a drain line valve (9) on the drain line (5B) and a recycle line valve (10) on the recycle line (5A) downstream of the multichannel connector (13);
 - c. a TDS sensor (7) positioned on the treated water line (6), adapted to measure TDS of the water flowing out of the treatment unit;
 - d. an outlet (8) positioned downstream of the treated water line (6) for dispensing water;
 - e. a control circuit configured to:
 - i. store a threshold TDS value; and
 - ii. drain water from the reject water line (5) of the treatment unit (4) through the drain line (5B), when TDS value sensed is higher than the threshold TDS value, and alternately when the sensed value of TDS is less than or equal to the threshold value of TDS, directs water from the reject water line (5) of the treatment unit (4) into the recycle line (5A) and into the water storage chamber (3);when the device is in operation.
2. A device according to claim 1, wherein threshold value of TDS ranges from 10 to 2000 ppm.
3. A device according to anyone of the preceding claims from 1 or 2, wherein the recycle line (5A) is provided with a flow restrictor (11) downstream of the multi-way valve (13A) positioned at the multichannel connector (13) or the recycle line valve (10).

4. A device according to anyone of the preceding claims from 1 to 3, wherein upstream of the treatment unit (4) is positioned a mechanical unit (12) for driving water into the treatment unit (4).
5. A device according to anyone of the preceding claims from 1 to 4, wherein the water storage chamber (3) is adapted to receive water from the recycle line (5A).
6. A method for providing output water in a constant TDS range by the device (1) according to claims 1 to 5 the method comprising,
 - i. providing an inlet water flow through inlet (2) into the water storage chamber (3);
 - ii. allowing water to pass from the water storage chamber (3) into the treatment unit (4);
 - iii. sensing TDS of the water in the treated water line (6) by the TDS sensor (7);
 - iv. comparing the TDS sensed in step (iii) with the stored threshold TDS value; and
 - v. draining water from the reject water line (5) of the treatment unit (4) through the drain line (5B), when TDS value sensed is higher than the threshold TDS value, and alternately directing water from reject water line (5) of the treatment unit (4) into the recycle line (5A) and into the water storage chamber (3) when the sensed value of TDS is less than or equal to the threshold value of TDS to obtain the output water in a constant TDS range.
7. A method according to claim 6, wherein water from the storage chamber (3) is driven into the treatment unit (4) via a mechanical unit (12).
8. A method according to claims 6 or 7, the method further comprises configuring the control circuit to store a threshold TDS value and compare the TDS sensed in step (iii) with the stored threshold TDS value and drain water from the reject water line (5) of the treatment unit (4) through the drain line (5B), when TDS value sensed is higher than the threshold TDS value, and alternately when the sensed value of TDS is less than or equal to the threshold value of TDS, directs water from the reject water line (5) of the treatment unit (4) into the recycle line (5A) and into the water storage chamber (3) when the device is in operation.
9. Use of the device according to claims 1 to 5 for minimizing waste water.

10. Use of the device according to claims 1 to 5 for maintaining TDS of output water from the device in a constant range.
11. Use as claimed in claim 10, wherein, the constant range of TDS ranges from 100 to 2000 ppm.
12. Use of a control circuit configured to drain water from reject water line (5) of a treatment unit (4) through the drain line (5B), when TDS value sensed is higher than the threshold TDS value, and alternately when the sensed value of TDS is less than or equal to the threshold value of TDS, directs water from reject water line (5) of the treatment unit (4) into the recycle line (5A) and into a water storage chamber (3) when the device is in operation;

in a water dispensing device comprising:

- a. a feed water inlet (2) in fluid communication with a water storage chamber (3);
- b. a reverse osmosis unit (4) positioned downstream of the water storage chamber (3), the treatment unit (4) having a treated water line (6) and a reject water line (5);
wherein, the reject water line (5) is split by a multichannel connector (13) into at least two lines, a recycle line (5A) and a drain line (5B); wherein either a multi-way valve (13A) is positioned at the multichannel connector (13) or one valve corresponding for every split line, a drain line valve (9) on the drain line and a recycle line valve (10) on the recycle line downstream of the multichannel connector (13);
- c. an electromechanical unit (6) to facilitate the flow of water from the water storage chamber (3) into the treatment unit (4).
- d. a TDS sensor (7) positioned on the treated water line (6), adapted to measure TDS of the water flowing out of the treatment unit (4);
- e. an outlet (8) positioned downstream of the treated water line (6) for dispensing water;

for minimizing waste water.

Fig. 1

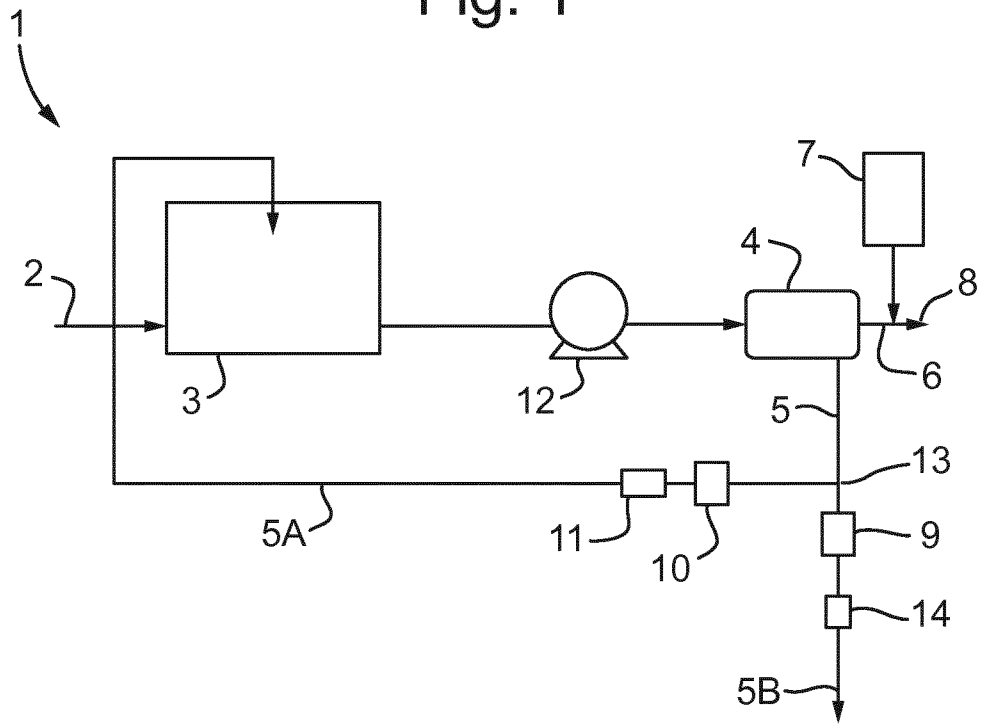
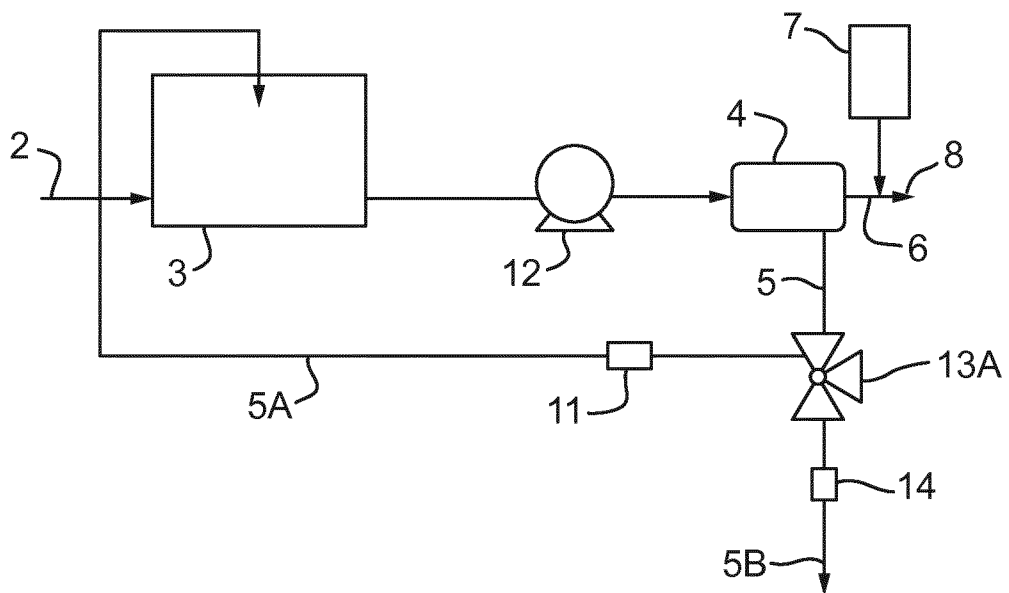

Fig. 2



INTERNATIONAL SEARCH REPORT

International application No
PCT/EP2018/080227

A. CLASSIFICATION OF SUBJECT MATTER INV. C02F1/44 B01D61/02 B01D61/12 ADD. C02F1/32 C02F1/28		
According to International Patent Classification (IPC) or to both national classification and IPC		
B. FIELDS SEARCHED Minimum documentation searched (classification system followed by classification symbols) C02F B01D		
Documentation searched other than minimum documentation to the extent that such documents are included in the fields searched		
Electronic data base consulted during the international search (name of data base and, where practicable, search terms used) EPO-Internal, WPI Data		
C. DOCUMENTS CONSIDERED TO BE RELEVANT		
Category*	Citation of document, with indication, where appropriate, of the relevant passages	Relevant to claim No.
X	EP 0 599 281 A2 (WAT WASSER UND UMWELTTECHNIK G [DE]) 1 June 1994 (1994-06-01) figures 1,2 page 2, lines 1-7,32-39 page 3, lines 31-54 page 4, lines 5-7,27-56 page 6, lines 2-40 page 7, line 45 - page 8, line 22 -----	1-12
X	CN 205 151 844 U (JIANGMEN TENGFEI TECH CO LTD) 13 April 2016 (2016-04-13) figure 1 paragraphs [0004] - [0007], [0009], [0015] - [0024] ----- -/--	1-12
<input checked="" type="checkbox"/> Further documents are listed in the continuation of Box C. <input checked="" type="checkbox"/> See patent family annex.		
* Special categories of cited documents :		
"A" document defining the general state of the art which is not considered to be of particular relevance "E" earlier application or patent but published on or after the international filing date "L" document which may throw doubts on priority claim(s) or which is cited to establish the publication date of another citation or other special reason (as specified) "O" document referring to an oral disclosure, use, exhibition or other means "P" document published prior to the international filing date but later than the priority date claimed	"T" later document published after the international filing date or priority date and not in conflict with the application but cited to understand the principle or theory underlying the invention "X" document of particular relevance; the claimed invention cannot be considered novel or cannot be considered to involve an inventive step when the document is taken alone "Y" document of particular relevance; the claimed invention cannot be considered to involve an inventive step when the document is combined with one or more other such documents, such combination being obvious to a person skilled in the art "&" document member of the same patent family	
Date of the actual completion of the international search <p align="center">28 November 2018</p>	Date of mailing of the international search report <p align="center">11/12/2018</p>	
Name and mailing address of the ISA/ European Patent Office, P.B. 5818 Patentlaan 2 NL - 2280 HV Rijswijk Tel. (+31-70) 340-2040, Fax: (+31-70) 340-3016	Authorized officer <p align="center">Rozanska, Agnieszka</p>	

INTERNATIONAL SEARCH REPORT

International application No
PCT/EP2018/080227

C(Continuation). DOCUMENTS CONSIDERED TO BE RELEVANT		
Category*	Citation of document, with indication, where appropriate, of the relevant passages	Relevant to claim No.
X	EP 0 394 777 A2 (KAERCHER GMBH & CO ALFRED [DE]) 31 October 1990 (1990-10-31) figure 1 column 1, lines 14-54 column 2, line 30 - column 4, line 15 -----	1-12
X	CN 102 583 808 A (CIXI FUHAI TOWN SIWEI IND PRODUCT DESIGN STUDIO) 18 July 2012 (2012-07-18) figure 1 abstract paragraphs [0003] - [0017] -----	1-12
X	CN 205 965 523 U (ZHEJIANG QINYUAN WATER PURIFIER SCIENCE & TECHNOLOGY CO LTD) 22 February 2017 (2017-02-22) paragraphs [0001], [0009] - [0042] -----	1-12
A	CN 104 291 414 B (ZHUHAI GREE ELEC APPLIANCES) 15 June 2016 (2016-06-15) the whole document -----	1-12
A	CN 105 621 535 A (SHANGHAI OZNER WATER PURIFICATION SCIENCE AND TECH DEV CO LTD) 1 June 2016 (2016-06-01) the whole document -----	1-12

INTERNATIONAL SEARCH REPORT

Information on patent family members

International application No PCT/EP2018/080227

Patent document cited in search report	Publication date	Publication date	Patent family member(s)	Publication date
EP 0599281	A2	01-06-1994	DE 4239867 A1 DE 4244978 B4 EP 0599281 A2	01-06-1994 26-04-2007 01-06-1994
CN 205151844	U	13-04-2016	NONE	
EP 0394777	A2	31-10-1990	DE 3913920 A1 EP 0394777 A2	31-10-1990 31-10-1990
CN 102583808	A	18-07-2012	NONE	
CN 205965523	U	22-02-2017	NONE	
CN 104291414	B	15-06-2016	NONE	
CN 105621535	A	01-06-2016	NONE	