

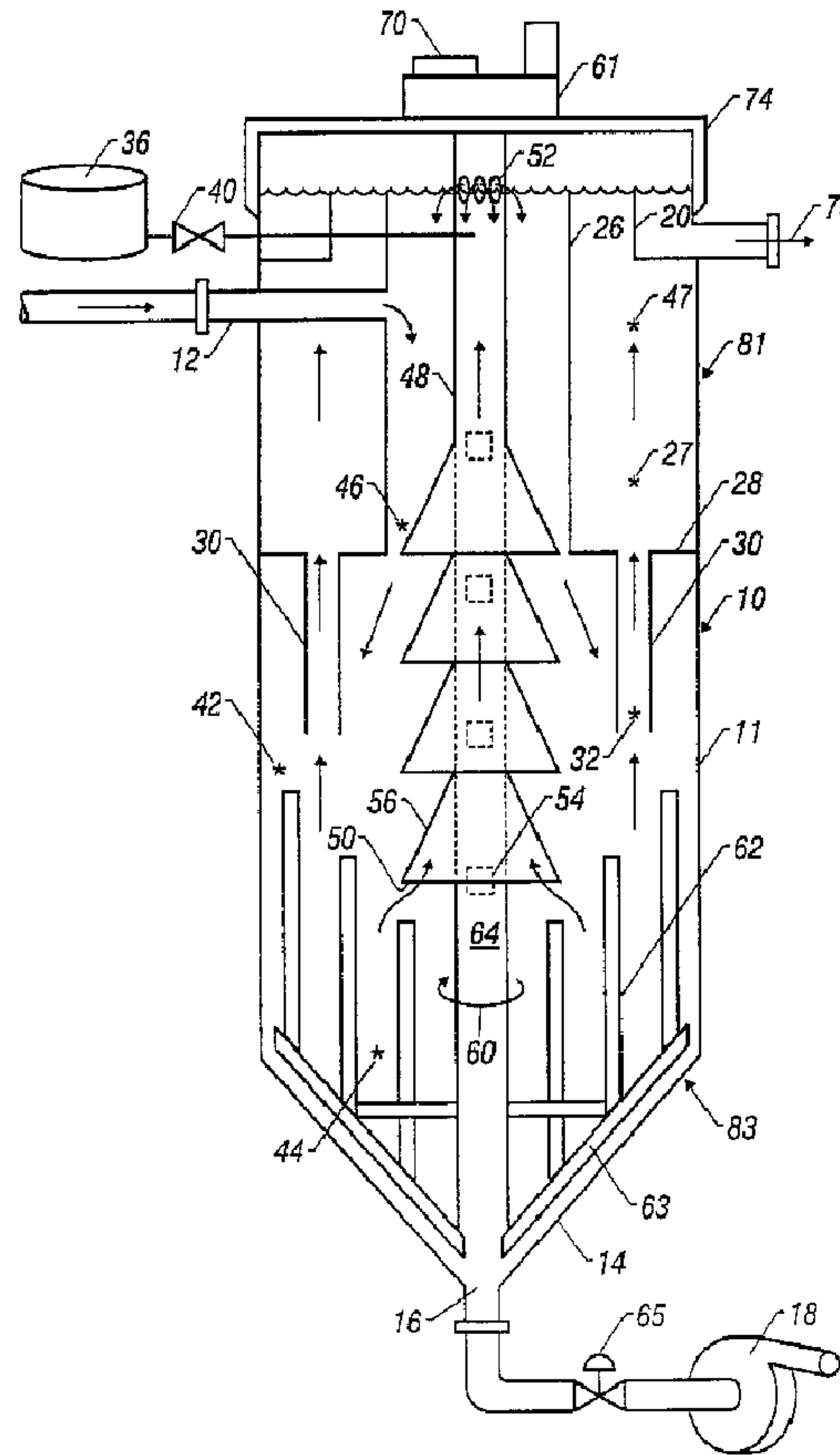

(86) Date de dépôt PCT/PCT Filing Date: 2000/07/26  
 (87) Date publication PCT/PCT Publication Date: 2001/02/15  
 (45) Date de délivrance/Issue Date: 2006/09/19  
 (85) Entrée phase nationale/National Entry: 2002/02/04  
 (86) N° demande PCT/PCT Application No.: US 2000/020334  
 (87) N° publication PCT/PCT Publication No.: 2001/010530  
 (30) Priorité/Priority: 1999/08/06 (US60/147,652)

(51) Cl.Int./Int.Cl. *B01D 21/00* (2006.01),  
*B01D 21/06* (2006.01), *B01D 21/08* (2006.01),  
*B01D 21/18* (2006.01), *B01D 21/24* (2006.01),  
*B01D 21/28* (2006.01)  
 (72) Inventeur/Inventor:  
 BEDELL, DANIEL, US  
 (73) Propriétaire/Owner:  
 GROUPE LAPERRIERE & VERREAUULT INC., CA  
 (74) Agent: GOWLING LAFLEUR HENDERSON LLP

(54) Titre : APPAREIL D'ÉPAISSISSEMENT/CLARIFICATION DU TYPE LIT ÉPAIS À ÉLIMINATION DES LIQUIDES AMÉLIORÉE  
 (54) Title: DEEP BED THICKENER/CLARIFIERS WITH ENHANCED LIQUID REMOVAL



(57) **Abrégé/Abstract:**

The enhanced deliquifying of the compacted bed of deep bed thickener/clarifier is disclosed. Such an apparatus comprises a vessel receiving a slurry of liquid and solid particles suspended in the liquid. The vessel defines a free settling zone, a hindered

(57) **Abrégé(suite)/Abstract(continued):**

settling zone intermediate, an upper clarification zone and a lower compaction zone. A deliquifying member is provided in the vessel extending up between at least two zones for facilitating the upward flow of free liquid from one of the lower zones and the settling of particulates. A rotating rake shaft with pickets are so designed to release the interstitial liquid trapped in a lower zone. The pickets provide pathways for liquid to release generally vertically. The released liquid travels upward to the deliquifying member and on into the clarification zone. The lower zone, freed of the interstitial water, further collapses becoming more concentrated or dense.

(12) INTERNATIONAL APPLICATION PUBLISHED UNDER THE PATENT COOPERATION TREATY (PCT)

(19) World Intellectual Property Organization  
International Bureau(43) International Publication Date  
15 February 2001 (15.02.2001)

PCT

(10) International Publication Number  
WO 01/10530 A1

- (51) International Patent Classification<sup>7</sup>: B01D 21/06, 21/08, 21/18, 21/24, 21/28
- (21) International Application Number: PCT/US00/20334
- (22) International Filing Date: 26 July 2000 (26.07.2000)
- (25) Filing Language: English
- (26) Publication Language: English
- (30) Priority Data:  
60/147,652 6 August 1999 (06.08.1999) US
- (71) Applicant (for all designated States except US): BAKER HUGHES INCORPORATED [US/US]; Suite 1200, 3900 Essex Lane, Houston, TX 77027 (US).
- (72) Inventor; and  
(75) Inventor/Applicant (for US only): BEDELL, Daniel [US/US]; 533 East Aspen Way, Centerville, UT 84014 (US).
- (74) Agents: POLACEK, Michael et al.; Baker Hughes Incorporated, Suite 1200, 3900 Essex Lane, Houston, TX 77027 (US).
- (81) Designated States (national): AE, AG, AL, AM, AT, AU, AZ, BA, BB, BG, BR, BY, BZ, CA, CH, CN, CR, CU, CZ, DE, DK, DM, DZ, EE, ES, FI, GB, GD, GE, GH, GM, HR, HU, ID, IL, IN, IS, JP, KE, KG, KP, KR, KZ, LC, LK, LR, LS, LT, LU, LV, MA, MD, MG, MK, MN, MW, MX, MZ, NO, NZ, PL, PT, RO, RU, SD, SE, SG, SI, SK, SL, TJ, TM, TR, TT, TZ, UA, UG, US, UZ, VN, YU, ZA, ZW.
- (84) Designated States (regional): ARIPO patent (GH, GM, KE, LS, MW, MZ, SD, SL, SZ, TZ, UG, ZW), Eurasian

[Continued on next page]

(54) Title: DEEP BED THICKENER/CLARIFIERS WITH ENHANCED LIQUID REMOVAL

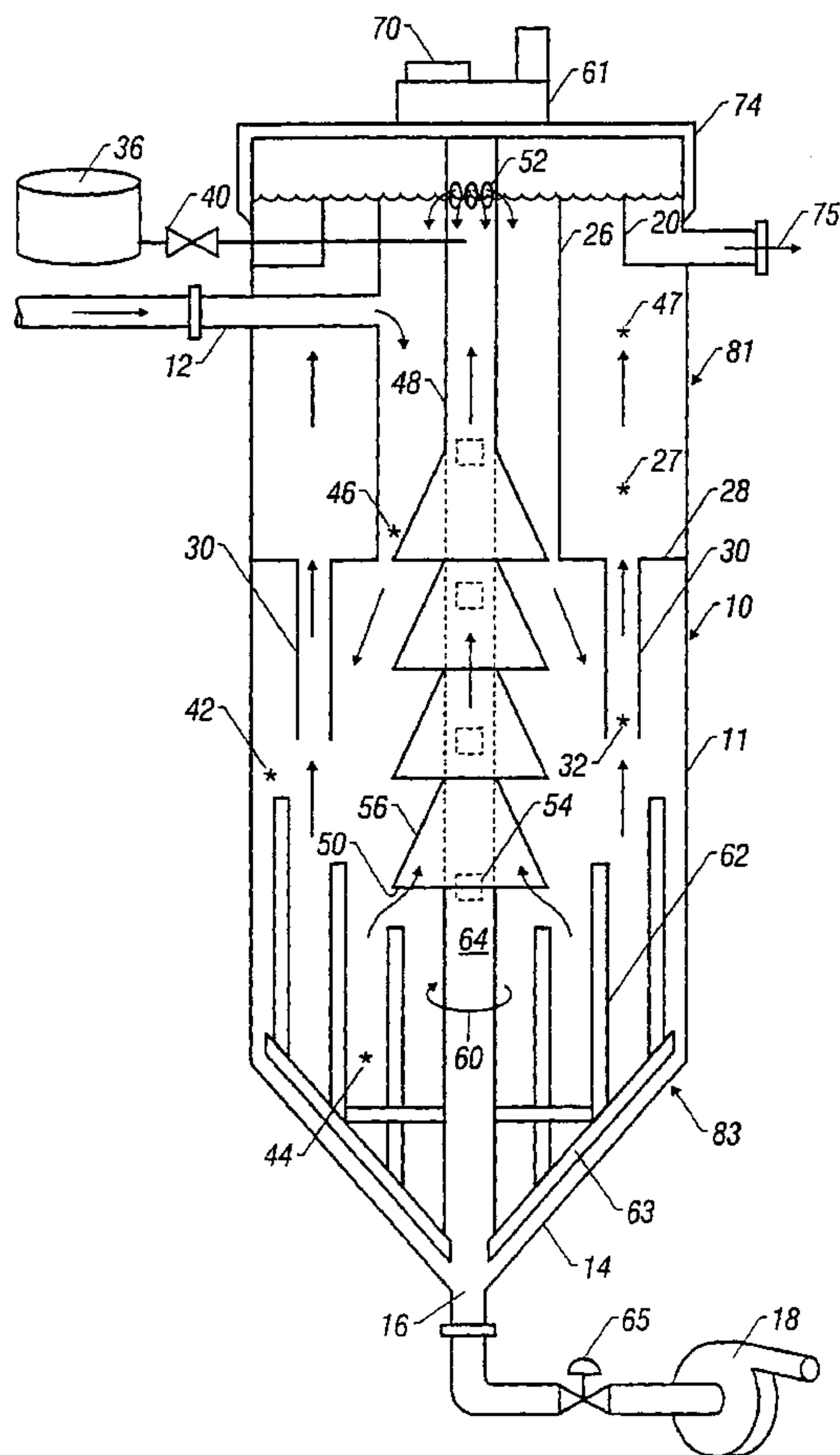

(57) Abstract: The enhanced deliquifying of the compacted bed of deep bed thickener/clarifier is disclosed. Such an apparatus comprises a vessel receiving a slurry of liquid and solid particles suspended in the liquid. The vessel defines a free settling zone, a hindered settling zone intermediate, an upper clarification zone and a lower compaction zone. A deliquifying member is provided in the vessel extending up between at least two zones for facilitating the upward flow of free liquid from one of the lower zones and the settling of particulates. A rotating rake shaft with pickets are so designed to release the interstitial liquid trapped in a lower zone. The pickets provide pathways for liquid to release generally vertically. The released liquid travels upward to the deliquifying member and on into the clarification zone. The lower zone, freed of the interstitial water, further collapses becoming more concentrated or dense.

WO 01/10530 A1

**WO 01/10530 A1**

patent (AM, AZ, BY, KG, KZ, MD, RU, TJ, TM), European patent (AT, BE, CH, CY, DE, DK, ES, FI, FR, GB, GR, IE, IT, LU, MC, NL, PT, SE), OAPI patent (BF, BJ, CF, CG, CI, CM, GA, GN, GW, ML, MR, NE, SN, TD, TG).

*For two-letter codes and other abbreviations, refer to the "Guidance Notes on Codes and Abbreviations" appearing at the beginning of each regular issue of the PCT Gazette.*

**Published:**

— *With international search report.*

**DEEP BED THICKENER/CLARIFIERS WITH ENHANCED  
LIQUID REMOVAL****BACKGROUND OF THE INVENTION**

This invention relates to clarifiers and thickeners of the deep bed type. This invention also relates to an associated method for separating liquid and solid particles in a suspension of slurry in thickness and clarifiers.

5           Deep bed thickeners and clarifiers (or so-called thickener/clarifier devices) are shown and described, for example, in U.S. Patent Nos. 5,433,862, 5,549,827 and 5,800,715.

10           The device described in U.S. Patent No. 5,433,862 comprises a vessel receiving a slurry of liquid and solid particles suspended on the liquid. The vessel defines a hindered settling zone in which the liquid and solids of the slurry tend to separate, with the solids settling down into a compaction zone below the hindered settling zone. In the compaction zone, the solids concentration tends to increase, while the liquid phase rises to a  
15           clarification zone above the hindered settling zone. An overflow launder, adjacent the upper end of the vessel, receives the overflow phase of the slurry separated in the vessel. An underflow discharge port toward the bottom of the vessel receives the thickened or underflow phase of the slurry separated in the vessel. One or more so-called separating members are  
20           provided in the vessel extending upwardly from a lower end in the hindered settling or compaction zones to an upper end in a clarification zone. Preferably, this member includes cones or other downwardly inclined surfaces that facilitate both the settling of solids down to the compaction zone and the upward flow of free liquid from the hindered settling and/or  
25           compaction zone to the clarification zone.

The deep bed thickener or clarifier device described in U.S. Patent No. 5,800,715 is similar to that disclosed in U.S. Patent No. 5,433,862, but further has a fluid flow barrier between the overflow clarification zone and the other zones of the vessel, and one or more clarifying conduits extending  
5 through the barrier. Each such conduit carries a suspended floc bed of particulate solids that filters and further clarifies the liquid flowing up from the hindered settling zone to the clarification zone. This further filtering removes solid particles that would otherwise be carried along the "clarified" liquid to the overflow launder. These clarification conduits thus serve a  
10 significantly different purpose than do the separating members and function independently thereof.

Deep bed thickener/clarifiers offer certain design and operational advantages over the conventional thickeners and clarifiers while providing clarity of overflow and solids concentration of underflow comparable to that  
15 of conventional thickener/clarifiers. Such thickeners and clarifiers are typically of low-profile design (i.e., shorter in height but of much greater diameter than deep bed thickeners), but like deep bed thickeners have generally central feedwells and underflow underflow discharge ports.

Conventional low profile thickeners rely on the radial expanse of the  
20 horizontal settling zones to effect settling of the slurry throughout the thickener. To achieve this settling action, the influent feed is typically dispersed radially outwardly from the central feedwell and rotating rake arms, having generally plow shaped blades, gather and laterally direct the settled solids along the thickener/clarifier bottom to the central discharge  
25 opening in the bottom of the thickener/clarifier tank. These rake blades are located closely adjacent the tank bottom and are designed to move the solids across the tank bottom with minimal disruption in the downward (or settling) flow pattern of the slurry through the hindered settling and

compaction zones. Consistent with this purpose, the rakes are rotated at a very slow speed, for example, less than 1 revolution per minute. U.S. Patent Nos. 4,082,671, 4,217,916 and 4,271,027, for example, describe and illustrate rake assemblies that perform this function of moving settled solids  
5 across the tank bottom of conventional low-profile thickeners for discharge at a central underflow outlet. Indeed, some of the rake assemblies are intended to scrape the settled solids from the tank bottom, see U.S. Patent No. 4,247,400.

In contrast, "deep bed" thickener/clarifiers rely on the height of the  
10 hindered settling to cause separation of the slurry into its clarified liquid and settled solids phases. Deep bed thickeners/clarifiers further have a deep, high angle conical bottom for directing the settled solids toward the discharge opening. Thus there is no need for rotating rakes to move the solids within the thickener/clarifier to effect removal of the solids. Indeed,  
15 rakes would serve little purpose in moving the solid, but rather would add expense and operating complexity.

Basically, deep bed thickeners rely on a conical tank bottom having a sidewall extending an angle from horizontal generally greater than the angle of repose of the settled solids to direct the solids to move by gravity  
20 alone along the tank bottom to the discharge opening. This eliminates the need for a rotating rake and thereby simplifies the operation and construction of the thickener/clarifier as well as reduces the cost of the thickener/clarifier compared to conventional thickeners/clarifiers. This cost reduction takes the form of the elimination of a capital expenditure for the  
25 rake assemblies, as well as the elimination of the associated torque driveheads and motors (often in excess of 1,000,000 foot pounds torque) and high strength bridges spanning the tank top to support the drive.

In contrast, conventional low profile thickener/clarifiers have tank bottoms that are flat or inclined at angles generally below the angle of repose of the settled solids and thus require rake assemblies and the associated drive and bridge (or column) structures to remove the settled  
5 solids from the thickener/clarifier.

### **SUMMARY OF THE INVENTION**

The present invention enhances liquid-solids separation in a deep bed thickener/clarifier and thus produces an underflow product or sludge which is thickened relative to that of existing deep bed thickeners/clarifiers.

10 More particularly, the deep bed thickener/clarifier of this invention provides for the release and removal of free or interstitial liquid (typically water) trapped in the settled solids in the hindered settling zone and/or the compaction zone. This release of liquid is effected without increasing the size of the thickener/clarifier, disturbing the settling processes or the  
15 naturally occurring movement of the solids along the conical tank bottom.

The deep bed thickener/clarifier of the present invention comprises a vessel with an overflow launder and an underflow discharge port. The vessel has an inlet for receiving a slurry of a liquid and solid particles suspended in the liquid. In an upper portion of the vessel, a free settling  
20 zone has a low concentration of solid slurry particles, while in a lower portion of the vessel, a compaction zone has a high concentration of solid slurry particles. The overflow launder is attached to the vessel adjacent an upper end thereof for discharge of an overflow phase of the slurry that has been separated in the vessel. The underflow discharge port is adjacent to a  
25 bottom thereof for discharge of a thickened, underflow phase of the slurry that has been separated in the vessel.

An upper portion of the vessel holds the free settling zone and a lower portion of the vessel holds the compaction zone. A hindered settling

zone extends between the free settling and compaction zones, with the hindered settling zone and compaction zone constituting lower settling zones. A deliquifying member is positioned in the vessel extending up from adjacent the lower portion of the vessel to adjacent the upper portion of the vessel for flow of liquid from at least one of the lower zones to the free settling zone. The deliquifying member further serves to isolate this flow of liquid from the flow of slurry down in the lower settling zones. A rake assembly is mounted for rotation in the lower portion of the vessel, with the rake assembly forming channels in the slurry held in the lower portion of the vessel for releasing liquid in at least one of said lower settling zones to flow to the deliquifying member and on to the free settling zone.

The method of this invention for operating a deep bed thickener/clarifier comprises, in accordance with the present invention, feeding, into a vessel, a slurry of a liquid and solid particles suspended in the liquid and separating the slurry by gravity into different zones having respective degrees of liquid-solids separation including, at an upper portion of the vessel, a free settling zone having a low concentration of solid slurry particles and further including, at a lower portion of the vessel, a compaction zone having a high concentration of solid slurry particles. A hindered settling zone is positioned between these zones. The method also comprises discharging, into an overflow launder attached to the vessel proximately to an upper end thereof, an overflow phase of the slurry that has been separated in the clarification zone and discharging, via an underflow discharge port fixed to the vessel at least proximately to a bottom thereof, a thickened, underflow phase of the slurry that has been separated in the vessel. Liquid is directed from at least one of the lower settling zones to the free settling zone via a flow path which is isolated from the flow of slurry down in the vessel in the lower settling zones. In accordance with this

invention, upwardly extending channels are formed in the slurry held in the lower portion of the vessel to release liquid in at least one of the lower settling zones to flow to the isolated flow path and then to the free settling zone.

5 Other objects of the invention will be in part apparent and in part described and shown in the following description of the drawings and preferred embodiments.

### **BRIEF DESCRIPTION OF THE DRAWINGS**

For detailed understanding of the present invention, reference should  
10 be made to the following detailed description of the preferred embodiments, taken in conjunction with the accompanying drawings, in which like elements have been given like numerals and wherein:

**FIG. 1** illustrates a vertical section of the thickener/clarifier of this invention and its various components including the deliquifying member  
15 and a rake assembly;

**FIG. 2** illustrates a vertical section of a second thickener/clarifier of this invention with the rake shaft passing through the inside of the deliquifying member; and

**FIG. 3** illustrates the enlarged detail of a rake picket in the slurry for  
20 forming a water flow channel in the slurry.

### **DESCRIPTION OF THE PREFERRED EMBODIMENTS**

As illustrated in **FIG. 1**, a deep bed thickener/clarifier of this invention, generally indicated at **10**, comprises a vessel **11** having an inlet  
**12** receiving a slurry comprising liquid and solid particles suspended in the  
25 liquid. The slurry components are separated in vessel **11** into a relatively light-weight overflow phase (i.e., a primarily clarified liquid) and a relatively heavy underflow phase (i.e., a primarily high solid concentration). Vessel **11** includes a downwardly tapering frusto-conical bottom **14** having

an apex (not designated) connected to an underflow discharge port **16** for the discharge of the thickened, underflow phase of the slurry that has been separated in vessel **11**. A variable speed pump and motor **18** communicate via a valve **65** with discharge port **16** for the controlled removal of the underflow from vessel **11**. Alternatively, a remotely actuated valve (not shown) may be provided as a mechanical end use device at discharge port **16** to control the removal of the underflow.

The thickener/clarifier **10** further includes an overflow weir or launder **20** for removal of the overflow phase separated from the slurry in vessel **11**. An upper lip (not designated) of launder **20** defines the upper level of the clarified liquid. A cylindrical wall **26** in vessel **11** forms an annular chamber **27** and defines a fluid barrier between the annular chamber and the remainder of the vessel interior. Projecting through a lower wall or panel **28** of annular chamber **27** is one or more elongate conduits **30** having generally vertically extending sidewalls which support fluidized floc beds **32** of the particulate material suspended in the different conduits, as described in greater detail in U.S. Patent No. 5,800,715. Two such conduits **30** are shown in **FIG. 1**. However, other vessel designs may have only one such conduit or more than two conduits. Conduits **30** are shown to be of square or circular shape in section, but may be of any shape in section.

To facilitate flocculation in vessel **11**, a settling agent such as a polyelectrolyte may be delivered as an additive to the slurry or as shown in **FIG. 1** preferably to the free settling liquid in the vessel. As shown in **FIG. 1**, a source of settling agent such as a storage tank **36** is in fluid flow communication with the vessel **11**. A fluid flow control device, such as a remotely actuated valve **40**, regulates the dosage of settling aid delivered to the slurry and thus control the extent of floc formation within vessel **11**.

The slurry received and held in vessel 11 separates by gravity into a hindered settling zone 42 which is located above a compaction zone 44 and below an interior free settling clarification zone 46 and an overflow clarification zone 47 in annular chamber 27. Within hindered settling zone 5 42, the liquid and solid particles tend to separate with the solid particles tending to flow downwardly to the compaction zone 44 and with the clarified liquid flowing up to clarification zone 47. Within compaction zone 44 the solids concentration increases to the highest level of concentration at discharge port or outlet 16 at the vessel bottom.

10 As described in U.S. Patent No. 5,433,862, a deliquifying member 48 extends up within vessel 11 from generally adjacent the compaction zone 44. Deliquifying member 48 is of generally tubular configuration and receives free liquid released from compaction zone 44 and delivers the liquid to the upper end of the deliquifying member 48 which is preferably 15 positioned at the interior free settling clarification zone 46. At its upper end, deliquifying member 48 is provided with openings 52 for feeding expressed liquid to the free settling clarification zone 46. In the thickener/clarifier of FIG. 1, the deliquifying member 48 also serves as part of a rotary drive member or rake shaft as described more fully hereinafter.

20 The vessel comprises an upper portion, indicated generally at 81, holding at least a portion of the free settling zone 46 and a lower portion, indicated generally at 83, holding at least a portion of the compaction zone 44. The hindered settling zone 42 may extend into either the upper or lower portion of the vessel. The compaction zone 44 and hindered settling zone 25 42 constitute lower settling zones. The deliquifying member 48 in the vessel extends up from the lower portion 83 of the vessel to the upper portion 81 of the vessel for flow of liquid from at least one of the lower settling zones to the free settling zone while isolating the flow of liquid from

the flow of slurry down into the lower settling zone. A rake assembly **63** is mounted for rotation as indicated at **60** in the lower portion **83** of the vessel and has a plurality of generally vertical pickets **62**. As shown in **FIG. 3**, as the rake assembly rotates, the pickets **62** travel through the slurry, see arrow **80**, and form temporary channels **76** in the slurry held in the lower portion of the vessel. These channels release free or interstitial liquid in pockets **75** in at least one of the lower settling zones to flow along generally vertical paths **72** to the deliquifying member **48**. From there, the liquid is free to flow on to the free settling zone **46**. The deliquifying member **48** supports and rotates the rake assembly **63**. At its upper end, deliquifying member **48** is operatively connected to a motor **70** via a drivehead **61**. The motor **70** may be of fixed or variable speed, and use any suitable motive power, such as an electric or hydraulic motor or a combustion engine.

Accordingly, the deliquifying member **48** facilitates removal of free liquid from at least one of the lower zones to enable solids in the compaction zone to increase to a higher concentration level and to do so more rapidly than would otherwise be possible. The deliquifying member **48** is open to hindered settling zone **42** to facilitate release of free liquid from that zone. To that end, deliquifying member **48** is provided with one or more suitable inclined members such as upwardly tapering conical deliquifying baffles **56** shown, for example, in **FIG. 1** as being ganged in a sequence. Each conical deliquifying baffle **56** is open at a lower end **50** and guides released liquid upwardly along an inner surface (not shown) to a respective opening or aperture **54** provided in deliquifying member **48**. Settling solids particles are directed along the outer surfaces of conical deliquifying baffles **56** towards the bottom of vessel **11**. Thus the deliquifying member **48** isolates the upward flow of liquid from the downward flow of the slurry.

Deliquifying member **48** provides a conduit for the flow of free liquid thus released from hindered settling zone **42** and compaction zone **44**. This channeling of the released liquid in those zones influences the solids settling rate therein. Deliquifying member **48** is shown to be a tube of  
5 circular or square cross-section. However, deliquifying member **48** may be of other shapes as described and shown in U.S. Patent No. 5,433,862. The word "tubular" is used herein to mean a hollow profile of any suitable cross-sectional shape.

In operation, deliquifying member **48** is rotated at a slow rate during  
10 the gravity settling process. The consequent movement of the pickets **62** through the thickened slurry or sludge in the lower zones releases otherwise trapped interstitial liquid **71**. This freed liquid **71** generally escapes from compaction zone **44** in laminar flow paths along pickets **62**, as illustrated in **FIG. 3**. The overall process of thickening or clarification in apparatus **10** is  
15 controlled by adjusting the underflow withdrawal and overflow discharge rates relative to the inlet. Thickener/clarifier **10** as provided with a rotatable rake assembly **63** provides for higher underflow solids concentration, improved overflow clarity, increased rate of influent feed, reduced settling aid usage or any combination of these advantages or results than would be  
20 possible in treating slurries in conventional deep bed or low-profile, large diameter thickener/clarifiers.

Thickener/clarifier **10** includes a cover plate or upper panel **74** which carries drivehead **61** and motor **70**. An outlet port **75** is provided at the upper end of vessel **11** for discharging the clarified liquid phase which spills  
25 over weir or launder **20**. The deliquifying member **48** is rotatably suspended from cover plate or upper panel **74**.

**FIG. 2** depicts a second embodiment of the thickener/clarifier **110** which includes certain modifications with respect to the apparatus of **FIG.**

1. Like structures in **FIGS. 1** and **2** are designated with the same reference numerals.

In **FIG. 2**, the deliquifying member **148**, unlike the deliquifying member **48** in **FIG. 1**, does not serve to rotate the rake assembly and may be rigidly fixed to cover or upper panel **74**. The deliquifying member **148** is also shown to terminate at an upper end of a lowermost conical deliquifying baffle **56**.

Thickener/clarifier **110** includes a rotatable rake **163** having a plurality of generally parallel vertically extending pickets **162**. Rake **163** serves to augment or accelerate the deliquifying of the lower zones. Rake **163** is rotated by a drive shaft **166** which is generally coaxially and longitudinally disposed in deliquifying member **148**. Drive shaft **166** is rotatably journaled in cover plate or upper panel **74** and is operatively connected to drivehead **61** and motor **70**.

The upper three conical deliquifying baffles **56** communicate with a lumen or interior (not designated) of fluid flow member **148** via openings or apertures **154** provided in tubular fluid flow member **148**. As discussed above, settling solids particles are directed along the outer surfaces of conical deliquifying baffles **56** towards the bottom of vessel **11**.

The embodiment of **FIG. 2** also differs from that of **FIG. 1** in not incorporating clarification tubes (such as tubes **30**) and in directing flocculant to the free settling zone at the exterior of the deliquifying member **148**.

Although the invention has been described in terms of its preferred embodiments, those skilled in the art will recognize that numerous modifications and changes may be made while remaining within the scope and spirit of the invention. For example, pickets **62** and **162** of rakes **63** and **163**, respectively, extend parallel to one another vertically through

compaction zone **44** and into hindered settling zone **42**. Pickets **62** and **162** may be alternatively inclined at an angle to the vertical. In addition, conical deliquifying baffles **56** may be greater or fewer in number than four. The conical deliquifying baffles located below chamber **27** may be larger. In  
5 addition, the pickets may be positioned and be of sufficient length to extend into both the compaction zone **44** and hindered settling zone **42**. The deliquifying member **48, 148** may be open only adjacent its lower end to receive liquid from one of the lower zones and adjacent its upper end to discharge liquid conveyed by the member. Alternatively, the member may  
10 be open at a plurality of locations as well as for a substantial portion of its length.

Accordingly, it is to be understood that the drawings and description herein be offered by way of example to facilitate comprehension of the invention and should not be construed to limit the scope thereof.

15

**WHAT IS CLAIMED IS:**

1. A thickener/clarifier, comprising:
  - (a) a vessel having an inlet for receiving a slurry of a liquid and solid particles suspended in the liquid, said vessel having an upper portion holding a free settling zone having a relatively low concentration of solid slurry particles and having a lower portion holding a compaction zone having a relatively high concentration of solid slurry particles and a hindered settling zone between said compaction zone and said free settling zone, with said compaction zone and said hindered settling zone constituting lower settling zones;
  - (b) an overflow launder adjacent said upper end of said vessel for discharge of an overflow phase of the slurry that has been separated in said vessel;
  - (c) an underflow discharge port adjacent said bottom of said vessel for discharge of a thickened, underflow phase of the slurry that has been separated in said vessel;
  - (d) a deliquifying member in said vessel extending up from said lower portion of said vessel to said upper portion of said vessel for flow of liquid from at least one of said lower settling zones to said free settling zone while isolating said flow of liquid from the flow of slurry down in said lower settling zones; and

- (e) a rake assembly mounted for rotation in said lower portion of said vessel, with said rake assembly having at least one elongated generally vertical picket forming channels in the slurry held in said lower portion of said vessel for releasing liquid in at least one of said lower settling zones to flow to said deliquifying member and on to said free settling zone.
- 5
2. The thickener/clarifier of claim 1 wherein said rake assembly further
- 10 includes a rotary drive for rotation of said rake assembly about a generally vertical axis.
3. The thickener/clarifier of claim 2 wherein said rotary drive is disposed at the upper end of said vessel, said rotary drive
- 15 being connected to said rake assembly via an elongate drive member extending vertically down into said vessel.
4. The thickener/clarifier of claim 3 wherein said drive member is of tubular configuration for at least a portion of its length to receive
- 20 liquid released from a lower settling zone.
5. The thickener/clarifier of claim 3 wherein said drive member is received in a tubular member surrounding said shaft, said tubular member receiving liquid released from a lower
- 25 settling zone.

6. The thickener/clarifier of claim 1 wherein said rake assembly includes a plurality of pickets extending generally parallel to one another.
7. The thickener/clarifier of claim 6 wherein said pickets extend  
5 into the compaction zone.
8. The thickener/clarifier of claim 7 wherein said pickets extend into both said compaction zone and said hindered settling zone.
9. The thickener/clarifier of claim 1 wherein said deliquifying  
10 member is open adjacent its lower end to receive liquid from at least one of said lower settling zones and is open adjacent its upper end to discharge liquid conveyed by said deliquifying member to said free settling zone.
10. The thickener/clarifier of claim 9 wherein said deliquifying  
15 member is open to receive liquid for a substantial portion of its length.
11. The thickener/clarifier of claim 9 wherein said deliquifying member is a tube with fluid flow openings therein.
12. The thickener/clarifier of claim 9 wherein said deliquifying  
20 member further comprises an inclined member extending over the opening in said deliquifying member adjacent its lower end.
13. The thickener/clarifier of claim 11 wherein said deliquifying  
25 member has openings at spaced locations along its length.
14. The thickener/clarifier of claim 13 wherein said deliquifying member has

inclined members extending over said openings in said deliquifying

member in said lower portion of said vessel.

- 5
15. The thickener/clarifier of claim 12 wherein said inclined member comprises a conical baffle.
- 10
16. The thickener/clarifier of claim 7 wherein said deliquifying member is open adjacent its lower end to receive liquid from at least one of said lower settling zones and said at least one of said picket extends below said opening adjacent a lower end of said deliquifying member.
- 15
17. The thickener/clarifier of claim 7 wherein said at least of said picket is positioned with its upper end below a lower end of said deliquifying member.
- 20
18. A method of operating a thickener/clarifier having an upper portion and a lower portion, comprising:
- 25
- (a) feeding a slurry of a liquid and solid particles suspended in the liquid into a vessel;
  - (b) separating said slurry by gravity into different zones having respective degrees of liquid-solids separation including, at a upper portion of said vessel, a free settling zone having a relatively low concentration of solid slurry particles and further including, at a lower portion of said vessel, a compaction zone having a relatively high concentration of solid slurry particles

- and a hindered settling zone between said free settling zone and said compaction zone, with said hindered zone and said compaction zone constituting lower settling zones;
- 5 (c) discharging an overflow phase of the slurry that has been separated in said vessel into an overflow launder adjacent to an upper end of said vessel;
- (d) discharging, via an underflow discharge adjacent a bottom of said vessel, a thickened, underflow phase of the slurry that has been separated in said vessel;
- 10 (e) directing liquid from at least one of said lower settling zones to flow up to said free settling zone via a flow path isolated from the flow of the slurry down in said vessel in said lower settling zones; and
- 15 (f) forming generally upwardly extending channels in the slurry held in said lower portion of said vessel to release liquid in at least one of said lower settling zones to flow to said isolated flow path and then on to said free settling zone.
- 20 19. The method of claim 18 further comprising moving a rake assembly in said lower portion of said vessel.
20. The method of claim 19 wherein said rake assembly is rotated about a generally vertical axis.
21. A thickener/clarifier, comprising:
- 25 (a) a vessel having an inlet for receiving a slurry of a liquid and solid particles suspended in the liquid, said vessel having an upper portion surrounding a free settling zone having a relatively low concentration of

solid slurry particles and having a lower portion surrounding a compaction zone having a relatively high concentration of solid slurry particles, and a hindered settling zone between said compaction zone and said free settling zone, with said compaction zone and said hindered settling zone constituting lower settling zones and having means for releasing liquid from at least one of said lower settling zones;

- (b) an overflow launder adjacent said upper end of said vessel for discharge of an overflow phase of the slurry that has been separated in said vessel;
- (c) an underflow discharge port adjacent said bottom of the vessel for discharge of a thickened, underflow phase of the slurry that has been separated in said vessel;
- (d) a deliquifying member in said vessel extending up from said lower portion of said vessel to said upper portion of said vessel for flow of liquid to said free settling zone from at least one of said lower settling zones while isolating said flow of liquid from the flow of slurry down in said lower settling zones; and
- (e) an injector for injecting flocculant into the flow of water to said free settling zone to facilitate settling of solid particles in the water.

22. The thickener/clarifier of claim 21 wherein the injector extends into said deliquifying member.

23. The thickener/clarifier of claim 21 wherein said deliquifying member includes an opening adjacent its upper end for discharge of liquid into said free settling zone and said

WO 01/10530

PCT/US00/20334

injector is positioned adjacent said opening in said deliquifying member.

1/3

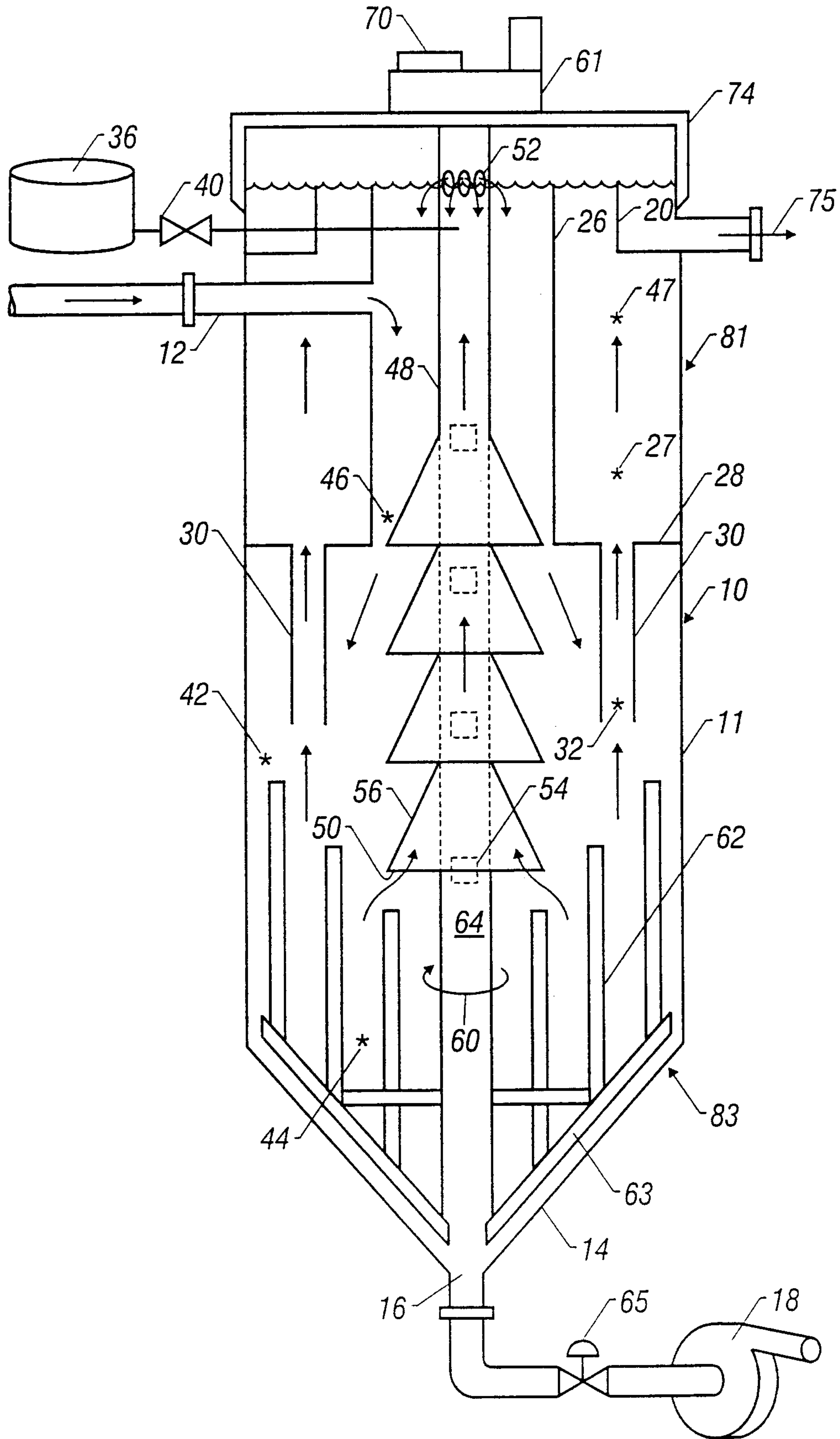

FIG. 1

2/3

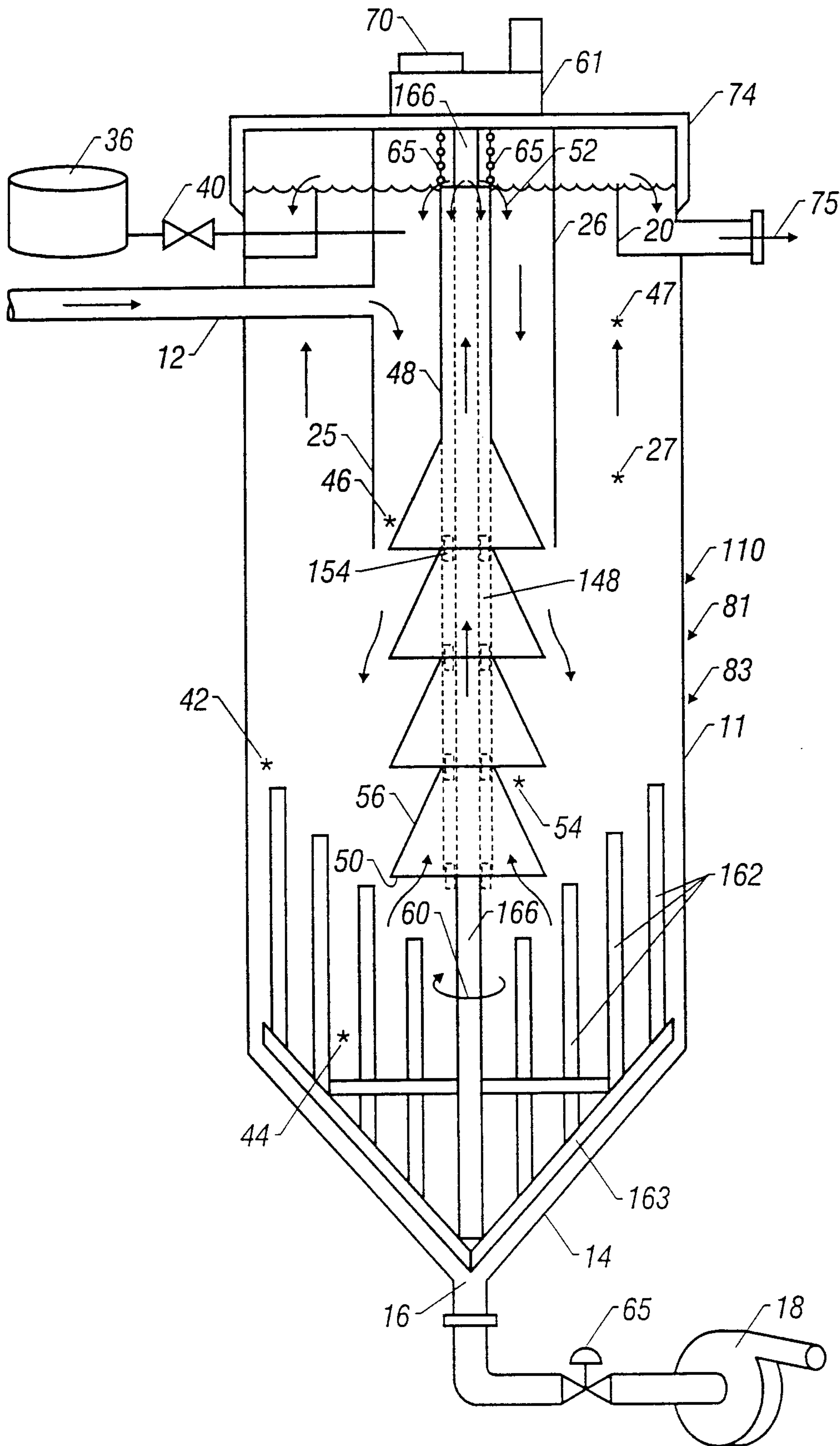

FIG. 2

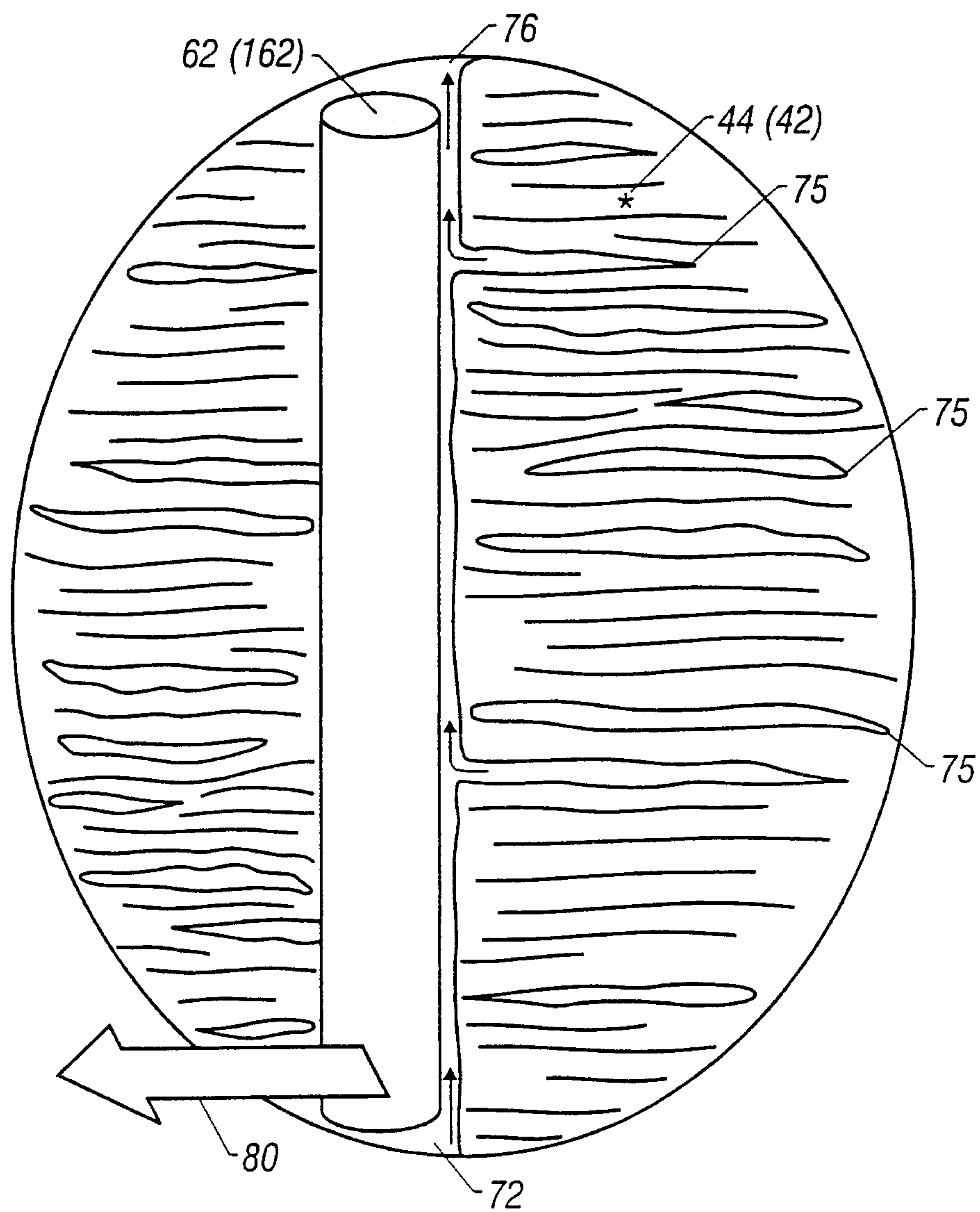

FIG. 3

