

19



Europäisches Patentamt
European Patent Office
Office européen des brevets

11 Publication number:

**0 355 703
A2**

12

EUROPEAN PATENT APPLICATION

21 Application number: 89115131.8

51 Int. Cl.4: **F24F 3/16**

22 Date of filing: 16.08.89

30 Priority: 19.08.88 JP 108836/88 U
30.12.88 JP 169555/88 U
30.12.88 JP 332426/88
13.02.89 JP 34431/89 U

71 Applicant: **SINRIN SEIKI SANGYO CO., LTD**
Chojahara Uruido Ichihara
Chiba 290-01(JP)

43 Date of publication of application:
28.02.90 Bulletin 90/09

72 Inventor: **Ishimoto, Shoichi**
40-4 Chibadera cho
Chiba shi Chiba ken(JP)

84 Designated Contracting States:
DE FR GB

74 Representative: **Walter, Helmut**
Aubingerstrasse 81
D-8000 München 60(DE)

54 **Method and apparatus for improving a life supporting environment with exhaled ingredients of living plants.**

57 Method and apparatus for improving a life supporting environment by utilizing the exhaled ingredients of living plants comprising closely cultivating plants within a given space, exposing the plants to light and adding a nutritious substance to the plants, heating the atmosphere in the given space to a temperature range of 25° C to 35° C to stimulate the physiological action of the plants so that the discharge of exhaled substances from the plants is increased, and furnishing the exhaled ingredients-containing air obtained to a human living space within a building.

EP 0 355 703 A2

Method and Apparatus for Improving a Life Supporting Environment with Exhaled Ingredients of Living Plants

BACKGROUND OF THE INVENTION

The present invention relates to a method and apparatus for improving a life supporting environment by utilizing exhaled ingredients of living plants and more particularly a method of improving a human life supporting environment and forming a life space which is good for the mind and body by introducing essence of trees, such as the exhaled ingredients of trees discharged from trees in a forest, to a space for human life activity within a building. Further the present invention relates to an apparatus for promoting the generation of volatile organic compounds of living plants and more particularly apparatus for improving an environment for human physiology and mental composure by cleaning the air in a building in which human life activity occurs and supplying air containing volatile organic compounds (what is called "phytoncide").

In a forest, the atmosphere is cleaned by interaction with living trees:

That is, it is known that injurious substances such as fine dust, No_x, So_x etc., in the air adhere to trees so that these injurious substances are removed from the air, while fresh air is supplied from trees and volatile organic compounds (phytoncide) such as the hydrocarbons of monoterpene, sesquiterpene, etc., or these hydrocarbons combined with hydroxyl or aldehyde groups, diterpene, phenolic compounds and so forth are discharged by trees. It is believed that these volatile organic compounds discharged by trees influence human physiological activity such as mental tranquility, mental composure, awareness, blood pressure, muscular strength, breathing, digestion in the stomach and intestine, urination, sterilization, insecticide, etc., and contribute to forming a better environment for human life.

However, lately, due to the cityward drift of population, the vegetation density of trees within the space where humans live is decreasing year after year and it is becoming difficult to revive the environment which has been destroyed by air pollution, therefore the life supporting environment is gradually worsening.

As a means for improving worsening air conditions in cities, heretofore, a filter is employed to remove floating matters in air within a room, or to remove the smells or the like through activated carbon. These means are effective in their way. However, in these cases, injurious matter is removed, but exhaled ingredients discharged from trees in the forest which act on human physiological activity are not supplied in the room.

Further, lately, perfume or essential oils extracted from trees are supplied through an air conditioning apparatus or the like into a room with a view to improving the indoor environment. However, in this case, only a part of the exhaled ingredients discharged from trees is supplied, which does not have the same effect as being immersed in a forest-bath and cannot be expected.

Further, potted plants are put in houses, office rooms, etc. However, this aims at improving the appearance of an environment, but cannot give the exhaled ingredients to a living space to the extent that exhaled ingredients of trees in a forest acting on human physiological activity can.

SUMMARY OF THE INVENTION

An object of the present invention is to provide a method for improving a life supporting environment in a building by utilizing the exhaled ingredients of living plants to a sufficient extent that the exhaled ingredients of trees can act on human physiological activity.

The object of the present invention is accomplished by a method for improving a life supporting environment by utilizing the exhaled ingredients of living plants comprised of closely growing plants in a given space. The plants are exposed to light and given a nutritious substance. The atmosphere in the given spaces heated to the temperature of from 25°C to 35°C to activate the physiological action of the plants so that the discharge of substances from the plants becomes more vigorous, and the exhaled ingredients-containing air is supplied to a human living space within a building.

According to the present invention, the physiological activity of trees can be activated so that the amount of exhaled ingredients is increased substantially. Therefore, within a small space, it is possible to clean the air to the same extent as in a large natural forest so that a cleaned atmosphere is provided to a human living space so as to initiate human physiological activity and provide mental composure to humans.

In a method according to the present invention, plants are grown in a space shut off from the outer atmosphere, and the air in the space where the plants are grown is supplied to the human living space by means of a blower with a view to increasing the efficiency of feeding exhaled ingredients to the human living space.

Further, in a method according to the present

invention, to increase the amount of exhaled ingredients of trees, new treetops are picked to increase the branches and leaves, or stimulation is given to branches and leaves of plants by applying an external force to the branches and leaves, or a dwarfing agent is given to the plants,

Another object of the present invention is provide apparatus for cleaning the air in a human living space within a building by supplying exhaled ingredients of plants to produce a living space which is good for the mind and body.

The object of the present invention is achieved by apparatus for cleaning air in a human living space within a building comprised of a container accomodating living plants, a pipe line passing through the container for conveying outside air into the living space and a blower for feeding outside air to the living space.

A further object of the present invention is to provide apparatus for promoting the generation of volatile organic compounds from living plants in which exhaled ingredients of living plants are supplied to a human living space to an extent that the exhaled ingredients effect human physiological activity.

This object is achieved with apparatus for promoting the generation of volatile organic compound from living plants comprised of a container accomodating an artificial forest, a jetting apparatus for jetting a fluid toward the artificial forest to stimulate the artificial forest.

In the present invention, stimulation of the artificial forest produces a large quantity of volatile organic compound.

Further, intermittently mechanical stimulation to trees, causes volatile organic compounds to be stored while when stimulation is not given to trees, stored volatile organic compounds and volatile organic compound generated generated by the stimulation are exhaled which results in an increase of the amount of exhaled ingredients of the trees generated.

According to the present invention, it is possible to generate a desired smaller amount of terpene volatile organic compounds from the artificial forest smaller in comparison to the living space to be cleaned. Since terpene volatile organic compounds produce the effect of a tonic, insectifuge, antibiotic, antiinflammatory, antitumor, hypotensive, insecticide, stimulant, a growth hormone, aromatic, laxative, sedative, anodyne, antipoison etc., the same effect as an immersion in forest-bath can be expected.

BRIEF DESCRIPTION OF THE DRAWINGS

Fig. 1 is a partial side view of one embodiment of the present invention wherein an equipment for growing plants is provided on the top of a roof,

Fig. 2 is a vertical section of another embodiment of the present invention wherein an equipment for growing plants is provided in an underground room,

Fig. 3 is a perspective view of a plant-growth apparatus for growing plants provided at the center of a hall,

Fig. 4 is a vertical section showing an example of an outer force applied to plants by jets of air,

Fig. 5 is a vertical section showing an example of an outer force applied to plants by cord-shaped affairs,

Figs. 6 (a) (b) shows an embodiment of the present invention as applied to an office,

Fig. 7 shows an embodiment of the present invention applied to a schoolroom,

Fig. 8 shows an embodiment of the present invention applied to a sickroom.

Fig. 9 shows an embodiment of the present invention applied to a home living room,

Fig. 10 shows an embodiment of the present invention applied to a window area and beneath a table in a conference room,

Fig. 11 shows an embodiment of the present invention applied to exective offices,

Figs. 12 (a) (b) show the essential features of an another embodiment of the present invention, (a) is a front view, and (b) is a top view, respectively,

Fig. 13 shows an embodiment of an air cleaning apparatus using living plants wherein a container having an artificial forest is provided on a rooftop,

Fig. 14 shows an embodiment of air cleaning apparatus using living plants wherein an artificial forest container is provided in an underground room,

Fig. 15 shows an embodiment of air cleaning apparatus using living plants provided with apparatus for promoting the generation of volatile organic compounds with air jets,

Fig. 16 shows an embodiment of air cleaning apparatus using living plants provided with an apparatus for promoting the generation of volatile organic compounds with both of air and water jets.

DETAILED DESCRIPTION OF EMBODIMENTS

The invention is now explained by examples with reference to drawings.

As shown in Figs. 1, 2 and 3, an arrangement for cultivating plants 1 according to the present invention comprises a bed 3 provided in a building

2. in which a planting bed 4 is constructed for plants 5, 6 such as trees.

The arrangement for cultivating plants 1 according to the present invention is positioned at any convenient place in building 1, for example on a roof, on the floor in the center of a hall or near the wall thereof, or on a terrace. Fig. 1 illustrates an example of an arrangement for cultivating plants provided on the roof of a dwelling, an office building etc. Fig. 2 shows an example of an arrangement for cultivating plants provided in an underground room, Fig.3 illustrates an example of an arrangement for cultivating plants provided on the floor in the center of a lobby or an entrance hall.

When utilizing natural lighting, it is preferable that the arrangement for cultivating plants be provided on a roof, in a bay window, or on a terrace etc. However, the arrangement for cultivating plants can be provided in a basement, a lobby, a hall or the like by introducing light into these places with the help of artificial lighting, or by a glass fiber or the like.

Further, the arrangement for cultivating plants 1 may be provided at an outside place adjacent to the building.

The planting bed 4 is not restricted to a specific one, but generally can be made of soil for garden plants, potted plants etc. The planting bed 4 may be of natural soil or be an artificial planting bed made of peatmoss, soft silica, formed plastics etc., or the plants may be cultivated by water culture.

In the present invention, a wide range of trees can be used for plants 5, for example trees which grow in a forest such as fir, hinoki, sugi, ginkgo, tree of life, eucalyptus, camphor or the like. Further vegetation such as pothos (*Scindapsus aureus*) or the like can be used for plants 5, if desired.

Particularly useful are trees which grow in temperates of the subarctic zone.

Plants 5, 5 are preferably young trees.

In the present invention, the term "young trees" means trees that are in most vigorous life activity, trees of from youthful to the prime of life fall under the category of "young trees". In general, annual plants to ten year trees, preferably three year trees to six year trees are used.

Plants 5, 5 of the same kind are used. However, it is desirable that the species of plants selected, or that plants of a different kind are used according to the purpose, since the phytoncide ingredients discharged from plants vary depending on the species of plants, hence physiological activities given therefrom vary.

Further, in the present invention, plants can be closely cultivated with a view to making spaces for growth of the plants as small as possible to increase the efficiency of space utilization. In the present invention, "being closely cultivated"

means that plants are grown closer than the growth density in a forest (for example at intervals of 15 cm), hence an artificially formed closely cultivated condition is desired.

Plants such as vegetating trees are cultivated at higher temperatures near the upper limit within the scope of a suitable temperature in which plants can live. Generally temperatures in the range of 25 to 35 °C are suitable. By cultivating plants at higher temperatures, physiological actions are stimulated so that exhaled ingredients are more plentifully discharged from the plants.

Any heating means such as an electric heater as shown in Fig. 1, a steam radiator gas or petroleum warm air heaters, radiative-type heaters or the like can be employed.

As occasion demands, an artificial illuminator 22 may be provided as shown in Fig. 2.

Further far infrared rays in the wave lengths between 2 μ and 7 μ , preferably between 3 μ and 6 μ , can be applied to the plants or to the planting bed by means of ceramics or the like while heating the plants or planting bed with the above heating means. Radiation in the of far infrared rays exterminate miscellaneous bacteria so that plants are preserved from a diseases as well as having the effect of changing the composition of exhaled ingredients.

In the present invention, plants are cultivated under conditions of extremely vigorous physiological actions. Therefore it is necessary that nourishment, such as manure, be fully provided and it is desirable that the application of the manure, temperature control and sprinkling of the water are automatically controlled.

Further picking new vegetation of the treetops makes leaf area larger and makes growth of branches and leaves increase. Thus by picking new vegetation of the treetops of plants, exhaled ingredients can be increased. Further by picking new vegetation of the treetops, the form of the trees can be regulated to present a visually attractive sight.

Exhaled ingredients are discharged from plants by cultivating the plants, and the air containing exhaled ingredients obtained is supplied to a human living space.

Because of this, it is possible to send air into the human living space by utilizing natural convection. However, in order to increase the effect, as shown in Figs. 1 and 2, it is preferable that space for vegetating plants 6 be closed off from outside 7, and if necessary, the atmosphere in the space for cultivating plants 6 can be distributed to human living space 10 through blower 6 and duct 9.

Further, a partition for forming the space for cultivating plants 6, is made of a transparent board such as glass, plastic or the like or created with an

air curtain.

When a transparent board is used, the board is coated with an anti-dimming or a resin such as a silicone resin, or teflon resin. An apparatus for injecting water to the board may be provided with a view to cleaning the surface of the board,

It is also preferable that air containing the exhaled ingredients be distributed to human living space 10 by means of blower 8 as shown in Fig. 2, while air in the human living space 10 is sent into the space for cultivating plants 6 through second duct 11 and second blower 12, thus air is circulated from human living space 10 to the space for cultivating plants 6.

Further, air outside building 2 can be brought in through third duct 13, and supplied to the human living space 10 through the space for cultivating plants 6.

Outside air supplied into the space for cultivated plants 6 is preferably supplied intermittently at lower temperature than the ambient temperature in the space for cultivating plants.

In this case, the outside air introduced is preferably supplied into the space for cultivating plants through filter 14 and activated carbon 15 to clean the air. Further the air introduced can be cleaned of NO_x, SO_x by passing both through an activated carbon living carbon body of cherry, platan, pseudo-acacia or ginkgo nuts.

Further, in the present invention, it is desirable that the plants are stimulated by an external force to induce the generation of exhaled ingredients. When the plants are wounded, physiological actions of the trees are activated so that the amount of exhaled ingredients occurring is increased.

A high speed air flow can be injected toward the plants to apply an external force to the plants. As shown in Fig. 4, a high speed air flow can be injected by means of intermittent blower 16 through fourth duct 17 and nozzles 18, 18.

Further, as shown in Fig. 5, flexible cord-shaped arrangements 19, 19 such as tape, rope, chain or the like are suspended from a carriage 20 run on rails 23 so that the cord-shaped arrangement 19, 19 are displaced and come into contact with the trees applying an external force on the trees. When the work for applying stimulation to trees is not in use, the carriage 20 may be positioned to one side so as not to spoil the beauty.

Further, by applying a dwarfing agent to trees, it is possible that the gnarl intervals are shortened without decreasing the number of leaves so that the height of the trees can be decreased.

Figs. 6(a) (b) show the present invention used in an office room,

Fig. 7 shows an embodiment of the present invention used in a schoolroom,

Fig. 8 shows an embodiment of the present

invention used in a sickroom,

Fig. 9 shows an embodiment of the present invention used in a home living room,

Fig. 10 shows an embodiment of the present invention used in a window and beneath a table in a conference room and

Fig. 11 shows an embodiment of the present invention used in an executive office room.

Fig. 12(a) (b) show the essential features of an another embodiment of the present invention, (a) is a front view, and (b) is a top view.

In the figures, an illumination lamp 30 is a source of light for supplementing natural light streaming through a transparent ceiling wall 29, a jet or spout of water 31 is provided to stimulate trees 28, a far infrared ceramic lamp 32 for heating the trees and is provided at four corners, a suction pipe 33 is for sucking volatile organic materials generated from the trees, pump 34 is a suction and discharge pump, inlet 35 is an outside air inlet 35 provided with a filter for protection from dust, tank 36 is a tank for culture solution, pipe 37 is for dripping sprinkling water, filter 38 is a filter layer, tank 39 is a tank for culture solution, pump 40 is an underwater pump, opening 41 is for water supply.

In the present invention, the physiological action of a plant is forced. Therefore there is an instance where a plant can become weak for a short space of time. When a plant has become weak, it is desirable that the weakened plant be transplanted to another place so that it can become vigorous.

Fig. 13 shows an embodiment for an air cleaning apparatus by living plants. According to the present invention wherein container 102 containing artificial forest 105' where trees 105 are closely planted is provided on the rooftop of a building, and air in the container 102 is distributed to several rooms 101'' by means of blower 103 through duct 104.

Fig. 14 shows an another embodiment of the present invention, wherein container 102 is provided in underground room 101' and air in the container 102 is distributed to several rooms 101'' by means of blower 103 through suction duct 104' and feeding duct 104''. Where the container is provided in underground room as shown in Fig. 14, light needed for growth of the plants is applied to trees with illuminating apparatus 105.

In these cases, the preferable amount of volatile organic compounds is determined related to the total volume of several rooms 101''. However, when the amount of volatile organic compound is great, the number of trees 105 in artificial forest 105'' in container 102 becomes large. In this case, there may be an instance when the number of trees 105 necessary not fit in container 102. In these cases, some means is needed that means must be

provided for increasing the amount of volatile organic compounds generated from each tree 105.

An example of the above means for increasing the amount of volatile organic compound is shown in Fig. 15. In the example, ceiling part of container 102 is provided with plural air jet nozzles 108, 108, etc, directed toward each tree 105. Air jet nozzles 108 are connected to intermittent blower apparatus 107 through duct 109.

Also, another example of means for increasing the amount of volatile organic compounds, is shown in Fig. 16. This example includes additional water jetting means besides the air jet means shown in Fig. 15. Water jet nozzles 112 are directed toward each tree at positions adjoined air jet nozzle 108. Water jet nozzle 112 are connected to an intermittent water supply apparatus 110 through feed pipe 111.

Then, the operation of the apparatus is as follows.

When outside air supplied to each room 101 through duct 104 passes through the branches and leaves of artificial forest 105 in container 102 by means of blower 103, as in case of the first example above, a strong wind is intermittently directed against each tree 105 from the air jet nozzles 108 of intermittent blower apparatus 107 or as in the second example above, both water and a strong wind are directed against each tree.

Thereby, branches and leaves of the foresaid compulsorily shake, and by the incitation, generation of volatile organic compounds from respective trees 105 is boosted by far above the amount produced by trees in their static state.

Claims

1. Method of improving a life supporting environment with the exhaled ingredients of living plants comprising, closely cultivating plants within a given space, exposing said plants to light and delivering a nutritious substance to said plants, as heating the atmosphere in said given space to the temperature of from 25°C to 35°C to stimulate physiological action of the plants so that discharge of exhaled substance from the plants is increased, and distributing the obtained exhaled ingredients-containing air to a human living space within a building.

2. Method for improving a life supporting environment by utilizing the exhaled ingredients of living plants as claimed in claim 1, wherein said plants are cultivated within said given space closed to the outer atmosphere, the atmosphere in said given space in which said plants are cultivated being supplied to said human living space by means of a blower.

3. Method for improving a life supporting environment by utilizing exhaled ingredients of living plants as claimed in claim 2, wherein the atmosphere in said given space in which said plants are cultivated is circulated from said given space where the plants are cultivated to the human living space.

4. Method for improving a life supporting environment by utilizing the exhaled ingredients of living plants as claimed in claim 2, wherein said given space where the plants are cultivated is closed to the outer atmosphere by a transparent plate such as a glass, plastic or the like.

5. Method for improving a life supporting environment by utilizing the exhaled ingredients of living plants as claimed in claim 2, wherein said given space where the plants are cultivated is closed to the outer atmosphere by an air curtain.

6. Method for improving a life supporting environment by utilizing the exhaled ingredients of living plants as claimed in claim 1, wherein new treetops are picked, forms of trees so that the branches and leaves are increased causing the amount of exhaled ingredients discharged from said plants are to be increased.

7. Method for improving a life supporting environment by utilizing the exhaled ingredients of living plants as claimed in claim 1, wherein the discharge of exhaled ingredients from said plants is enhanced by stimulating the branches and leaves of said plants by applying an external force to said branches and leaves.

8. Method for improving a life supporting environment by employing the exhaled ingredients of living plants as claimed in claim 7, wherein said stimulating is branches and leaves by applying a high speed air flow to said branches and leaves.

9. Method for improving a life supporting environment by utilizing the exhaled ingredients of living plants as claimed in claim 7, wherein said external force is applied to said branches and leaves by contacting said branches and leaves with many hung cord-shaped affairs.

10. Method for improving a life supporting environment by utilizing the exhaled ingredients of living plants as claimed in claim 1, including giving a dwarfing agent to said plants.

11. Method for improving a life supporting environment by utilizing the exhaled ingredients of living plants as claimed in claim 1, including supporting air cleaned through a filter made of activated carbon to said given space in which said plants are cultivated.

12. Method for improving a life supporting environment by utilizing the exhaled ingredients of living plants as claimed in claim 1, including cleaning the air supplied to said given space by passing it through activated carbon selected from the cherry,

platan, pseudo-acacia or ginkgo nut, is supplied to the space in which the plants are vegetated.

13. Method for improving a life supplying environment by utilizing the exhaled ingredients of living plants as claimed in claim 1, including introducing heated air to said given space in which said plants are cultivated. 5

14. Method for improving a life supporting environment by utilizing the exhaled ingredients of living plants as claimed in claim 1, including applying radiated heat to said plants or said planting bed to heat said plants. 10

15. Method for improving a life supporting environment by utilizing the exhaled ingredients of living plants as claimed in claim 1, including applying far infrared rays to said plants or said planting bed. 15

16. Apparatus for cleaning air in a human living space within a building comprising, a container providing a plurality of living plants, a pipe line passing through said container for conveying outside air to said human living space and a blower for feeding said outside air to said human living space through said container. 20

17. Apparatus for promoting the generation of a volatile organic compound living plants comprising a container providing artificial forest. a jetting means for jetting a fluid toward said artificial forest to give stimulated said artificial forest. 25

18. Apparatus for promoting the generation of a volatile organic compound from living plants as claimed in claim 17, wherein said jetting means is an air jetting device. 30

19. Apparatus for promoting the generation of a volatile organic compound of living plants as claimed in claim 17, wherein said jetting means is an air and water jetting device in which said air jetting device is combined with said water jetting device. 35

20. Apparatus for promoting the generation of a volatile organic compound of living plants as claimed in claim 17, said air and water intermittently jet said air and water. 40

21. Apparatus for promoting the generation of a volatile organic compound of living plants as claimed in claim 18, said air and water intermittently jet said air and water. 45

22. Apparatus for promoting the generation of a volatile organic compound of living plants as claimed in claim 19, said air and water intermittently jet said air and water. 50

55

7

FIG. 1

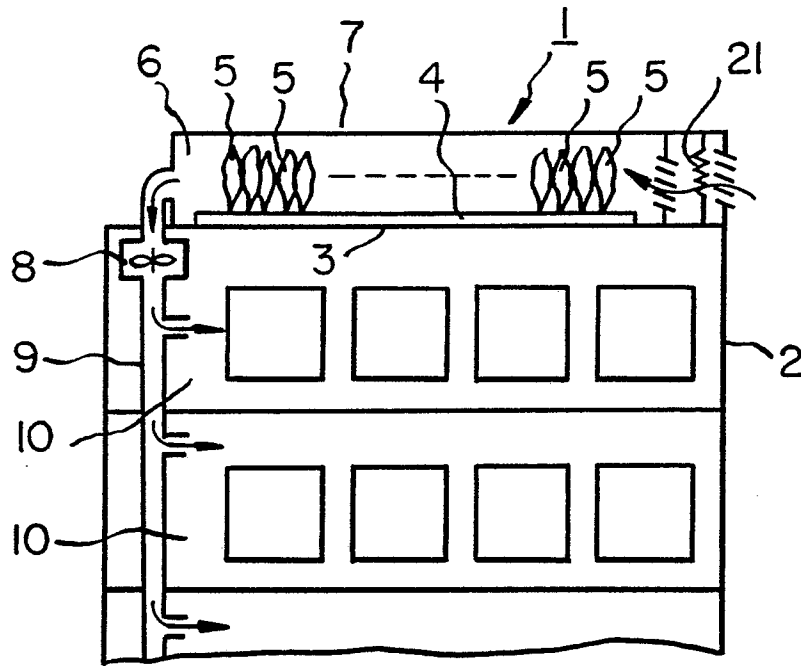

FIG. 3

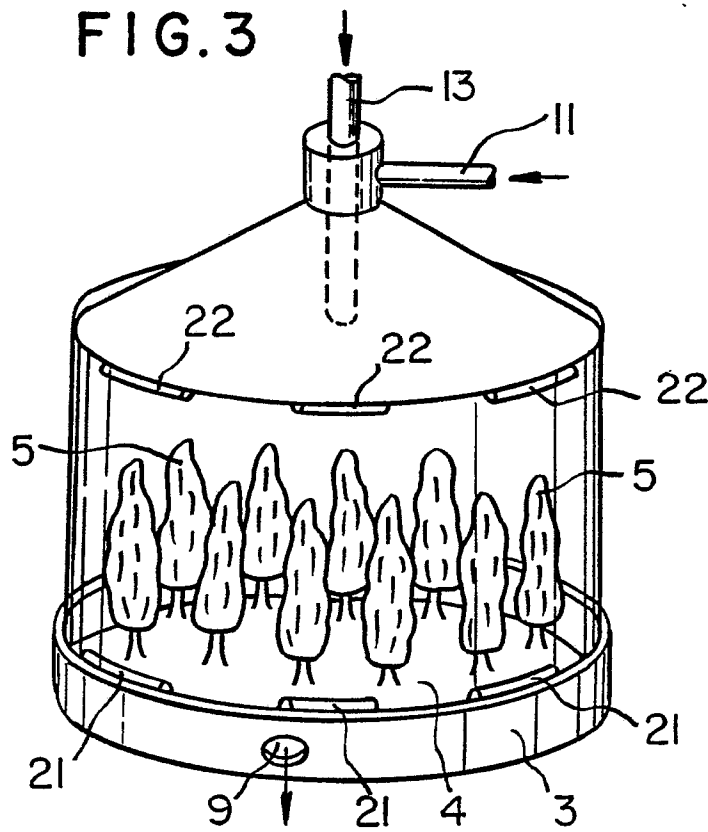

FIG. 2

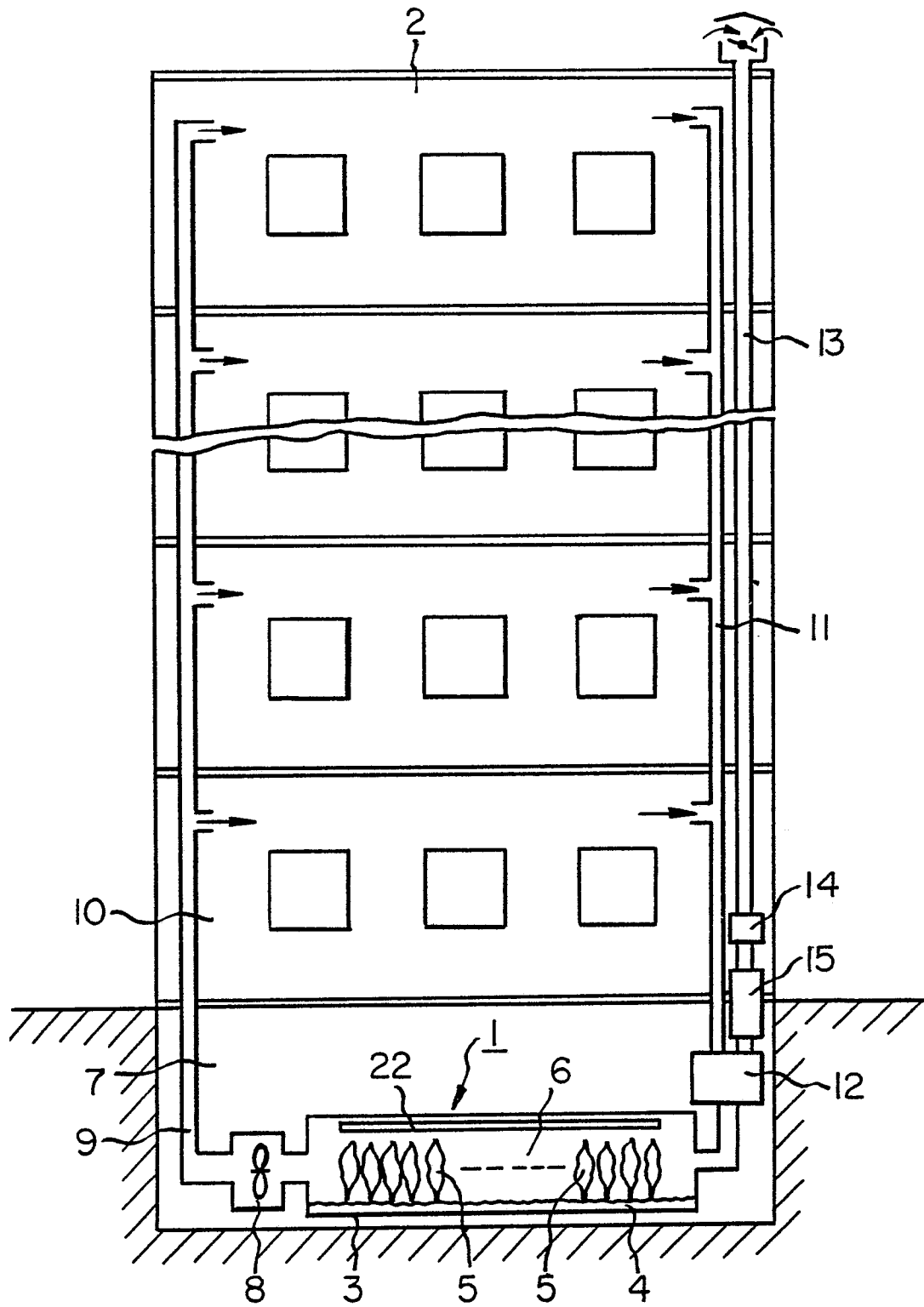

FIG. 4

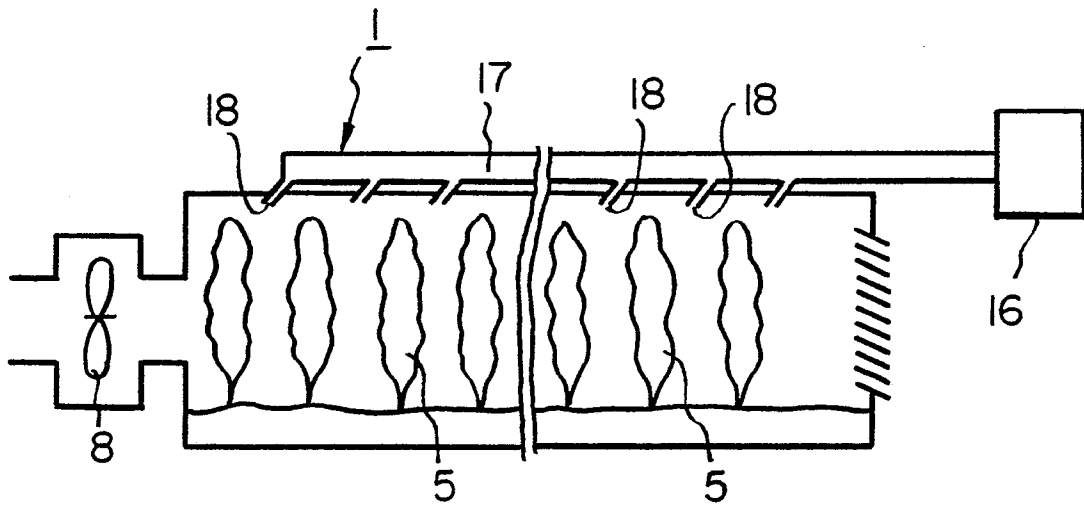

FIG. 5

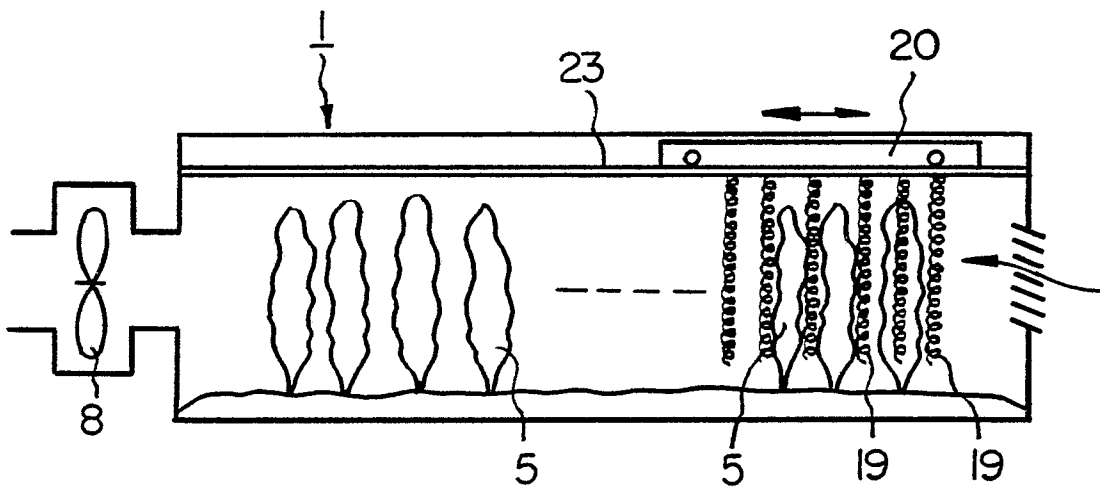

FIG. 6(a)

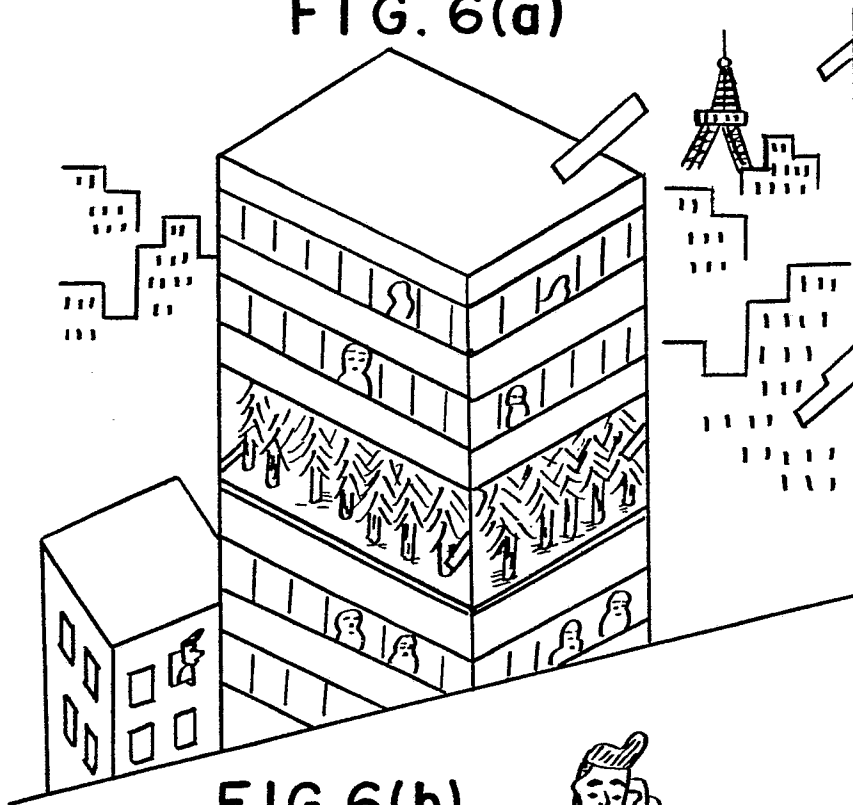

FIG. 6(b)

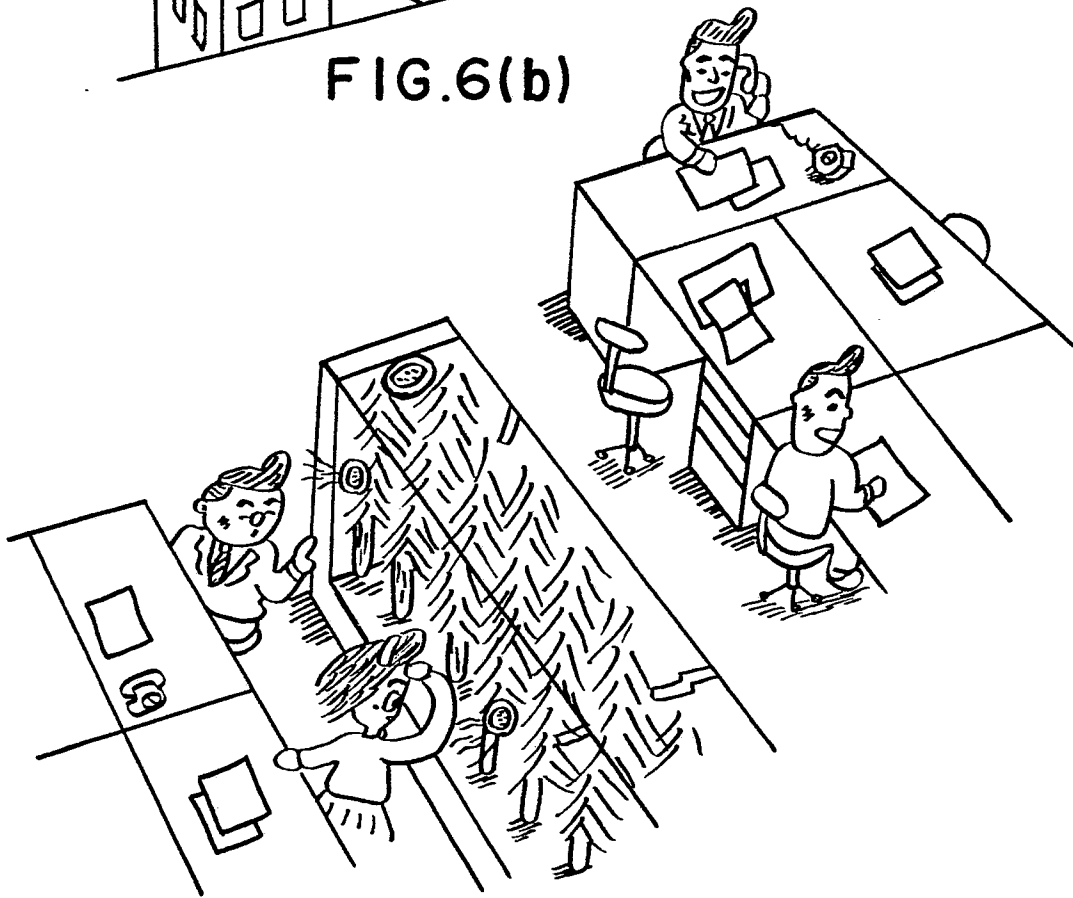

FIG. 7

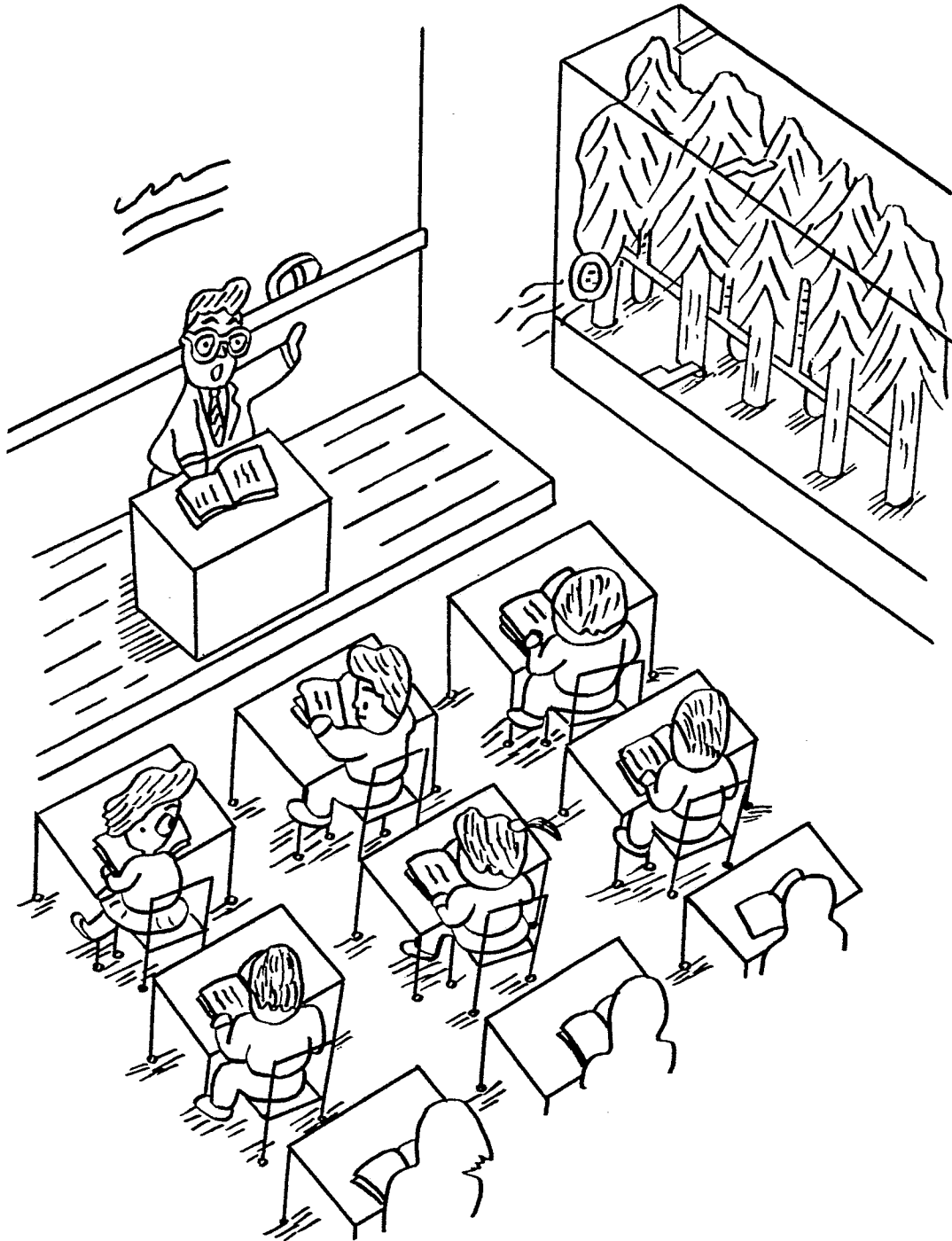

FIG. 8

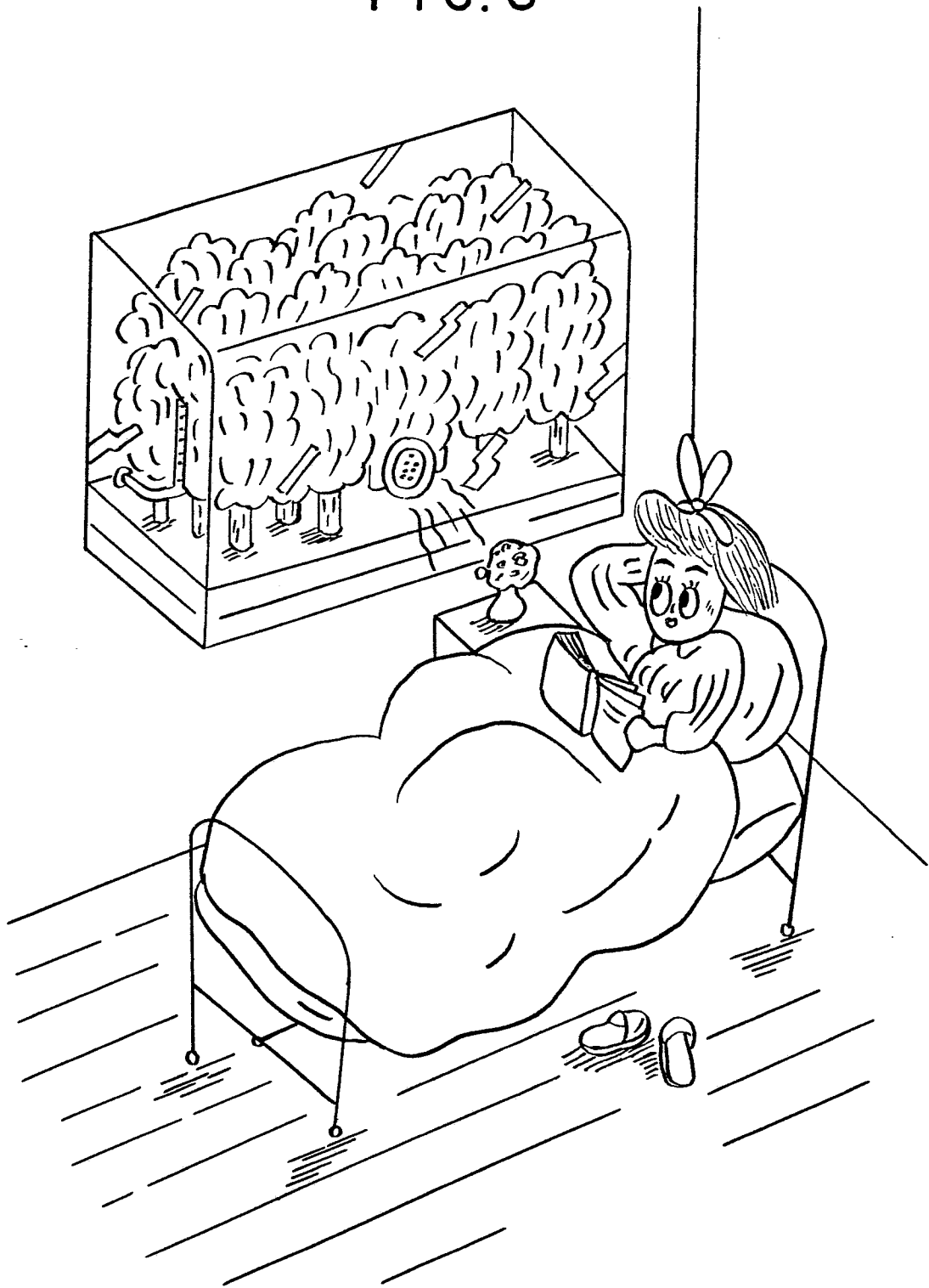

FIG. 9



FIG. 10

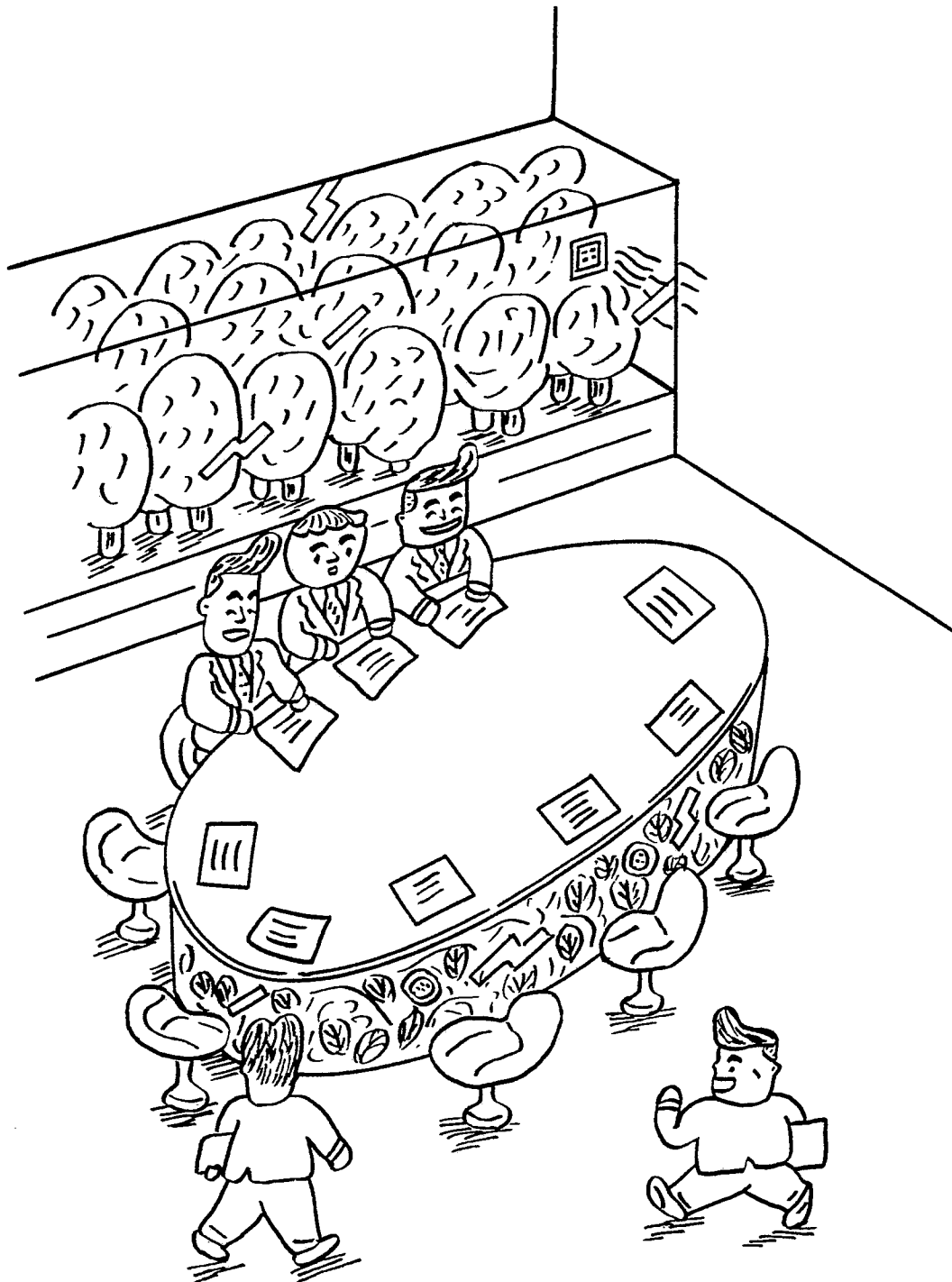

FIG. II



FIG. 12(a)

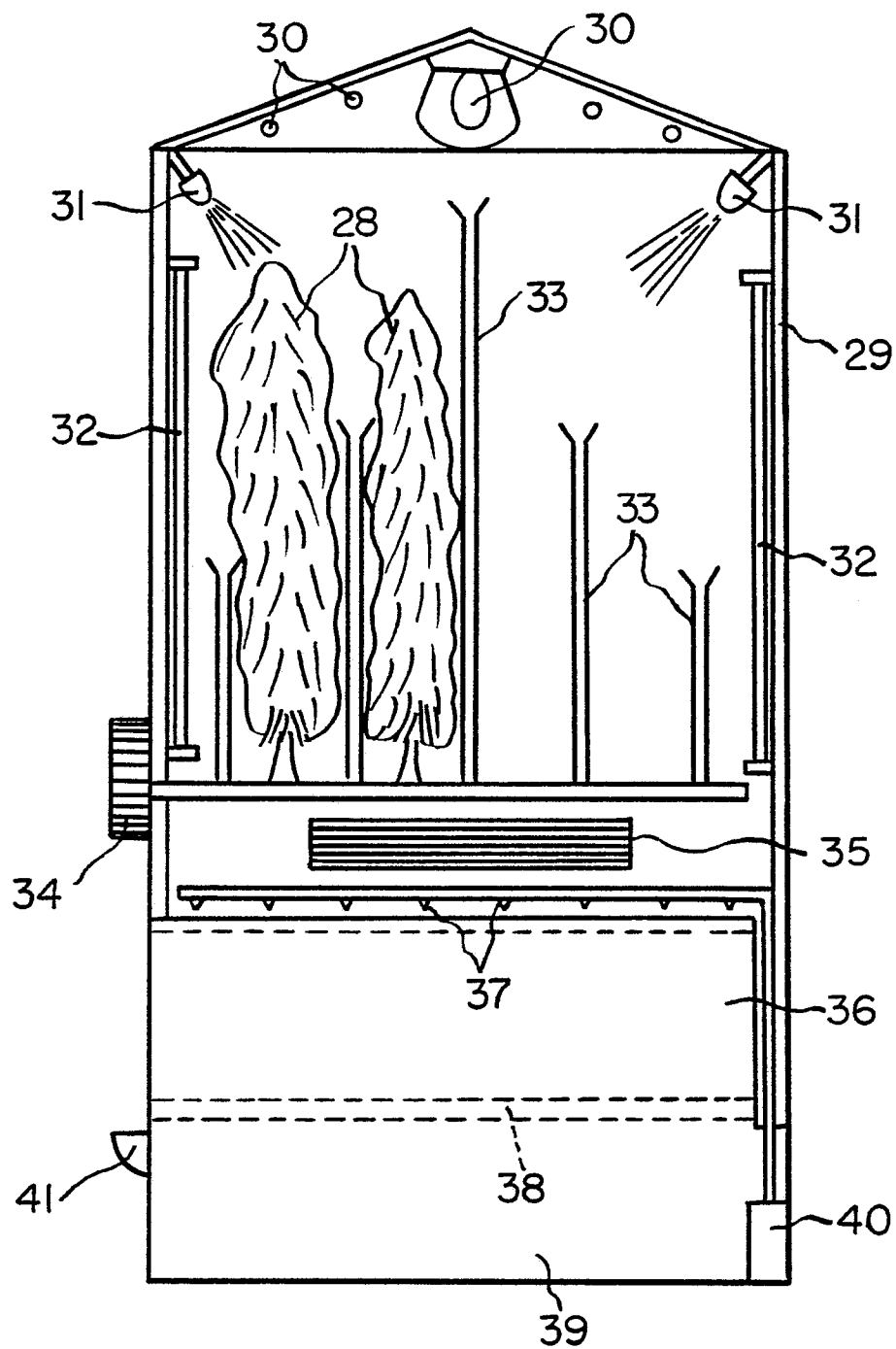

FIG. 12(b)

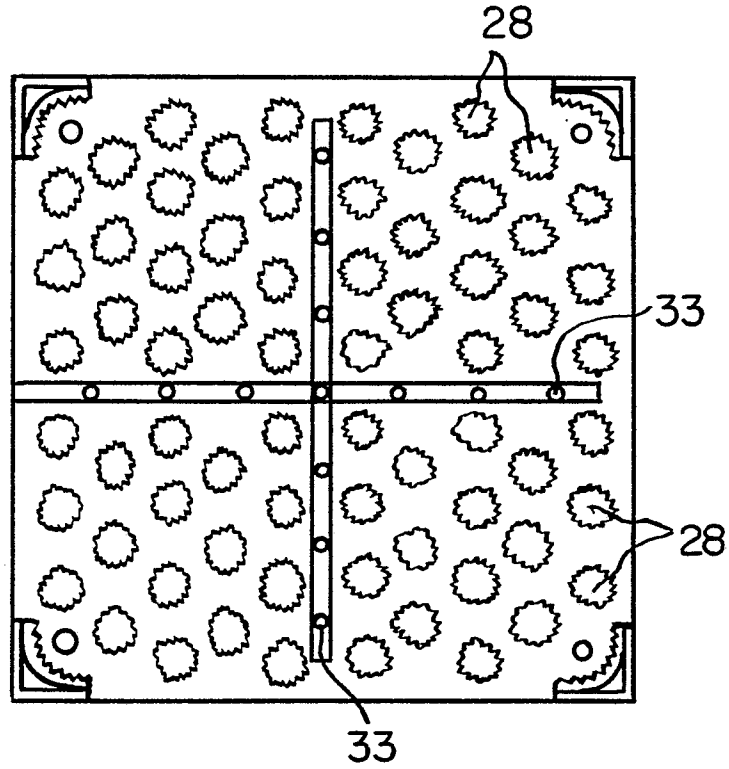

FIG. 13

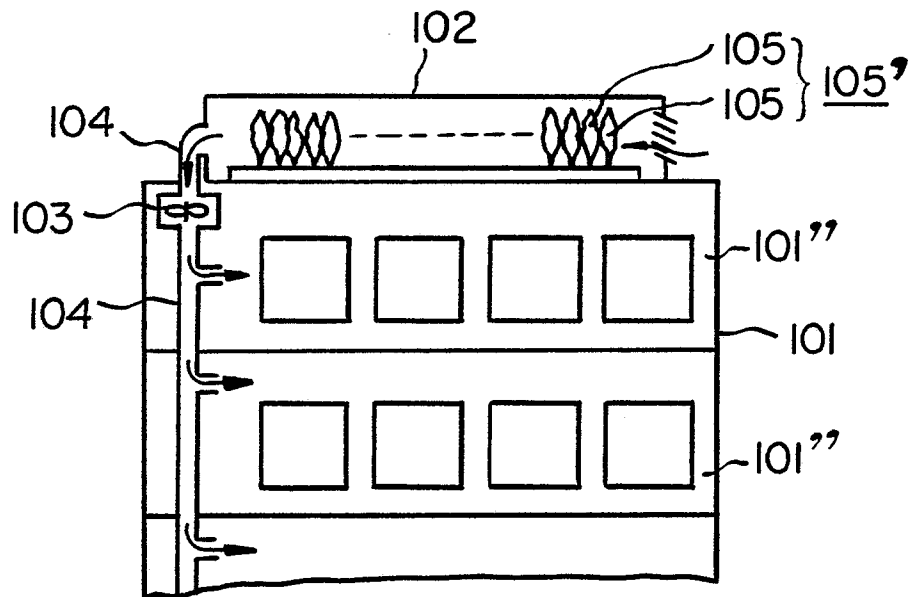

FIG. 14

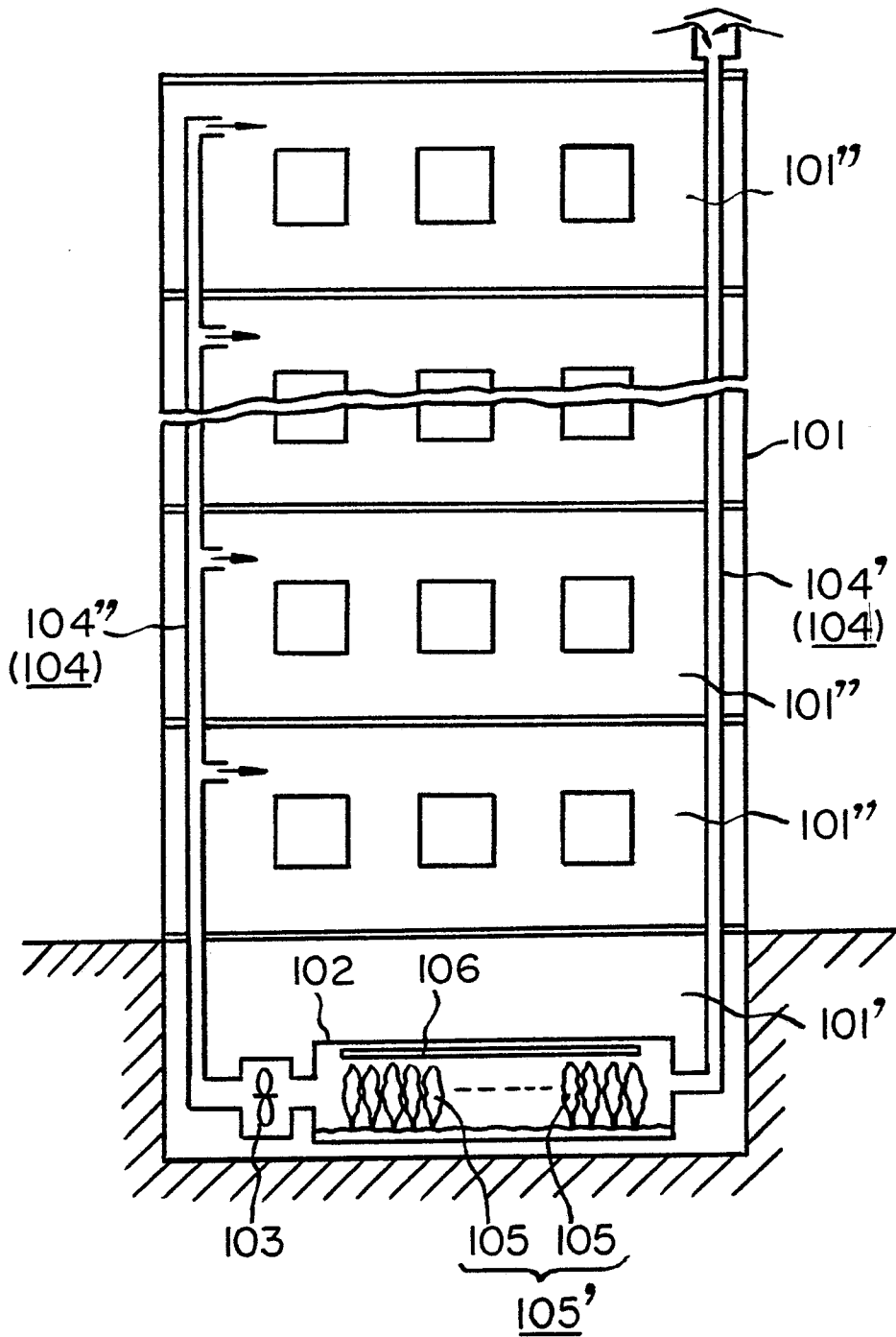

FIG. 15

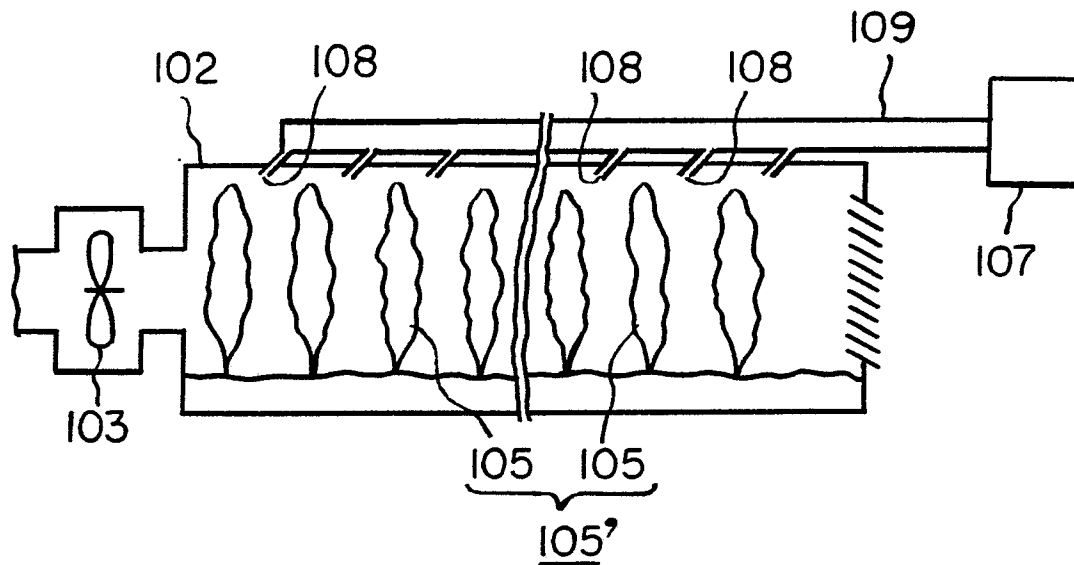

FIG. 16

