

(19) World Intellectual Property Organization
International Bureau



(43) International Publication Date
23 December 2009 (23.12.2009)

PCT

(10) International Publication Number
WO 2009/154501 A1

- (51) **International Patent Classification:**
H02J 7/00 (2006.01) *H01F 38/00* (2006.01)
E21B 47/12 (2006.01)
- (21) **International Application Number:**
PCT/RU2008/000388
- (22) **International Filing Date:**
19 June 2008 (19.06.2008)
- (25) **Filing Language:** English
- (26) **Publication Language:** English
- (71) **Applicant (for CA only):** **SCHLUMBERGER CANADA LIMITED** [CA/CA]; Eau Claire Place 1, 525 - 3rd Avenue S.W., 7th Floor, Calgary, Alberta T2P 0G4 (CA).
- (71) **Applicant (for FR only):** **SERVICES PETROLIERS SCHLUMBERGER** [FR/FR]; 42, rue saint Dominique, F-75007 Paris (FR).
- (71) **Applicant (for GB, JP, NL only):** **SCHLUMBERGER HOLDINGS LIMITED** [GB/GB]; P.O. Box 71, Craig-mur Chambers, Road Town, Tortola (VG).
- (71) **Applicant (for AL, AU, AZ, BG, CO, CZ, DE, DK, GQ, GR, HU, ID, IE, IL, IT, KR, KZ, LT, MX, MY, NO, NZ, OM, PL, RO, RU, SK, TD, TM, TN, TR, TT, UZ, ZA only):** **SCHLUMBERGER TECHNOLOGY B.V.** [NL/NL]; Parkstraat 83-89, NL-2514 JG The Hague (NL).
- (71) **Applicant (for all designated States except AL, AU, AZ, BG, CA, CO, CZ, DE, DK, FR, GB, GQ, HU, ID, IE, IL, IT, JP, KR, KZ, LT, MX, MY, NL, NO, NZ, OM, PL, RO, RU, SI, SK, TD, TM, TN, TR, TT, US, UZ, ZA):** **PRAD RESEARCH AND DEVELOPMENT N.V.** [NL/NL]; De Ruyterkade 62, Willemstad, Curacao (AN).
- (72) **Inventors; and**
- (75) **Inventors/Applicants (for US only):** **IAKIMOV, Mikhail Nikolaevich** [RU/RU]; Izumrudny, 10-5, Berdsk, Novosibirskaya obl., 633011 (RU). **ULYANOV, Vladimir Nikolaevich** [RU/RU]; ul. Vakh tangova, 39-79, Novosibirsk, 630058 (RU).
- (74) **Agent:** **PROKOFIEVA, Zhanna Sergeevna**; LLC "Technology Company Schlumberger", per. Ogorodnaya Sloboda, 5a, Moscow, 101000 (RU).
- (81) **Designated States (unless otherwise indicated, for every kind of national protection available):** AE, AG, AL, AM, AO, AT, AU, AZ, BA, BB, BG, BH, BR, BW, BY, BZ, CA, CH, CN, CO, CR, CU, CZ, DE, DK, DM, DO, DZ, EC, EE, EG, ES, FI, GB, GD, GE, GH, GM, GT, HN, HR, HU, ID, IL, IN, IS, JP, KE, KG, KM, KN, KP, KR, KZ, LA, LC, LK, LR, LS, LT, LU, LY, MA, MD, ME, MG, MK, MN, MW, MX, MY, MZ, NA, NG, NI, NO, NZ, OM, PG, PH, PL, PT, RO, RS, RU, SC, SD, SE, SG, SK, SL, SM, SV, SY, TJ, TM, TN, TR, TT, TZ, UA, UG, US, UZ, VC, VN, ZA, ZM, ZW.
- (84) **Designated States (unless otherwise indicated, for every kind of regional protection available):** ARIPO (BW, GH, GM, KE, LS, MW, MZ, NA, SD, SL, SZ, TZ, UG, ZM, ZW), Eurasian (AM, AZ, BY, KG, KZ, MD, RU, TJ, TM), European (AT, BE, BG, CH, CY, CZ, DE, DK, EE, ES, FI, FR, GB, GR, HR, HU, IE, IS, IT, LT, LU, LV, MC, MT, NL, NO, PL, PT, RO, SE, SI, SK, TR), OAPI (BF, BJ, CF, CG, CI, CM, GA, GN, GQ, GW, ML, MR, NE, SN, TD, TG).
- Published:**
— with international search report (Art. 21(3))



WO 2009/154501 A1

(54) **Title:** METHOD AND DEVICE FOR NONCONTACT DATA EXCHANGE AND CHARGING OF ACCUMULATOR BATTERIES OF SELF-CONTAINED LOGGING TOOLS

(57) **Abstract:** The invention relates to the area of geophysics and, in particular, to the methods of noncontact data exchange between self-contained logging tools and a surface reader, as well as to the problem of noncontact charging of accumulator batteries of self-contained logging tools. The tool can operate on a self-contained basis and required operations can be performed on the surface with the lubricator closed because induction communication is established between the induction coil wound round the radiotransparent adapter under the lubricator, and the induction coil placed in the charging and telemetering module the body of which is made of radiotransparent material. A core is used for more efficient transmission of energy between the coils. The logging tools equipped with off-line memory and suspended on a wireline are tripped in a hole by using a hoist. The steel wireline passes through sealed stuffing boxes in the upper part of the lubricator. After a measurement run has been complete, the logging tools with the data recorded are tripped to the surface by the hoist through the wellhead equipment. An adapter made of fiber-glass reinforced plastic is installed between the lubricator and the wellhead equipment. 5 illustrations, 5 subclaims.

Method and Device for Noncontact Data Exchange and Charging of Accumulator Batteries of Self-Contained Logging Tools

The invention relates to the area of geophysics and, in particular, to the methods of noncontact data exchange between self-contained logging tools and a surface reader, as well as to the problem of noncontact charging of accumulator batteries of self-contained logging tools.

When performing logging operations in oil wells and gas wells, measuring tools are usually tripped in a hole by using two methods, namely, by using a cable or a wireline. The first method uses a load-bearing logging cable through which data are transmitted to the surface and the logging tools are powered. The advantage of this method is that it allows continuous data transmission. Due to big diameter and heavy weight of the insulated and armoured cable, it is difficult to trip tools in high-pressure holes. Such a cable is serviced by a self-propelled unit designed for cable (wireline) operations, which results in additional expenses. The second method uses a plain wireline to trip tools in a hole. In this case, the tools shall have self-contained power supply and memory units for temporary storage of the logging data. The wireline is usually 1 to 2 mm thick and weighs tens of kilograms. Unlike the cable, the wireline is easier to service and a conventional tigger hoist is used for tripping operations.

The main disadvantages of using a logging cable in the logging operations are that it is difficult to trip logging tools in high-pressure holes and that it is difficult to seal the hole because of big diameter of the cable. Using a plain wireline eliminates both of these problems, but retains laborious tool-

retrieving operations for subsequent reading and accumulator battery charging. A dedicated sealing device called 'lubricator' to be installed above the production tree is used for operations in producing wells. There is a stuffing box in the upper part of the lubricator to provide sealed passage for a

logging cable, plain wireline or flexible pipes, depending on the operations performed. In case of a high pressure drop, a series of stuffing boxes designed for required pressure is installed. The lubricator design allows removal and suspension of logging tools without unsealing the hole. Prior to tripping the logging tools in the hole, a required pressure is built in the lubricator. By opening the valve, the logging tools can be tripped in the hole, using a hoist.

Self-contained logging tools are equipped with recorders which record data into the internal memory, and the data are then read on the surface by a surface reader (or a surface computer). The lubricator shall be disassembled for maintenance, data reading and accumulator battery charging purposes. This operation is a rather laborious and is associated with the hazard of fluid or oil spillage. Moreover, each such operation takes a lot of working time and requires the availability of highly skilled personnel.

There are known methods of data exchange between the logging tools and the elements of the hole in the wireline and drilling operation practices. Several inventions (US 5.971.072, US 3.534.310) describe induction devices installed in wireline well-completion tools and self-contained induction transmitters installed in certain areas of a drilling string. When such a tool approaches to a self-contained transmitter, data are exchanged and certain operations are performed. These may be tool stopping and fixing operations, perforating charge initiation operations and other well-completion operations.

Also, there are known methods of noncontact induction communication between a bundle of tools in the hole and a surface reader (Patent Application US 20060244628). In this engineering solution, the wireline with which the logging tools are tripped in the hole is used as an antenna for transmission of real-time data. The lower end and the upper end of the wireline are equipped with induction couplers. The data from the logging tools come to a data

transmission device connected to the lower coupler. Many meter-long wireline which is used for tripping the logging tools in the hole actually operates as a long antenna for transmission of frequency-modulated data. However, the disadvantage of this system is that in case of a strong attenuation of the high-frequency data signal in the antenna, it is necessary to use radio frequency followers to be installed along the whole length of the wireline. The use of such followers allows the data signal power to be maintained at a required level. However, the logging tool tripping operations are considerably complicated by the fact that the frequency followers are to be placed and serviced on a wireline.

The closest engineering solution is the method which is proposed in Patent EP 0678880 and which uses a downhole pressure and temperature measuring tool made in such a way as to allow its repair and rehabilitation without the need to shut in the well. This tool is tripped in the hole, using flexible pipes, and is installed coaxially on the induction system which is permanently mounted in a retrievable gaslift valve mandrel. The flexible pipes are then tripped out of the hole while the tool remains in the mandrel. The cable connected to the induction system is brought out to the surface through the annulus; the cable is used for powering the tool and for reading the real-time data. However, due to the use of the power cable and due to the connection to the surface reading system, this tool cannot be used in hard-to-reach areas which require self-contained operation.

The technical result of the invention claimed consists in the development of a self-contained device for making noncontact data exchange and a method for charging accumulator batteries of self-contained logging tools by means of induction communication. The important advantage of the engineering solution proposed is that the tool operates on a self-contained basis and that required operations are performed on the surface with the lubricator closed.

Induction communication is established between an induction coil wound round a radiotransparent adapter under the lubricator, and an induction coil placed in a charging and telemetering module the body of which is made of radiotransparent material. A core is used for more efficient transmission of energy between the coils.

The invention proposed is shown in Figure 1, Figure 2, Figure 3 and Figure 4.

Figure 1 shows the general logging tool tripping scheme based on the use of a plain wireline, and the position of the radiotransparent adapter on the wellhead equipment. According to Figure 1, logging tools (1) equipped with off-line memory are suspended on a wireline (2) and are handled by a hoist. The steel wireline passes through sealed stuffing boxes (not shown) in the upper part of the lubricator (4). After a measurement run has been complete, the logging tools with the data recorded are tripped to the surface by the hoist through the wellhead equipment (5). An adapter (3) made of fiber-glass reinforced plastic is installed between the lubricator (4) and the wellhead equipment.

Figure 2 shows the longitudinal section of the radiotransparent adapter during the moment of maximum approach of the internal induction coil to the external induction coil, where 12 is the core, 13 is the external induction coil and 14 is the induction coil which together constitute an induction system (20), 17 is the charging and telemetering module, 19 is the external reader.

When a bundle of the logging tools passes through the radiotransparent adapter and, in particular, when the tools are tripped to the surface, low alternating voltage is supplied to the external induction coil (13) wound round the internal surface of the radiotransparent adapter (3). The current from the winding (13) is measured by the external reader (19). The charging and telemetering module (17) is installed in the upper part of the bundle of the

logging tools and is used for data exchange between the logging tools and the external reader (19).

When the charging and telemetering module (17) equipped with the induction coil (14) and the core (12) approaches to the radiotransparent adapter (3), the current in the winding (13) increases due to amplification of induction communication between the windings. Maximum current in the induction coil (13) indicates that the hoist should be stopped and that the data exchange and accumulator battery charging processes should be started. The combination of the winding (14), the external winding (13) and the core (12) will be described hereinafter as the induction system (20). A data reading instruction is sent by using induction communication to the telemetering module (17) and the telemetering module then starts data transmission from the logging tools through the induction coil (14) to the induction coil (13) and further to the external unit (19) and to the surface personal computer.

The radiotransparent adapter (3) and the body of the telemetering module (17) shall be made of a sufficiently strong material (designed for hydrostatic pressure inside the wellhead equipment) characterized by low absorption of radio-waves in a range of 50 to 100,000 Hz. Radiotransparent walls of the adapter (3) and of the body of the telemetering module (17) allow the data exchange and accumulator battery charging processes to run with minimum energy losses. The most suitable material for implementation of this invention is fiber-glass reinforced plastic characterized by high mechanical strength properties and low losses in the said frequency range. Other radiotransparent materials (composites or ceramics) are not as good as fiber-glass reinforced plastic in terms of mechanical strength and manufacturability, but they can still be used for implementation of this invention. The length of the radiotransparent adapter (16) is selected to be 1.5 to 2 times greater than the length of the induction system (20) in order to reduce the induction signal losses at the terminal conducting elements of the adapter. The internal

diameter of the radiotransparent adapter (16) is selected to be equal to the internal diameter of the downstream wellhead equipment in order to allow free movement of the logging tools.

The general scheme of the external reader (19) is shown in **Figure 3**. In this Figure, the induction coil (24) is part of the induction system (20) through which accumulator batteries are charged and data are exchanged with the logging tool. The 220V, 50 Hz industrial network is used as the power source for charging the accumulator batteries. Data are exchanged at a high frequency relative to the low frequency of the industrial power supply network. The low-frequency accumulator battery charging current and high-frequency data signal are mixed in a mixer installed on a transformer (23). Winding I of the transformer (23) is used for connection to the industrial network, winding II is used for connection to the transceiver (21) of the surface unit and winding III is used for connection to the primary (external) winding of the induction system (20). An overvoltage protection module (22) is used for protection of the transceiver against the voltage coming from charging winding I to transceiver winding II. The transceiver (21) is connected to the input of the personal computer where data which have been read from the logging tool(s) are stored and processed.

It is possible to use standard frequency-shift keying (FSK) modems as the transceiver modem, e.g. widespread CMX469 modems manufactured by *CML Microcircuits Ltd*, USA. With such modems, the maximum speed of data exchange with the logging tool is equal to 4,800 bits per second, which is quite sufficient for most applications. The operating frequencies range from 2,400 to 4,800 Hz at the modem output, which allows easy extraction of the high-frequency data signal against the background of 60 Hz charging current by using simple first-order filters. To increase the data exchange speed, it is possible to use upgraded FX929 modems (up to 9,600 bits per second) manufactured by *CML Microcircuits Ltd*, or standard Manchester

encoders/decoders (e.g. 588VG6 model manufactured by *Intergal* Plant, Republic of Belarus, or HD6408 model manufactured by *Intersil*, USA). In the latter case, Manchester encoders/decoders arrange communication channels at a data exchange speed of up to 1 megabits per second, and the communication channel capacity is only limited by the properties of the transformer (23) and of the induction system (20) with the winding (24).

The block diagram of the charging and telemetering module (17) is shown in **Figure 4**. Low-frequency accumulator battery charging voltage is induced on winding I of the induction system (20) and is rectified in the rectifier unit (32) and is then converted into constant voltage in the capacitor unit (33). The charger (34) directly controls the accumulator battery (35) charging process. Transceiver winding II of the induction system (20) is connected to the telemetering unit (36), which is similar to the units (21) and (22) of the surface module.

Example of Embodiment of This Invention.

A test unit (Figure 5) was used for evaluation of the efficiency of the method proposed. A core (12) made of 1000NN-grade ferrite (standard size: 10x100) is wound with the secondary winding (14) (2,000 turns of 0.25 mm PETV-1 wire) which is wound with glass-fiber cloth to achieve an external winding diameter of 28 mm (taken to be equal to the external diameter of the logging tools). The primary winding (13) is wound round a hollow cylinder made of fiber-glass reinforced plastic and having an internal diameter of 50 mm (selected to be equal to the internal diameter of the production tree). The wire type and the number of turns are taken to be the same as in the secondary winding. Both windings are immersed into a beaker (40) filled with an aqueous solution of sodium chloride at a concentration of 50 g/L (simulation of formation water). The primary winding (13) is connected through an insulating transformer (42) (transformation ratio: 1:1) to a LATR-2,5-type

adjustable-ratio autotransformer (41). The secondary winding (14) is loaded at a resistor (47) (resistance: 100 ohms; power: 5 watts). The voltage and the current across the primary winding (13) are controlled by a voltmeter (43) and an ammeter (44). The voltage and the current across the secondary winding (14) are similarly controlled by a voltmeter (45) and an ammeter (46). The voltage supplied to the primary winding of the induction system (20) is changed by changing the position of the controller of the autotransformer (41). This voltage is selected in such a way as to prevent the saturation of the core (12).

The efficiency was evaluated by the following formula: $\eta = ((V2 \cdot I2) / (V1 \cdot I1)) \cdot 100\%$, where V2 and I2 are the indications of the voltmeter (45) and the ammeter (46) in the secondary winding (14), and V1 and I1 are the indications of the voltmeter (43) and the ammeter (44) in the primary winding (13). Efficiency of about 20% was achieved in this test unit, and the dissipated power at the resistor (47) was about 2 watts, which is quite sufficient for charging accumulator batteries in the logging tools in a reasonable time. The preliminary calculations show that it is possible to increase the efficiency up to 50% by optimizing the design and the material of the core (12) and by optimizing the number of turns and the diameter of the wire used in the windings, even in case of water-oil mixtures having a higher salt content. Such optimization will increase the power transmitted to the secondary winding and will consequently reduce the accumulator battery charging time.

Claims

1. Method for noncontact data exchange and charging of accumulator batteries of self-contained logging tools, according to which logging tools equipped with off-line memory are suspended on a wireline and can be handled inside and outside the hole by using a hoist, with the wireline passing successively through the lubricator, the radiotransparent adapter and the wellhead equipment. A charging and telemetering module is installed in the upper part of the bundle of the logging tools and is moved inside the radiotransparent adapter to allow data exchange between the logging tools and the external reader and to charge the accumulator batteries of the logging tools.

2. Method according to paragraph 1, characterized in that a data reading instruction is sent by using induction communication to the telemetering module and the telemetering module then starts data transmission from the logging tools to the external unit and to the surface computer.

3. Method according to paragraph 1, characterized in that the radiotransparent adapter is made of fiber-glass reinforced plastic.

4. Method according to paragraph 1, characterized in that the length of the radiotransparent adapter is selected to be 1.5 to 2.0 times greater than the length of the induction system.

5. Device for noncontact data exchange and charging of accumulator batteries of self-contained logging tools, which consists of a radiotransparent adapter placed on a wireline above the logging tools, and of a charging and telemetering module placed on a wireline in the upper part of the bundle of the logging tools. When moving, the module is able to pass through the radiotransparent adapter the internal radiotransparent surface of which has been wound with the external winding of the induction coil, connected to the external reader. The charging and telemetering module consists of the

induction coil winding and the core placed inside the induction coil, with the external induction coil winding, the induction coil winding and the core constituting an induction system.

6. Device according to paragraph 5, characterized in that the induction coil is part of the induction system through which accumulator batteries are charged and data are exchanged with the logging tool. The low-frequency accumulator battery charging current and high-frequency data signal are mixed in a mixer installed on a transformer. Transformer winding I is connected to the industrial network, winding II is connected to the transceiver of the surface unit through an overvoltage protection module and winding III is connected to the external winding of the induction system. The transceiver is connected to the input of the personal computer which stores and processes the data read from the logging tool(s).

7. Device according to paragraph 5, characterized in that the charging and telemetering module includes accumulator batteries which are connected to the capacitor unit through the charger connected through the rectifier unit to winding I of the induction coil of the induction system, while transceiving winding II of the induction coil of the induction system is connected to the telemetering unit.

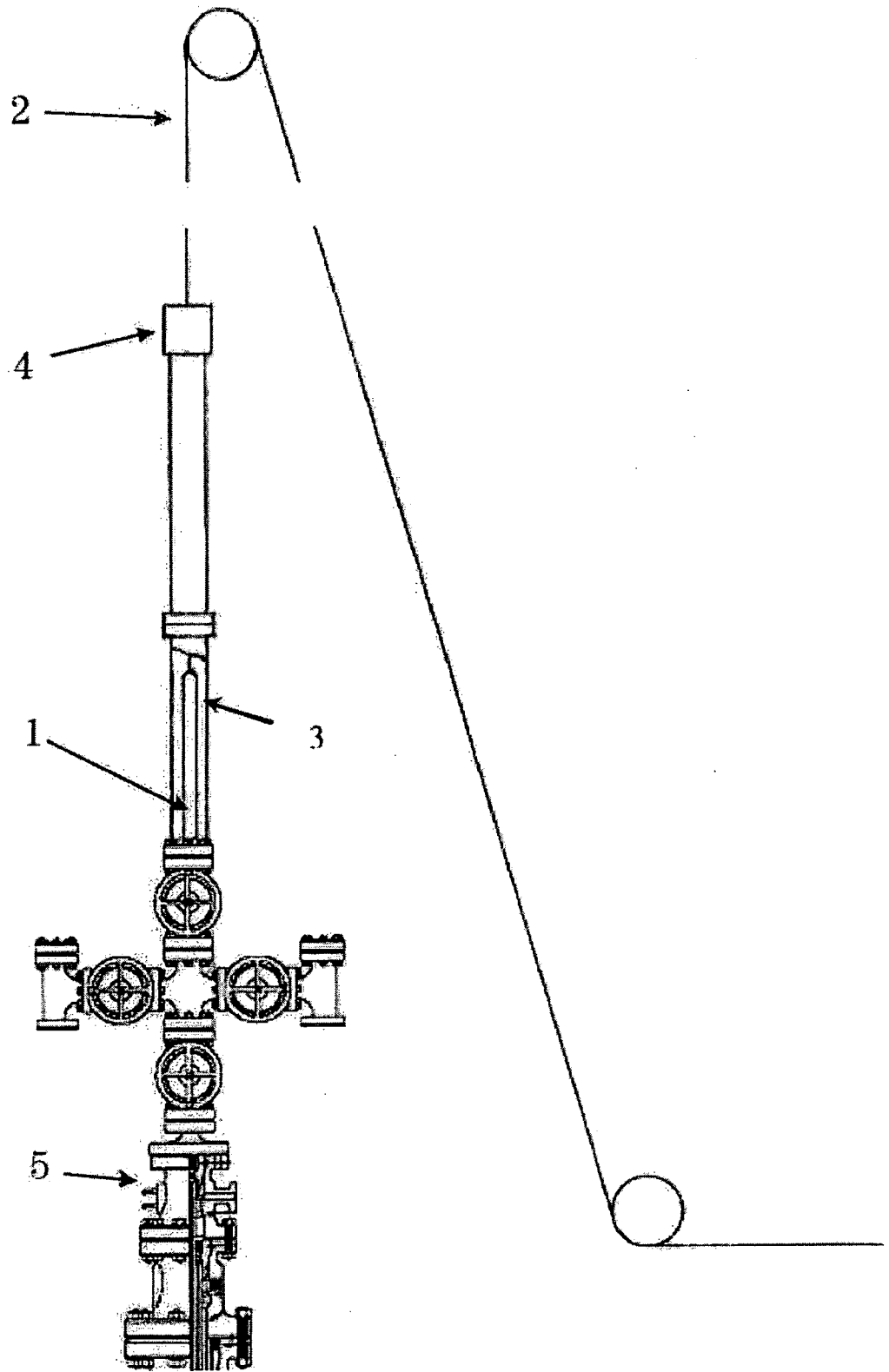

Fig. 1

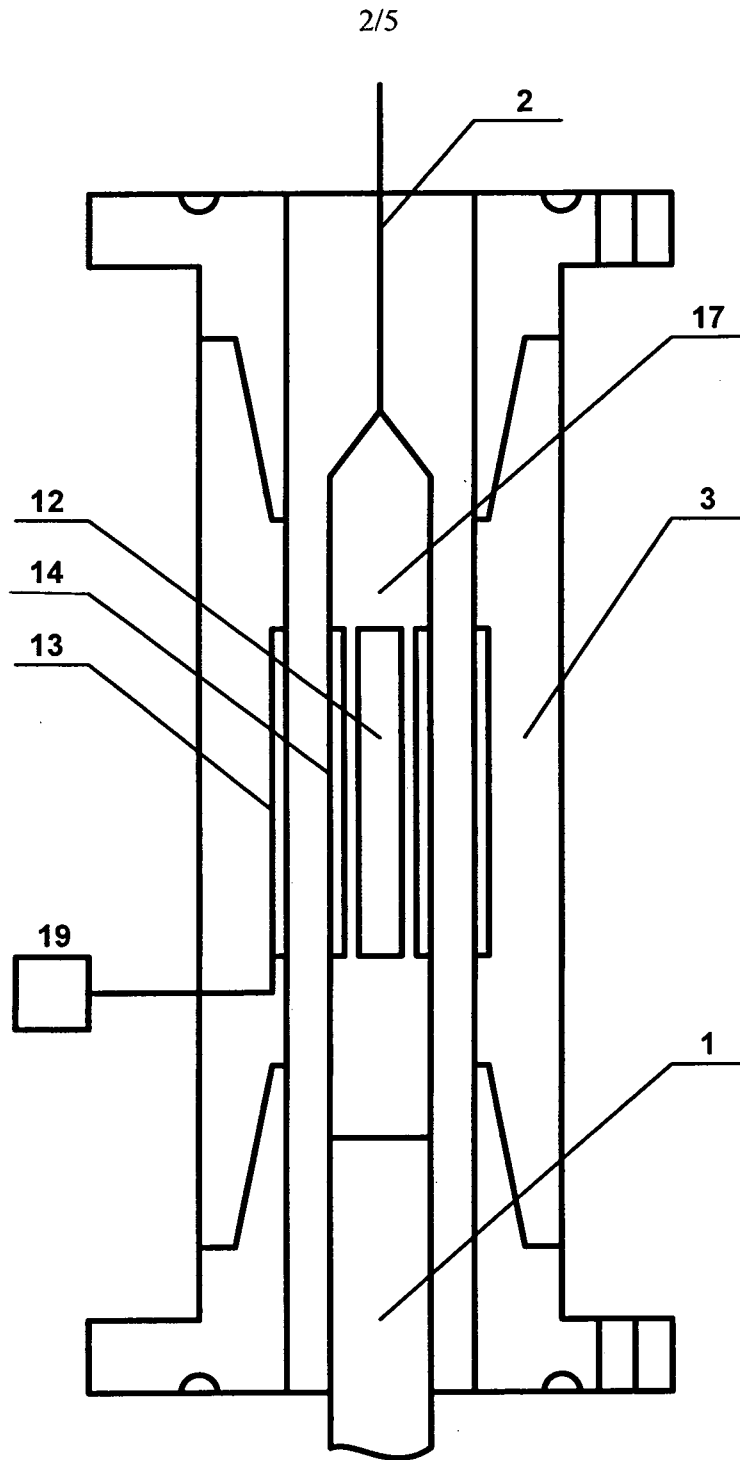

Fig. 2

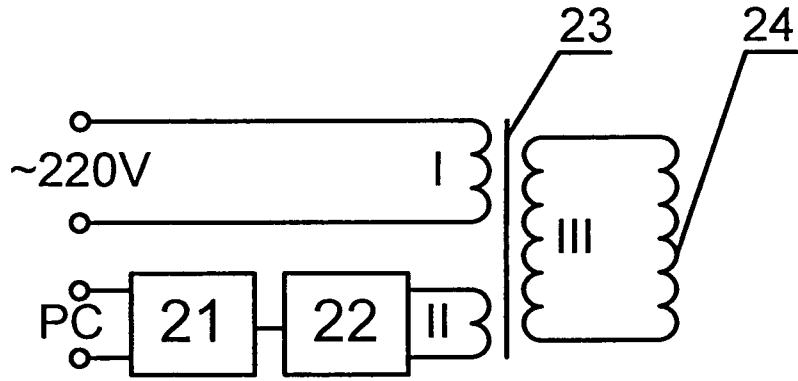

Fig. 3

4/5

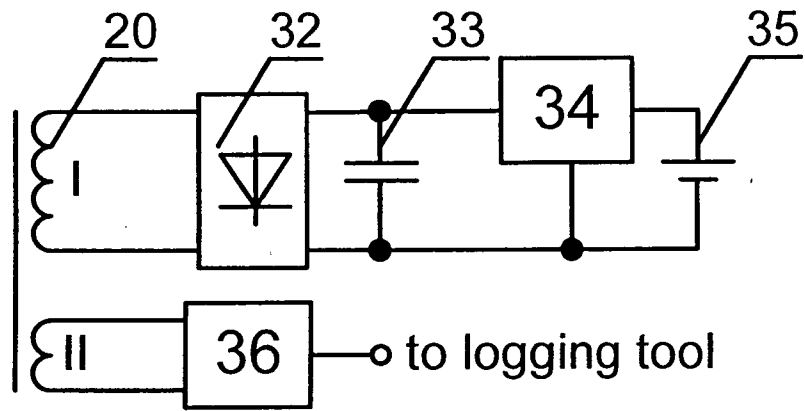

Fig. 4

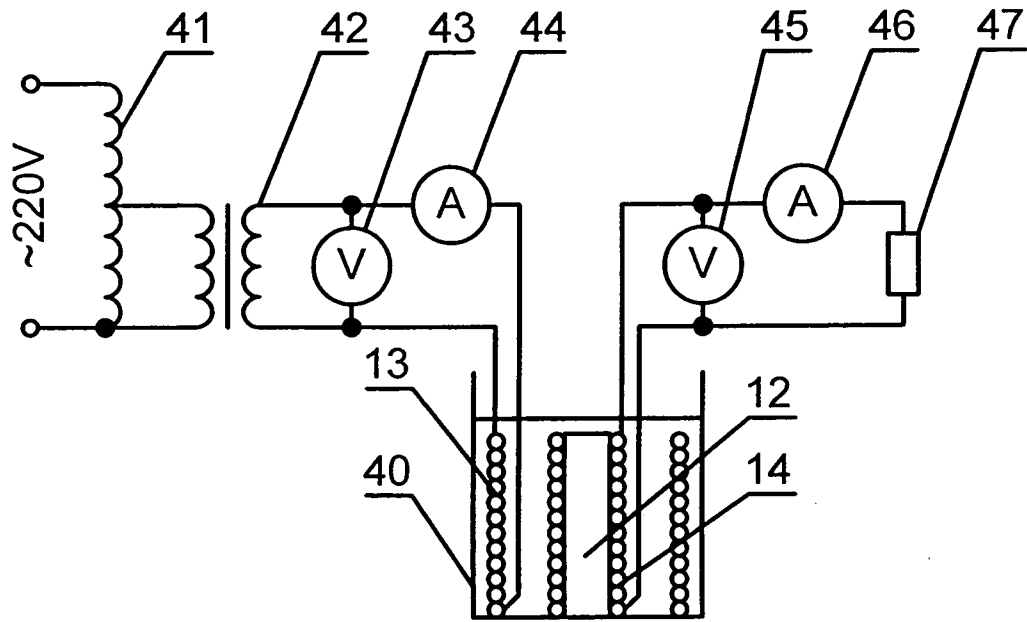

Fig. 5

INTERNATIONAL SEARCH REPORT

International application No. PCT/RU 2008/000388

A. CLASSIFICATION OF SUBJECT MATTER	H02J 7/00 (2006.01) E21B 47/12 (2006.01) H01F 38/00 (2006.01)
According to International Patent Classification (IPC) or to both national classification and IPC	

B. FIELDS SEARCHED
Minimum documentation searched (classification system followed by classification symbols) G01V 3/00, 3/18, 3/26-3/30, 3/34, E21B 47/00, 47/01, 47/09, 47/12, 23/00, 23/14, H01F 38/00, 38/14, H02J 7/00

Documentation searched other than minimum documentation to the extent that such documents are included in the fields searched
Electronic data base consulted during the international search (name of data base and, where practicable, search terms used) RUPAT, RUPAT OLD, RUPAT NEW, RUABRU, PatFT, EAPATIS, PAJ, PCT, Esp@cenet

C. DOCUMENTS CONSIDERED TO BE RELEVANT

Category*	Citation of document, with indication, where appropriate, of the relevant passages	Relevant to claim No.
A	RU 24702 U1 (OAO "SIBNEFT-NOYABRSKNEFTEGAZGEOFIZIKA" et al.) 20.08.2002	1-7
A	RU 16316 U1 (OTKRYTOE AKTSIONERNOE OBSHESTVO "NAUCHNO-PROIZVODSTVENNY TSENTR PO GEOFIZICHESKIM RABOTAM "TVERGEOFIZIKA") 20.12.2000	1-7
A	RU 57816 U1 (OTKRYTOE AKTSIONERNOE OBSHESTVO "INZHENERNO-PROIZVODSTVENNAYA FIRMA SIBNEFTEAVTOMATIKA") 27.10.2006	1-7
A	EP 0678880 A1 (PANEX CORPORATION) 25.10.1995	1-7
E	RU 2338064 C1 (SHLYUMBERGER TEKNOLODZHI B.V.) 10.11.2008	1-7

<input type="checkbox"/> Further documents are listed in the continuation of Box C.	<input type="checkbox"/> See patent family annex.
---	---

<p>* Special categories of cited documents:</p> <p>"A" document defining the general state of the art which is not considered to be of particular relevance</p> <p>"E" earlier application or patent but published on or after the international filing date</p> <p>"L" document which may throw doubts on priority claim(s) or which is cited to establish the publication date of another citation or other special reason (as specified)</p> <p>"O" document referring to an oral disclosure, use, exhibition or other means</p> <p>"P" document published prior to the international filing date but later than the priority date claimed</p>	<p>"T" later document published after the international filing date or priority date and not in conflict with the application but cited to understand the principle or theory underlying the invention</p> <p>"X" document of particular relevance; the claimed invention cannot be considered novel or cannot be considered to involve an inventive step when the document is taken alone</p> <p>"Y" document of particular relevance; the claimed invention cannot be considered to involve an inventive step when the document is combined with one or more other such documents, such combination being obvious to a person skilled in the art</p> <p>"&" document member of the same patent family</p>
---	---

Date of the actual completion of the international search 05 March 2009 (05.03.2009)	Date of mailing of the international search report 19 March 2009 (19.03.2009)
---	--

Name and mailing address of the ISA/RU FIPS Russia, 123995, Moscow, G-59, GSP-5, Berezhkovskaya nab., 30-1 Facsimile No. 243-3337	Authorized officer I. Konycheva Telephone No. (499) 240-2591
--	--