

Jan. 7, 1964

M. K. REAR  
EXCAVATING MACHINE

3,116,567

Filed March 6, 1962

2 Sheets-Sheet 1

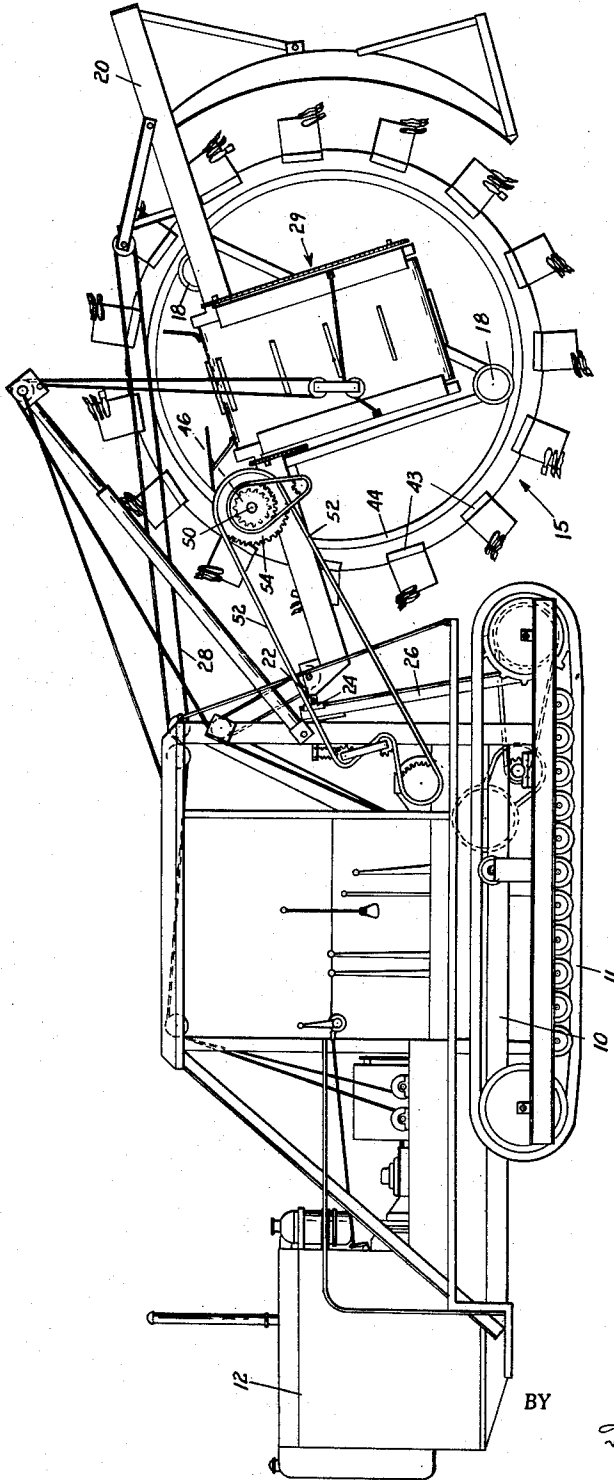

FIG. 1

INVENTOR  
MELVIN K. REAR

BY

*Teare, Fetzer & Teare*  
ATTORNEYS

Jan. 7, 1964

M. K. REAR

3,116,567

EXCAVATING MACHINE

Filed March 6, 1962

2 Sheets-Sheet 2

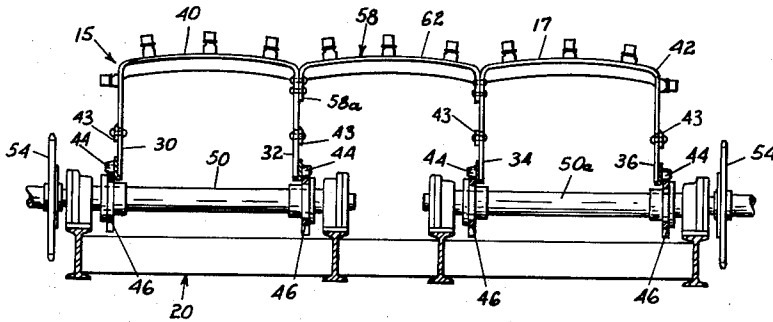

Fig. 2

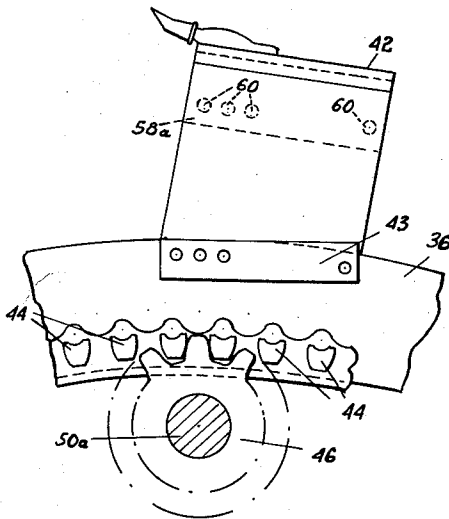

Fig. 3

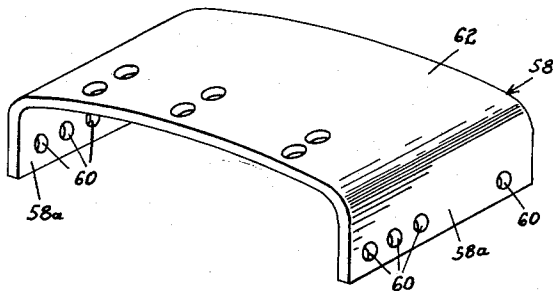

Fig. 4

INVENTOR  
MELVIN K. REAR

BY

*Teare, Fetzer + Teare*  
ATTORNEYS

1

3,116,567

## EXCAVATING MACHINE

Melvin K. Rear, Chesterland, Ohio, assignor to The Cleveland Trencher Company, Cleveland, Ohio, a corporation of Ohio

Filed Mar. 6, 1962, Ser. No. 177,771

2 Claims. (Cl. 37-97)

This invention relates in general to excavating or trenching machines and more particularly to a novel digging unit of the rotary wheel type for a trenching machine.

The digging unit of the conventional rotary wheel type excavating machine comprises a pair of laterally spaced rings or side rims bridged by aligned digging buckets disposed around the outer peripheries of the side rims, and with such side rims and associated buckets being driven by means of drive gears mounted on the drive shaft extending through the digging unit and coacting with drive lugs or teeth on the outer sides of the side rims, to rotate the digging unit. The drive gears are conventionally driven from a power plant mounted on the machine chassis adjacent the forward end of the latter. In the excavating field there is an increasing demand for excavating or trenching machines of greater digging capacities and with the ability to dig wider trenches, which has resulted in the use of greater widths for the excavating or digging buckets of the digging wheel. This greater width of bucket has required that the buckets be made stronger, and thus heavier, to be able to withstand the stresses occasioned by the digging operations.

The present invention provides a digging unit of the rotary wheel type comprising a series of laterally disposed, paired side rims or plates, each pair of the side rims being bridged by more or less conventional width and weight of buckets, and with such laterally disposed buckets on the bucket bridged paired side rims being connected by a partial bucket, resulting in an integral multi-part arrangement providing a large width of digging unit bucket with a materially lighter weight as compared to a single continuous bucket extending the full width of a large width high capacity digging unit.

Accordingly, an object of the invention is to provide a novel digging unit of greater than conventional width for a mobile excavating machine.

Another object of the invention is to provide a large width digging unit for a mobile excavating machine comprised of a plurality of laterally disposed buckets mounted around a wheel and connected to one another by partial bucket means, resulting in a lighter weight of digging unit as compared to a single continuous bucket extending the full width of the digging unit.

A more specific object of the invention is to provide an excavating machine having a wider width of rotary wheel type digging unit thereon as compared to conventional rotary wheel type digging units, and wherein the digging unit includes two pairs of laterally disposed side plates or rims with conventional buckets bridging each respective pair of side plates, and with a partially formed transversely extending bucket connecting each pair of laterally disposed conventional buckets, to form an integral multi-part bucket arrangement extending the full width of the digging unit.

Another object of the invention is to provide a novel multi-part bucket arrangement which is adapted to extend the full width of a high capacity rotary-type digging wheel, and which bucket possesses higher strength in proportion to its weight as compared to heretofore known arrangements.

A still further object of the invention is to provide a mobile excavating machine having a novel bucket equipped digging unit mounted thereon, and wherein the digging

2

unit may be formed of generally standard parts heretofore utilized in conventional rotary wheel type digging units, and with such standard parts being disposed in side-by-side orientation and connected by partial buckets, to form an integral arrangement of a multi-part bucket extending the full width of the digging unit.

Other objects and advantages of the invention will be apparent from the following description taken in conjunction with the accompanying drawings wherein:

FIG. 1 is a side elevational view of an excavating machine having a digging unit embodying the instant invention:

FIG. 2 is an enlarged, fragmentary, transverse section taken through the digging unit of FIG. 1;

FIG. 3 is a fragmentary, side elevational view of a portion of one of the side plates of the wheel type digging unit, and illustrating one of the drive gears coacting with the drive teeth or lugs on the outer confronting side of the side plate, for rotating the digging unit with respect to its supporting boom frame;

FIG. 4 is a perspective view of one of the partial buckets used to connect the laterally disposed, paired buckets of the digging wheel, to provide a multi-part bucket extending the full width of the large width, high capacity digging unit.

Referring now to the drawings, there is illustrated a wheel type excavating or trenching machine. The machine broadly comprises a chassis frame 10 supported by tractor treads 11. A motor 12 is mounted at one end of the frame and may be drivingly connected to the tractor treads by any suitable or conventional means.

The excavating wheel or digging unit 15 comprises laterally spaced side plates or rings of generally conventional size and weight, joined together at their peripheries by generally U-shaped excavating buckets. The side plates may be supported for rotary movement by a plurality of rollers 13, supported in the generally conventional manner by the generally horizontally extending boom frame 20. The inner end of the boom may be pivotally connected as at 22 to carriage means 24 mounted for generally vertical movement on mast structure 26 carried by the rearward end of the chassis frame 10. The boom and associated digging wheel may be adjusted in a generally vertical plane by means of cable and pulley system 23, and in the conventional manner.

Discharge conveyor mechanism 29 may extend transversely through the digging wheel and is adapted to receive excavated material from the digging wheel in the conventional manner and discharge the same to a side of the machine.

In accordance with the instant invention, the digging wheel may comprise a series of laterally spaced paired side plates or rings 30, 32 and 34, 36 (FIG. 2). The plates 30, 32 are bridged by the more or less conventional width and weight bucket members 40, and the plates 34, 36 are bridged by the more or less conventional bucket members 42. Such buckets may have bucket lugs 43 secured to the side walls thereof in the conventional manner for connecting the buckets to the peripheries of the respective side rings. The buckets are preferably detachably connected to the associated side rings, and as by means of threaded fasteners, for convenient removal thereof. The side plates 32 to 36 may each have drive lugs or teeth 44 mounted on the exterior side thereof, and with said drive lugs coacting with a respective drive gear member 46 fixedly mounted on drive shafts 50, 50a and in the conventional manner. Drive shafts 50, 50a are adapted to be driven in synchronism by the aforementioned motor unit 12 mounted on the machine chassis, and via a chain and sprocket drive 52 to the associated drive sprocket wheel 54 mounted adjacent the outer end of each drive shaft.

Referring now in particular to FIGS. 2 and 4, each pair of laterally spaced buckets 40, 42 are connected by a preferably detachable U-shaped plate or partial bucket 53 which bridges the associated pair of buckets and connects the latter together into an integral multi-bucket arrangement. The side walls 53a of the partial bucket may have openings 60 therethrough adapted for alignment with complementary openings in the confronting side walls of buckets 40 and 42, for receiving fastener means, such as for instance threaded fasteners, there-through. The openings 60 are so arranged with respect to the coacting openings in the buckets 40, 42 that the slightly arcuate top wall 62 of partial bucket 53 is in general alignment with the top walls of the associated buckets, and as best shown in FIG. 2 of the drawings. The height of the side walls 53a of partial bucket members 53 are preferably so arranged with respect to the width of the top wall 62 that twice the height of a side wall 53a is less than one-half the width of the top wall.

The buckets may have conventional roter teeth mounted on the forward lip thereof, and in conventional manner, and with the aforementioned bridging partial bucket 53 also providing a support for mounting conventional roter teeth thereon, and in the conventional manner.

The present arrangement enables the production of an excavation having a substantially flat bottom, and yet the weight of the digging unit is materially decreased over that which would be necessary if a single bucket extending the full transverse width of the digging unit was utilized. With the present arrangement, an excavation of eight feet wide may be readily produced, and with a relatively light weight digging unit, heretofore unknown in the excavating art. Moreover, with the multi-part arrangement, the overall diameter of the digging unit is decreased over that which would be necessary if utilizing buckets extending continuously for the full transverse width of the digging unit, thereby providing a more compact unit. The detachable relationship of the parts of the multi-part bucket assembly provides for expeditious replacement of a single part that has become worn or damaged, without necessitating the replacement of the entire bucket assembly. Since the drive shafts 50, 50a are driven in unison via sprocket members 54 from the power unit 12, and therefore drive in unison the plurality of drive gears 46, there is no twist or torque applied to the digging unit.

The buckets including the partial buckets may include conventional back members or back walls for closing each bucket, and with such back walls preferably being detachable, and the buckets and partial buckets may also embody the well-known tines thereon extending downwardly towards and intermediate the associated side rims or rings for use in relatively heavy soils where the excavated material will not pass readily between the tines.

From the foregoing discussion and accompanying drawings, it will be seen that the present invention provides a novel digging unit for a mobile excavating machine, and with such digging unit having a lighter weight and greater

strength for a predetermined width of digging unit, and being formed of a plurality of buckets disposed in lateral relation on a series of rims or rings of the digging unit, and with the laterally disposed buckets being bridged by partial buckets.

The terms and expressions which have been used, are used as terms of description and not of limitation and there is no intention in the use of such terms and expressions of excluding any equivalents of any of the features shown or described, or portions thereof, and it is recognized that various modifications are possible within the scope of the invention claimed.

I claim:

1. In a mobile excavating machine comprising a chassis, a power unit mounted on the chassis, a digging unit support mounted on the chassis, a rotary digging wheel mounted on said support for rotary movement in a generally vertical plane extending longitudinally of the machine, a pair of drive shafts rotatably mounted on said support and extending transversely of said wheel, means supported adjacent the outer ends of said drive shafts and operably connecting said drive shafts to said power unit for driving said shafts, said wheel comprising pairs of laterally spaced equal size annular side rings, means co-acting between said drive shafts and each of said rings for rotating the latter in unison on said support, equal size excavating buckets bridging the rings of each of said pairs, each of said buckets comprising side walls attached to and projecting generally radially outwardly from the respective pair of said rings and a bridging outer wall connecting said side walls, the buckets, including said outer walls, on said pairs of rings being aligned with respect to one another transversely of said wheel and other excavating bucket means extending transversely of the wheel between the pairs of said rings and connecting the laterally disposed buckets thereon into integral bucket units, each of said bucket means comprising a U-shaped member defining side walls and a bridging outer wall, means connecting said side walls of the U-shaped member to the confronting side walls of respective pairs of laterally disposed excavating buckets, and with the outer wall of said U-shaped member being disposed in alignment with and being of the same lengthwise extent in a direction longitudinally of said machine, as the outer walls of the respective pair of buckets.

2. A mobile excavating machine in accordance with claim 1, wherein said bucket means and said excavating buckets include means detachably attaching the same together.

#### References Cited in the file of this patent

##### UNITED STATES PATENTS

1,110,931	Heck	Sept. 15, 1914
1,239,727	Schlatter	Sept. 11, 1917
1,455,206	Howe	May 15, 1923

##### FOREIGN PATENTS

1,823	Netherlands	of 1917
-------	-------------	---------