



## INTERNATIONAL APPLICATION PUBLISHED UNDER THE PATENT COOPERATION TREATY (PCT)

(51) International Patent Classification <sup>6</sup> : <b>B60C 5/10</b>	<b>A1</b>	(11) International Publication Number: <b>WO 97/25215</b> (43) International Publication Date: 17 July 1997 (17.07.97)
<p>(21) International Application Number: PCT/GB97/00079</p> <p>(22) International Filing Date: 10 January 1997 (10.01.97)</p> <p>(30) Priority Data: 9600662.2      12 January 1996 (12.01.96)      GB</p> <p>(71) Applicant (for all designated States except US): JANNOCK LIMITED [GB/GB]; 463 Oxford Road, Reading, Berkshire RG3 1HD (GB).</p> <p>(72) Inventor; and (75) Inventor/Applicant (for US only): BAKER, Rhoderick, Jonathan, Spencer [GB/GB]; 463 Oxford Road, Reading, Berkshire RG3 1HD (GB).</p> <p>(74) Agent: ROCK, Olaf, Colin; Trelawn, The Green, Cassington, Witney, Oxon OX8 1DN (GB).</p>		<p>(81) Designated States: AL, AM, AU, AZ, BA, BB, BG, BR, BY, CA, CN, CU, CZ, EE, GE, HU, IL, IS, JP, KE, KG, KP, KR, KZ, LC, LK, LR, LS, LT, LV, MD, MG, MK, MN, MW, MX, NO, NZ, PL, RO, RU, SD, SG, SI, SK, TJ, TM, TR, TT, UA, UG, US, UZ, VN, European patent (AT, BE, CH, DE, DK, ES, FI, FR, GB, GR, IE, IT, LU, MC, NL, PT, SE).</p> <p><b>Published</b> <i>With international search report. Before the expiration of the time limit for amending the claims and to be republished in the event of the receipt of amendments.</i></p>
<p>(54) Title: INNER TUBE</p>		
<p>(57) Abstract</p>		
<p>An inner tube for use with a pneumatic tyre casing having an internal volume with a specific mean length and a specific cross section; the inner tube is in the form of a thin flexible cylinder with closed ends; the ends being tapered or stepped so that when located within a pneumatic tyre as aforesaid the ends of the inner tube are adapted to overlay one another to provide a scarfed joint between the ends, the overlapping section having a cross section substantially similar to that of the remainder of a non-overlapping section of tube. Alternatively the inner tube can receive between the tapered or stepped ends an intermediate member such that each tapered or stepped end of the inner tube is adapted to overly a complementary tapered section of the intermediate member; the intermediate member being shaped so that in use the inner tube and the intermediate member serve to provide in combination an inner tube having a cross section of substantially uniform section along the axial length of the combination.</p>		

**FOR THE PURPOSES OF INFORMATION ONLY**

Codes used to identify States party to the PCT on the front pages of pamphlets publishing international applications under the PCT.

AM	Armenia	GB	United Kingdom	MW	Malawi
AT	Austria	GE	Georgia	MX	Mexico
AU	Australia	GN	Guinea	NE	Niger
BB	Barbados	GR	Greece	NL	Netherlands
BE	Belgium	HU	Hungary	NO	Norway
BF	Burkina Faso	IE	Ireland	NZ	New Zealand
BG	Bulgaria	IT	Italy	PL	Poland
BJ	Benin	JP	Japan	PT	Portugal
BR	Brazil	KE	Kenya	RO	Romania
BY	Belarus	KG	Kyrgyzstan	RU	Russian Federation
CA	Canada	KP	Democratic People's Republic of Korea	SD	Sudan
CF	Central African Republic	KR	Republic of Korea	SE	Sweden
CG	Congo	KZ	Kazakhstan	SG	Singapore
CH	Switzerland	LI	Liechtenstein	SI	Slovenia
CI	Côte d'Ivoire	LK	Sri Lanka	SK	Slovakia
CM	Cameroon	LR	Liberia	SN	Senegal
CN	China	LT	Lithuania	SZ	Swaziland
CS	Czechoslovakia	LU	Luxembourg	TD	Chad
CZ	Czech Republic	LV	Latvia	TG	Togo
DE	Germany	MC	Monaco	TJ	Tajikistan
DK	Denmark	MD	Republic of Moldova	TT	Trinidad and Tobago
EE	Estonia	MG	Madagascar	UA	Ukraine
ES	Spain	ML	Mali	UG	Uganda
FI	Finland	MN	Mongolia	US	United States of America
FR	France	MR	Mauritania	UZ	Uzbekistan
GA	Gabon			VN	Viet Nam

## INNER TUBE

### TECHNICAL FIELD

This invention relates to an inner tube for use with a pneumatic tyre particularly, though not exclusively, for a bicycle or a motor cycle.

### BACKGROUND ART

In the case of a conventional bicycle or motor cycle tyre the annular tyre carcass contains an annular inner tube. In the event of a puncture it is necessary to remove the wheel concerned and thereafter remove the tube from the tyre/tube combination. The inner tube can then be repaired to restore it to air tightness and any further repairs made to the tyre carcass. The repaired combination is then replaced on the wheel. With a bicycle the removal of a front wheel inner tube is not usually a problem. However the removal of a rear wheel inner tube involves the removal of any drive chain or shaft and, once the repair has been completed and the tyre/tube restored to the wheel, the wheel has to be restored to the bike with subsequent re-connection and re-tensioning of a drive chain or re-connection of a shaft and brake alignment.

A number of proposals have been made involving the provision of an inner tube which is not of annular shape (which can be described as 'endless') but rather is a straight tube (which can be described as 'non-continuous') located around a wheel rim within a tyre carcass until one end of the inner tube abuts the other. By way of example Canadian Application 2027905 in the name of Cheslock shows a non-continuous inflatable inner tube for vehicle tyre having two flat sealed ends intended for fitting and securing to one another when inflated so as to be held together by a mechanical device or system. One component of the device is described as preferably being in tension when the tube is inflated and at least one component is bonded to the tube. One component of the device is preferably an integral part of the sealed end and a valve stem is utilised as a component of the device. The tube ends are for example planar and one component is a thin flexible elastic tab vulcanised or attached to one tube end and which has an aperture through which a valve stem attached near the other tube end can be inserted.

## DISCLOSURE OF INVENTION

According to a first aspect of the present invention there is provided an inner tube for use with a pneumatic tyre casing having an internal volume with a specific mean length and a specific cross section; the inner tube being in the form of a thin flexible cylinder with closed ends; the ends being tapered or stepped so that when located within a pneumatic tyre as aforesaid the end of the inner tube are adapted to overlay one another to provide a scarfed joint between the ends, the resulting scarfed section having an overall cross section substantially similar to that of the remainder of a non-overlapping section of tube.

According to a first preferred version of the first aspect each end of the inner tube includes a plane section lying at an acute angle to a longitudinal axis of the inner tube, the plane sections, at least when the inner tube is in use, overlay and are juxtaposed with one another to provide the scarfed joint.

According to a second preferred version of the first aspect of the present invention each end of the inner tube is of conical or frusto conical shape and overlay one another to provide the scarfed joint as aforesaid.

According to a third preferred version of the first aspect or the first preferred version thereof the inner tube is adapted to receive between the tapered or stepped ends an intermediate member such that the each tapered or stepped end of the inner tube is adapted to overlay a complementary tapered section of the intermediate member; the intermediate member being shaped so that in use the inner tube and the intermediate member serve to provide in combination an inner tube having a cross section of substantially uniform section along the axial length of the combination.

According to a second aspect of the present invention there is provided a combination of a pneumatic tyre casing, an inner tube with a means for applying pneumatic inflation to the inner tube characterised by an inner tube according to the first aspect or any preferred version thereof.

According to a third aspect of the present invention there is provided a wheel

equipped with a combination according to the second aspect.

According to a fourth aspect of the present invention there is provided a vehicle having at least one ground engaging wheel according to the third aspect.

By providing an inner tube of cylindrical form, that is to say of finite axial length, with or without an intermediate member as aforesaid, the inner tube on a cycle or other pneumatically tyred vehicle wheel can be replaced without having to remove the wheel from its working position. This can be a particular benefit in relation to a rear wheel of a bicycle since apart from the tyre fitting operation there is no need to re-connect a drive chain or shaft. In addition by providing an inner tube with ends tapered, stepped or otherwise providing for a scarfed joint by overlapping the ends around a wheel and or with an intermediate member it becomes possible to provide a single size of inner tube which will fit a number of different sizes of tyre casing. To provide an end of progressively reducing size for overlapping the ends can be tapered with a pair of plane or other complementary faces for juxtaposition or can be of conical or frusto conical shape. Inflation of the inner tube when once it is in place will serve to cause the ends of the plastic inner tube to expand to fill the space available to them. If required any intervening space can be packed with inert material.

#### BRIEF DESCRIPTION OF DRAWINGS

Exemplary embodiments of the invention will now be described with reference to the accompanying drawing of a bicycle and components thereof of which:

Figure 1 is a side view;

Figure 2A shows an inner tube;

Figure 2B shows a part sectioned view of a tyre showing the end regions of the inner tube of Figure 2A when in use;

Figure 3 is a section on section III-III of Figure 2B with component parts in a first relative position;

Figure 4 shows the components of Figure 2B with component parts in a second relative position; and

Figure 5 shows an arrangement similar to that of Figure 2B but with an additional component.

## MODES FOR CARRYING OUT THE INVENTION

*Figure 1*

A bicycle 11 has a front wheel 12 and rear wheel 13 of known type. Typically the rear wheel 13 comprises a rim 14 mounted by spokes 15 on a central hub 16. The rear wheel 13 is driven by way of pedals P and drive chain C. The rear wheel 13 is equipped with a tyre 17 internally pressurised by means of an inner tube which can be inflated by way of valve 18. a conventional inner tube is in the form of an annulus with an internal diameter corresponding to the outside diameter of the wheel rim on which it is located. The mean circumferential length of such a conventional inner tube corresponds to the mean circumferential length L of the tyre that is to say a length approximately mid-way between the internal circumference L' of the tyre 17 (corresponding to bead circumference) and the outside circumference L" of the tyre (corresponding to the tread circumference).

*Figures 2A, 2B*

This shows an inner tube 40 in the form of a hollow cylinder with wall 41 and end walls 42, 43 which are tapered and effectively parallel to one another. Overall length M of the inner tube 40 is longer than the mean length L of a conventional inner tube described earlier by an amount corresponding to length N of one, but not both, of tapered end walls 42, 43. Figure 2B shows the inner tube 40 when located in a working position within tyre 17. End sections 42, 43 overlap one another so that in combination they provide a scarf joint with a similar radial thickness to the remainder of the inner tube. Consequently the inner tube 40 provides support for the tyre 17 over virtually the entire internal length of the tyre.

In alternative versions of an inner tube according to the present invention the end walls can provide for the scarfed overlap arrangement such as by a stepped end sections. By providing tapered end walls 42, 43 or stepped or other shapes providing for a scarfed type of overlap the inner tube can be used in tyres of different size, that is to say which vary in mean circumferential length. One advantage is that a limited number of sizes of inner tubes according to the present invention can be stocked for use with a greater number of tyre casings.

Figure 5 shows an arrangement of components similar to that of Figure 3B where an alternative or additional means is provided to increase the effective length of the inner tube 40 means of an intermediate member 51 lying between the end walls 42, 43 so that the end walls 42, 43 overlap, respectively, ends face 52, 53 of the member 51 rather than themselves to provide the scarfed joint. The intermediate member 51 can either be a separately inflatable flexible member or a solid member to provide an inner tube combination where the inner tube and intermediate member are of substantially constant cross section throughout their axial length.

In the case of the embodiment shown in Figures 2A, 2B the ends 42, 43 of the inner tube 40 can be secured to one another by an adhesive. In addition it is envisaged that in the event the inner tube would not, once inflated, wholly fill the internal volume of a given tyre casing then packing material can be added to ensure substantially uniform interior support for the tyre carcass.

*Figures 3, 4*

In the event of tyre 17 on rear wheel 13 (Figure 1) sustaining a puncture with a conventional inner tube it would be necessary to gain access to the inner tube by first releasing the chain C and removing the rear wheel 13 and then extracting the inner tube. However by utilising the present invention it becomes unnecessary to remove the chain C or the wheel 13. Instead the bicycle 11 is positioned so that the wheel 13 is readily accessible and the tyre 17, which owing to the puncture is no longer inflated or supported by the inner tube, is compressed so as to displace bead 17" towards bead 17' to expose the inner face of rim 14 as shown in Figure 4. Inner tube 30 is then fed onto the rim 14 and beneath the bead 17". Because of the cylindrical form of the inner tube 30 it is readily fed onto the rim with the wheel 13 still in place and with its drive chain C still connected. Once the inner tube 30 has been fully fed into place the inner tube 30 is inflated by way of air valve a causing the tyre 17 to be fully supported with rims 17', 17" seated symmetrically on the rim 14. The end walls 32, 33 of inner tube 30, when located within the tyre casing 17 and with the inner tube 30 correctly inflated, abut one another so that for practical purposes the casing 17 is supported virtually throughout its interior length.

## INDUSTRIAL APPLICABILITY

The present invention provides for an inner tube, for use with a pneumatic tyre casing, of simpler construction and capable of being more readily replaced in use than a conventional inner tube. By providing an inner tube with ends adapted to overlap either directly or on an intermediate member to provide for a scarf joint it becomes possible to use a given size of inner tube for more than one size of tyre casing.

The exemplary embodiments describe an inner tube having ends which include a pair of overlapping faces to provide a scarfed joint. However such a joint can also be provided by having conical or frusto conical ends to the tyres. For many applications such ends will provide acceptable performance even though the overlapping ends may not wholly conform in cross section to the remaining cross section of the tyre lying between the ends.

As the inner tube is of inherently plastic material when inflated the overlapping ends tend to expand to fill the space available to them.

For a given tyre casing more than one inner tube of the proposed type can be used where each inner tube is shorter in length than the circumference of the tyre. Where several inner tubes are used to substantially fill the interior of a given tyre each can be individually inflated to provide for the tyre to be supported substantially uniformly around its internal circumference.

The inner tube and inner tube tyre of the present invention are particularly concerned for use with bicycle and motor cycles. However similar devices could be used for cars and other equipment having ground engaging wheels utilising inflatable inner tubes and tyres. An inner tube of the present invention could also be used, typically in an emergency, to provide a temporary repair for a deflated tyre until a service location can be reached.

## CLAIMS

- 1 An inner tube for use with a pneumatic tyre casing having an internal volume with a specific mean length and a specific cross section; the inner tube being in the form of a thin flexible cylinder with closed ends; the ends being tapered or stepped so that when located within a pneumatic tyre as aforesaid the ends of the inner tube are adapted to overlay one another to provide a scarfed joint between the ends, the overlapping section having a cross section substantially similar to that of the remainder of a non-overlapping section of tube.
- 2 An inner tube as claimed in Claim 1 wherein each end of the inner tube includes a plane section lying at an acute angle to a longitudinal axis of the inner tube, the plane sections, at least when the inner tube is in use, overlay and are juxtaposed with one another to provide the scarfed joint as aforesaid.
- 3 An inner tube as claimed in Claim 1 wherein each end of the inner tube is of conical or frusto conical shape and overlay one another to provide the scarfed joint as aforesaid.
- 4 An inner tube as claimed in Claim 1 or Claim 2 adapted to receive between the tapered or stepped ends an intermediate member such that the each tapered or stepped end of the inner tube is adapted to overlay a complementary tapered section of the intermediate member; the intermediate member being shaped so that in use the inner tube and the intermediate member serve to provide in combination an inner tube having a cross section of substantially uniform section along the axial length of the combination.
- 5 A combination of a pneumatic tyre casing, an inner tube with a means for applying pneumatic inflation to the inner tube characterised by an inner tube as claimed in Claim 1, Claim 2 or Claim 3 or an inner tube/intermediate member combination as claimed in Claim 4.

- 6 A wheel equipped with a combination of a tyre casing and an inner tube as claimed in Claim 5.
- 7 A vehicle having at least one ground engaging wheel as claimed in Claim 6.

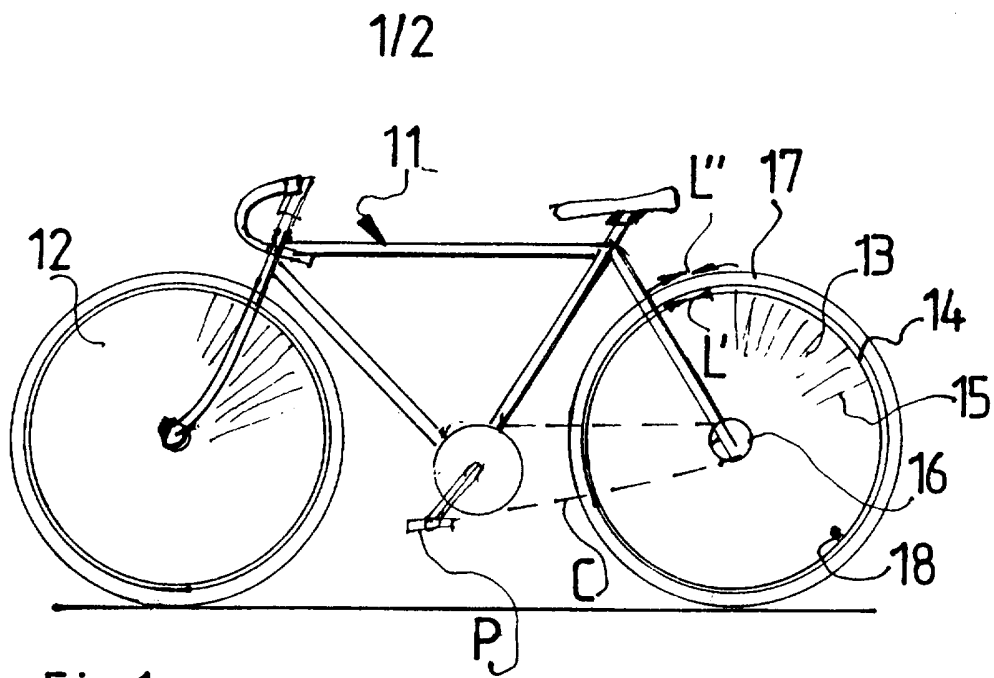

Fig 1

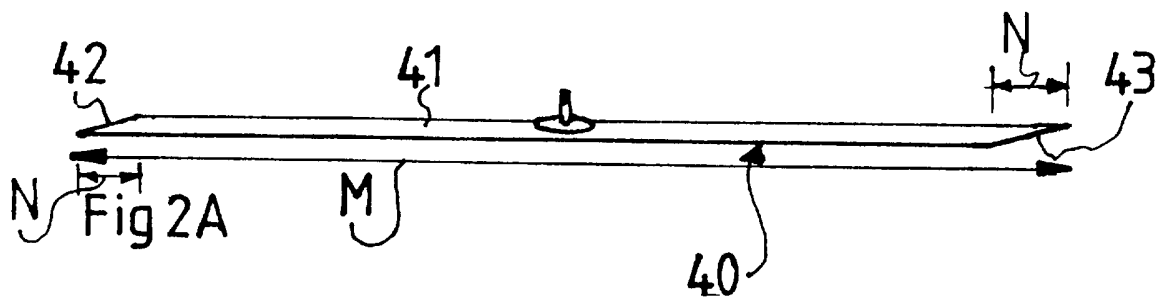

Fig 2A

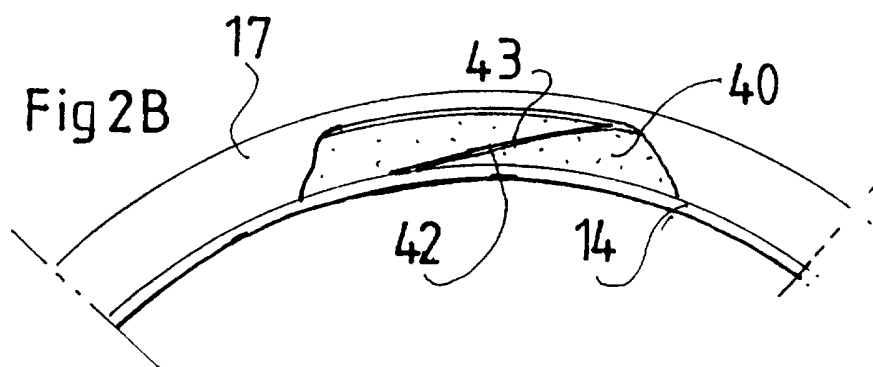

Fig 2B

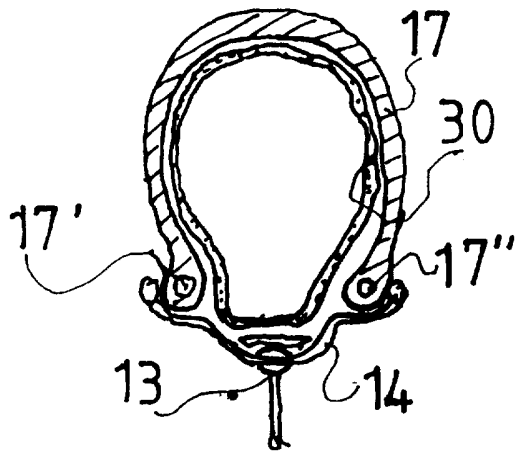

Fig 3

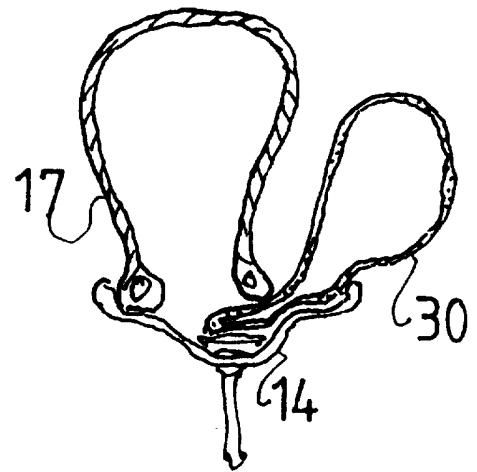

Fig 4

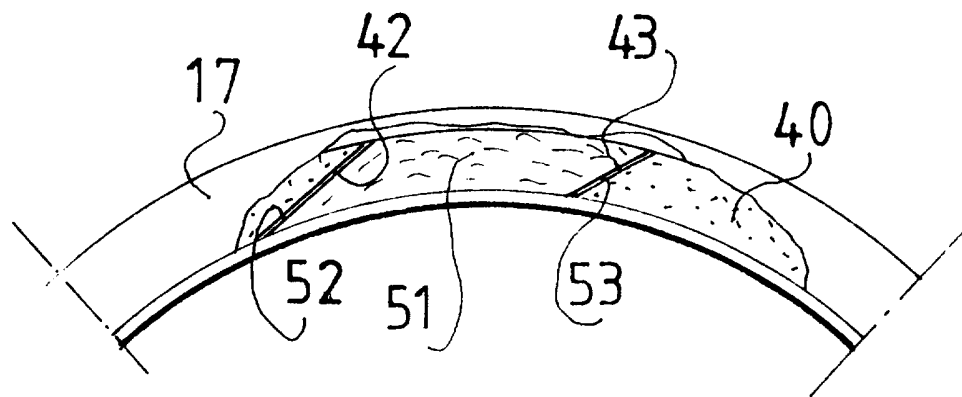

Fig 5

# INTERNATIONAL SEARCH REPORT

International Application No  
PCT/GB 97/00079

<b>A. CLASSIFICATION OF SUBJECT MATTER</b> IPC 6 B60C5/10		
According to International Patent Classification (IPC) or to both national classification and IPC		
<b>B. FIELDS SEARCHED</b> Minimum documentation searched (classification system followed by classification symbols) IPC 6 B60C		
Documentation searched other than minimum documentation to the extent that such documents are included in the fields searched		
Electronic data base consulted during the international search (name of data base and, where practical, search terms used)		
<b>C. DOCUMENTS CONSIDERED TO BE RELEVANT</b>		
Category *	Citation of document, with indication, where appropriate, of the relevant passages	Relevant to claim No.
X	NL 7 711 463 A (E.A. VELDHUIS) 23 April 1979 see claims 1-3; figures 1,2 ---	1-7
X	DE 92 02 345 U (G. BEHRENS ET AL.) 16 April 1992 see the whole document ---	1-7
X	FR 1 105 267 A (A.A. MANARA) 29 November 1955 see the whole document ---	1-7
X	DE 28 32 546 A (METZELER KAUSCHUK AG) 7 February 1980 see figure 4 ---	1-7
A	DE 732 710 A (R. RÜDIGER) 10 March 1943 see the whole document ---	1
-/--		
<input checked="" type="checkbox"/> Further documents are listed in the continuation of box C.		
<input checked="" type="checkbox"/> Patent family members are listed in annex.		
* Special categories of cited documents :		
*A* document defining the general state of the art which is not considered to be of particular relevance	*T* later document published after the international filing date or priority date and not in conflict with the application but cited to understand the principle or theory underlying the invention	
*E* earlier document but published on or after the international filing date	*X* document of particular relevance; the claimed invention cannot be considered novel or cannot be considered to involve an inventive step when the document is taken alone	
*L* document which may throw doubts on priority claim(s) or which is cited to establish the publication date of another citation or other special reason (as specified)	*Y* document of particular relevance; the claimed invention cannot be considered to involve an inventive step when the document is combined with one or more other such documents, such combination being obvious to a person skilled in the art.	
*O* document referring to an oral disclosure, use, exhibition or other means	*&* document member of the same patent family	
*P* document published prior to the international filing date but later than the priority date claimed		
Date of the actual completion of the international search  <div style="text-align: center; font-weight: bold;">9 May 1997</div>	Date of mailing of the international search report  <div style="text-align: center; font-weight: bold;">26.05.1997</div>	
Name and mailing address of the ISA European Patent Office, P.B. 5818 Patentlaan 2 NL - 2280 HV Rijswijk Tel. (+31-70) 340-2040, Tx. 31 651 epo nl, Fax: (+31-70) 340-3016	Authorized officer  <div style="text-align: center; font-weight: bold;">Reedijk, A</div>	

# INTERNATIONAL SEARCH REPORT

Inter   nal Application No  
PCT/GB 97/00079

C.(Continuation) DOCUMENTS CONSIDERED TO BE RELEVANT

Category *	Citation of document, with indication, where appropriate, of the relevant passages	Relevant to claim No.
A	GB 645 456 A (D.J. CHAPPELL ET AL.) 1 November 1950 see figure 3 <p style="text-align: center;">---</p>	1-7
A	FR 950 437 A (R. TCHAPIAN) 27 September 1949 see the whole document <p style="text-align: center;">-----</p>	4,5

1

# INTERNATIONAL SEARCH REPORT

Information on patent family members

Internal Application No  
PCT/GB 97/00079

Patent document cited in search report	Publication date	Patent family member(s)	Publication date
NL 7711463 A	23-04-79	NONE	
DE 9202345 U	16-04-92	NONE	
FR 1105267 A	29-11-55	NONE	
DE 2832546 A	07-02-80	NONE	
DE 732710 A		NONE	
GB 645456 A		NONE	
FR 950437 A	26-09-49	NONE	