



US 20040090795A1

(19) **United States**

(12) **Patent Application Publication**
Kim

(10) **Pub. No.: US 2004/0090795 A1**

(43) **Pub. Date: May 13, 2004**

(54) **LIGHTWEIGHT, ENERGY-EFFICIENT,
DETACHABLE COMPUTER LIGHT**

Publication Classification

(76) Inventor: **Darren C. Kim**, Oakland, CA (US)

(51) **Int. Cl.⁷ F21V 7/04**

(52) **U.S. Cl. 362/555**

Correspondence Address:
Frederick D. Kim
1430 Newfoundland Dr.
Sunnyvale, CA 94087 (US)

(57) **ABSTRACT**

(21) Appl. No.: **10/702,382**

(22) Filed: **Nov. 4, 2003**

Related U.S. Application Data

(63) Continuation of application No. 09/847,195, filed on May 1, 2001, now Pat. No. 6,680,844.

(60) Provisional application No. 60/207,446, filed on May 30, 2000.

A computer light for illuminating the computer keyboard or other items in low light environments includes a super bright white LED and a USB plug that enables it to be powered from USB connection ports. The computer light has an elongated neck that is flexible enough to allow the light head to be positioned with ease but stiff enough to allow the light head to assume a fixed position relative to the computer keyboard or other items when it is not being manipulated. The computer light is especially useful for users of portable computers because it is lightweight and energy-efficient, and may be stored in a compact manner.

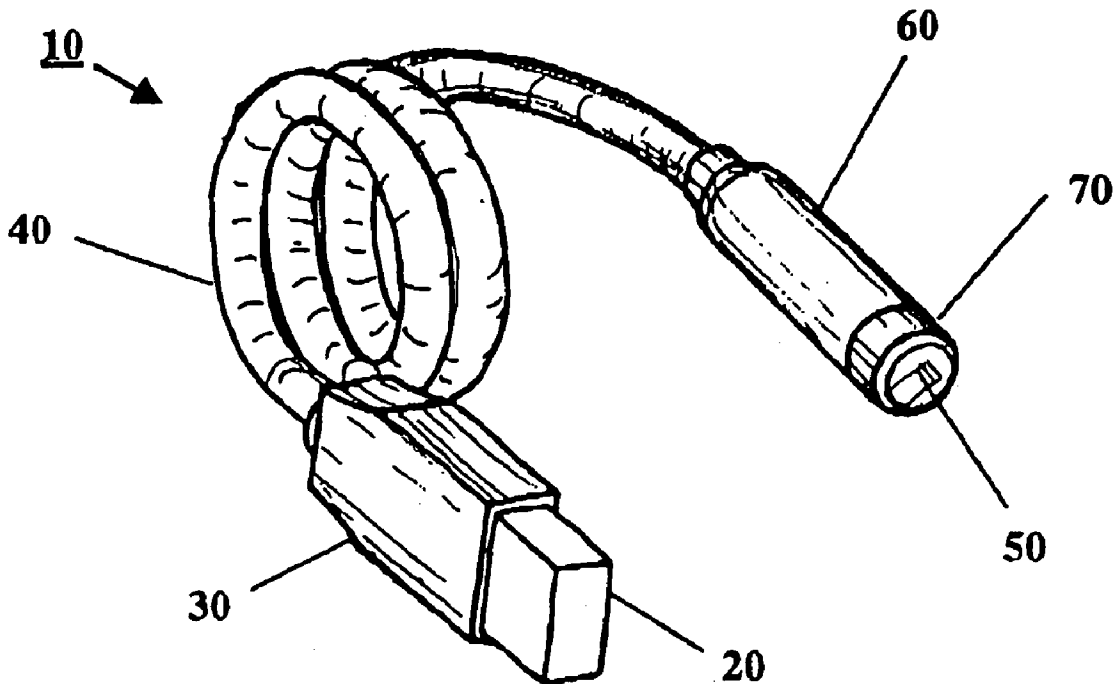

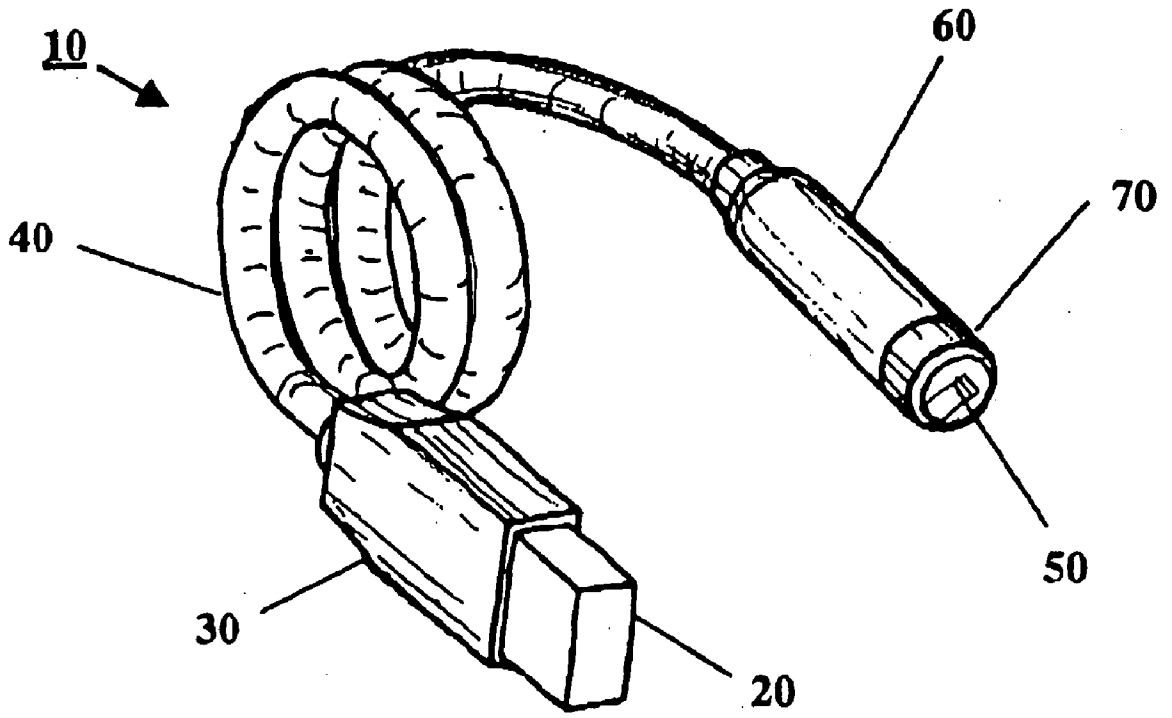

Figure 1

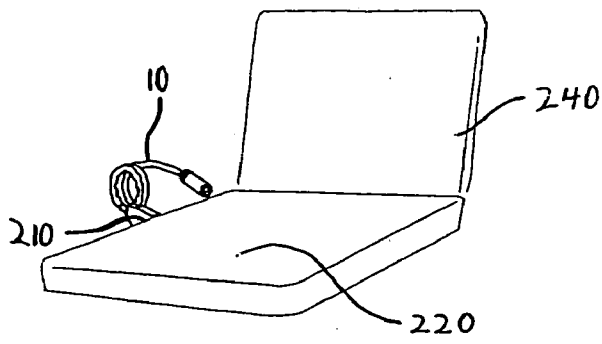

FIGURE 2

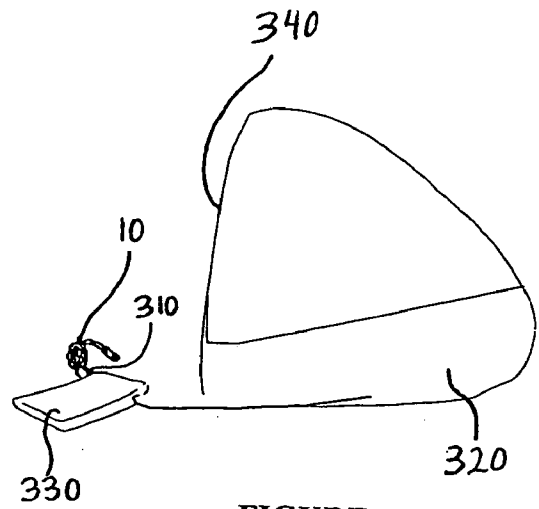

FIGURE 3

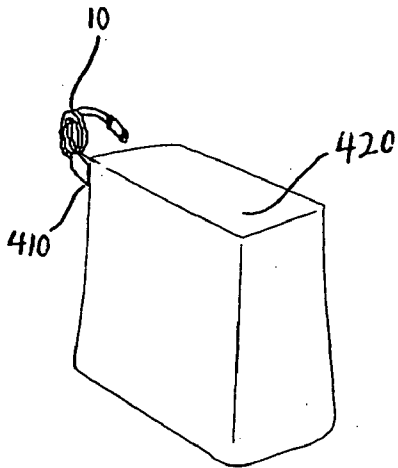

FIGURE 4

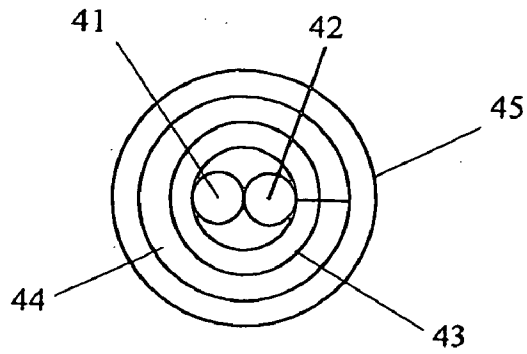

FIGURE 5A

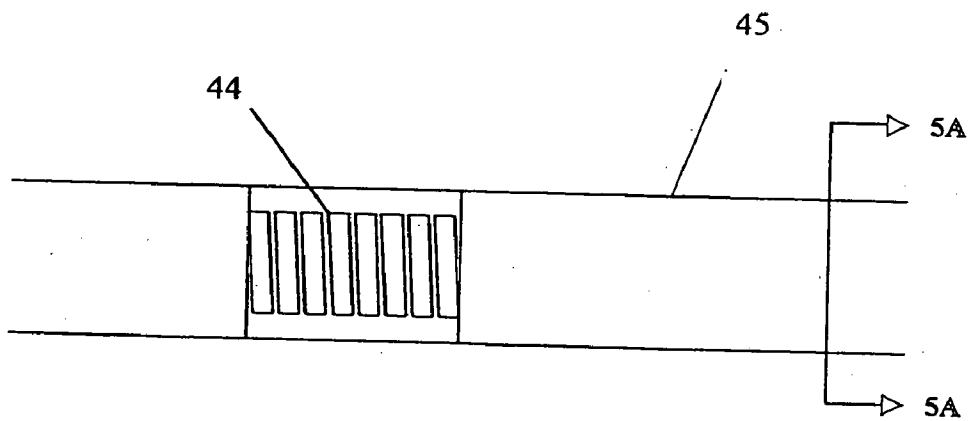

FIGURE 5B

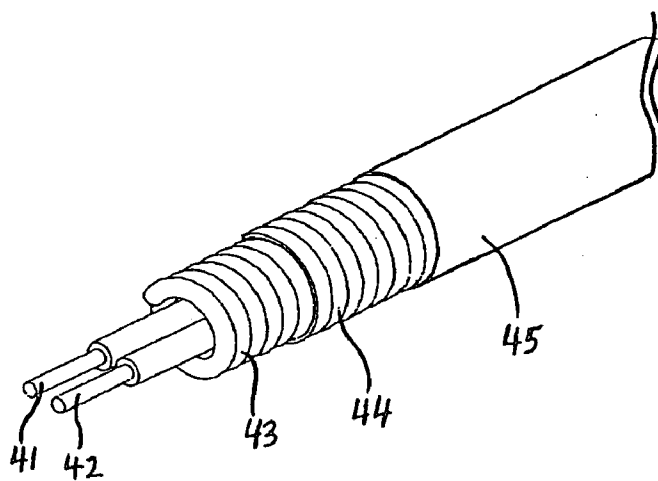

Figure 5C

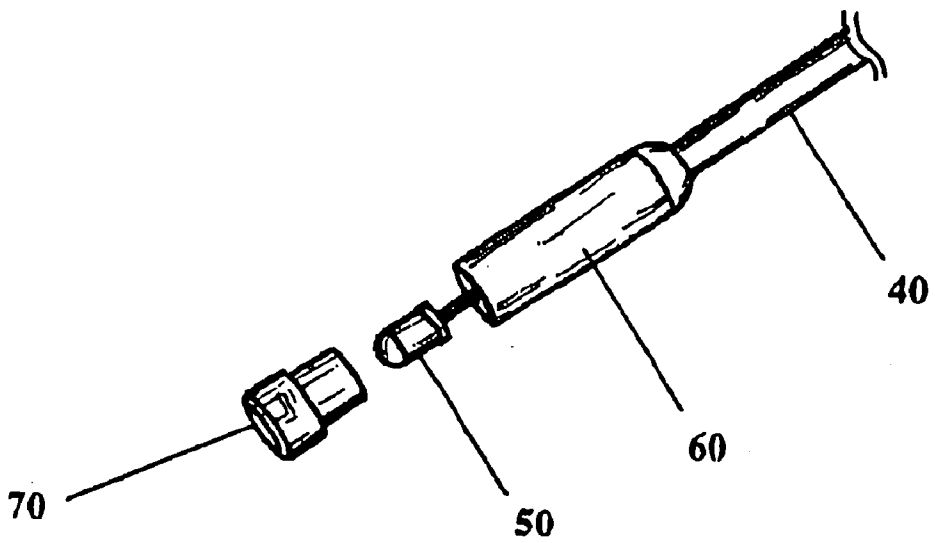

FIGURE 6A

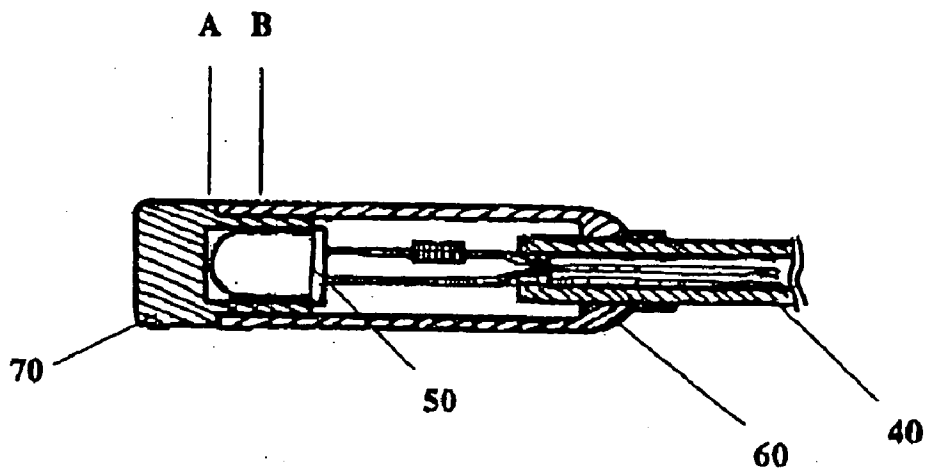

FIGURE 6B

Fore ← → Aft

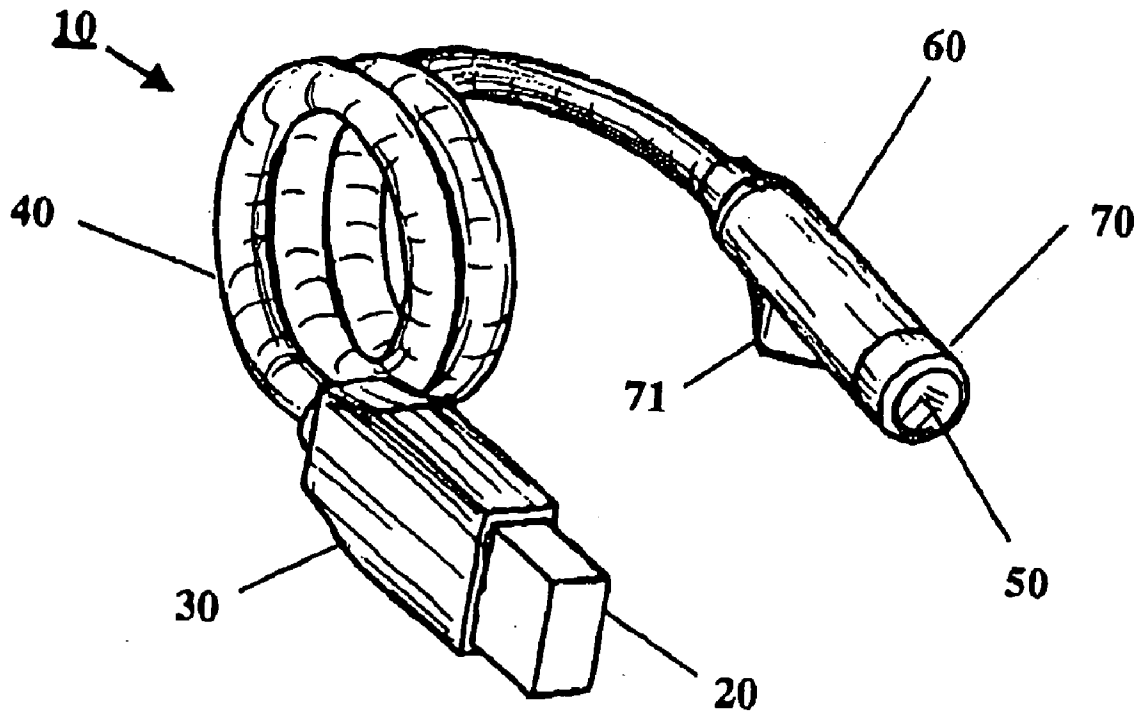

FIGURE 7

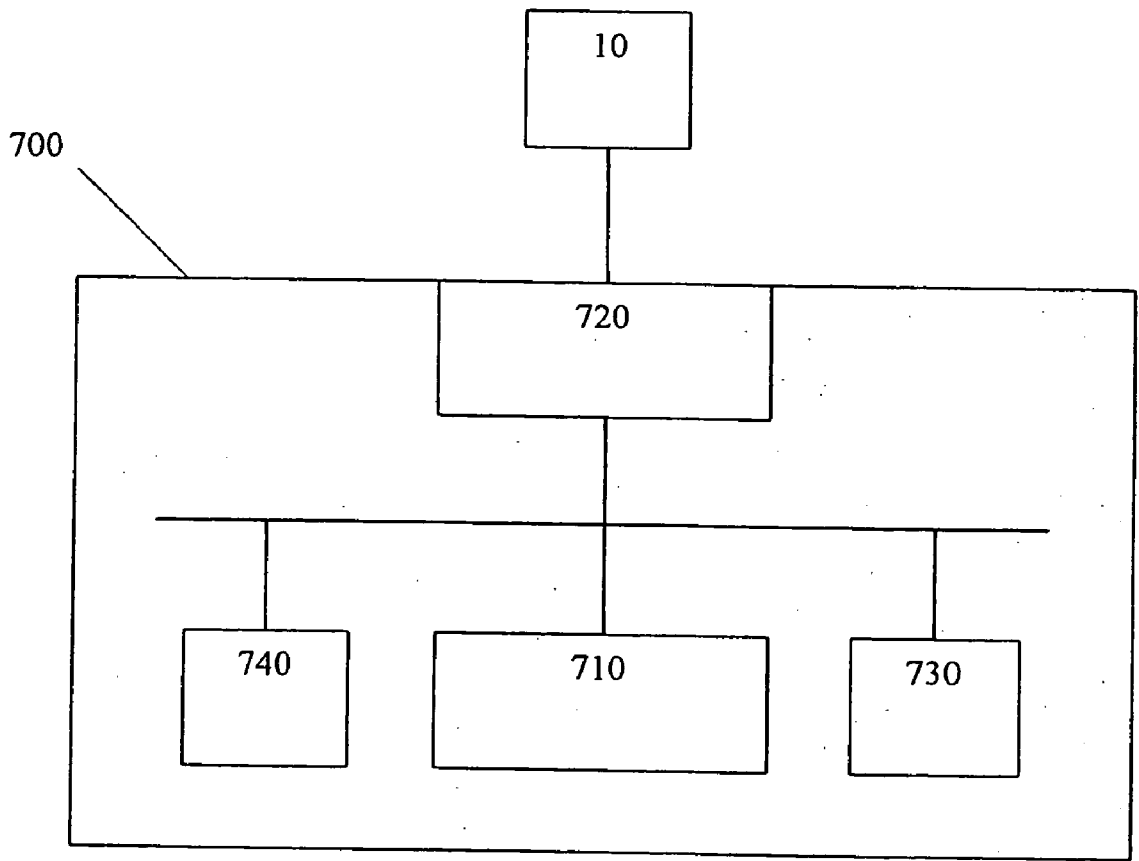

FIGURE 8

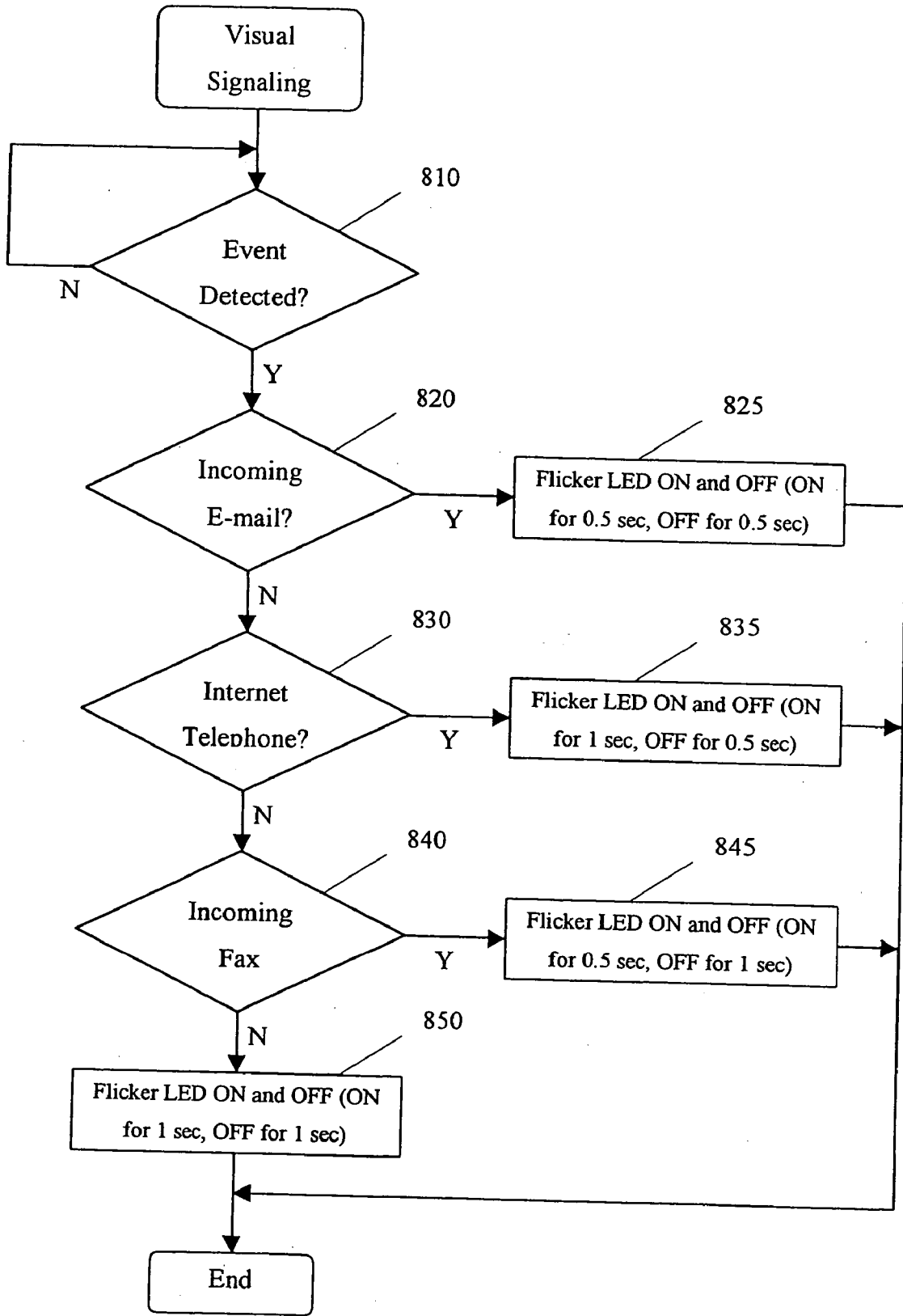

FIGURE 9

LIGHTWEIGHT, ENERGY-EFFICIENT, DETACHABLE COMPUTER LIGHT

RELATED APPLICATION

[0001] This application claims the benefit of Provisional Patent Application No. 60/207,446, filed May 30, 2000. The entire contents of this provisional patent application are incorporated by reference herein.

BACKGROUND OF THE INVENTION

[0002] 1. Field of the Invention

[0003] The invention relates generally to a computer light, and more particularly to a portable energy-efficient light that is compatible with a computer port such as the Universal Serial Bus (USB) port or the IEEE1394 (firewire) port.

[0004] 2. Description of the Related Art

[0005] As computer use has increased over the years, computer use in low light environments has increased as well. In low light environments, the user is able to view the screen but oftentimes is unable to see the computer keyboard or view paper notes such as presentation notes or slides. This is inconvenient even for skilled typists because some keys (e.g., arrow, function, and delete keys) are located on the outer edges of the keyboard and thus are hard to locate by feel. At times, the user needs to look at the keyboard and locate the desired key before pressing it, but when there is little or no light for illuminating the keyboard, the user often resorts to guessing and presses the wrong key. In addition oftentimes, when a user needs to remove or insert cables into the computer, there is little light in the back of the computer appliance.

[0006] Many portable light devices are available for the computer user, but these devices require their own power source and are convenient only for use in conjunction with desktop computers. These devices are simply too bulky to be carried around and used in conjunction with laptop computers. The weight that the portable light device and its power source adds to the weight of the laptop computer and the laptop computer's power source is also a limiting factor. For these and other reasons, portable light devices, although useful, have not yet become popular with laptop computer users and handy for desktop computer users.

SUMMARY OF THE INVENTION

[0007] The invention provides a computer light that illuminates the computer keyboard or other items, such as a document that the computer user is working on, in low light environments. The computer light is lightweight and has a plug that is connectable to a computer port to draw power from the computer's power source. As a result, users of laptop computers may pack and carry around this device with their laptop computers without adding too much extra weight. The computer light is also energy-efficient so that it does not cause an unnecessary power drain on the power supply of the laptop computer. Furthermore, the computer light has an elongated neck that is flexible enough to allow the light head to be positioned with ease but stiff enough to allow the light head to assume a fixed position relative to the computer keyboard or other items when it is not being manipulated.

BRIEF DESCRIPTION OF THE DRAWINGS

[0008] FIG. 1 illustrates a computer light according to an embodiment of the invention;

[0009] FIG. 2 illustrates the computer light connected to a port provided on a laptop computer;

[0010] FIG. 3 illustrates the computer light connected to a port provided on a computer keyboard;

[0011] FIG. 4 illustrates the computer light connected to a port provided on a main console of a desktop computer;

[0012] FIG. 5A is a cross-sectional view of a gooseneck cable of the computer light;

[0013] FIG. 5B is a plan view of the gooseneck cable having a cut-away portion;

[0014] FIG. 5C is a perspective view of a cut-away section of the gooseneck cable;

[0015] FIG. 6A is an exploded perspective view of the LED head assembly;

[0016] FIG. 6B is a cross-sectional view of the LED head assembly;

[0017] FIG. 7 illustrates the computer light equipped with an ON-OFF switch;

[0018] FIG. 8 is a schematic diagram illustrating the components that control the computer light to visually signal an event to the computer user; and

[0019] FIG. 9 is a flow diagram illustrating the program steps executed by a processor to visually signal an event to the computer user.

[0020] The accompanying drawings, which are incorporated in and constitutes a part of the specification, illustrate presently preferred embodiments of the invention, and together with the general description given above and the detailed description of the preferred embodiments given below, serve to explain the principles of the invention.

DETAILED DESCRIPTION OF THE PREFERRED EMBODIMENTS

[0021] The preferred embodiment described below relates to a computer light that is configured to be used with a USB port on a computer, but the invention need not be limited thereto. For example, it is contemplated that a computer light embodying the features of the invention may be configured for use with other computer ports, including but not limited to, the IEEE1394 (firewire) port.

[0022] FIG. 1 illustrates a computer light according to an embodiment of the invention. The computer light or lamp 10 has a USB plug 20 to be connected to power and ground leads of a USB connector on a computer (see FIGS. 2 and 4) or a computer keyboard (see FIG. 3).

[0023] Functionally, the computer light 10 is a USB-slave device. A USB slave device is peripheral device that is controlled by any USB master device using a communication protocol known as the USB protocol. Other examples of a USB slave device include scanners, microphones, speakers, and game control devices. USB ports have become increasingly popular in recent years because of its high data rates, industry standard support and compact port design.

[0024] An over-molded plastic jacket **30** is formed partially over the USB plug **20**. The plastic jacket **30** serves as a handle used during the insertion of the USB plug **20** into a corresponding USB connection port on a computer and a stop limit to prevent the USB plug **20** from being inserted too far into the corresponding USB connection port.

[0025] The computer light further includes a gooseneck cable **40** and a light emitting diode (LED) **50**. As shown in FIG. 5A, the gooseneck cable **40** has a pair of insulated copper wires **41**, **42** extending along its center portion to electrically couple the USB plug **20** to the LED **50**. The gooseneck cable **40** is flexible enough to allow manual positioning of the LED **50** but stiff enough to allow the LED **50** to assume a fixed position relative to the computer keyboard or other items when it is not being manipulated. Also, when the computer light is not in use, the gooseneck cable **40** permits it to be coiled into a compact position.

[0026] The rigidity or stiffness in the gooseneck cable **40** is introduced by a pair of tubings **43**, **44**, the cross-sections of which are shown in FIG. 5A. A plastic cover **45** is provided for decorative purposes. Each of the tubings **43**, **44** is made of metal wire and is formed by winding the metal wire into a tight spiral as shown in the cut-away view in FIGS. 5B and 5C. The outer radius of the spirals of the inner tubing **43** is formed to be substantially equal to the inner radius of the spirals of the outer tubing **44**. The static friction force between the inner and outer tubings **43**, **44** tends to keep the gooseneck cable **40** in a fixed position when no forces are being applied.

[0027] In the preferred embodiment, the winding direction of the spirals of the inner tubing **43** is the same as the winding direction of the spirals of the outer tubing **44**. In alternative embodiments, the winding directions may be different. Further, the invention is not limited to any one way of introducing rigidity or stiffness to the gooseneck cable **40**. Alternative ways are known to those of ordinary skill in the art and the invention is intended to cover all such variations.

[0028] The length of the gooseneck cable **40** is preferably about 16-18 inches. Other lengths of the gooseneck cable **40** may be used in accordance with the invention, but based on predictable uses of the computer light, especially with laptop computers, it was determined that the length of 16-18 inches would be convenient to the user. This length makes the computer light **10** easy to handle and allows the LED **50** to be positioned over the top, side, next to the base unit, etc.

[0029] The LED **50** produces a super bright white light and is positioned with the gooseneck cable **40** to provide illumination for the computer keyboard, display, side, etc. When the computer light **10** is inserted into the USB connection port on the host computer or host keyboard, power from the computer's power supply is supplied to the LED **50** by way of the USB plug **20** and the wires in the gooseneck cable.

[0030] In the exemplary embodiment, the LED **50** requires 3.6-4.0 volts and draws approximately 0.020-0.030 milliamperes. As such, the LED **50** consumes around 0.1 watts when connected to the computer's power supply. Since the computer provides a 5-volt source, the voltage is stepped down to 3.6 volts before being supplied to the LED **50**. Even when it is used constantly and remains ON, the LED **50** decreases the battery life of a laptop computer by only 1 to

3%. One example of an LED that has the above characteristics is an LED manufactured by Nichia. Another advantage of the LED is its very high life expectation. As a result, unlike light bulbs, which need to be replaced fairly often, with an LED, there is little or no need for replacement.

[0031] Because the LED **50** draws its power from the computer through the USB connection port, the computer light **10** does not need a battery pack as a power source. Consequently, the lamp design is greatly simplified, has less parts and minimizes weight. In the exemplary embodiment, the total weight of the computer light **10** is less than 3 ounces. In addition, the computer light **10** is very durable and shockproof. Unlike lamps that use light bulbs, there are no parts that can break easily.

[0032] As further illustrated in FIG. 1, the LED **50** is encased by aluminum cylindrical housing **60** and a plastic clear lens **70**. One end of the cylindrical housing **60** is fitted over the gooseneck cable **40** so that the cylindrical housing surrounds the LED **50** and the lens **70** is press fitted to the other end of the cylindrical housing **60** to encapsulate the LED **50** inside the cylindrical housing **60**.

[0033] The details of the LED head assembly is illustrated in FIGS. 6A and 6B. FIG. 6A is an exploded perspective view and FIG. 6B is a cross-sectional view in the assembled state. Line A in FIG. 6B represents the fore-aft position of the rear plane of the lens **70** and Line B in FIG. 6B represents the fore-aft position of the light point source of the LED. In the preferred embodiment, Line B is behind Line A, as shown in FIG. 6B. The position of the LED in the preferred embodiment provide useful light without producing the harsh glare that can be distracting to the user.

[0034] The plastic clear lens **70** alters light beam characteristics of light emitted by the LED **50**, e.g., color, amount of dispersal, etc. The surface finish of the lens **70** can be changed to provide different light quality as well as provide a soft glow that can be very pleasing to the user.

[0035] Alternatively, the plastic clear lens **70** may include a silvered reflector that is positioned in front of the LED **50**. The light from the LED **50** spans a small cone angle and the silvered reflector reflects the light into desirable position, spread, characteristic or intensity.

[0036] In addition, the plastic clear lens **70** may include physical or digital mask to alter the light beam to convey information to the user such as temperature reading, time, etc. For example, a lensing element plus a miniature liquid crystal display can be used together to produce a light beam that when reflected against a wall can provide a clock feature to the user. Also, a multicolor LED can be used to convey information to the user through the change in the color.

[0037] FIG. 2 illustrates the computer light **10** connected to a USB connection port **210** provided on a main console **220** of a laptop computer. A keyboard (not shown) of the laptop computer is formed integrally on the upper surface of the main console **220** of the laptop computer, and a display **240** is attached in a hinged manner to the main console **220** of the laptop computer.

[0038] FIG. 3 illustrates the computer light **10** connected to a USB connection port **310** provided on a keyboard **330** of a desktop computer. The keyboard **330** is electrically connected to a main console **320** of the desktop computer

through an electrical cord and plug but is physically separate from the main console **320**. A display **340** of the desktop computer is, however, is formed integrally on the front face of the desktop computer. In this embodiment, power is supplied from the power supply housed in the main console to the LED **50** through the keyboard **330**.

[0039] FIG. 4 illustrates the computer light **10** connected to a USB connection port **410** provided on a main console **420** of a desktop computer. In this embodiment, both the computer keyboard **430** and the computer display **440** are physically separate from the main console **420** and electrically connected to the main console **420** through their respective electrical cords and plugs.

[0040] In the three embodiments shown in FIGS. 2-4, the main console includes a processor, associated memory, and a power source. The power source is typically a DC power source and is configured to supply power to externally connected devices through connection ports, e.g., to USB slave devices through USB connection ports.

[0041] FIG. 7 illustrates the computer light **10** equipped with an ON-OFF switch **71**. When the switch **71** is in an ON position, a closed circuit is formed and power from the computer's power supply is allowed to be supplied to the LED **50**. When the switch **71** is in an OFF position, an open circuit is formed and power from the computer's power supply is cut off from the LED **50**. The computer light **10** may be provided with a female USB connection port (not shown) to allow a different USB slave device to be connected to the USB connector port of the host computer thereby and be operable when the switch **71** of the computer light **10** is turned off.

[0042] FIG. 8 is a schematic diagram of a main console **700** of a computer, illustrating the components that control the computer light **10** to visually signal an event to the computer user. The components include a programmed microprocessor **710** and associated memory **730** for sensing or detecting an event, e.g., an incoming email, an internet telephone call, an incoming fax that is electronically delivered to the computer, or a level of network traffic, and a USB controller circuit **720**, under the control of the programmed microprocessor **710**, for alternatively supplying power from the power source **740** to the connected computer light **10** and cutting off power from the power source **740** to the connected computer light **10**, to cause the computer light **10** to flicker ON and OFF for a preprogrammed period of time, e.g., 5 seconds, which should be long enough to grab the user's attention. The time period for flicker may be controlled by the user by reconfiguring the email program.

[0043] The computer program for executing the visual signaling is illustrated as a flow diagram in FIG. 9. Step **810** is continuously executed by the programmed microprocessor **710** to see if an event, which may be an incoming e-mail, incoming telephone call via internet telephony, an incoming fax message, or any event that the computer recognizes, is sensed or detected. If it is, in Steps **820**, **830** and **840**, a type of event is distinguished. If the event is an incoming e-mail, the USB controller circuit **720** is controlled to cycle the LED **50** ON and OFF for equal time periods, e.g., ON for 0.5 second and OFF for 0.5 second (Step **825**). If the event is an internet telephone call, the USB controller circuit **720** is controlled to cycle the LED **50** ON and OFF with a longer ON period than OFF period, e.g., ON for 1 second and OFF

for 0.5 second (Step **835**). If the event is an incoming facsimile, the USB controller circuit **720** is controlled to cycle the LED **50** ON and OFF with a shorter ON period than OFF period, e.g., ON for 0.5 second and OFF for 1 second (Step **845**). For all other events, the USB controller circuit **720** is controlled to cycle the LED **50** ON for 1 second and OFF for 1 second (Step **850**).

[0044] In addition, the different information can be conveyed through the use of color through the use of a multi-color LED.

[0045] While particular embodiments according to the invention have been illustrated and described above, it will be clear that the invention can take a variety of forms and embodiments within the scope of the appended claims.

1. A computer light device comprising:

an LED;

a flexible neck connected at a first end to the LED;

a plug connectable to a power source through a computer port, the plug being connected to the flexible neck to supply power to the LED through the flexible neck.

2. The computer light device according to claim 1, wherein the LED consumes about 0.1 watts when connected to the power source.

3. The computer light device according to claim 1, wherein the flexible neck includes inner and outer tubings in intimate contact with each other.

4. The computer light device according to claim 3, wherein the flexible neck includes a pair of wires extending along the center of the inner and outer tubings and electrically coupling the plug and the LED.

5. The computer light device according to claim 4, wherein the flexible neck has a length of about 16-18 inches, and the flexible neck is sufficiently rigid to suspend the LED at a fixed position.

6. The computer light device according to claim 4, wherein the inner and outer tubings are comprised of a plurality of windings.

7. The computer light device according to claim 1, further comprising a cylindrical housing and a lens, wherein one end of the cylindrical housing is fitted over the flexible neck so that the cylindrical housing encompasses the LED and the lens is fitted to another end of the cylindrical housing.

8. The computer light device according to claim 7, wherein the lens comprises a plastic clear lens that alters light beam characteristics of light emitted by the LED.

9. The computer light device according to claim 8, wherein the plug is a USB port compatible plug.

10. The computer light device according to claim 1, wherein the plug is a USB port compatible plug.

11. A computing device comprising:

a main console having a processor, associated memory, and a power source;

an input device coupled to the main console;

an output device coupled to the main console; and

an LED device electrically connected to the power source, the LED device including an LED head and a flexible neck.

12. The computing device according to claim 11, wherein the main console includes a USB connector and the LED device is electrically connected to the power source through the USB connector.

13. The computing device according to claim 12, wherein the LED device includes a USB plug that is engaged with the USB connector.

14. The computing device according to claim 11, wherein the input device includes a USB connector and the LED device is electrically connected to the power source through the USB connector.

15. The computing device according to claim 14, wherein the LED device includes a USB plug that is engaged with the USB connector.

16. The computing device according to claim 11, wherein the LED device includes a switch.

17. The computing device according to claim 11, wherein the flexible neck includes inner and outer tubings in intimate contact with each other.

18. The computing device according to claim 17, wherein the flexible neck of the LED device has a length of about 16-18 inches and is sufficiently rigid to suspend the LED head of the LED device at a fixed position relative to the main console.

19. In a computer having a processing unit, an input device coupled to the processing unit, an output device coupled to the processing unit, and an LED device coupled to the processing unit through a computer port, a method of visually signaling a user of the computer, said method comprising the steps of:

sensing an event; and

in response to the sensing of the event, powering ON the LED device to signal the user of the computer.

20. The method according to claim 19, wherein the step of sensing includes the step of sensing an incoming e-mail message.

21. The method according to claim 19, wherein the step of sensing includes the step of sensing an incoming internet telephone call.

22. The method according to claim 19, wherein the step of sensing includes the step of sensing an incoming facsimile.

23. The method according to claim 19, wherein the step of sensing includes the step of sensing a level of network traffic.

24. The method according to claim 19, wherein the step of powering includes the step of alternatively powering the LED device ON and OFF.

25. A computing device comprising:

a processing unit;

a computer port;

a power supply; and

an LED device coupled to the processing unit and the power supply through the computer port,

wherein the processing unit is programmed to sense an event and, in response to the sensing of the event, powers ON the LED device to visually signal the user of the computing device of the event.

26. The computing device according to claim 25, wherein the computer port is a USB port.

27. The computing device according to claim 25, wherein the computer port is an IEEE1394 port.

28. The computing device according to claim 25, wherein the processing unit is programmed to sense an incoming e-mail message.

29. The computing device according to claim 25, wherein the processing unit is programmed to sense an incoming internet telephone call.

30. The computing device according to claim 25, wherein the processing unit is programmed to sense an incoming facsimile.

31. The computing device according to claim 25, wherein the processing unit is programmed to sense a level of network traffic.

32. The computing device according to claim 25, wherein the processing unit is programmed to power the LED device ON and OFF in an alternate manner.

* * * * *