

DANIEL S. PRATT.

Improvement in Machines for Manufacturing Staves.

No. 127,643.

Patented June 4, 1872.

Fig. 1.

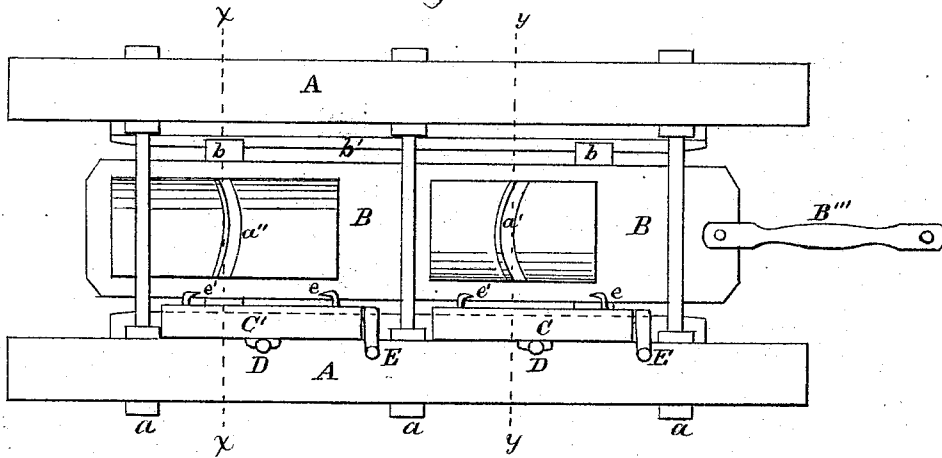

Fig. 2.

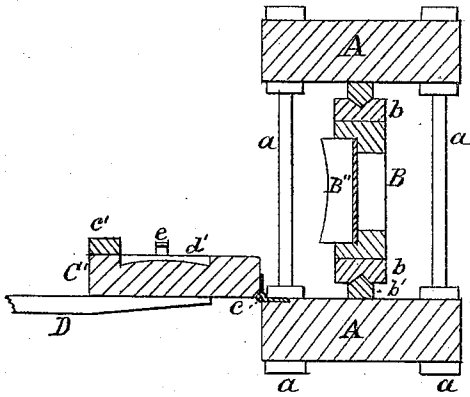
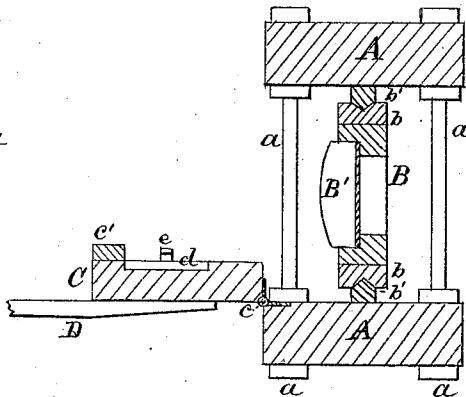

Fig. 3.



Witnesses:

Newton Cranford  
H. A. Daniel

Inventor:

Daniel S. Pratt

# UNITED STATES PATENT OFFICE.

DANIEL S. PRATT, OF ORWELL, NEW YORK.

## IMPROVEMENT IN MACHINES FOR MANUFACTURING STAVES.

Specification forming part of Letters Patent No. 127,643, dated June 4, 1872.

I, DANIEL S. PRATT, of Orwell, in the county of Oswego, in the State of New York, have made certain Improvements in Machines for Dressing Staves, of which the following is a specification:

In the drawing, Figure 1 represents an upright side view of the machine. Fig. 2 is a transverse sectional view through line *x x*; and Fig. 3 is a transverse sectional view through line *y y*.

The object of this invention is to introduce a machine for dressing staves (convex on one side and concave on the other) by reciprocating cutters, thereby making the surfaces much smoother than by a revolving cutter; and it consists in the construction of the hinged stave-holding table, when used in combination with the convex and concave reciprocating planes, as will be more fully hereinafter described.

A represents the top and bottom parts of the supporting frame of the machine; *a a*, the screw-bolt rods that hold and clamp the top and bottom in place. B is a reciprocating stock, made to reciprocate by any known means through or by pitman B''', and has on its face side a convex face, B', and concave face B'', and the proper openings through it to pass the shavings cut by the convex and concave bits or cutters *a'* and *a''*. *b b* are guide-blocks, fast upon the upper and lower sides of the stock B, with V-grooves in their upper and lower sides. *b' b'* are slides with angular rib-shaped inner sides, and upon which the guide-blocks freely slide. C is a stave-holder, hinged at *c* to the lower part of frame A, and has a sink, *d*, in its inner face to receive a flat-sided blank stave. C' is another stave-holder hinged to frame A in the same manner, and has a sink, *d'*, with a convex face therein. DD are operating handles, by which the stave-holders are forced up toward the reciprocating planes, or are turned down, as

seen in Fig. 1. EE are handles pivoted to holder C, and operate the dogs that hold the staves. *e e* are sliding dogs, pivoted to handles EE, and are forced by said handles EE to take hold of and hold the stave fast in its position, while the reciprocating planes form the blank stave into shape. *e' e'* are stationary dogs to hold the stave against the pressure of dogs *e*.

The operation of the machine is as follows: The blank staves being prepared from plank of the proper thickness and width, are first put into, and firmly dogged in, holder C, which, with the stave, is turned up by handle D toward the reciprocating stock B, having the convex plane B' thereon, the reciprocation of which will cut away the face of the stave to be concave, the handle D forcing the holder and stave against the cutter, until the gauge-stop *c'* strikes against the stock B when the concave side of the stave is finished. The stave-holder C is now turned down, the stave, partly finished, undogged, taken out, and placed on the convex bed *d'* of holder C', where it is secured by the dogs in the same manner as before in holder C, then forced toward and against the reciprocating concave cutter *a''* in face B'', until the gauge-stop *c'* strikes against the stock B, when the stave is completely dressed upon both sides ready to be jointed.

Having thus described my invention, what I claim, and desire to secure by Letters Patent, is—

The combination of the hinged stave-holders C and C' with the dogs for holding the staves with the reciprocating stock B, convex face B', with cutter *a'*, and concave face B'', with cutter *a''*, constructed and operating substantially as described.

DANIEL S. PRATT.

Witnesses:

JOHN C. COLVIN,  
LEWIS E. JOY.