

S. G. HOLYOKE.
Farm-Gate Support.

No. 215,925.

Patented May 27, 1879.

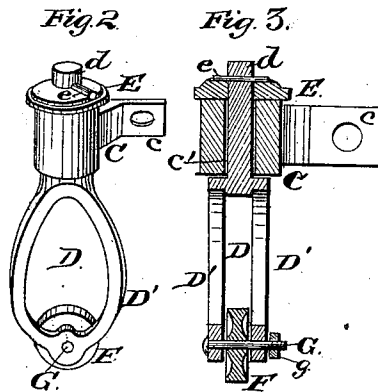
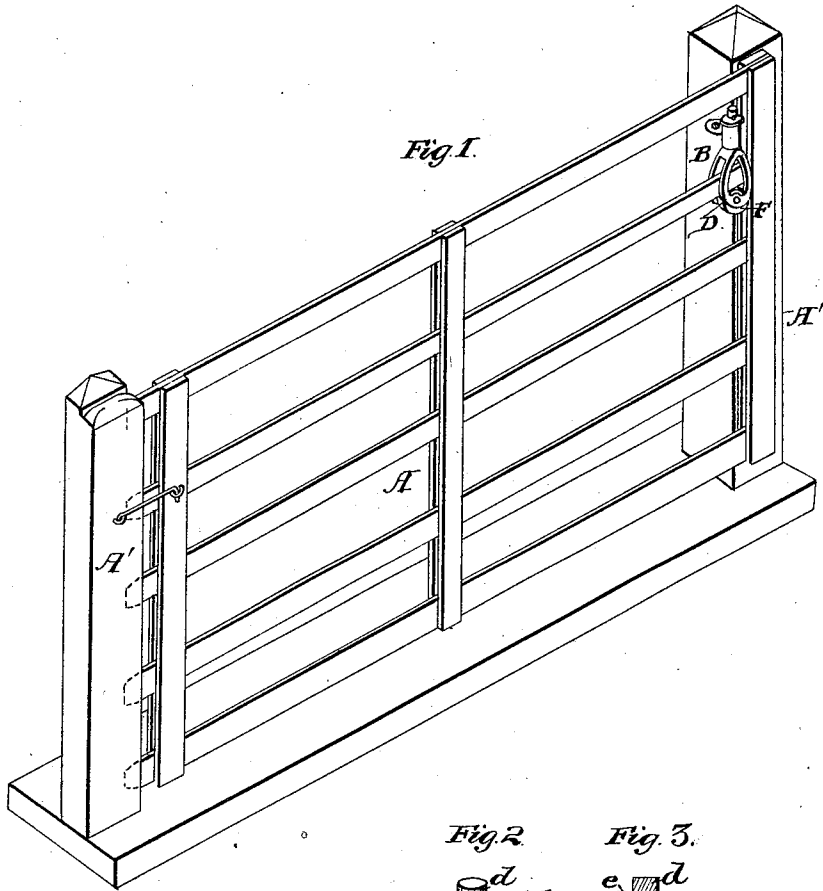

WITNESSES:

F. B. Brock
D. S. Stuart

INVENTOR.

Saml. G. Holyoke
By W. P. Richards,
ATTORNEY.

UNITED STATES PATENT OFFICE.

SAMUEL G. HOLYOKE, OF GALESBURG, ASSIGNOR TO WILLIAM F. LAIRD, OF SAME PLACE, AND BOOKER PICKREL, OF WATAGA, ILLINOIS, ONE-FOURTH TO EACH.

IMPROVEMENT IN FARM-GATE SUPPORTS.

Specification forming part of Letters Patent No. 215,925, dated May 27, 1879; application filed February 5, 1879.

To all whom it may concern:

Be it known that I, SAMUEL G. HOLYOKE, of Galesburg, in the county of Knox and State of Illinois, have invented certain new and useful Improvements in Farm-Gate Supports; and I do hereby declare that the following is a full, clear, and exact description of the invention, which will enable others skilled in the art to which it appertains to make and use the same, reference being had to the accompanying drawings, and to letters of reference marked thereon, which form a part of this specification, in which—

Figure 1 is a perspective view of my improved gate. Fig. 2 is an enlarged perspective view of the hanger alone. Fig. 3 is a vertical sectional view of Fig. 2.

This invention relates to that class of gates which are opened by sliding them back about one-half of their length and then swinging the gate around; and consists in improvements in the hanger, to facilitate attaching the gate thereto, and to prevent snow and sleet from affecting the working of the gate.

Referring to the drawings by letters, the same letter indicating the same part in the different views, A represents a gate, and A' A' posts, constructed and arranged as shown in the drawings, or in any manner common to this class of gates. B represents the hanger, constructed as follows: C is a bracket, with arms *c*, by which it may be secured to one of the posts A', and with a vertical hole, *c'*. D is the gate-carrier proper, its upper end formed into a journal, *d*, which passes through the hole *c'*, and in which it is retained by a washer, E, which fits closely upon the journal *d*, and is held so as to be rotated with the journal by a pin, *e*. The washer E extends outward over the portion of the bracket in which the journal *d* is carried, so as to prevent snow and sleet from collecting about the journal and interfering with its free operations. The lower end of the carrier D is formed into

two arms, D' D'. F is a pulley, journaled on an axial bolt, G, which is held in the lower ends of the arms D' by a nut, *g*, so that the pulley can be readily and easily removed by simply removing the nut *g* and taking out the bolt G.

It will be seen that when the bracket C is secured to the gate-post, as shown at Fig. 1 of the drawings, the gate may be easily and quickly put in working position, as shown at same figure, by removing the pulley F and placing one of the horizontal gate-bars between the arms D'; and then replacing the pulley.

The gate may be opened by sliding it backward about half its length on the pulley F, and then swinging it around on the journal *d*.

This hanger may be easily and quickly attached to any ordinary gate-post, and an ordinary gate be readily and easily connected with the hanger; and the journal, being protected from sleet and snow, will not be affected thereby.

What I claim as new, and desire to secure by Letters Patent, is—

1. In combination with a sliding and swinging gate and a gate-post, a hanger constructed with a journal, *d*, by which it is swiveled to a bracket, C, and with two arms, D' D', having a removable pulley, F, journaled in their lower ends, substantially as and for the purpose specified.

2. In a gate-hanger, the carrier D, journaled in the bracket C, and protected by a washer, E, substantially as and for the purpose specified.

In testimony that I claim the foregoing as my own I affix my signature in presence of two witnesses.

SAMUEL G. HOLYOKE.

Witnesses:

W. B. RICHARDS,
H. A. ALLEN.