



- (51) **International Patent Classification:**  
*A47J 31/44* (2006.01)      *A47J 31/60* (2006.01)
- (21) **International Application Number:**  
PCT/NL2021/050349
- (22) **International Filing Date:**  
01 June 2021 (01.06.2021)
- (25) **Filing Language:** English
- (26) **Publication Language:** English
- (30) **Priority Data:**  
2025751      04 June 2020 (04.06.2020)      NL
- (71) **Applicant: BRAVILOR BONAMAT B.V.** [NL/NL]; Pascalstraat 20, 1704 RD Heerhugowaard (NL).
- (72) **Inventors: RUTTEN, Mathias Anthonius Franciscus;** p/a Pascalstraat 20, 1704 RD Heerhugowaard (NL). **SPIJKER, Antonius Johannes;** p/a Pascalstraat 20, 1704 RD Heerhugowaard (NL).
- (74) **Agent: VAN BREDA, Jacques;** Weteringschans 96, 1017 XS Amsterdam (NL).
- (81) **Designated States** (*unless otherwise indicated, for every kind of national protection available*): AE, AG, AL, AM, AO, AT, AU, AZ, BA, BB, BG, BH, BN, BR, BW, BY, BZ, CA, CH, CL, CN, CO, CR, CU, CZ, DE, DJ, DK, DM, DO, DZ, EC, EE, EG, ES, FI, GB, GD, GE, GH, GM, GT, HN,

HR, HU, ID, IL, IN, IR, IS, IT, JO, JP, KE, KG, KH, KN, KP, KR, KW, KZ, LA, LC, LK, LR, LS, LU, LY, MA, MD, ME, MG, MK, MN, MW, MX, MY, MZ, NA, NG, NI, NO, NZ, OM, PA, PE, PG, PH, PL, PT, QA, RO, RS, RU, RW, SA, SC, SD, SE, SG, SK, SL, ST, SV, SY, TH, TJ, TM, TN, TR, TT, TZ, UA, UG, US, UZ, VC, VN, WS, ZA, ZM, ZW.

- (84) **Designated States** (*unless otherwise indicated, for every kind of regional protection available*): ARIPO (BW, GH, GM, KE, LR, LS, MW, MZ, NA, RW, SD, SL, ST, SZ, TZ, UG, ZM, ZW), Eurasian (AM, AZ, BY, KG, KZ, RU, TJ, TM), European (AL, AT, BE, BG, CH, CY, CZ, DE, DK, EE, ES, FI, FR, GB, GR, HR, HU, IE, IS, IT, LT, LU, LV, MC, MK, MT, NL, NO, PL, PT, RO, RS, SE, SI, SK, SM, TR), OAPI (BF, BJ, CF, CG, CI, CM, GA, GN, GQ, GW, KM, ML, MR, NE, SN, TD, TG).

**Published:**  
— with international search report (Art. 21(3))



WO 2021/246866 A1

(54) **Title:** A COFFEE OR MILK MACHINE AND A METHOD OF OPERATING SUCH A MACHINE

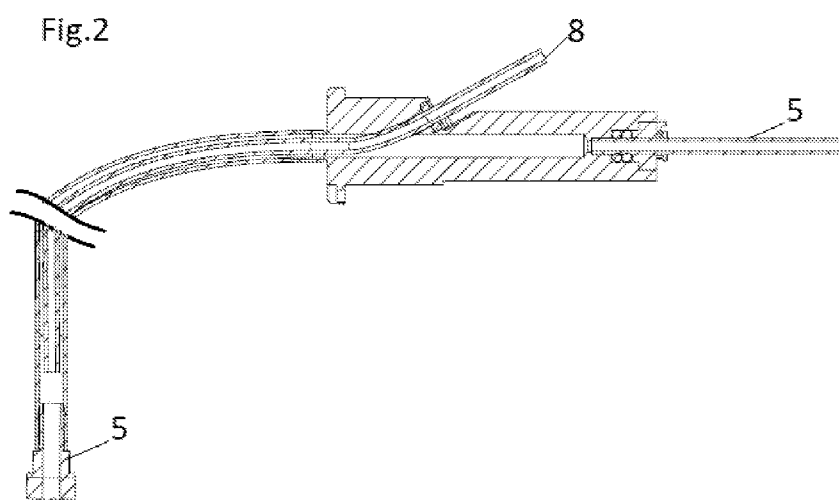

(57) **Abstract:** A coffee machine (1) comprising a frother (2) with an outlet channel (3) for coffee and milk foam, and supply channels (5, 6, 7) for milk, air, and steam respectively, and provided with a nonreturn valve (15) to prevent a fluid in one of the channels from flowing in an undesirable direction, wherein the coffee machine (1) is further provided with a clean water supply channel (8) that connects to the milk supply channel (5) with a T-junction (9) distant from the frother (2), wherein the T-junction (9) further connects to a source channel (11) for the milk.

A coffee or milk machine and a method of operating such a machine

The invention relates to a machine comprising a  
5 frother with an outlet channel for foamed milk, and supply  
channels for milk, air, and steam respectively, and provided  
with a nonreturn valve to prevent a fluid in one of the chan-  
nels from flowing in an undesirable direction. The invention  
also relates to a method of operating such a machine. The in-  
10 vention applies to both a coffee machine and a machine to pro-  
vide foamed milk only.

EP 2 695 558 discloses a machine which is embodied as  
a coffee machine. In this known machine the nonreturn valve is  
provided in a supply channel for air that connects to the sup-  
15 ply channel for milk, and prevents that milk will flow into  
the air channel.

When dispensing coffee and foamed milk with such a  
coffee machine, milk will be sucked into the frother by means  
of the venturi action that the frother provides. The energy  
20 that is required to provide pressure and temperature to the  
mixture leaving the frother comes from the steam supply, and  
the air that is supplied to the frother is used to form the  
foamed milk. This operation is repeated with every serving.  
Between the servings, the supply channel for the milk is left  
25 idle. Consequently the milk channel fills with air and becomes  
"dry". Eventually the leftover milk residues in the milk chan-  
nel will get spoiled. To prevent this spoiling of left-behind  
milk, frequent cleaning of the milk supply channel is re-  
quired.

30 Another drawback of this operation is that when the  
frother operation starts, the air in the milk supply channel  
must first leave the milk supply channel. This results in that  
initially, before the milk foam can start to leave the frother  
in a stable flow, an irregular sequence of splashing milk  
35 droplets leaves the frother and soils the receiving cup.

In addition to soiling the cup, the milk foam bubbles  
initially have different sizes. When these different size milk  
foam bubbles are mixed with the subsequent milk foam bubbles  
with constant bubble size, a so-called disproportionation oc-  
40 curs, i.e. a diffusion of gas from smaller foam bubbles to

larger foam bubbles in the milk/air mixture. This leads to even larger foam bubbles and makes the foam unstable. In other words the foam will disappear quicker than is desirable. This is an important drawback, particularly when the milk foam is used as a top layer on top of coffee since the service life of the milk foam is an important aspect relevant to the catering industry. There is not only the image of the milk foam, i.e. the quality of the served cup of coffee, but also the service life of the milk foam, which sets a limit to the still acceptable delay time at which the cup of coffee with milk foam should be served.

DE-A-10 2011 006 483 discloses a machine according to the preamble of claim 1.

The invention has as a first object to provide a solution for one or more of the above mentioned problems.

Another object of the invention is to provide a machine which provides a solution to the above problems, yet is still compact as required by market-demand.

According to the invention a machine and a method of operating such a machine are proposed in accordance with one or more of the appended claims.

In a first aspect the invention proposes a machine comprising a frother with an outlet channel for milk foam, and supply channels for milk, steam, and air respectively, and provided with a nonreturn valve to prevent a fluid in one of the channels from flowing in an undesirable direction, wherein the machine is further provided with a clean water supply channel that connects to the milk supply channel with a T-junction distant from the frother, wherein the T-junction further connects to a source channel for the milk, wherein the clean water supply channel and the milk supply channel are embodied as a tube in tube construction.

The clean water supply channel serves different purposes, amongst which purposes is that it provides an easy way to introduce water in the milk supply channel after a serving of foamed milk, rather than to leave air inside the milk supply channel in-between separate servings of foamed milk. The presence of water rather than air in the milk supply channel further contributes to the extension of time that the machine may be in operation without intermediate cleaning of the milk

supply channel. Further the clean water supply channel can in general also be used to clean the milk supply channel. Even further the clean water supply channel makes possible to avoid the initial sputtering of milk leaving the frother at the start of dispensing milk foam. As mentioned above this initial sputtering undesirably soils the cup. Further the feature that the clean water supply channel and the milk supply channel are embodied as a tube in tube construction makes handling of the respective channels very easy when replacement of a milk supply to which the respective channels lead, is envisaged.

To promote the avoidance of the initial sputtering of milk, it is preferred that the clean water supply channel comprises a control valve connected to a controller which is arranged to cause that during a first stage a burst of clean water is introduced into the milk supply channel immediately before milk enters the milk supply channel coming from the source channel for the milk.

It is further preferred that the T-junction is provided with the nonreturn valve to prevent that clean water from the clean water supply channel enters the source channel for the milk. Preferably the nonreturn valve is of the duck-bill type.

The time between the regular cleaning operations of the machine may be further extended by arranging that at least one of the supply channel for the milk and the source channel for the milk are provided with an internal coating with hydrophobic and/or oleophobic properties.

Suitably the coating comprises nanoparticles of silver or silver compounds. And preferably the nanoparticles have a dimension between  $10^{-10}$  and  $10^{-7}$  m, preferably in the range 1 - 100 nm, more preferably in the range 10 - 60 nm.

The invention is also embodied in a method of operating a machine according to the invention, wherein at the start of operating the frother, initially a temporary burst of water supplied by the clean water supply channel is guided in and through the milk supply channel towards the frother.

Preferably the initial temporary burst of water is applied for a duration between 0.01 and 3 seconds.

More preferably the initial temporary burst of water is applied for a duration between 0.05 and 0.15 seconds.

It is further preferred that after finalizing the operation of the frother, clean water supplied by the clean water supply is guided through the milk supply channel, the frother and the outlet channel.

5 Beneficially at repeated intervals a container with cleaning agent is placed in fluid communication with the source channel for the milk so as to rinse and clean the machine.

10 Suitably the cleaning agent is both a descalant to remove limescale and a microbicidal to destroy microbes, such as bacteria.

Preferably the cleaning agent is an acid descalant and microbicidal, comprising 50-150 ppm peracetic acid.

15 The invention will hereinafter be further elucidated with reference to a schematic exemplary drawing of a coffee machine according to the invention that is not limiting as to the appended claims. Although the following example relates to a coffee machine, the inventors stress the point that the invention also applies to a machine that exclusively provides  
20 foamed milk. This is also logical since the principles of the invention exclusively relate to the foaming of milk and upgrading the quality of the foam, particularly the stability of the foam as explained hereinabove.

25 In the drawing of figures 1 and 2 the principle features of a coffee machine according to the invention are shown.

The rectangle 1 of dotted lines in fig. 1 symbolizes a coffee machine according to the invention, which comprises a frother 2 with an outlet channel 3 for coffee and milk foam.  
30 The outlet channel 3 provides the coffee and milk foam to a cup underneath the outlet channel 3.

The coffee machine 1 further has a milk supply channel 5, a steam supply channel 6, and an air supply channel 7 connected to the frother 2.

35 The coffee machine 1 is further provided with a clean water supply channel 8 that connects to the milk supply channel 5 with a T-junction 9 distant from the frother 2. It is noted that the clean water supply channel 8 and the milk supply channel 5 are embodied as a tube in tube construction as  
40 shown in fig. 2. This makes handling of the respective

channels 5, 8 very easy when replacement of a milk reservoir 12 to which the respective channels lead, is envisaged.

The T-junction 9 may be provided at any feasible position, both within the limits of the coffee machine 1, or outside the coffee machine 1. The T-junction 9 may be positioned within a cooled environment 10, or outside such a cooled environment 10. The T-junction 9 further connects to a source channel 11 for the milk, which in the shown schematic drawing is placed inside a reservoir 12 for milk which is placed inside a cooled environment 10. This source channel 11 can be very short, for instance 2 mm. It is also feasible that the T-junction is positioned outside the reservoir 12 but preferably inside the cooled environment 10.

Preferably the clean water supply channel 8 comprises a control valve 13 connected to a controller 14 which is arranged to cause that during a first stage of dispensing coffee and milk foam with the frother 2, a burst of clean water is introduced into the milk supply channel 5 immediately before milk enters the milk supply channel 5 coming from the source channel 11 for the milk.

Preferably the T-junction 9 is provided with the non-return valve 15 to prevent that clean water from the clean water supply channel 8 enters the source channel 11 for the milk.

Other beneficial features are as follows:

- at least one of the milk supply channel 5 and the source channel 11 for the milk are provided with an internal coating with hydrophobic and/or oleophobic properties;

- the coating comprises nanoparticles of silver or silver compounds;

- the nanoparticles have a dimension between  $10^{-10}$  and  $10^{-7}$  m, preferably in the range 1 - 100 nm, more preferably in the range 10 - 60 nm.

The features of the invention provide the possibility to "jump start" the venturi of the frother 2. This is done by opening the valve 13 for a short period at the start of dispensing coffee and milk foam. This will smoothen the start of the dispense by speeding up the flow towards the frother 2. It will also create a stable start situation by the milk supply channel 5 and frother 2 being filled with water, which results

in a more equal dispense of volume and less difference between the first and second cup quality. At the end of any dispensing cycle the valve 13 is opened again to remove the milk from the milk supply channel 5. This prevents the occurrence of spoiled milk in this milk supply channel 5. This end cycle is optional. As an alternative one could also use a "cleanshot" after a certain amount of time. This cleanshot contains a shot of water that removes the milk from the milk supply channel 5, the frother 2 and the outlet channel 3.

Another benefit is that no milk will be stored in un-cooled places so as to prevent bacterial growth. In the prior art frequent user actions are required to keep the milk supply channel 5 clean and safe. This is considered user unfriendly and is at all times a hygiene risk. One of the beauties of the invention is that the proposed solution does not need a lot of components, does not require the application of a cool box, and does not have to apply such a cool box as a part inside the coffee machine. On the contrary, the invention provides a solution at low cost while maintaining flexibility of use.

The preferred operation of the coffee machine 1 of the invention is that at the start of dispensing milk by operating the frother 2, initially a temporary burst of water supplied by the clean water supply channel 8 is guided in and through the milk supply channel 5 towards the frother 2. For this purpose valve 13 opens for a short period to initiate the flow of water towards the frother 2. Preferably the initial temporary burst of water is applied for a duration between 0.01 and 3 seconds. More preferably the initial temporary burst of water is applied for a duration between 0.05 and 0.15 seconds.

Steam is dispensed into a venturi chamber inside the frother 2. This will create under pressure in milk supply channel 5 and will keep the milk flowing towards the frother 2 after closing off the valve 13. The milk originates from the container 12, preferably placed in a cooled environment 10, and arrives in the milk supply channel 5 via the source channel 11 for the milk, which source channel 11 connects with T-junction 9 to the milk supply channel 5. When arriving in the frother 2, the milk will be mixed with air which is also sucked in by the under pressure created by the venturi of the frother 2.

After finalizing the dispensing of coffee by the frother 2, clean water supplied by the clean water supply channel 8 is guided through the milk supply channel 5, the frother 2 and the outlet channel 3. For this purpose the valve 13 will be opened and water will displace the milk in the milk supply channel 5. The water will not be able to enter the milk reservoir 12 because this is prevented by the non-return valve 15 in the T-junction 9.

It is further preferable that at repeated intervals a container with cleaning agent is placed in fluid communication with the source channel 11 for the milk so as to rinse and clean the coffee machine 1. Suitably the cleaning agent is both a descalant to remove limescale and a microbicidal to destroy microbes, such as bacteria. Preferably the cleaning agent is an acid descalant and microbicidal, comprising 50-150 ppm peracetic acid.

Although the invention has been discussed in the foregoing with reference to an exemplary embodiment of a coffee machine and a method of its operation, the invention is not restricted to this particular embodiment which can be varied in many ways without departing from the invention. The discussed exemplary embodiment shall therefore not be used to construe the appended claims strictly in accordance therewith. On the contrary the embodiment is merely intended to explain the wording of the appended claims without intent to limit the claims to this exemplary embodiment. The scope of protection of the invention shall therefore be construed in accordance with the appended claims only, wherein a possible ambiguity in the wording of the claims shall be resolved using this exemplary embodiment.

CLAIMS

1. A machine (1) comprising a frother (2) with an outlet channel (3) for milk foam, and supply channels (5, 6, 7) for milk, steam, and air respectively, and provided with a nonreturn valve (15) to prevent a fluid in one of the channels from flowing in an undesirable direction, wherein the machine (1) is further provided with a clean water supply channel (8) that connects to the milk supply channel (5) with a T-junction (9) distant from the frother (2), wherein the T-junction (9) further connects to a source channel (11) for the milk, **characterized in that** the clean water supply channel (8) and the milk supply channel (5) are embodied as a tube in tube construction.

2. The machine of claim 1, **characterized in that** the clean water supply channel (8) comprises a control valve (13) connected to a controller (14) which is arranged to cause that a burst of clean water is introduced into the milk supply channel (5) immediately before milk enters the milk supply channel (5) coming from the source channel (11) for the milk.

3. The machine of claim 1 or 2, **characterized in that** the T-junction (9) is provided with the nonreturn valve (15) to prevent that clean water from the clean water supply channel (8) enters the source channel (11) for the milk.

4. The machine of claim 3, **characterized in that** the nonreturn valve (15) is of the duckbill type.

5. The machine of any one claims 1 - 4, **characterized in that** at least one of the milk supply channel (5) and the source channel (11) for the milk is provided with an internal coating with hydrophobic and/or oleophobic properties.

6. The machine of claim 5, **characterized in that** the coating comprises nanoparticles of silver or silver compounds.

7. The machine of claim 6, **characterized in that** the nanoparticles have a dimension between  $10^{-10}$  and  $10^{-7}$  m, preferably in the range 1 - 100 nm, more preferably in the range 10 - 60 nm.

8. The machine according to any one of claims 1 - 7, **characterized in that** the machine is a coffee machine.

9. Method of operating a machine according to any one of claims 1 - 8, **characterized in that** at the start of

operating the frother (2), initially a temporary burst of water supplied by the clean water supply channel (8) is guided in and through the milk supply channel (5) towards the frother (2).

5           10. Method according to claim 9, **characterized in that** the initial temporary burst of water is applied for a duration between 0.01 and 3 seconds.

10           11. Method according to claim 10, **characterized in that** the initial temporary burst of water is applied for a duration between 0.05 and 0.15 seconds.

15           12. Method according to any one of claims 9 - 11, **characterized in that** after operating the frother (2), clean water supplied by the clean water supply channel (8) is guided through the milk supply channel (5), the frother (2) and the outlet channel (3).

20           13. Method according to any one of claims 9 - 12, **characterized in that** at repeated intervals a container with cleaning agent is placed in fluid communication with the source channel (11) for the milk so as to rinse and clean the machine (1).

          14. Method according to claim 13, **characterized in that** the cleaning agent is both a descalant to remove lime-scale and a microbicidal to destroy microbes, such as bacteria.

25           15. Method according to claim 13 or 14, **characterized in that** the cleaning agent is an acid descalant and microbicidal, comprising 50-150 ppm peracetic acid.

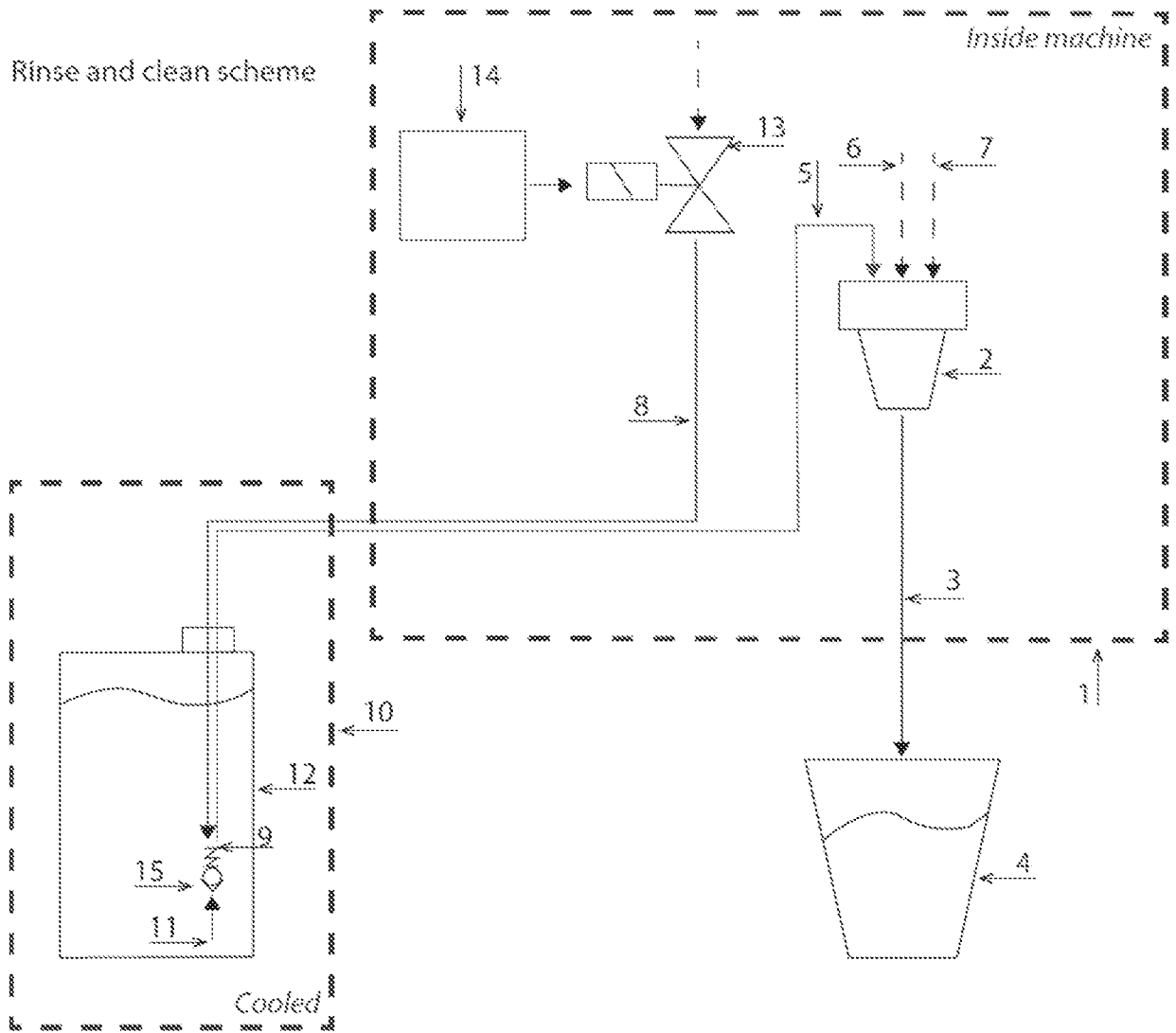
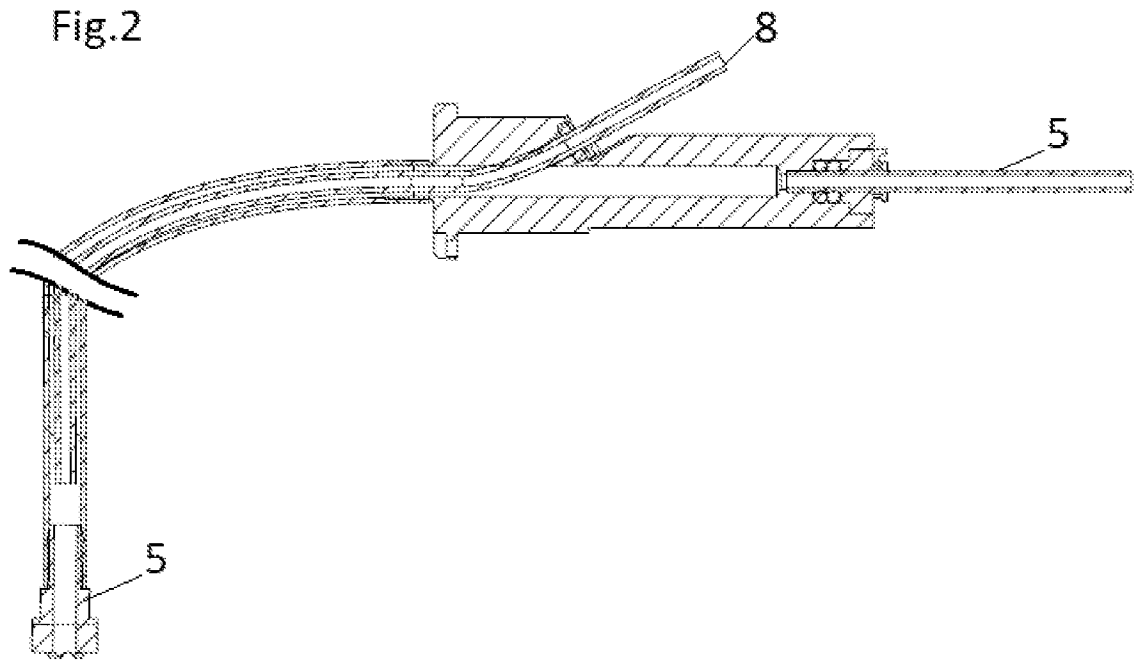

Fig. 1



INTERNATIONAL SEARCH REPORT

International application No  
PCT/NL2021/050349

A. CLASSIFICATION OF SUBJECT MATTER  
INV. A47J31/44 A47J31/60  
ADD.  
According to International Patent Classification (IPC) or to both national classification and IPC

B. FIELDS SEARCHED  
Minimum documentation searched (classification system followed by classification symbols)  
A47J  
Documentation searched other than minimum documentation to the extent that such documents are included in the fields searched

Electronic data base consulted during the international search (name of data base and, where practicable, search terms used)  
EPO-Internal, WPI Data

C. DOCUMENTS CONSIDERED TO BE RELEVANT

Category*	Citation of document, with indication, where appropriate, of the relevant passages	Relevant to claim No.
A	DE 10 2011 006483 A1 (BSH BOSCH SIEMENS HAUSGERAETE [DE]) 4 October 2012 (2012-10-04) cited in the application paragraphs [0030], [0031], [0034], [0038] - [0040], [0043]; figures 1, 5, 6 -----	1-15
A	DE 199 55 195 A1 (NIRO PLAN AG ZUG [CH]) 17 May 2001 (2001-05-17) column 3, line 43 - column 4, line 12 column 4, lines 48-57 figure -----	1,3,8,9, 12
A	US 2008/163896 A1 (IOANNONE MATTEO [CH]) 10 July 2008 (2008-07-10) paragraphs [0035] - [0037], [0039] - [0041], [0051], [0052]; figures 2, 3 ----- -/--	13-15

Further documents are listed in the continuation of Box C.  See patent family annex.

\* Special categories of cited documents :

"A" document defining the general state of the art which is not considered to be of particular relevance	"T" later document published after the international filing date or priority date and not in conflict with the application but cited to understand the principle or theory underlying the invention
"E" earlier application or patent but published on or after the international filing date	"X" document of particular relevance; the claimed invention cannot be considered novel or cannot be considered to involve an inventive step when the document is taken alone
"L" document which may throw doubts on priority claim(s) or which is cited to establish the publication date of another citation or other special reason (as specified)	"Y" document of particular relevance; the claimed invention cannot be considered to involve an inventive step when the document is combined with one or more other such documents, such combination being obvious to a person skilled in the art
"O" document referring to an oral disclosure, use, exhibition or other means	"&" document member of the same patent family
"P" document published prior to the international filing date but later than the priority date claimed	

Date of the actual completion of the international search  26 July 2021	Date of mailing of the international search report  05/08/2021
---	--

Name and mailing address of the ISA/ European Patent Office, P.B. 5818 Patentlaan 2 NL - 2280 HV Rijswijk Tel. (+31-70) 340-2040, Fax: (+31-70) 340-3016	Authorized officer  Novelli, Bruno
--	--

## INTERNATIONAL SEARCH REPORT

International application No  
PCT/NL2021/050349

C(Continuation). DOCUMENTS CONSIDERED TO BE RELEVANT		
Category*	Citation of document, with indication, where appropriate, of the relevant passages	Relevant to claim No.
A	US 2011/005407 A1 (REYHANLOO SHAHRYAR [CH]) 13 January 2011 (2011-01-13) paragraphs [0047], [0048], [0054], [0055], [0059], [0060]; figures 2, 4 -----	1,3,8, 12-15
A	EP 2 695 558 A1 (BSH BOSCH SIEMENS HAUSGERAETE [DE]) 12 February 2014 (2014-02-12) cited in the application paragraphs [0018], [0019], [0023]; figure -----	1,8,12

# INTERNATIONAL SEARCH REPORT

Information on patent family members

International application No

PCT/NL2021/050349

Patent document cited in search report	Publication date	Patent family member(s)	Publication date
DE 102011006483 A1	04-10-2012	NONE	
-----			
DE 19955195 A1	17-05-2001	NONE	
-----			
US 2008163896 A1	10-07-2008	AT 487406 T	15-11-2010
		DE 102006047969 A1	17-04-2008
		EP 1911382 A1	16-04-2008
		ES 2355847 T3	31-03-2011
		JP 2008094499 A	24-04-2008
		US 2008163896 A1	10-07-2008
-----			
US 2011005407 A1	13-01-2011	AT 544382 T	15-02-2012
		AU 2010202825 A1	27-01-2011
		CA 2708473 A1	08-01-2011
		CN 101947061 A	19-01-2011
		EP 2272408 A1	12-01-2011
		EP 2272409 A1	12-01-2011
		ES 2381804 T3	31-05-2012
		PL 2272409 T3	31-08-2012
		PT 2272409 E	15-05-2012
		SG 168471 A1	28-02-2011
		US 2011005407 A1	13-01-2011
-----			
EP 2695558 A1	12-02-2014	DE 102012214105 A1	13-02-2014
		EP 2695558 A1	12-02-2014
-----			