

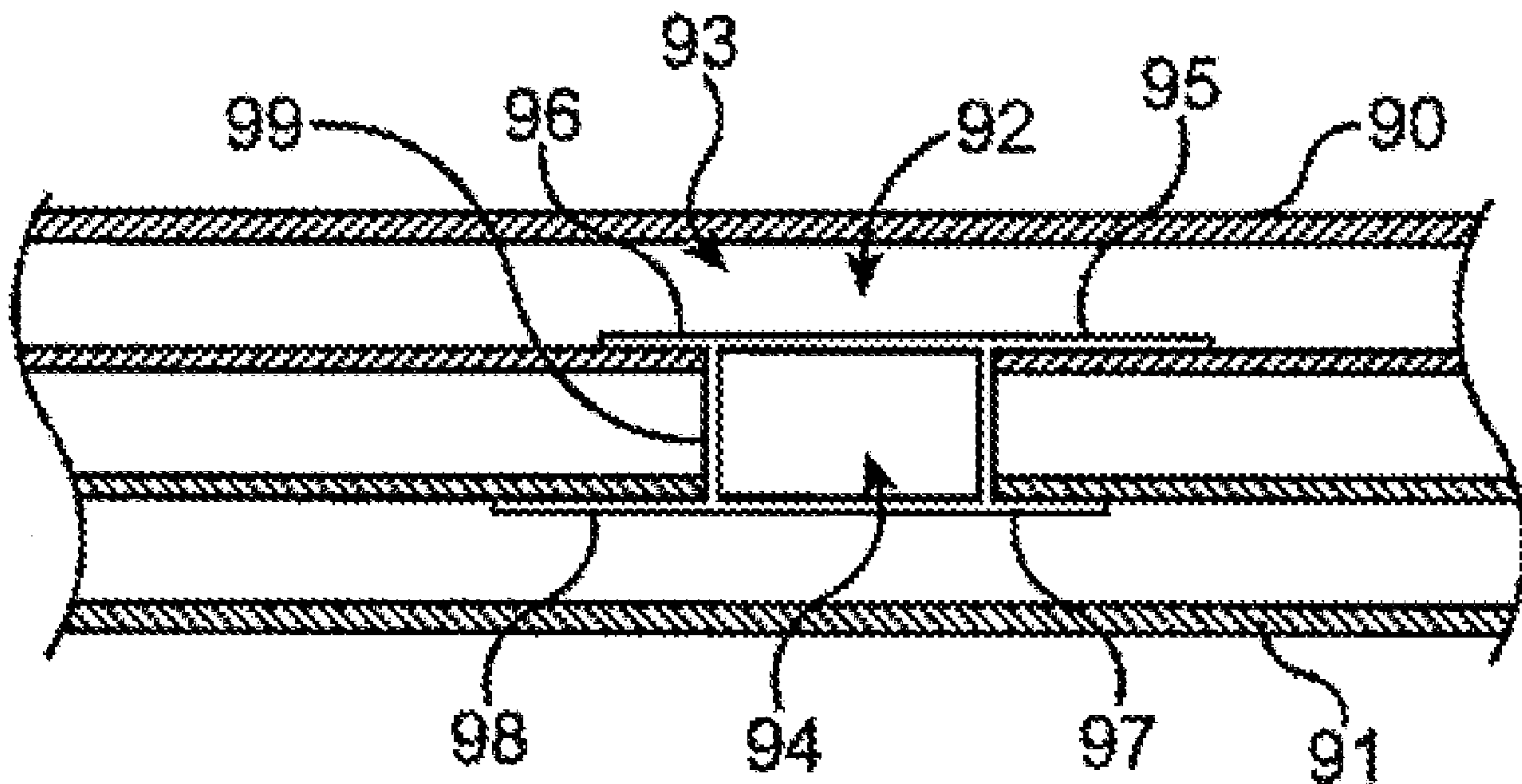

(86) Date de dépôt PCT/PCT Filing Date: 2008/03/26
 (87) Date publication PCT/PCT Publication Date: 2008/10/16
 (45) Date de délivrance/Issue Date: 2011/07/12
 (85) Entrée phase nationale/National Entry: 2009/10/01
 (86) N° demande PCT/PCT Application No.: US 2008/058315
 (87) N° publication PCT/PCT Publication No.: 2008/124314
 (30) Priorité/Priority: 2007/04/04 (US11/696,635)

(51) Cl.Int./Int.Cl. *A61F 2/06* (2006.01)
 (72) Inventeurs/Inventors:
 BRENNEMAN, RODNEY A., US;
 FLAHERTY, J. CHRISTOPHER, US;
 SCHAEFER, DEAN, US;
 DAVIS, PETER, US;
 KELLERMAN, BRAD, US
 (73) Propriétaire/Owner:
 ROX MEDICAL, INC., US
 (74) Agent: BORDEN LADNER GERVAIS LLP

(54) Titre : DISPOSITIF ET PROCEDE DE MISE EN PLACE D'UNE FISTULE ARTERIO-VEINEUSE ARTIFICIELLE
 (54) Title: DEVICE AND METHOD FOR ESTABLISHING AN ARTIFICIAL ARTERIO-VEINUS FISTULA



(57) Abrégé/Abstract:

A shunt rivet for implantation in the aorta and inferior vena cava to treat chronic obstructive pulmonary disease, and a method of treating chronic obstructive pulmonary disease.

(12) INTERNATIONAL APPLICATION PUBLISHED UNDER THE PATENT COOPERATION TREATY (PCT)

(19) World Intellectual Property Organization
International Bureau(43) International Publication Date
16 October 2008 (16.10.2008)

PCT

(10) International Publication Number
WO 2008/124314 A1(51) International Patent Classification:
A61F 2/01 (2006.01)(74) Agents: HAN, Johny U. et al.; Levine Bagade Han LLP,
2483 E. Bayshore Road, Suite 100, Palo Alto, California
94303 (US).(21) International Application Number:
PCT/US2008/058315(81) Designated States (unless otherwise indicated, for every
kind of national protection available): AE, AG, AL, AM,
AO, AT, AU, AZ, BA, BB, BG, BH, BR, BW, BY, BZ, CA,
CH, CN, CO, CR, CU, CZ, DE, DK, DM, DO, DZ, EC, EE,
EG, ES, FI, GB, GD, GE, GH, GM, GT, HN, HR, HU, ID,
IL, IN, IS, JP, KE, KG, KM, KN, KP, KR, KZ, LA, LC,
LK, LR, LS, LT, LU, LY, MA, MD, ME, MG, MK, MN,
MW, MX, MY, MZ, NA, NG, NI, NO, NZ, OM, PG, PH,
PL, PT, RO, RS, RU, SC, SD, SE, SG, SK, SL, SM, SV,
SY, TJ, TM, TN, TR, TT, TZ, UA, UG, US, UZ, VC, VN,
ZA, ZM, ZW.

(22) International Filing Date: 26 March 2008 (26.03.2008)

(25) Filing Language: English

(26) Publication Language: English

(30) Priority Data:
11/696,635 4 April 2007 (04.04.2007) US(71) Applicant (for all designated States except US): ROX
MEDICAL, INC. [US/US]; 5825 Avenida Encinas, Suite
103, Carlsbad, California 92008 (US).

(72) Inventors; and

(75) Inventors/Applicants (for US only): BRENNEMAN,
Rodney A. [US/US]; 34002 Las Palmas Del Mar, San
Juan Capistrano, California 92675 (US). FLAHERTY,
J. Christopher [US/US]; 242 Ipswich Road, Topsfield,
Massachusetts 01983 (US). SCHAEFER, Dean [US/US];
29 Aurora, Aliso Viejo, California 92656 (US). DAVIS,
Peter [US/US]; 32921 Danapine, Dana Point, California
92629 (US). KELLERMAN, Brad [US/US]; 10259
Spruce Woodland Way, Escondido, California 92026 (US).(84) Designated States (unless otherwise indicated, for every
kind of regional protection available): ARIPO (BW, GH,
GM, KE, LS, MW, MZ, NA, SD, SL, SZ, TZ, UG, ZM,
ZW), Eurasian (AM, AZ, BY, KG, KZ, MD, RU, TJ, TM),
European (AT, BE, BG, CH, CY, CZ, DE, DK, EE, ES, FI,
FR, GB, GR, HR, HU, IE, IS, IT, LT, LU, LV, MC, MT, NL,
NO, PL, PT, RO, SE, SI, SK, TR), OAPI (BF, BJ, CF, CG,
CI, CM, GA, GN, GQ, GW, ML, MR, NE, SN, TD, TG).**Declaration under Rule 4.17:**— as to applicant's entitlement to apply for and be granted a
patent (Rule 4.17(ii))**Published:**

— with international search report

[Continued on next page]

(54) Title: DEVICE AND METHOD FOR ESTABLISHING AN ARTIFICIAL ARTERIO-VEIN FISTULA

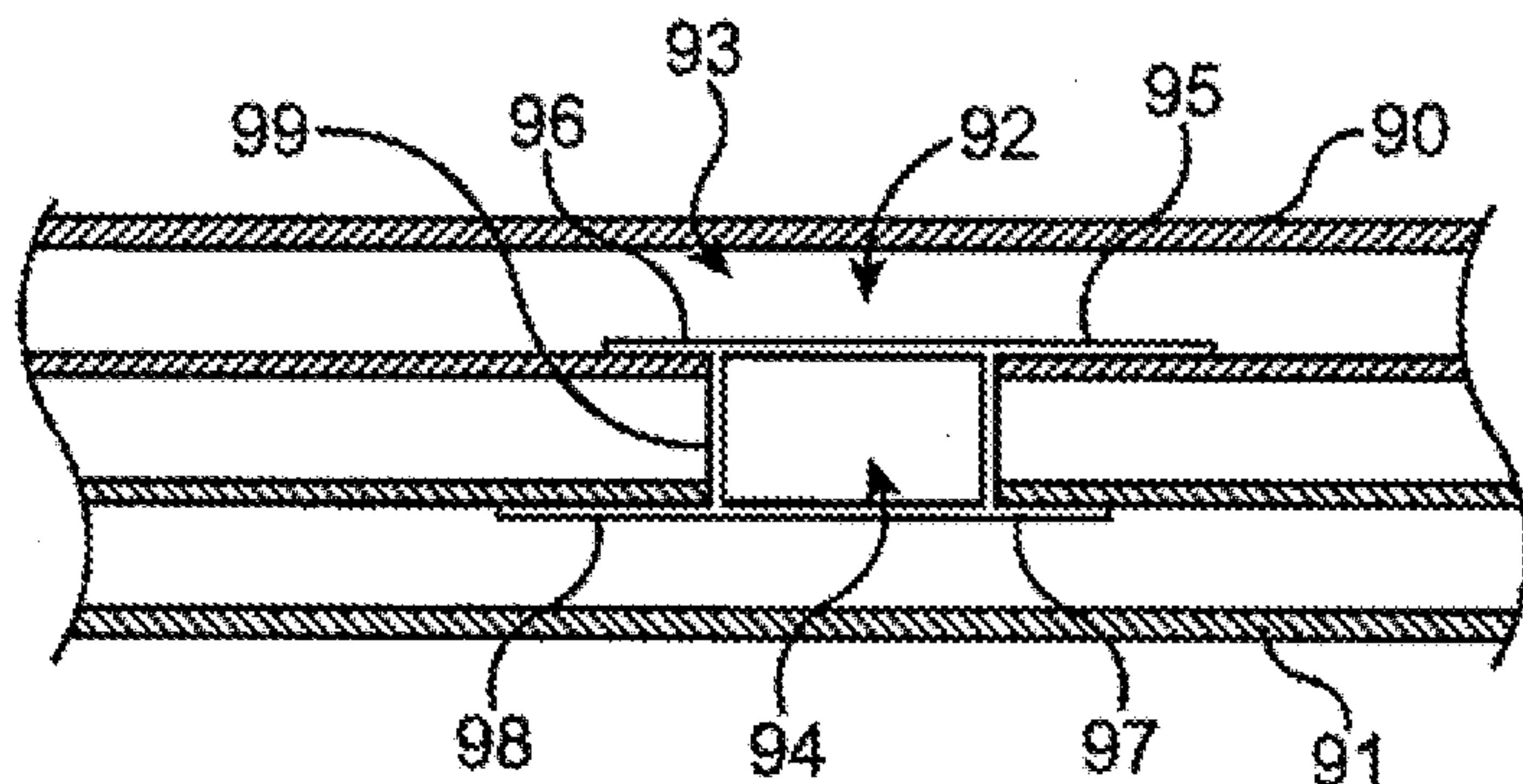

FIG. 28

(57) Abstract: A shunt rivet for
implantation in the aorta and inferior
vena cava to treat chronic obstructive
pulmonary disease, and a method of
treating chronic obstructive
pulmonary disease.

WO 2008/124314 A1

WO 2008/124314 A1



— *before the expiration of the time limit for amending the claims and to be republished in the event of receipt of amendments*

DEVICE AND METHOD FOR ESTABLISHING AN ARTIFICIAL ARTERIO-VEINOUS FISTULA

FIELD OF THE INVENTION

[0002] The inventions described below relate to treatments for pulmonary hypertension and vascular surgery.

BACKGROUND OF THE INVENTION

[0003] Chronic obstructive pulmonary disease (COPD), chronic hypoxia, hypertension, and left ventricular hypertrophy and pulmonary hypertension are diseases of the cardiopulmonary system. Chronic obstructive pulmonary disease (COPD), which includes chronic bronchitis and emphysema, is a slowly progressive lung disease caused primarily by smoking. In COPD, the lungs are damaged and the airways are partly obstructed, making it difficult to breath and leading to a gradual loss of lung function. Symptoms of COPD include chronic cough, excessive sputum production, low blood oxygen levels and severe disabling shortness of breath. COPD represents the fourth leading cause of death in the United States. Chronic hypoxia (reduction of oxygen supply to the body despite adequate blood flow through the body), hypertension, and left ventricular hypertrophy are related conditions which may be symptomatic of COPD or coincident with COPD.

[0004] These serious conditions affect many people, and the primary treatments are merely ameliorative. The primary treatments for COPD include avoidance of irritants such as tobacco smoke and breathing supplemental oxygen. In advanced cases of COPD, lung reduction surgery is sometimes performed, but it is not clear that it helps. There is no known cure for COPD.

[0005] An aortocaval fistula (ACF) is a rare clinical condition that can be either spontaneous (80% of the cases), related to abdominal aortic aneurysm, or the result of

some trauma such as lumbar disk surgery. It is currently seen as a defect that should be cured with surgery and, possibly, stent-graft implantation in the aorta.

[0006] **Contrary to this understanding, an intentionally formed aortocaval fistula** appears to be a viable treatment for COPD. Recently, in U.S. Publication 2004-0249335 A1, entitled Implantable Arteriovenous Shunt Device and listing John L. Faul, Toshihiko Nishimura, Peter N. Kao & Ronald G. Pearl as inventors, we propose creation of an artificial aortocaval fistula as a treatment for COPD, and we disclose the method of creating the fistula and an implantable shunt for maintaining the aortocaval fistula.

[0007] **Shunts or stents for connecting blood vessels have been proposed for the treatment of coronary artery disease. Makower, Device, System And Method For Interstitial Transvascular Intervention, U.S. Pat. No. 6,746,464 (Jun. 8, 2004) (filed Oct. 28, 1998) discloses a stent with a short tubular section spanning the thickness of a coronary artery and an adjacent parallel coronary vein. This stent includes "clovers" on either end of the stent, and these clovers fold radially outwardly to obstruct movement of the stent through the vessel walls. Two clovers on the proximal end of the stent are orthogonal (relative to the radial cross section of the stent) to two clovers on the distal end of the stent, and the interconnecting wires are parallel to the longitudinal axis of the device.**

SUMMARY OF THE INVENTION

[0008] **The devices and methods described below provide for treatment of COPD, hypertension (e.g., pulmonary hypertension, cardiac hypertension, etc.), and left ventricular hypertrophy, and chronic hypoxia. A vascular shunt rivet is disclosed which serves to hold contiguous points of the patient's aorta and inferior vena cava (or other arteries and there associated veins, such as the femoral artery and femoral vein, or the carotid artery and the carotid vein) together and maintain an open flow path from the aorta to the vena cava. The device functions as a rivet, holding the two vessel walls in close proximity, and as a shunt, permitting and maintaining flow from one blood vessel to the other. The device is implanted, between the aorta and inferior vena cava, as a treatment for pulmonary hypertension, COPD and chronic hypoxia.**

[0009] **The shunt rivet is provided in the form of an expandable wire frame structure adapted for transcutaneous delivery and deposit at the desired implantation site. The wire**

frame structure may be compressed into a small diameter configuration to fit within the distal tip of a delivery catheter. Upon expulsion from the catheter, the wire frame structure resiliently or pseudoelastically expands into a flow-through rivet comprising a tube with expanded heads at either end. When the rivet is released within an artificial fistula formed through the aorta and vena cava walls, it expands to trap the walls between the two expanded heads. The tubular section between the two expanded head may resiliently expand, and may also be balloon-expanded or otherwise plastically deformed to enlarge the flow-through lumen of the tubular section.

BRIEF DESCRIPTION OF THE DRAWINGS

- [0010] FIG. 1 illustrates the method of installing the shunt rivet to create and maintain an artificial aortocaval fistula.
- [0011] FIG. 2 illustrates an aortocaval shunt rivet in its restrained condition.
- [0012] FIG. 3 illustrates the aortocaval shunt rivet of FIG. 2 in a resiliently expanded configuration.
- [0013] FIG. 4 is a perspective view of the aortocaval shunt rivet of FIG. 2 in a resiliently expanded configuration.
- [0014] FIG. 5 illustrates the aortocaval shunt rivet of FIG. 2 in a fully expanded configuration.
- [0015] FIGS. 6 through 11 illustrate the deployment of the aortocaval shunt rivet of FIG. 2.
- [0016] FIG. 12 illustrates an aortocaval shunt rivet with asymmetrically shaped distal and proximal flanges.
- [0017] FIG. 13 illustrates an aortocaval shunt rivet with asymmetrically shaped distal and proximal flanges.
- [0018] FIGS. 14, 15 and 16 illustrate an aortocaval shunt rivet with strut members that form diamond-shaped cells in the central section upon expansion.
- [0019] FIGS. 17 and 18 illustrates an aortocaval shunt rivet formed with a single wired wrapped to form the device.
- [0020] FIG. 19 shows a detail of the clinch member, illustrating radiopaque markers on the shunt rivet.
- [0021] FIGS. 20 and 21 illustrate a mandrel useful for forming and training/heat setting the shunt rivets.

[0022] FIG. 22 is a perspective view of a shunt rivet in which the clinch members are biased to provide a pair of clinch members biased to close upon contiguous parallel portions of adjacent vessels while exerting slight pressure on circumferentially spaced points on the side walls of the adjacent blood vessels.

[0023] FIG. 23 is a side view of the shunt rivet 22 showing the substantial closure of longitudinally oriented clinch members.

[0024] FIG. 24 is a side view of the shunt rivet 22 showing the preferred angle of the transversely oriented clinch members relative to the axis of the device.

[0025] FIG. 25 is a side view of the shunt rivet of FIG. 22 showing transversely oriented clinches.

[0026] FIG. 26 shows the shunt rivet of FIGS. 22 through 25 installed between an artery and a vein, illustrating the construction of the device relative to the environment of use.

[0027] FIG. 27 shows another variation of shunt rivet which may include varying lengths of the respective clinch members.

[0028] FIG. 28 shows a partial cross-sectional view of another variation of a shunt rivet as deployed having clinch members of differing lengths.

[0029] FIG. 29 shows a top view of another variation of a shunt rivet having an angled connector between the clinch members, which may also have differing lengths.

[0030] FIG. 30 shows a partial cross-sectional view of yet another variation of a shunt rivet having an angled connector which may also be tapered along its length.

[0031] FIG. 31 shows a partial cross-sectional view of yet another variation of a shunt rivet having hinges or flanges between the clinch members and the connector to adjust or change an angle between the shunt rivet and the vessels.

[0032] FIG. 32 shows a top view of another variation of a shunt rivet having one or more break-away or frangible segments which may be integrated with the shunt rivet along a periphery of the connector.

[0033] FIG. 33 shows a top view of another variation of a shunt rivet having one or more plastically deformable sections which may be integrated along the periphery of the connector.

[0034] FIG. 34 shows a partial cross-sectional view of yet another variation of a shunt rivet having plastically deformable, elastically deformable, or break-away segments or portions along a length of the connector to adjust a length of the lumen through which blood is shunted.

[0035] FIG. 35A shows a partial cross-sectional view of yet another variation of a shunt rivet illustrating an example of an ordered sequence in which the clinch members may be deployed.

[0036] FIGS. 35B and 35C illustrate side views, respectively, of clinch members of a shunt rivet being deployed entirely within a vessel.

[0037] FIG. 36 shows a side view of one variation of an instrument which may be used to adjust a length of the connector lumen.

[0038] FIG. 37 shows a side view of another variation of an instrument which may be used to adjust an angle of the shunt rivet with respect to the vessels.

[0039] FIG. 38 shows side and end views, respectively, of another variation of an instrument having an inflatable balloon which may be used to adjust a cross-sectional area of the shunt rivet to adjust the flow rate between the vessels.

[0040] FIG. 39 shows a top view of a shunt rivet having an oval cross-sectional area which may be optionally adjusted.

[0041] FIG. 40 shows a top view of another shunt rivet having a rectangular cross-sectional area.

DETAILED DESCRIPTION OF THE INVENTION

[0042] FIG. 1 illustrates the method of installing the shunt rivet to create and maintain an artificial aortocaval fistula. The patient 1 is shown with a delivery catheter 2 inserted into the left femoral artery/external femoral artery 3L and pushed upwardly through the left common iliac artery 4L to a point just above the aortic/iliac bifurcation in the distal abdominal aorta 5. The inferior vena cava 6 runs parallel to the aorta, and typically is contiguous with the aorta. As shown in the illustration, the left femoral artery provides a nearly straight pathway to a suitable site of the artificial aortocaval fistula 7 within the abdominal aorta (the right femoral vein 9R also provides a straight pathway to the same site on the vena cava side, and may be also be used as an access pathway). The fistula is created by forming a small hole or slit through the walls of both the aorta and the vena cava at immediately adjacent sites, and is maintained by inserting the shunt rivet 8 described below. The device may also be implanted via a route through the left femoral vein 9L, or through the right femoral artery 3R and/or right common iliac artery 4R, though these pathways are not expected to be so readily navigable. The shunt rivet may also be installed in an artificial arterio-venous fistula formed between the femoral vein

and femoral artery on either side of the body, indicated as items **10R** and **10L**, or between the iliac artery and the femoral vein, and at locations in the aorta above the renal arteries.

[0043] **FIG. 2** illustrates the aortocaval shunt rivet **8** in its restrained condition, while **FIG. 3** illustrates the aortocaval shunt rivet of **FIG. 2** in its resiliently expanded configuration. The shunt rivet may be formed from a single tube **11** of resilient material, such as nitinol, spring steel, glass or carbon composites or polymers, or pseudoelastic (at body temperature) material such as nitinol or comparable alloys and polymers, by laser cutting several closed-ended slots **12** along the length of the tube (leaving the extreme distal and proximal edges of the tube intact) and cutting open-ended slots **13** from the longitudinal center of the tube through the distal and proximal edges of the tube. The open-ended slots are cut between each pair of closed-end slots to form a number of loops **14** joined at the center section by waist segments **15**. Though the shunt rivet illustrated in these figures can be made of several loops of wire welded together at the waist section, and many other fabrication techniques, manufacture from a single tube as illustrated has been convenient.

[0044] After the tube is cut as described above, it is formed into its eventual resiliently expanded configuration illustrated in **FIG. 3**. In this configuration, the loops turn radially outwardly from the center section, and evert toward the center plane of the center section, thus forming clinch members **16** in the form of arcuate, everted, petaloid frames at either end of the loop, extending from the generally tubular center section formed by the waist segments **15**. For clarity, the term everted is used here to mean that the arc over which the petaloid frame runs is such that the inside surface of the device as configured in **FIG. 2** faces radially outwardly from the cylinder established by the tube. **FIG. 4** is a perspective view of the shunt rivet in the resiliently expanded configuration illustrated in **FIG. 3**, more clearly illustrating the relationship between the several petaloid frames at each end of the shunt rivet.

[0045] **FIG. 5** shows a side view of the aortocaval shunt rivet of **FIG. 2** in a fully expanded configuration. Even after the device has resiliently expanded to the extent possible given its impingement upon the walls of the aorta and the vena cava, the center section may be further expanded by plastic deformation. This may be accomplished by inflating a balloon within the center section, inflating the balloon, and expanding the center section beyond its elastic or superelastic deformation range. By plastically deforming the center section of the shunt rivet, the center section becomes more rigid and able to withstand the compressive force of the walls of the aorta and vena cava.

[0046] As illustrated, the construction provides several pairs of longitudinally opposed (that is, they bend to come into close proximity to each other, and perhaps but not necessarily, touch) and aligned (they are disposed along the same longitudinal line) distal and proximal petaloids. Overall, the petaloid frames of the distal section form a "corolla" (analogous to the corolla of a flower) flange or rivet clinch, which impinges on the vena cava wall and prevents expulsion into the aorta, and the petaloid frames of the proximal section form a corolla, flange or rivet clinch (this clinch would be analogous to a rivet head, but it is formed like the clinch after insertion of the rivet), which impinges on the aorta wall and prevents the expulsion of the shunt rivet into the vena cava, and the central section 17 forms a short length of rigid tubing to keep the fistula open. The resilient apposition of the two distal and proximal flanges or corollas so formed will securely hold the shunt rivet in place by resiliently clamping the walls of the aorta and vena cava (even over a considerable range of wall thickness or "grip range").

[0047] Referring to **FIGS. 2** through **5**, the shunt rivet may be manufactured with an overall initial length L of about 8 to 10 mm to obtain a grip range G of about 3 mm (given a typical aortic wall thickness of 2 mm and a typical inferior vena cava wall thickness of 1 mm at the target site), a clinch allowance C of at least about 3 mm (the clinch allowance is the distally protruding portion of a rivet that is turned over, curled or flattened to form the formed head), a formed or blind head allowance A of about 10-16 mm (we use the term blind head to refer to the distal head, which is the head that is formed on the blind side of the joint), a head diameter H of 5-16 mm, an initial shank diameter $D1$ of 3-8 mm (in the resiliently expanded configuration, prior to plastic deformation), a final shank diameter $D2$ of 5-12 mm to create a flow through lumen of about 5-10 mm diameter. The grip strength of the shunt rivet should provide for a slight compressive force exerted by the opposing clinch members on the intervening blood vessel walls. Thus, the shunt rivet is formed such that, in the resiliently expanded configuration, produces a grip strength in the range of 0.1 to 1.5 oz (about 3 to 45 gram-force) per clinch member upon the intervening blood vessels of the expected thickness.

[0048] **FIGS. 6** through **11** illustrate the method of releasing the shunt rivet so that the distal clinch members are released within the vena cava and the proximal clinch members are released within the aorta. Prior to insertion of the delivery catheter, the surgeon performing the implantation will image the aorta and inferior vena cava with appropriate fluoroscopic, ultrasonic, or other imaging methods, and create a pilot hole in the vessel walls with a crossing catheter. As shown in **FIG. 6**, the shunt rivet is housed

within the distal tip of a delivery catheter **23**, and is entirely restrained within the delivery catheter. The delivery catheter includes an outer sheath **24**, a shaft **25** which is longitudinally slidable within the outer sheath, and a tapered or rounded tip **26** disposed on the shaft. The tapered may be mounted on a separate shaft, slidably disposed within the shaft **25**, so that it may be pushed through the prepared aperture while holding the remainder of the device steady within the aorta. The distal edge of the outer sheath may also be rounded or tapered, as shown. A distally facing shoulder **27** on the shaft, just proximal to the shunt rivet, serves to keep the shunt rivet in place longitudinally as the outer sheath is withdrawn. A guide wire lumen **28** may be provided in the shaft for use with a guide wire **29**, and may extend to the proximal end of the shaft for over-the-wire operation or may exit the shaft just proximal to the shunt rivet holding segment for monorail guidewire operation, and other guide wire configurations may also be used. A balloon **30** may be disposed on the shaft (and a suitable balloon inflation lumen provided in the shaft, and a suitable inflation pressure source in fluid communication with the lumen).

[0049] As shown in **FIG. 7**, the distal tip of the delivery catheter is pushed through a small aperture in the walls of the aorta and vena cava (items **31** and **32**) (the aperture is made by the operator, using a separate or integral punch, needle or lance) to create the artificial aortocaval fistula. After the distal tip has entered the vena cava, the outer sheath is pulled proximally to release the distal petaloids, as shown in **FIG. 8**. After the distal petaloids have reverted to their unrestrained configuration, the entire device is pulled proximally to seat the distal petaloids against the inner wall of the vena cava. Prior to complete release of the shunt rivet, the operator should confirm that its location is acceptable (any suitable imaging technique may be used). To allow retraction in case the shunt rivet must be repositioned, a hook **33** protrudes radially from the shaft **25** and passes through a loop of the shunt rivet. This traps and secures the shunt rivet within the outer sheath **24** until the outer sheath is moved proximally to release the proximal clinch members, so that the operator may pull the shunt rivet back into the outer sheath in case its location, as visualized prior to complete release of the shunt rivet, is undesirable. Any other retaining means, such as a resilient or spring-loaded detent, a retractable pawl which engages a loop of the shunt rivet, of a retractable hook extending inwardly from the outer sheath, may be used in place of the illustrated hook.

[0050] Then the outer sheath is pulled further proximally to release the proximal petaloids, as shown in **FIG. 9**. With the shunt rivet securely set in the artificial fistula,

the center section may then be expanded by inflating the balloon as shown in **FIG. 10**. Upon withdrawal of the shaft, the shunt rivet remains in place to hold the two perforations in the blood vessel wall in apposition to each other to maintain the fistula, and to maintain an open shunt pathway between the aorta and vena cava, as shown in **FIG. 11**.

[0051] The final form of the shunt rivet is, according to the above description, accomplished with the method that includes forming the generally tubular structure having a central section with a first diameter, a proximal clinch section defined by one or more clinch members, and a distal clinch section defined by one or more clinch members, training the proximal and distal clinch members to make them resiliently biased to bend radially outwardly from the central section; then resiliently compressing the tubular structure to maintain a generally tubular shape and restraining the compressed tubular structure in a compressed configuration suitable for percutaneous insertion into the body; inserting the structure through apposing apertures in the aorta wall and vena cava wall of a patient such that the distal clinch members protrude into the vena cava of the patient and the central section is disposed within the apertures; and then releasing the distal clinch members to permit resilient expansion of the distal clinch members followed by expanding the central section through plastic deformation to larger diameter and releasing the proximal clinch members to permit resilient expansion of the proximal clinch members (the proximal clinch members may be released before or after expansion of the central section).

[0052] The shunt rivet illustrated above may be modified as shown in **FIGS. 12** and **13**, which show an aortocaval shunt rivet with asymmetrically shaped distal and proximal flanges. In **FIG. 12**, the shunt rivet **35** is similar to the shunt rivet of **FIGS. 2** through **4**, and includes the central section, the distal flange comprised of multiple petaloid wire-frame members **16d**, and the proximal flange comprised of multiple petaloid wire-frame members **16p**. In this embodiment, the distal corolla is horn-shaped, "salverform" or "funnelform" (as those terms are used in botany), with the petaloids arcing outwardly without everting (without a substantial arc in the proximal direction), while the proximal corolla is perianth-like, arcing outwardly and everting with a substantial arc in the distal direction. Each petaloid is significantly reflexed, like the perianth of a narcissus cyclamineus. **FIG. 13** illustrates another embodiment of the aortocaval shunt rivet with asymmetrically shaped distal and proximal flanges. In **FIG. 13**, the proximal petaloids are highly reflexed, and evert to form pigtails with an arc of over 180°, and preferably, as illustrated, an arc in excess of about 270°, such that the proximal petaloids bend radially

inwardly toward the tips **36** to present a length of wire **37**, rather than the tip of the petaloids, for impingement on the blood vessel wall. One or both of the distal or proximal petaloids/clinch members may be modified to form the pigtails illustrated in **FIG. 13**. In the embodiments shown, the petaloids are gamopetalous (with the petals united by their margins, at least at the base, as in **FIG. 2 et seq.**), but they may also be polypetalous as shown below **FIGS. 14, 15 and 16**. The embodiments shown are also actinomorphic, though they may be constructed in zygomorphic fashion with asymmetrical petaloids.

[0053] **FIGS. 14, 15 and 16** illustrate an aortocaval shunt rivet **8** with diamond shaped strut members in the central section. This shunt rivet provides a central section **17** with a series of expandable loops joined by circumferentially oriented struts **38**. **FIG. 14** illustrates a tube **11** with numerous slots cut into it to form the shunt rivet shown in **FIG. 16**. Slots **12** are closed-end slots, leaving a loop **14** extending from the central section **17** to form a clinch member cell **39**. Slots **40** are open or closed-end slots extending from the center of the device, leaving small circumferential struts **41** connecting adjacent cells of the device. Slots **42** are open or closed-end slots extending from the center section of the device, leaving larger waist sections **43** connecting the circumferential struts with adjacent clinch member cells of the device. Slots **44** are closed-end slots extending through the waist sections. As shown in **FIG. 15**, some waste area (segments intended to be removed) **46** shown in **FIG. 14** are cut away and discarded, leaving expandable waist section cells **47** and clinch cells **39**, interconnected by the circumferential struts **38**. Though the device is illustrated with three clinch members on each end, the number of clinch members formed in the shunt rivet may be varied. The waist section cells and clinch member cells, can, as shown at **48**, share struts which define contiguous cells. As shown in **FIG. 16** the waist section cells, when expanded, form the diamond shaped cells of the central section. The clinch member cells comprise petaloid cells which may be described as lanceolate (narrow and tapering to an apex (though the apex is preferably blunt)), or ovate (having a broad base and narrow tip) rather than reniform or orbicular. The tip of the petaloid is preferably obtuse, rounded or blunt. As can be appreciated from **FIG. 16** the clinch members may also be described as longitudinally extending wires which connect the longitudinally tips of adjacent waist section cells.

[0054] **FIGS. 17 and 18** illustrate an aortocaval shunt rivet **51** formed with a single wired wrapped to form the device. In this device, a single wire has been wrapped around a specially formed mandrel to form a number of clinch members **52** on one end of the

device and a number of clinch members **53** on the other end of the device. As illustrated, each clinch member is slanted relative to the radius of the device, and the wires forming the waist segment of the device are also oblique to the longitude of the device. As viewed from the top, each clinch member comprises a substantially circular arc, and the wire continues from the arc longitudinally toward the opposite end of the device, forming straight waist segment **54** where it runs substantially parallel to the long axis of the device until it arcs circumferentially away from the previous arc to form the clinch member on the opposite end, whereafter it loops around to extend retrograde relative to the circumference, forming waist segment **55** running obliquely relative to the long axis, and back toward the first end of the device until it curves again circumferentially forward to form the loop of the next clinch member circumferentially adjacent the first loop and longitudinally in line with the immediate previously formed clinch member on the opposite end of the shunt rivet, and continues in this fashion until the entire tubular structure of the device is achieved. In tracing its path, the wire may cross over one or more other portions of the wire.

[0055] **FIG. 19** shows a detail of the clinch member, illustrating radiopaque markers on the shunt rivet. A radiopaque marker may be provided in the form of a radiopaque rivet **61** disposed near the tip of the clinch member **16**, or it may be provided in the form of a wrapped coil of radiopaque wire or thread **62**. The radiopaque markers may be comprised of platinum, iridium, tantalum, barium sulfate or other radiopaque materials. Similar markers may also be applied to the waist section. The marker material may also be selected to enhance visibility under ultrasound imaging, magnetic resonance imaging, or other suitable imaging techniques.

[0056] **FIGS. 20** and **21** illustrate mandrels or dies useful for forming and training/heat setting the shunt rivets. As shown in **FIG. 20**, a two-part mandrel comprises a distal mandrel portion **63** and a proximal mandrel portion **64**. Each mandrel is shaped to correspond to the desired final shape of the shunt rivet and its clinch members. The mandrel portions are inserted into the tube, after it has been cut, so as to deform the device. Where the device is formed from a pseudoelastic material that must be heat set or trained, the mandrels are dimensioned to deform the device to its desired open configuration. Where the device is formed of spring steel or the like, the mandrel is dimensioned to bend the clinch members beyond the desired final configuration. Thus, the mandrel of **FIG. 20** and the mandrel of **FIG. 21**, though shaped differently, may be used to form quite similar shapes for devices made of nitinol and spring steel. The

mandrel shapes may be modified as desired to achieve various clinch member shapes, such as the asymmetrical shapes shown in **FIGS. 12** and **13**.

[0057] The shunt rivet may be modified as shown in **FIGS. 22** through **25**. **FIG. 22** is a perspective view of a shunt rivet **65** in which the clinch members are biased to provide pairs of clinch members **66a** and **66v** biased to close upon contiguous parallel portions of adjacent vessels and a pair of clinch members **67a** and **67v** biased to exert slight pressure, and establish slight compliance mismatch, on circumferentially spaced points on the side walls of the adjacent blood vessels. Each clinch member is slit down the center to allow radially expansion of the device through radial deformation of the clinch member.

[0058] **FIG. 23** is a side view of a shunt rivet of **FIG. 22** showing the substantial closure of longitudinally oriented clinch members **66a** and **66v**. These clinch members are formed to evert, such that the tips of opposing clinch members **66a** and **66v** are closely proximate each other when released (in the expanded configuration shown). A short segment at the distal tip of each clinch member is turned away from the transverse midline **68** of the device to form an atraumatic bearing surface for impingement on the blood vessels walls. As illustrated, the clinch members **66a** and **66v** comprise a continuously formed clip, with no intervening waist segment between the arterial portion of the clip and the venous portion of the clip. The clip resembles a tool clip, as that term is used in other arts. Preferably the clinch members making up the tool clip are joined directly together, without an intervening rectilinear base (though a rectilinear base may be incorporated if desired to accommodate the anatomy of the arterio-venous fistula in a particular site), to create a smoothly arcuate transition from the distal clinch member to the proximal clinch member. **FIG. 24** is a side view of the shunt rivet **22** showing the preferred angle of the transversely oriented clinch members **67a** and **67v** relative to the axis **70** of the device. In this embodiment, the transversely oriented clinch members **67a** and **67v** (both the near and far pairs are visible in this view) are set at a small angle from axis **70**. In the unrestrained configuration, the clinch members **67a** on the arterial side of the device (typically the first side of the device to be released from the catheter given the preference for transvenous delivery) are inclined toward the upstream or retrograde direction. Clinch members **67v** on the venous side of the device are inclined toward the upstream or retrograde direction within the vein. This configuration facilitates release of the device from the small delivery catheter used to insert it into a fistula.

[0059] FIG. 25 is a side view of the shunt rivet of FIGS. 22 through 24 showing transversely oriented clinch members 67a and 67b with substantial spacing between the tips of the clinch members (in the expanded configuration shown). Also, clinch members 67a and 67b constitute a continuously formed tension spring (shaped substantially like the tension spring used in window frames, having an arcuate or bow shape, with the ends arcing outwardly from the axial centerline 70 of the device and adapted to impinge upon or exert force on the blood vessels and the middle of the arch adapted to exert force on the remainder of the shunt rivet to which it is fixed), with no intervening waist segment between the arterial portion of the tension spring and the venous portion of the tension spring, and the tension spring formed to impinge on the sidewall of the artery or vein at a point circumferentially displaced from the center of the rivet without deforming the artery and/or vein walls to bring the opposite tips 69a and 69v into apposition such as that achieved by the tips of the tool clips. A short segment at the distal tip of each clinch member is turned away from the axial centerline 70 of the device to form an atraumatic bearing surface for impingement on the blood vessel walls.

[0060] The device may thus be described, in their open and unconstrained conditions, as comprising two parallel tool clips secured at their closed ends to two parallel tension springs, at the midpoints of the tension springs, to create an orthogonal or cruciform grouping of alternating spring clips and tension springs. Adopting the botanical language used for other embodiments, each side of the device comprises a pair of petaloids arcing outwardly from the axial centerline of the device without everting (without a substantial arc in the proximal direction), and a pair of petaloids arcing outwardly and everting with a substantial arc in the distal direction, with corresponding petaloid structures being joined at their proximal ends without an intervening waist segment. Each petaloid is formed in an open frame V-shape. Though illustrated with a pair of clips and a pair of tension springs, the device may be formed with additional tension springs or clips, as dictated by the local anatomy of a particular installation. In appropriate anatomical conditions, the device may comprise four clips in the tool clip configuration, or the comparable everting petaloid pairs (in which all clinch members evert substantially to close upon the vessel wall), arranged orthogonally, where the tool clips are arranged in a circular arrangement with the closed end of each clip being secured to the closed end of an adjacent clip, such that the open end of each tool clip is directed outwardly from the circular arrangement. The device may also include additional arcuate tension springs and/or tool clip portions,

thus departing from the cruciform configuration shown while achieving the benefit of substantial spacing of the vessel contacting tips from the arterio-venous fistula.

[0061] FIG. 26 shows the shunt rivet of FIGS. 22 through 25 installed between an artery 71 and vein 72, in order to illustrate the construction of the device relative to the environment of use. The tips of the "tool clip" portion of the device (66a and 66b) close upon points in the respective vessels 73a and 73v which are longitudinally spaced (relative to the blood vessels) from the arterio-venous fistula formed in which the device is placed. The points of impingement are significantly spaced from the fistula, as illustrated. The tips of the tension spring portion (67a and 67v) of the device impinge on circumferentially spaced points 74a and 74v. As shown in FIG. 26, the circumferential points of impingement are significantly spaced from the fistula. The circumferential spacing is preferably 30° to 90°, but may be adjusted to fit local anatomy. In this manner, the shunt rivet avoids engagement of the blood vessels adjacent the fistula. As shown in FIG. 26, the ultimate shape of the installed shunt rivet may vary from the unrestrained shape due to the remaining constraint of the blood vessel walls, though the device is biased to resiliently or superelastically return to the unrestrained shapes of FIGS. 22 through 25. After installation, the shunt rivet holds the adjacent artery and vein together and maintains an open flow path through opening defined by the roughly circular arrangement of the clips and tension springs. Should the arrangement appear to be somewhat squared or angular, pentagonal, hexagonal, etc., given the particular geometries of the various parts, it is intended that such departures from perfect circular arrangement be included under the description of a circular arrangement.

[0062] Yet another variation for the shunt rivet may include varying a length of the respective clinch members. As illustrated in the perspective view of Fig. 27, shunt rivet 80 may include the longitudinally oriented clinch members 81a, 81a' and 81v, 81v' positioned opposite to one another and transversely oriented clinch members 82a and 82v positioned transverse relative to an axial centerline of shunt rivet 80, as described above. In this variation, clinch members 81a and 81v' may be sized to have a length which is less than clinch members 81a' and 81v, as described in further detail below. The respective lengths of clinch members 81a, 81v' relative to 81a', 81v may be variably sized to maximize or optimize the stability of shunt rivet 80 with respect to the vessels when deployed between adjacent vessels.

[0063] Moreover, varying the lengths of the respective clinch members may further provide additional advantages. For instance, the clinch members which are shortened in

length may facilitate the positioning and securement of the shunt rivet between the vessels by allowing for the relatively shorter member to swing into position within the vessel lumen during deployment, as described in further detail below. Moreover, a shorter member may provide for a minimized implant size when placed against the vessel interior wall for securement as well as a mitigating any physiologic reaction to the implant, e.g., a reduction in thrombosis, etc. Additionally, clinch members which are lengthened relative to other members may provide for increased shunt stability by increase the amount of force applied against the tissue walls.

[0064] Moreover, clinch members having different lengths may additionally place the adjacent vessels in tension such that the vessel walls are drawn towards one another and the clinch members **81a**, **81a'** and **81v**, **81v'** contact the vessel luminal walls to stabilize not only the shunt rivet within the vessels but also the vessels with respect to one another. Additionally, having one or more clinch members **81a**, **81v'** sized to have a length shorter than its respective apposed clinch member may also facilitate the deployment and/or positioning of the clinch members **81a**, **81v'** within the vessel since the shorter length clinch members can more easily "swing" through an arc within the vessel lumen without contacting the interior walls. Clinch members with differing lengths may further be configured to align along different planes when deployed to facilitate vessel separation, if so desired.

[0065] As above, each of the clinch members may be formed without an intervening waist segment between the arterial portion of the shunt rivet **81a**, **81a'** and the venous portion of the shunt rivet **81v**, **81v'**. As also previously described, the clinch members may be joined directly together, without an intervening rectilinear base (though a rectilinear base may be incorporated if desired to accommodate the anatomy of the arterio-venous fistula in a particular site), to create a smoothly arcuate transition from the distal clinch member to the proximal clinch member.

[0066] Aside from the variable length clinch members, shunt rivet **80** may further define one or more slots **83** along the length of the clinch members, such as at the terminal ends of each clinch member. The one or more slots **83** may be formed or cut, e.g., by a laser, to provide a region through which a radio-opaque marker or wire, such as tantalum wire or any other radio-opaque material as described herein, may be passed through to facilitate imaging during deployment. Shunt rivet **80** may also further include an optional radio-opaque center marking band about the center of rivet **80** to indicate the center, e.g., when viewed under fluoroscopy or any other imaging modality.

Additionally, one or more of each clinch member may also optionally include a slot **84** defined along a length of the individual respective clinch member struts, as shown, to further function as a stress-relieving slot.

[0067] Although shunt rivet may be formed without an intervening waist member, it may be optionally included. As shown in the illustrative partial cross-sectional view of Fig. 28, another variation of shunt rivet **93** may be seen deployed between two respective vessels, artery **90** and vein **91**. Clip connector **99** may extend between sets of clinch members **95, 96** and **97, 98** while defining lumen **94**. Although the transverse clinch members have been omitted from the illustration for clarity, they may be optionally omitted from the shunt rivet entirely, if so desired. In its deployed configuration when placed through fistula **92** defined between vessels **90, 91**, lumen **94** may define a flow path between the vessels, as described above. In this variation, clinch members **96, 97** are shortened in length relative to the lengths of clinch members **95, 98**. The shortened clinch members **96, 97** may be configured to be deployed on opposite ends of the shunt rivet such that shortened clinch member **96** is disposed within artery **90** while shortened clinch member **97** is disposed within vein **91** and extends in a direction opposite to that of clinch member **96**. Shortened clinch members **96, 97** may be similar in length and configuration or they may be varied in length relative to one another.

[0068] Likewise, clinch member **95** may be disposed in artery **90** while clinch member **98** is disposed in vein **91** such that they extend in opposing directions and are positioned opposite to their respective shortened clinch members. Like their shortened counterpart members, clinch members **95, 98** may be similar in length and configuration or they may also be varied in length relative to one another. Clinch members with differing lengths may be utilized in any of the variations described herein in combination with additional features, as described.

[0069] In addition to having clinch members of different lengths, the connector member itself may be modified such that it extends between the respective clinch members at an angle relative to a centerline of the shunt rivet, as illustrated by angled connector **100** in the top view of Fig. 29. The angled connector **100** may be configured over a number of various angles such that the blood flow between the vessels **90, 91** through angled connector **100** avoids a 90° turn.

[0070] In yet another variation, angled connector **110** may be further modified such that the cross-section of the connector is tapered along its length, as shown in the partial cross-sectional view of Fig. 30. Accordingly, in addition to having clinch members of

various lengths and an angled connector, the connector **110** and/or connector lumen **94** may be tapered or it may define a non-constant cross-sectional area along its length. For instance, the connector lumen **94** may be tapered such that the cross-sectional area increases as the connector **110** extends from the arterial vessel **90** to the venous vessel **91**, as shown. Alternatively, the cross-sectional area may decrease as the connector **110** extends away from the arterial vessel **90**.

[0071] In yet a further variation, the shunt rivet may optionally include a hinge or flange **111** connecting one or more of the clinch members to the connector **110**, as shown in Fig. 31. Such a hinge or flange may be adjustable to change an angle at which connector **110** extends between the clinch members and may utilize any number of hinging mechanisms. For instance, hinge or flange **111** may simply comprise a plastically deformable portion of the shunt rivet or it may be a mechanically hinged mechanism, e.g., which provides for frictional engagement between the clinch members and the connector **110** to maintain its position yet also allows for adjustment. The hinge or flange **111** may be adjusted prior to deploying the shunt rivet such that the clinch members extend at their predetermined angle when deployed. Alternatively, hinge or flange **111** may be adjusted during deployment or after the shunt rivet has been placed between the vessels **90**, **91** by using an inflatable balloon instrument or other expandable tool. In yet another alternative, the hinge or flange **111** may be adjusted both before deployment and during or post deployment into the vessels. For example, post deployment adjustments may be accomplished anytime, e.g., within one hour of shunt deployment, or alternatively in a subsequent procedure, e.g., prior to or after thirty days of deployment within a patient.

[0072] Another variation may utilize one or more break-away or frangible segments **120** which may be integrated with the shunt rivet along a periphery of connector **99**, as illustrated in the top view of Fig. 32. In this example, two break-away segments **120** may be integrated on either side of connector **99** such that when the shunt rivet has been positioned or during positioning into the vessels, connector **99** may be adjusted in size, e.g., by expanding the opening via a balloon instrument, to allow for a greater flow through the shunt rivet. The break-away segments **120** may be comprised of a number of different biocompatible materials which may be dissolved into the blood or they may be configured as opposing portions of connector **99** which are overlapped or otherwise held temporarily to one another.

[0073] Alternatively, segments **120** may be comprised of plastically deformable bands which break apart to adjust or allow for the adjustment of the cross-sectional area of the connector **99**. The adjustability of the connector cross-section may allow for the shunt rivet to change from a circular cross-sectional area to an oval cross-sectional area. In the same manner, the cross-sectional area may be changed from an oval area to a round area. The adjustment of the cross-sectional area utilizing the break-away segments **120** may be performed pre-implantation, during implantation, or post implantation of the shunt rivet into the vessels.

[0074] Another variation is shown in the top view of a shunt rivet in Fig. 33 which utilizes one or more plastically deformable sections **130** which may be integrated along the periphery of connector **99**. As shown, the plastically deformable sections **130** may be plastically deformed, e.g., via an inflatable balloon, either prior to, during, or post deployment to adjust the cross-sectional area of connector **99**. Moreover, plastically deformable sections **130** may be integrated into connector **99** such that when connector **99** is expanded or deformed, sections **130** plastically deform and retain their deformed configuration when a deforming force is removed.

[0075] Aside from variations in adjusting the cross-sectional flow area of the shunt rivets, other optional variations may be incorporated in any of the shunt rivets described herein. For instance, Fig. 34 shows a partial cross-sectional side view of yet another variation which may utilize plastically deformable, elastically deformable, or break-away segments or portions **140** along a length of connector **110** to adjust a length of the lumen through which blood is shunted. The portions **140** may be utilized along a length of connector **110** to allow for adjustment of the distance between the vessels **90**, **91** and they may be utilized with a connector length which is uniform in diameter or which is tapered or narrowed, as described above.

[0076] In utilizing a shunt rivet having different clinch member lengths, shorter length clinch members can more easily "swing" through an arc within the vessel lumen without contacting the interior walls, as mentioned above. Accordingly, such a shunt rivet may be implanted such that the clinch members are deployed in an ordered sequence. In one example, once a needle has been passed through the tissue wall to cross between vessels **90**, **91**, guidewire **30** may be advanced intravascularly through the needle which may then be removed leaving guidewire **30** passing through vessels **90**, **91**. Shaft **25** and/or outer sheath **24** may be advanced through vessel **90** over or along guidewire **30** to follow guidewire **30** into vessel **91**, as shown in Fig. 35A. Shaft **25**, described above,

may be fabricated with a stiffened tip, such as polyimide, to facilitate crossing between vessels. Once properly positioned within vessel **91**, outer sheath **24** may be pulled proximally while tracking its distal end visually via a marker band **152** until clinch member **98** is first released from the constraints of outer sheath **24** and allowed to reconfigure itself into its angled configuration, relative to a longitudinal axis of the shunt rivet. The individual clinch members of the shunt rivet may be optionally retained via anchoring pins **153** integrated with shaft **25** which may hold the clinch members in place as outer sheath **24** is retracted. These anchoring pins **153** may also serve to prevent or limit the motion of the shunt rivet itself until outer sheath **24** has been fully retracted. This particular configuration may be utilized in situations where a clinician may wish to re-sheath the shunt rivet, e.g., for abandoning a procedure or for repositioning the shunt rivet, etc.

[0077] With outer sheath **24** pulled further proximally, shortened clinch member **97** may be subsequently released. With its shortened length, relative to clinch member **98**, clinch member **97** may fully deploy and arc **151** entirely within vessel **91** without interfering or contacting the distal region of the vessel wall until clinch member **97** comes into contact against the proximal region of the vessel wall. With clinch members **97**, **98** fully deployed within vessel **91**, outer sheath **24** may be further withdrawn relative to shaft **25** to subsequently release shortened clinch member **96**, which may then arc **150** entirely within adjacent vessel **90** to contact the tissue surrounding the fistula. Subsequently, outer sheath **24** may be fully retracted to release clinch member **95** to allow it to come into contact against the tissue wall within vessel **90**, thereby fully deploying the shunt rivet between vessels **90**, **91**. The shunt rivet may be partially deployed from shaft **25** and optionally removed and/or re-positioned and re-deployed elsewhere within the body.

[0078] Another example is illustrated in Figs. 35B and 35C, which illustrate side views of clinch members of a shunt rivet being deployed entirely within a vessel. As shown in Fig. 35B, once the assembly has been advanced intravascularly through vessel **90**, e.g., an artery, and the needle and guidewire advanced from within vessel **90** and into adjacent vessel **91**, e.g., a vein, shaft **25** carrying the shunt rivet may be advanced at least partially from outer sheath **24** (alternatively, outer sheath **24** may be retracted relative to shaft **25**) to expose the transversely oriented clinch members **154**, **156** and the clinch members **97**, **98** for expansion and/or reconfiguration within vessel **91**. As shown, clinch member **97** may reconfigure from a low profile configuration where clinch member **97** is

positioned to extend distally along shaft **25** during delivery to a configuration where member **97** swings proximally within vessel **91**, as shown, to a securement configuration.

[0079] One or more members can be deployed and by advancing the outer sheath **24** (and/or retracting shaft **25** relative to outer sheath **24**), the members can be recaptured and at least partially re-sheathed to allow for removal and/or repositioning of the shunt rivet. Once desirably repositioned, the clinch members may be fully deployed into position.

[0080] As further illustrated in this example, the lengthened clinch member **98** may engage against the vessel wall within vessel **91** during deployment. If excessive pull force is applied to the shunt rivet, member **98** can deform and straighten while deflected by the walls of vessel **91**, as illustrated by deformed tissue **158**, so as to prevent or inhibit damage to the surrounding tissue. A clinician can visually assess, e.g., via fluoroscopy or ultrasound, the wall-to-shunt engagement by gauging the amount of deflection indicated by the lengthened clinch member **98**. Along with the tactile feedback perceived by the clinician, the visual indication of the clinch member deformation may further aid in confirming suitable shunt rivet positioning.

[0081] Once the position of the shunt rivet has been confirmed within vessel **91**, clinch member **98** may be fully deployed and clinch member **97** may be fully deployed to swing proximally into its securement position within vessel **91**, as shown in Fig. 35C. The remaining clinch members may be subsequently released from outer sheath **24** and shaft **25** to be deployed within vessel **90**.

[0082] In delivering and configuring the shunt rivets described above, additional delivery instruments may be utilized to facilitate adjustment of the shunt rivets to a desirable configuration. For instance, adjusting the cross-sectional area of the connector portion of the shunt rivet or adjusting a length of the connector lumen between the clinch members, or adjusting an angle of the shunt rivet and clinch members with respect to the vessel lumens, etc., may be accomplished with instruments as shown in Figs. 36 to 38.

[0083] Fig. 36 illustrates one variation of an instrument **160** which may be used to adjust a length of the connector lumen. Instrument **160** may generally comprise an outer sheath **161** having an inflatable balloon or expandable member **162** disposed around a distal portion of the sheath **161**. Inner sliding core **163**, upon which the shunt rivet may be disposed upon or over, may be slidingly disposed within outer sheath **161** and may also have an inflatable balloon or expandable member **164** also disposed around a distal portion of core **163**. As mentioned above, with the shunt rivet disposed upon sliding core **163**, inflatable members **162**, **164** may be expanded to temporarily engage the respective

clinch members to lengthen or extend the connector length between the clinch members of the shunt rivet, e.g., to accommodate vessel separation distances, either prior to, during, or post implantation of the shunt rivet within the vessels. Alternatively, with members 162, 164 expanded, the connector length may be shortened between the clinch members.

[0084] The ability to adjust the length of the connector may allow for not only accommodating for the distance between the vessels, but also to “fine-tune” a flow rate of the blood through the shunt rivet to achieve a desired therapeutic result and/or to mitigate any side effects of the fistula. Moreover, although the adjustment to the shunt rivet may be done intra-operatively *in vivo*, adjustments may also be performed prior to insertion within the patient body. Moreover, an electronic or mechanical gauge or markers (such as visual markings or radio-opaque markers) may be integrated with the instrument 160 to provide feedback to the user as to the length that the shunt rivet is shortened or lengthened.

[0085] An example of another instrument which may be used to adjust an angle of the shunt rivet with respect to the vessels is shown in Fig. 37. As above, an inner sliding core 163 may be translatably positioned within outer sheath 161. A pullwire 165 may have a fixation point 166 near or at a distal end of sheath 161 and may be routed through outer sheath 161 and articulated 169 to adjust an angle of outer sheath 161 with respect to a longitudinal axis of sheath 161. Likewise, inner core 163 may also have a separate pullwire 167 with a fixation point 168 near or at a distal end of inner core 163 to adjust 169' its angle with respect to a longitudinal axis of inner core 163. Sliding core 163 and outer sheath 161 may both be articulated independently of one another to create multiple bending configurations. In this manner, a shunt rivet disposed within outer sheath 161 and/or upon sliding core 163 may be bent or curved into various configurations by the forces imparted upon the shunt rivet to adjust its angle with respect to the clinch members and vessels.

[0086] Such an instrument may be utilized to adjust not only an angle of, e.g., connectors between the clinch members, but also the hinge or flange 111 as well as other portions of the shunt rivet variations described herein. Moreover, the instrument may be utilized to plastically deform the portions of the shunt rivet. One or more radio-opaque markers may be included on the instrument to visually indicate an angle of the instrument. An additional and/or alternative variation may further include an instrument which is used to deform the tissue neighboring the fistula site in the same manner as

adjusting angles, distances, etc., of the shunt rivet. The shunt rivet may also be plastically deformed or it may be simply elastically deformed to accommodate the tissue shape changes. Additionally, the instrument may further include a mechanical or electronic gauge to indicate the degree of force imparted on the shunt rivet as well as relaying other information during or post deployment.

[0087] Yet another feature of a deployment instrument is shown in the partial cross-sectional side and end views, respectively, in Fig. 38. As shown, inflatable end effector 170 may include an inflation balloon 173 in fluid communication with an inflation lumen 172 which is disposed near or at a distal end of a delivery shaft 171. A shunt rivet may be disposed proximate to, upon, or distal to inflation balloon 173 in its deflated state for delivery into the vessels. Prior to, during, or post deployment of the shunt rivet into the vessels, inflation balloon 173 may be inflated to adjust a cross-sectional area of the shunt rivet to adjust the flow rate between the vessels, e.g., up to 5 mm or more diameter and as described above in the shunt rivet variations. Inflation balloon 173 may be configured to have a circular cross-sectional area such that expansion within the shunt rivet may adjust the shunt to have a corresponding circular cross-sectional area. Alternative variations of the inflation balloon 173 may include balloons having non-circular cross sections, e.g., such as an oval cross section with adjustable major and/or minor axes, as shown in the end view of Fig. 38, to optionally adjust a shunt rivet cross section accordingly. Other non-circular cross-sectional areas may be utilized, e.g., polygon, trapezoid, triangle, rhombus, rectangle, square, parallelogram, etc., to optimize a flow through the fistula and to vary or optimize an effective flow diameter through the shunt rivet and between the interconnected vessels.

[0088] Fig. 39 illustrates a top view of a shunt rivet having an example of an oval cross-sectional area 180, which may be optionally adjusted via the one or more instruments above. Another non-circular cross-sectional area is illustrated in Fig. 40, which shows a top view of a shunt rivet having a rectangular cross-sectional area 181. As mentioned, other non-circular cross-sectional areas (e.g., polygon, trapezoid, triangle, rhombus, rectangle, square, parallelogram, etc.) may be utilized to optimize flow conditions and/or therapeutic results for implantation between the vessels, as desired.

[0089] The devices described above may be provided with coatings or additional structures which serve as matrices for various therapeutic compounds. Drug eluting coatings, additional drug eluting strut members, drug eluting membranes surrounding the central section or drug eluting masses filling the cells of the device may be added to the

devices. For the aortocaval application and the arterio-venous application, therapeutic agents such as heparin and other anti-coagulants and paclitaxol, rapamycin (Sirolimus™), everolimus and other anti-stenotic compounds can be applied to the stent in polymer matrices which permit elution of these drugs over a period of time ranging from several hours to several months after implantation. Polymers such as polyurethane can be used as the matrix.

[0090] While the preferred embodiments of the devices and methods have been described in reference to the environment in which they were developed, they are merely illustrative of the principles of the inventions. Modification or combinations of the above-described assemblies, other embodiments, configurations, and methods for carrying out the invention, and variations of aspects of the invention that are obvious to those of skill in the art are intended to be within the scope of the claims.

CLAIMS:

1. An intravascular connector, comprising:

a first pair of clinch members comprising a first member and an apposed second member;

a second pair of clinch members opposite from the first pair of clinch members and comprising a first member and an apposed second member;

wherein the first and second pairs of clinch members has a deployed configuration longitudinally disposed relative to contiguous portions of a first vessel and a second vessel such that the first and second pairs of clinch members are biased to close upon contiguous parallel portions of the first and second vessels,

wherein the first member of the first and second pair of clinch members each have a length less than each second member of the first and second pair of clinch members such that each first member is deployed on opposite ends of the connector within the first and second vessels, respectively, and each individual clinch member is deployable sequentially in a predetermined order within the first vessel and second vessel, and

wherein each first member is sized to arc entirely within each respective vessel into its deployed position when each second member contacts each respective vessel wall.

2. The connector of claim 1 further comprising at least a third pair of clinch members having a deployed configuration transverse to the first and second pairs such that the third pair of clinch members are biased to exert a nominal pressure on circumferentially spaced points on side walls of the first and second vessels.

3. The connector of claim 1, wherein each second member of the first and second pair of clinch members are deployed on opposite ends of the connector within first and second vessels, respectively.

4. The connector of claim 1 further comprising a clip connector extending between the first and second pair of clinch members and defining a lumen therethrough fluidly coupling the first and second vessels.

5. The connector of claim 4, wherein the clip connector is angled relative to a centerline of the connector.
6. The connector of claim 4, wherein the clip connector defines a tapered cross-sectional area along its length.
7. The connector of claim 4, wherein the clip connector is angled relative to a centerline of the connector and defines a tapered cross-sectional area along its length.
8. The connector of claim 4 further comprising at least one deformable segment along a length of the clip connector.
9. The connector of claim 1 further comprising a hinge or flange between clinch members.
10. The connector of claim 1 further comprising at least one break-away or frangible segment along a periphery of the connector.
11. The connector of claim 1 further comprising at least one deformable segment along a periphery of the connector.
12. The connector of claim 1 further comprising a delivery instrument having an outer sheath and an inner shaft slidable within the outer sheath such that the connector is deployable from within the outer sheath.
13. The connector of claim 12 further comprising an inflatable member near or at a distal end of the outer sheath and/or inner shaft.

14. The connector of claim 12, wherein the outer sheath and/or inner shaft are articulatable.
15. The connector of claim 12, wherein the delivery instrument further comprises an inflatable balloon thereupon.
16. The connector of claim 15, wherein the balloon defines a circular cross-sectional area when inflated.
17. The connector of claim 15, wherein the balloon defines a non-circular cross-sectional area when inflated.
18. The connector of claim 1, wherein the first and second pairs of clinch members are biased to evert such that a distal portion of each apposed member is proximate to one another when released in its deployed configuration.
19. The connector of claim 1, wherein a distal portion of each apposed clinch member is configured to form an atraumatic bearing surface therebetween for impingement on the first and second vessels.
20. The connector of claim 1, wherein the first and second pairs of clinch members comprise a continuously formed clip absent an intervening waist segment.
21. The connector of claim 1, wherein the first vessel comprises an artery.
22. The connector of claim 1, wherein the second vessel comprises a vein.
23. The connector of claim 2, wherein the third pair of clinch members each define a distal portion which is spaced apart from one another in the deployed configuration.

24. The connector of claim 2, wherein the third pair of clinch members comprise a continuously formed clip absent an intervening waist segment.

25. The connector of claim 1 further comprising a therapeutic drug coating or membrane at least partially covering the connector.

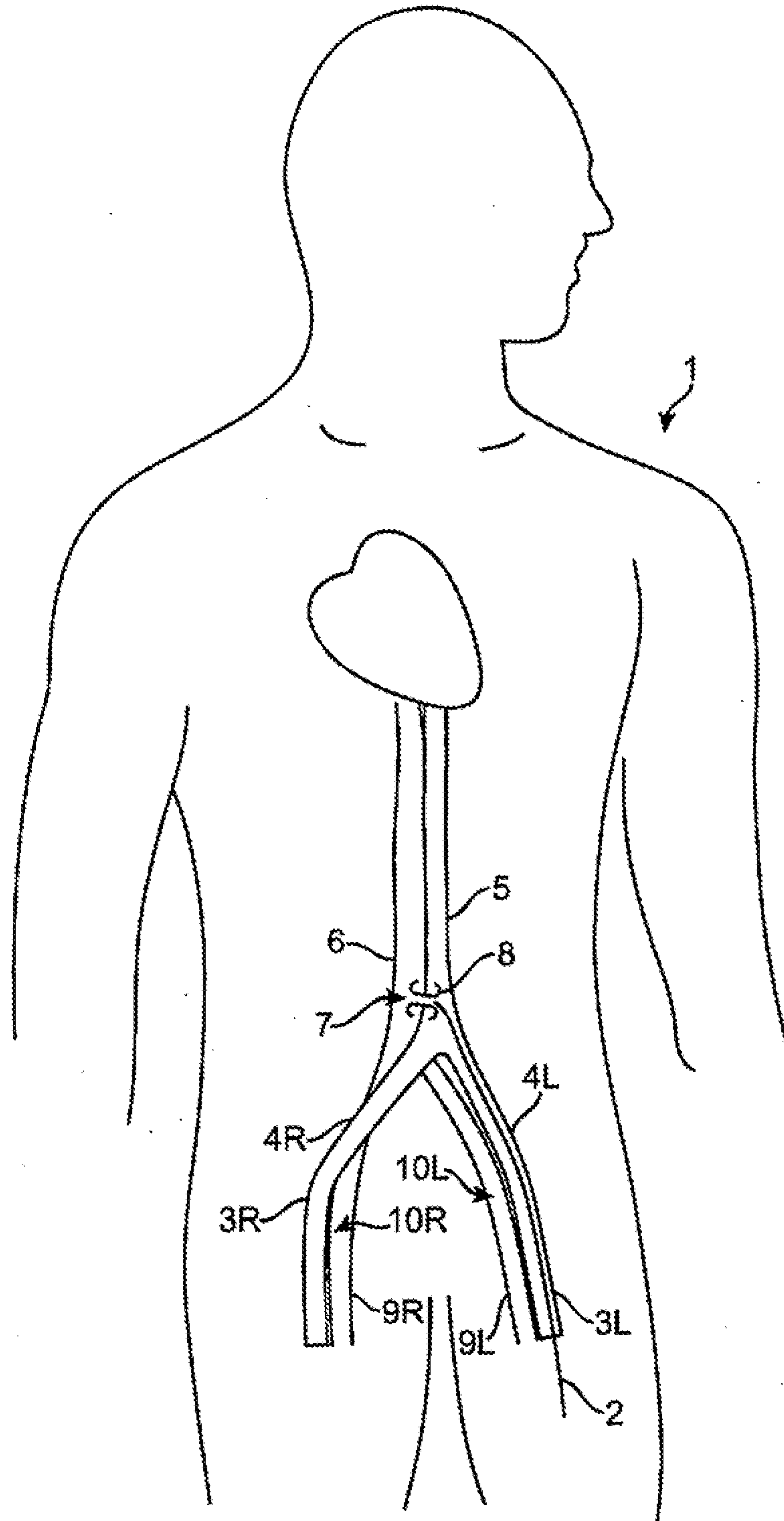

FIG. 1

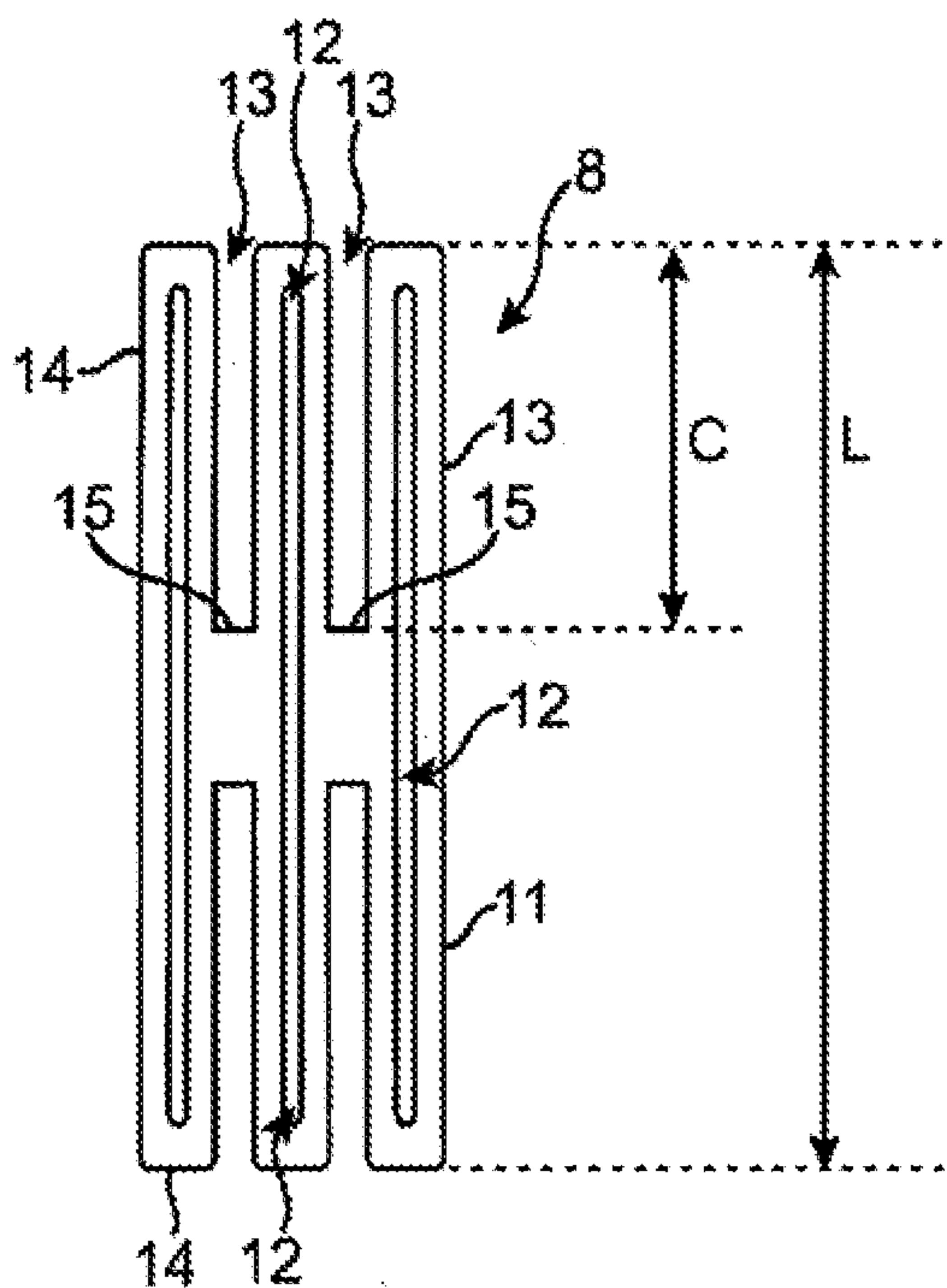

FIG. 2

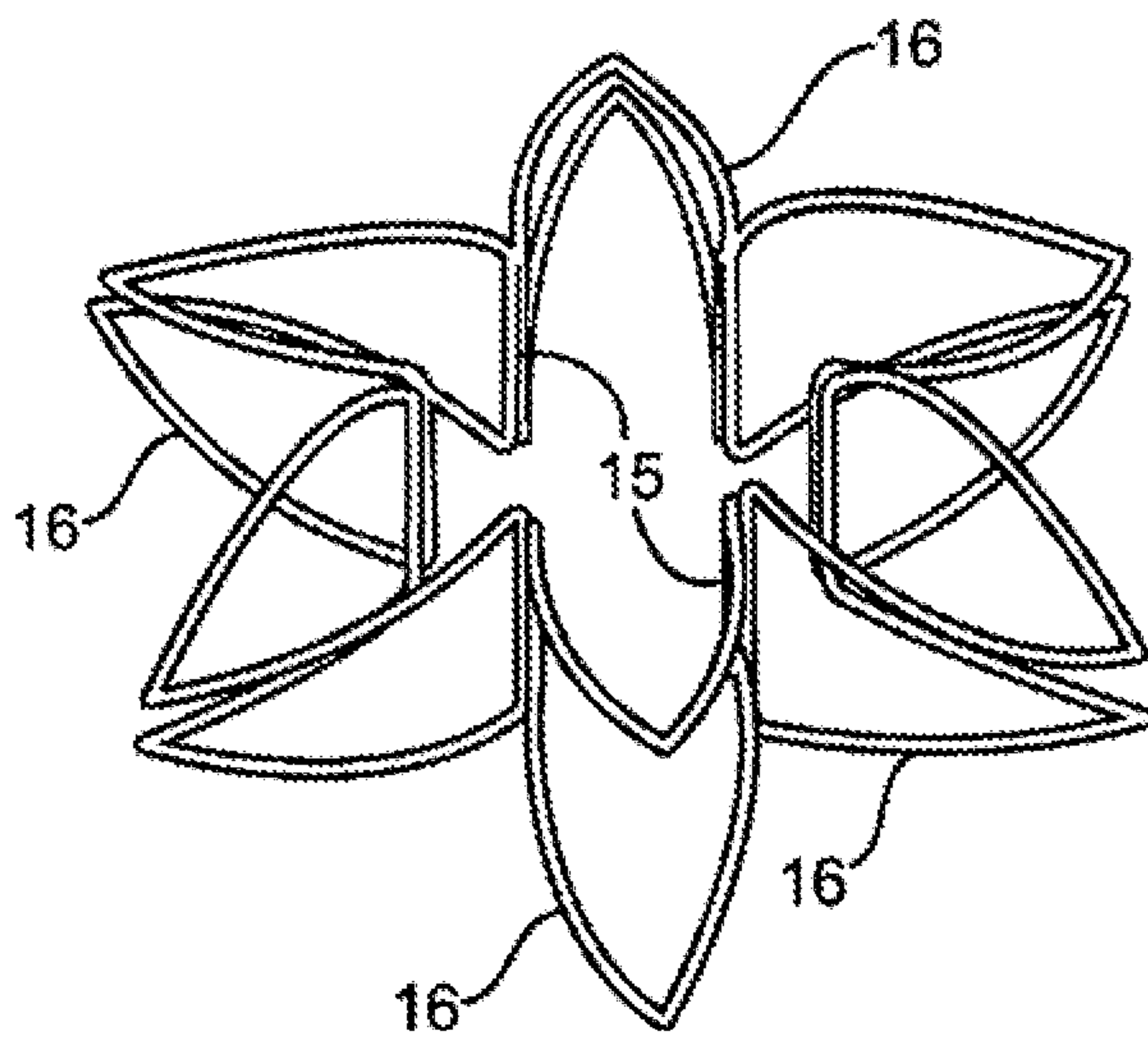

FIG. 4

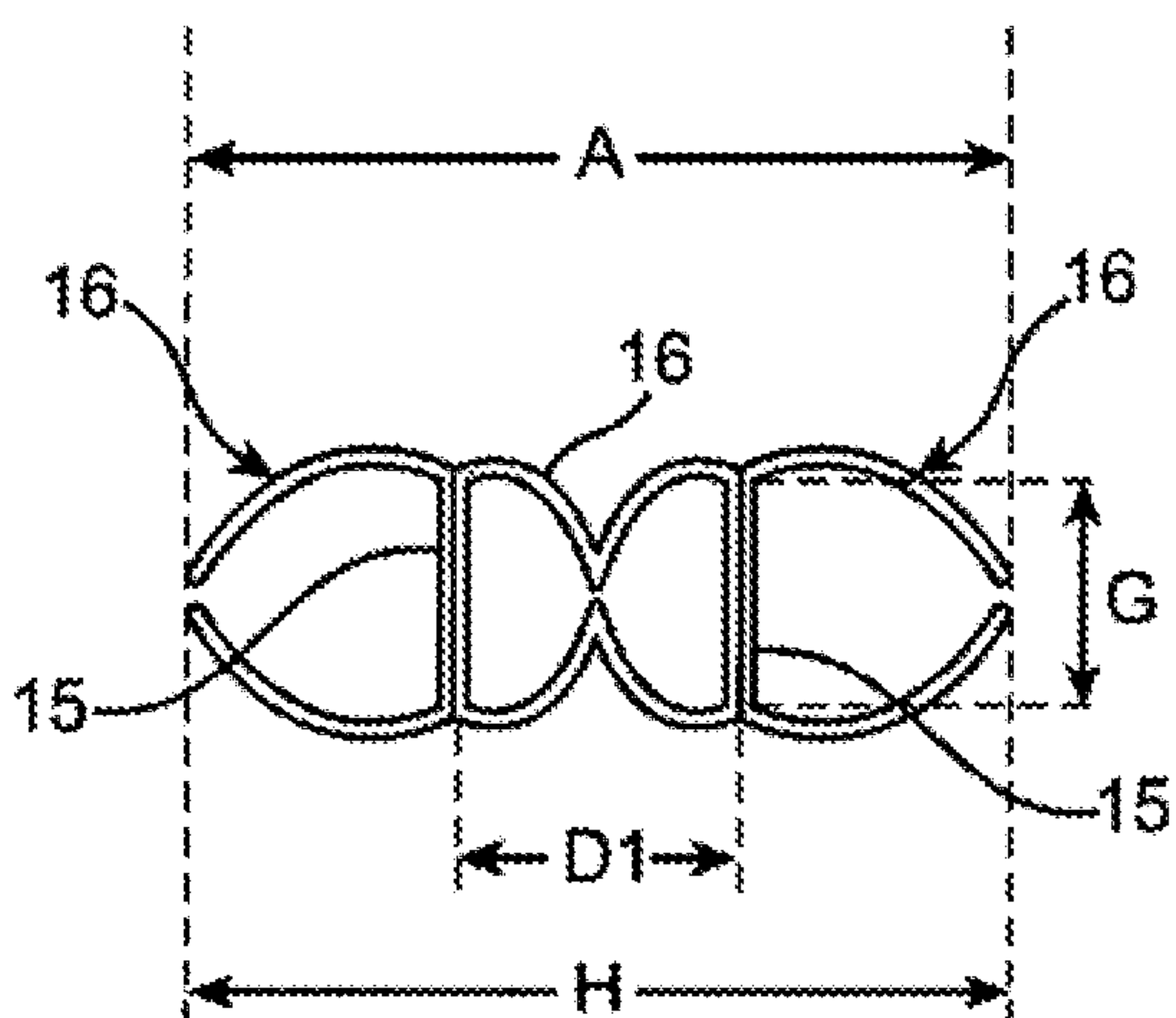

FIG. 3

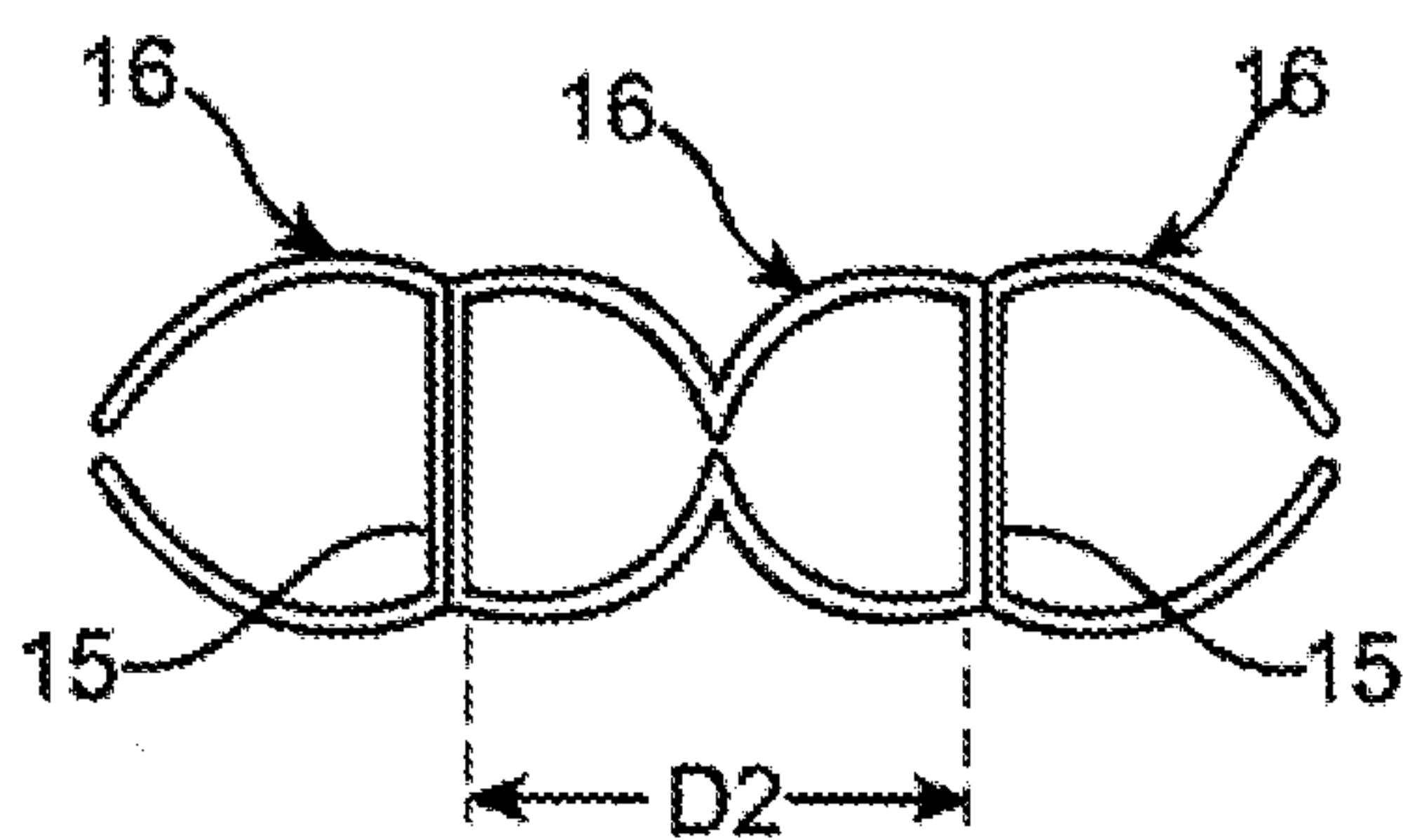

FIG. 5

3 / 19

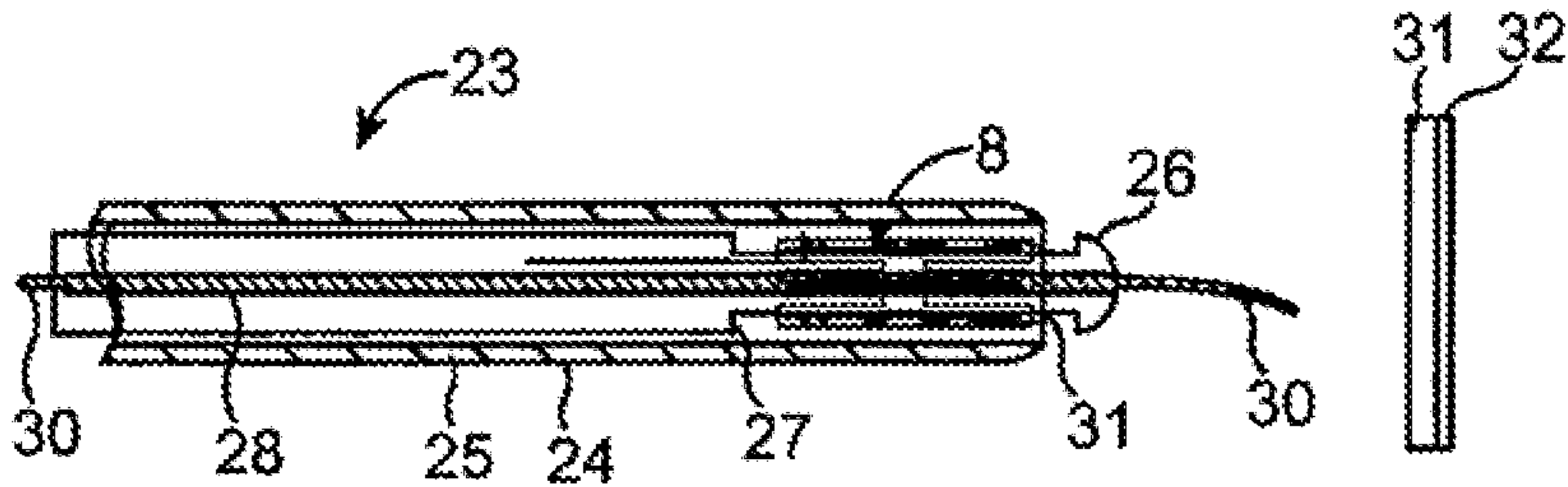

FIG. 6

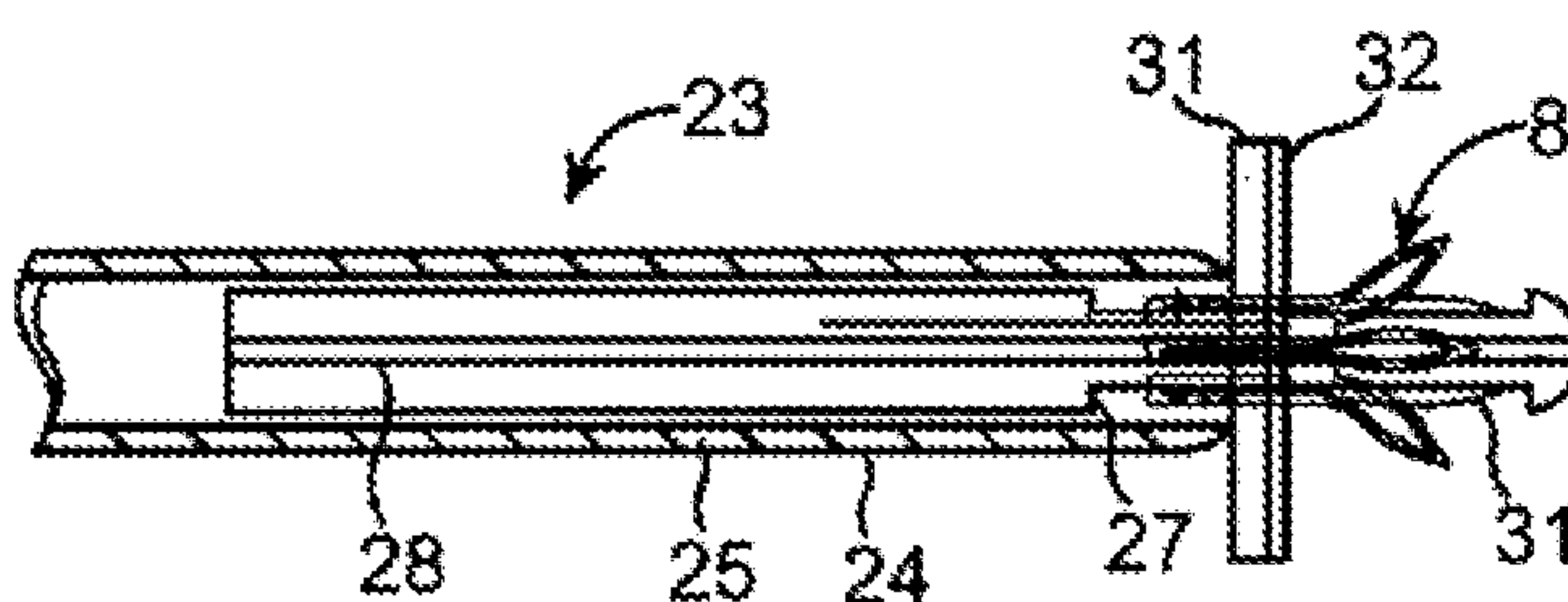

FIG. 7

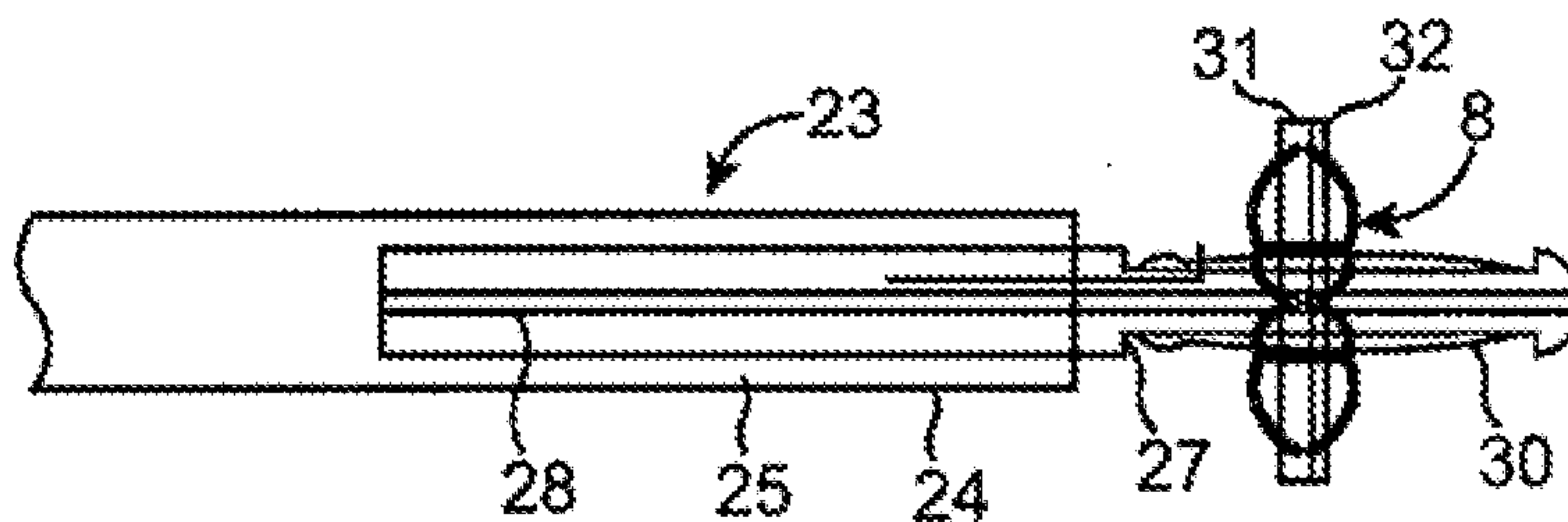

FIG. 9

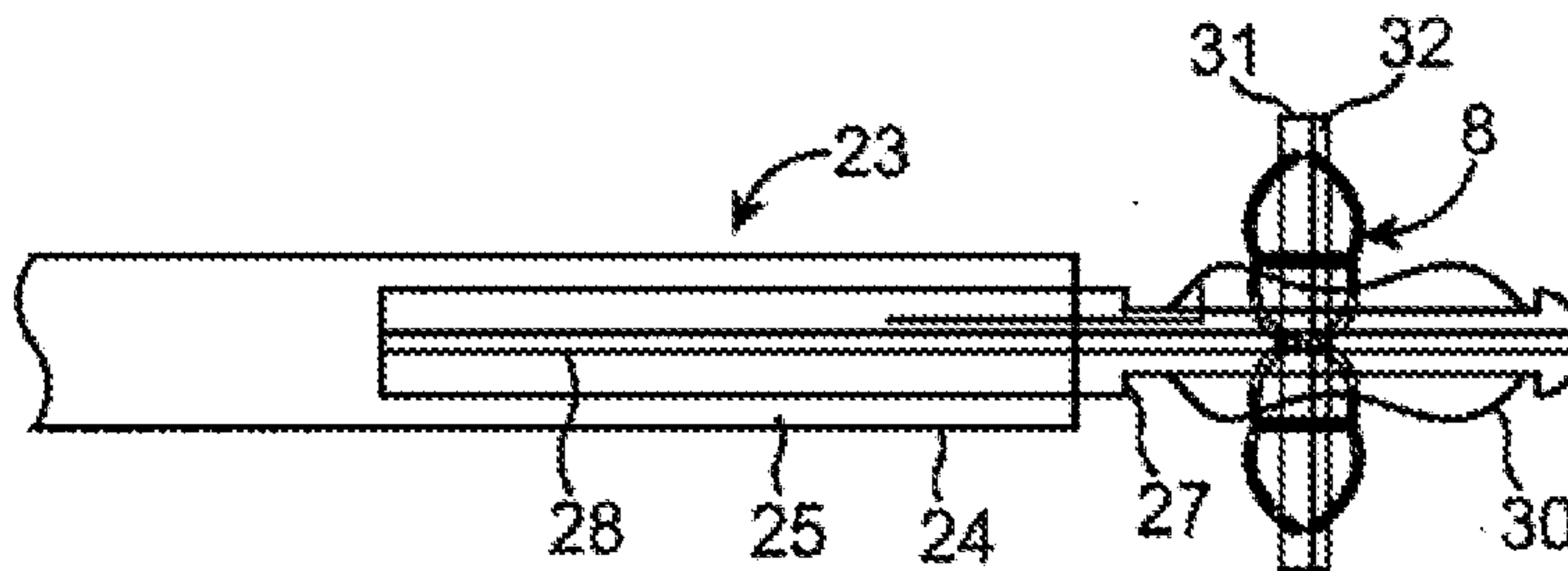

FIG. 10

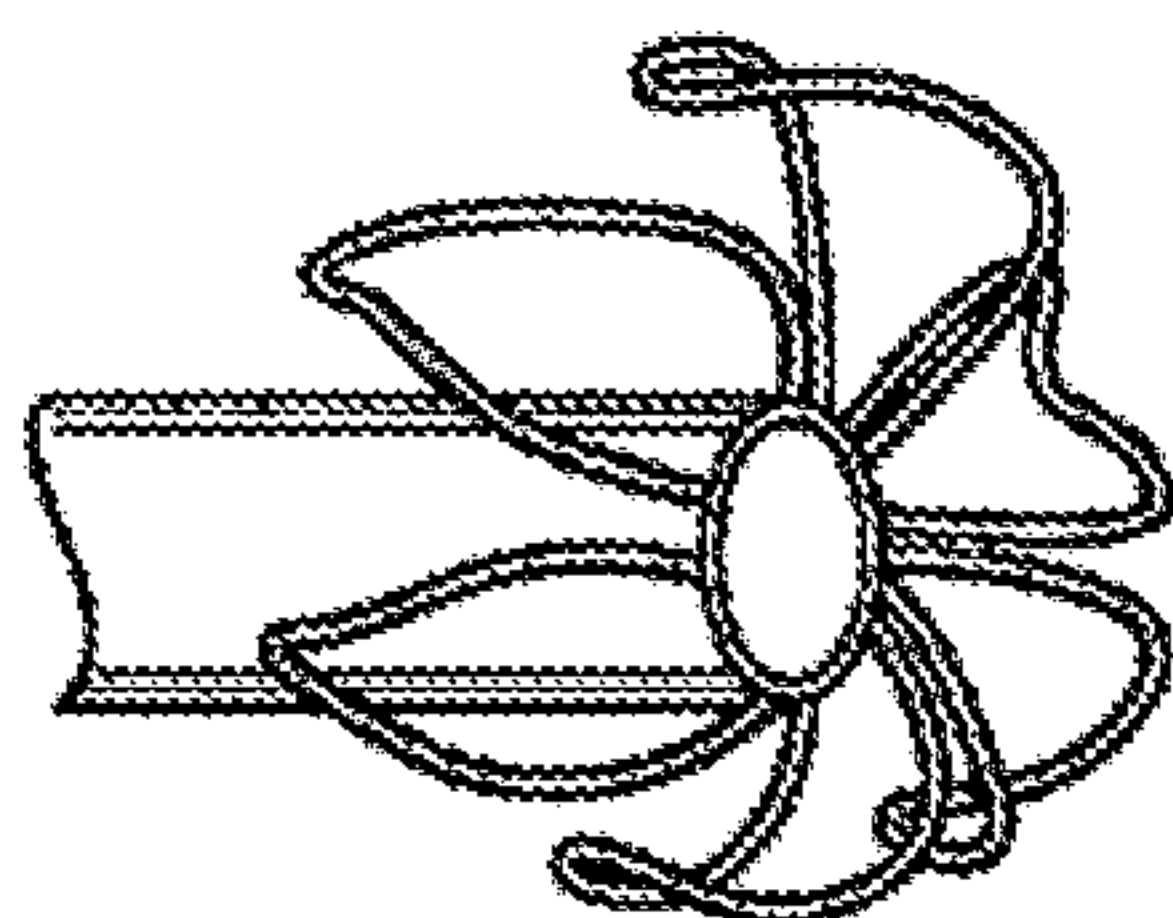

FIG. 8

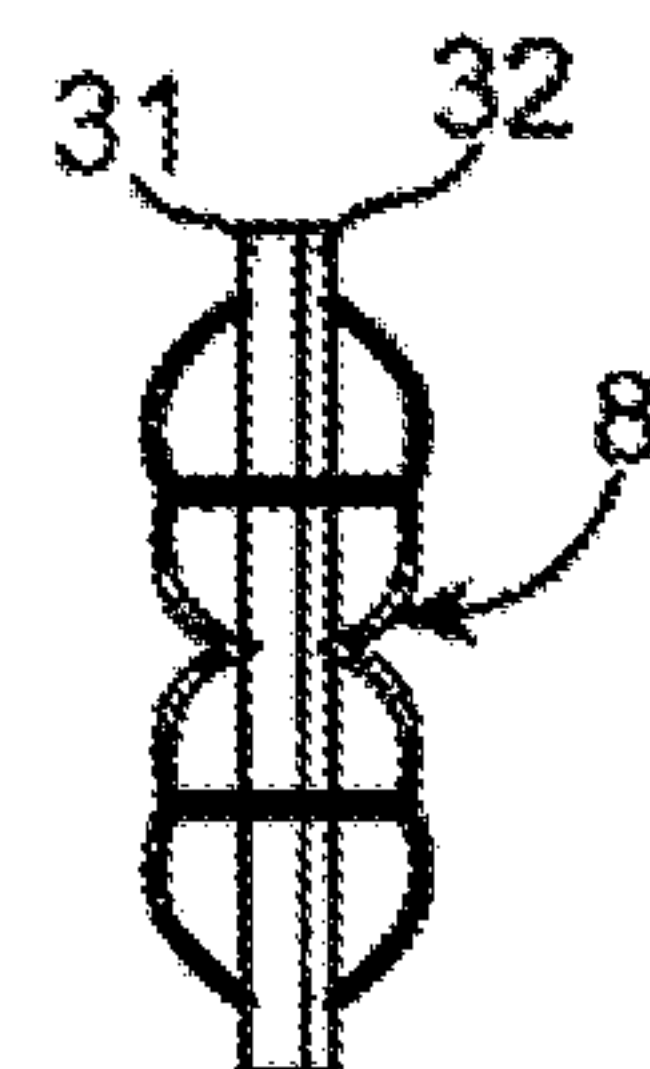

FIG. 11

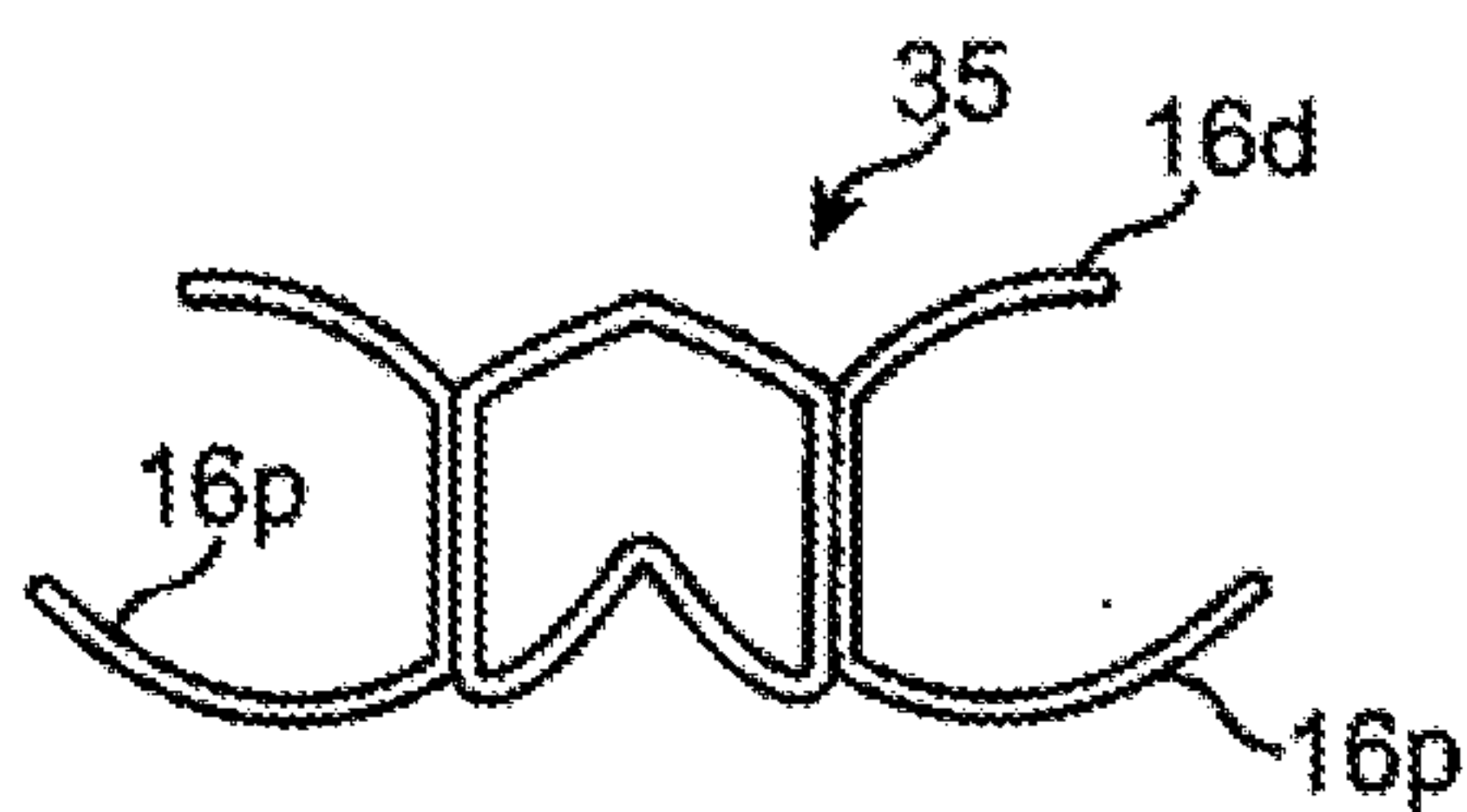

FIG. 12

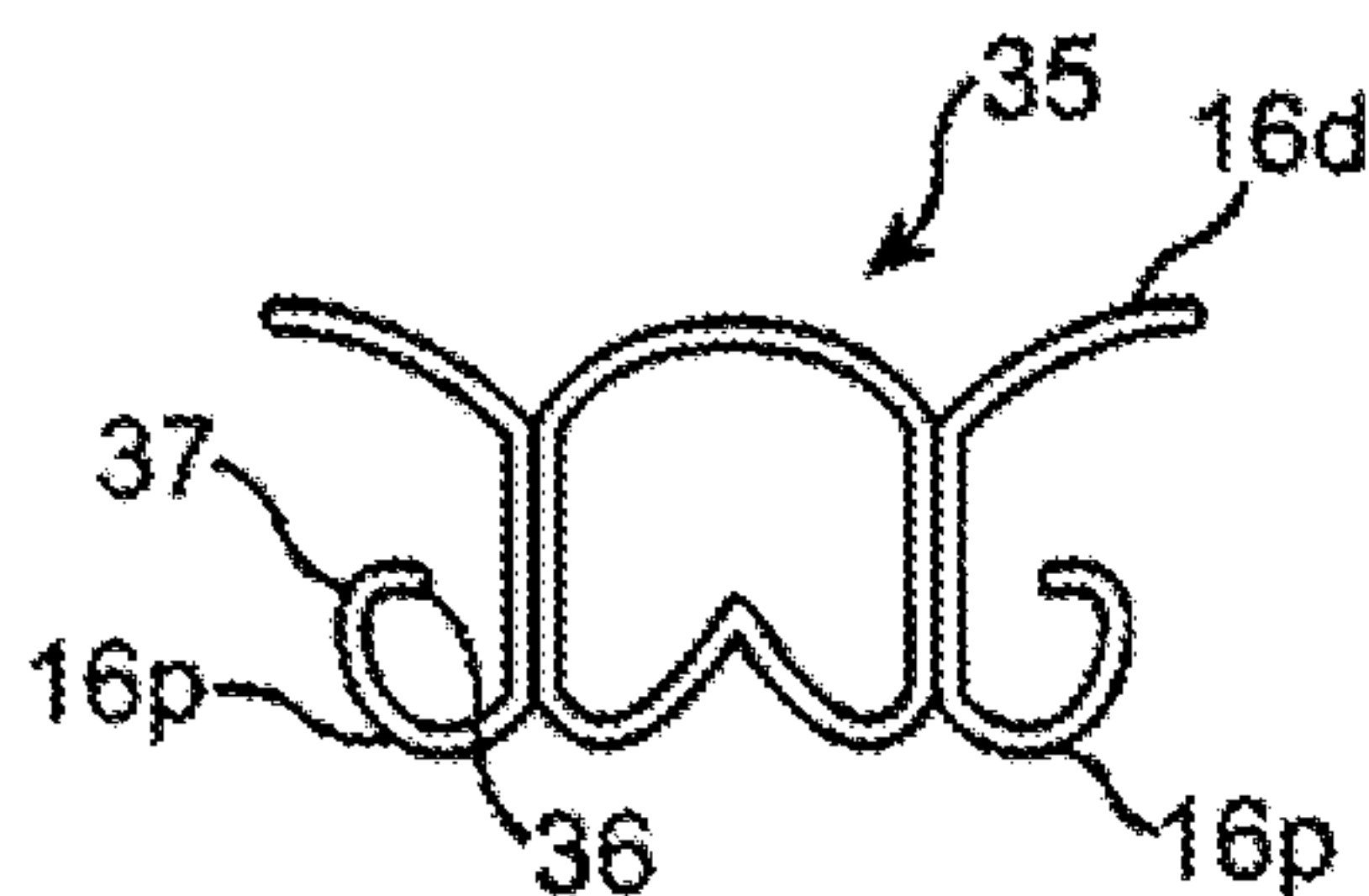

FIG. 13

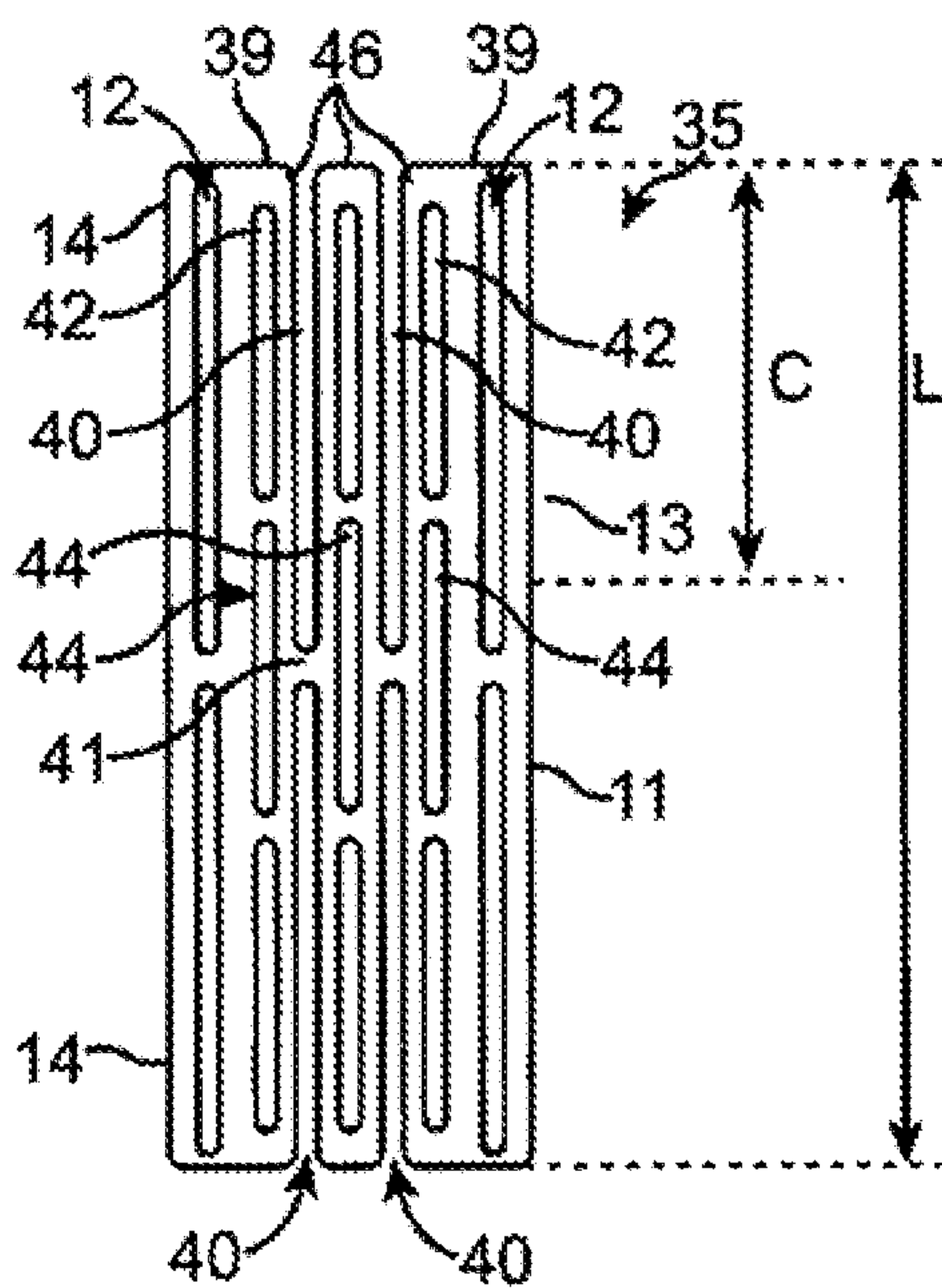

FIG. 14

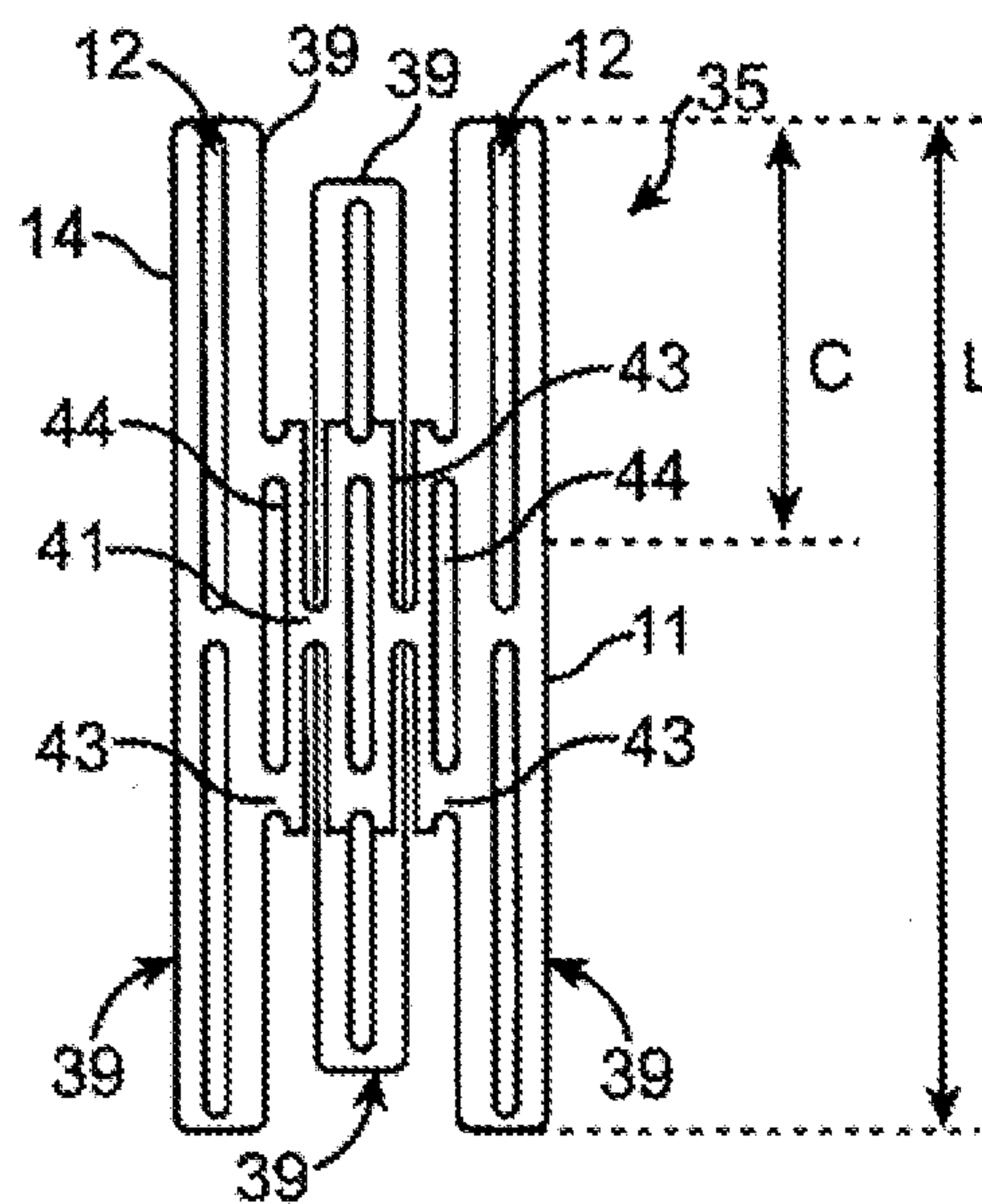

FIG. 15

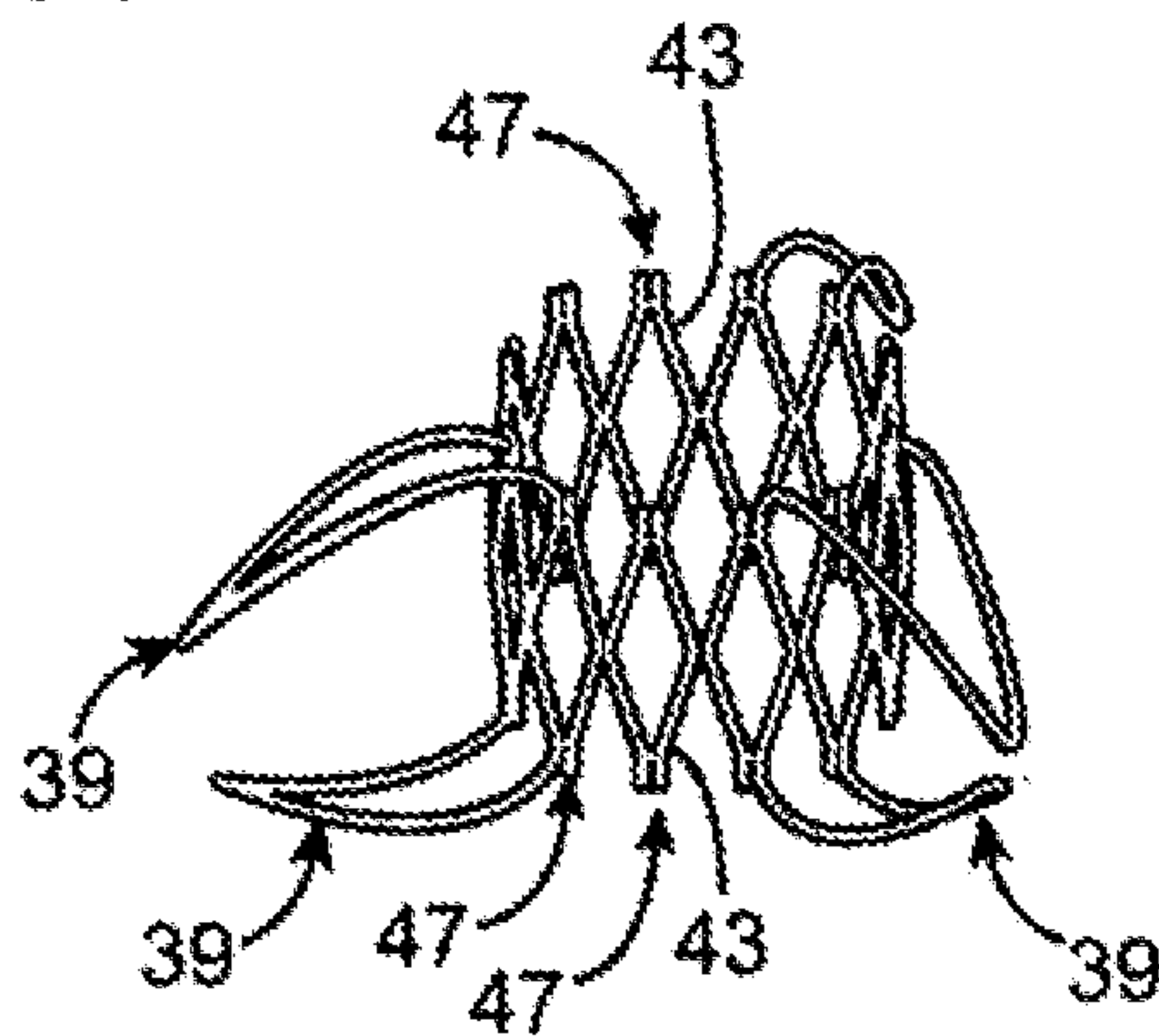

FIG. 16

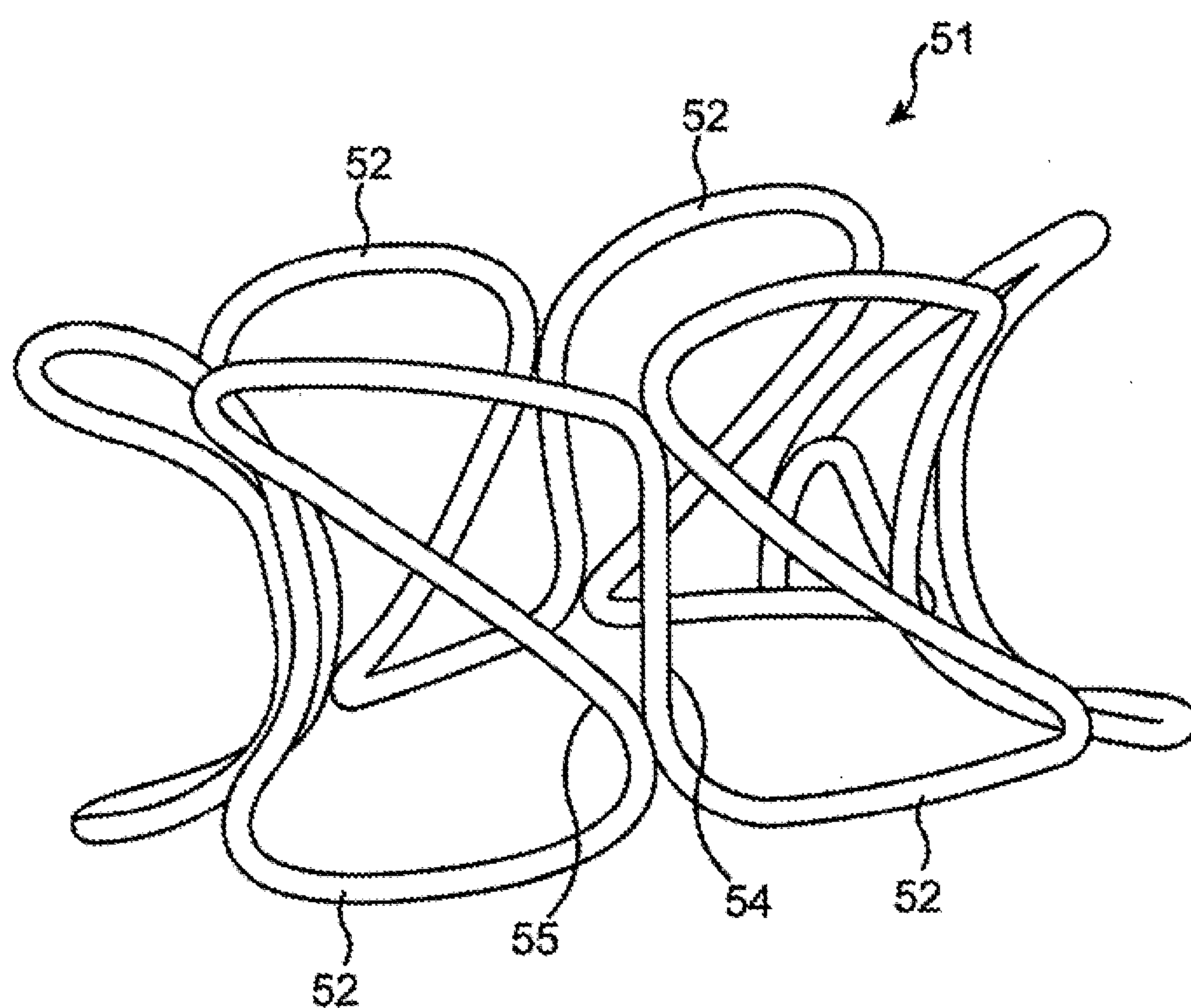

FIG. 17

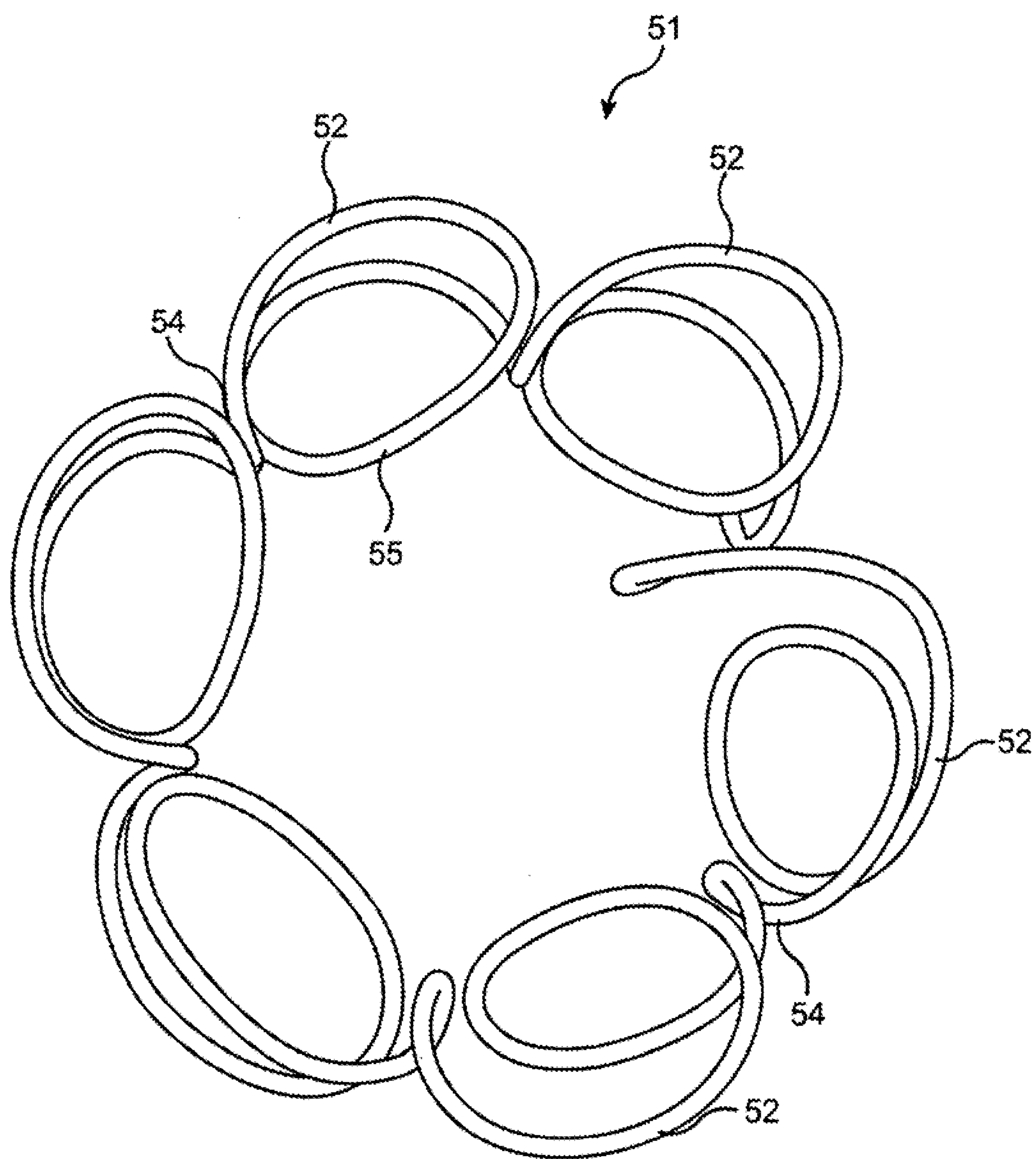

FIG. 18

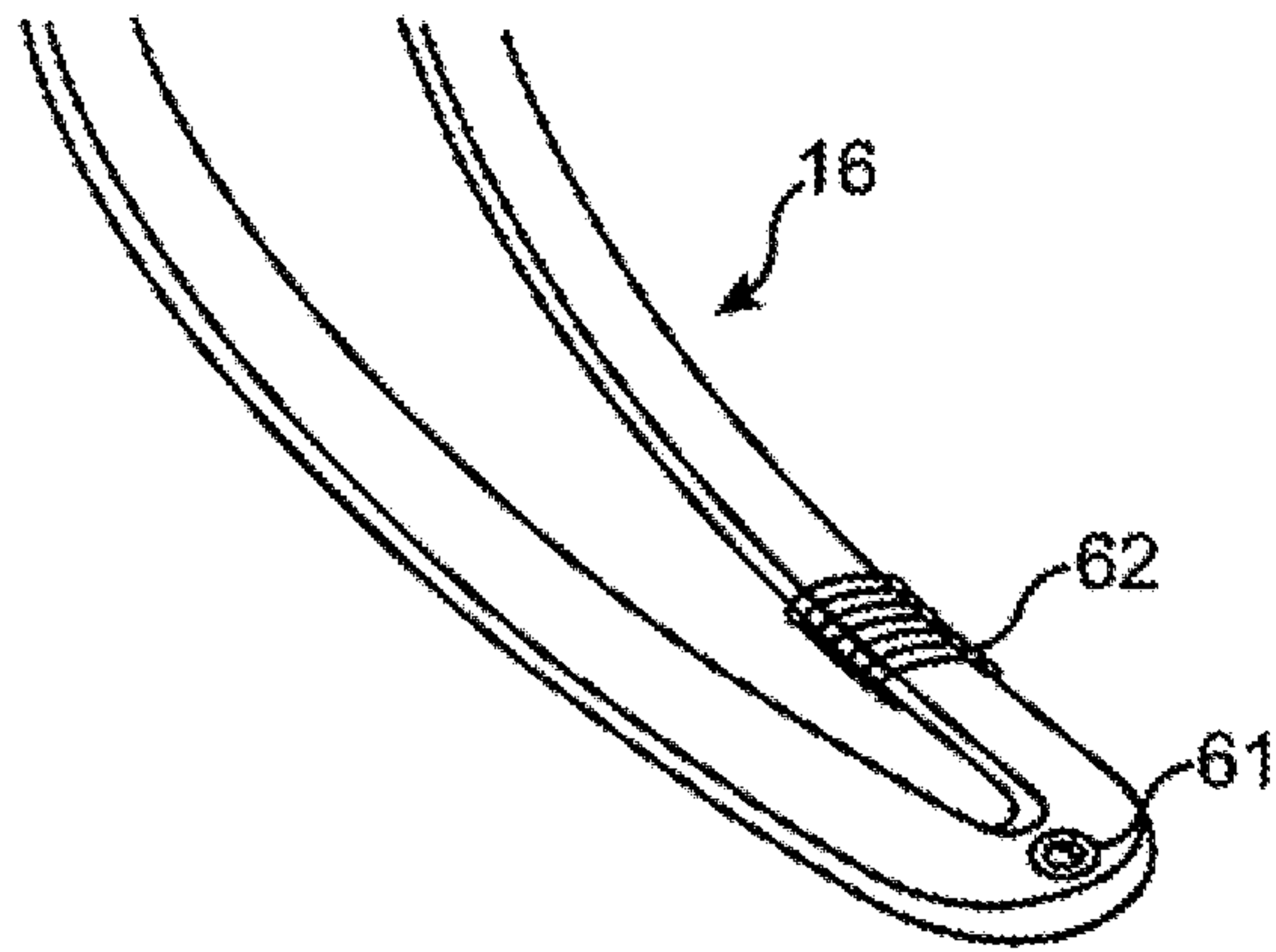

FIG. 19

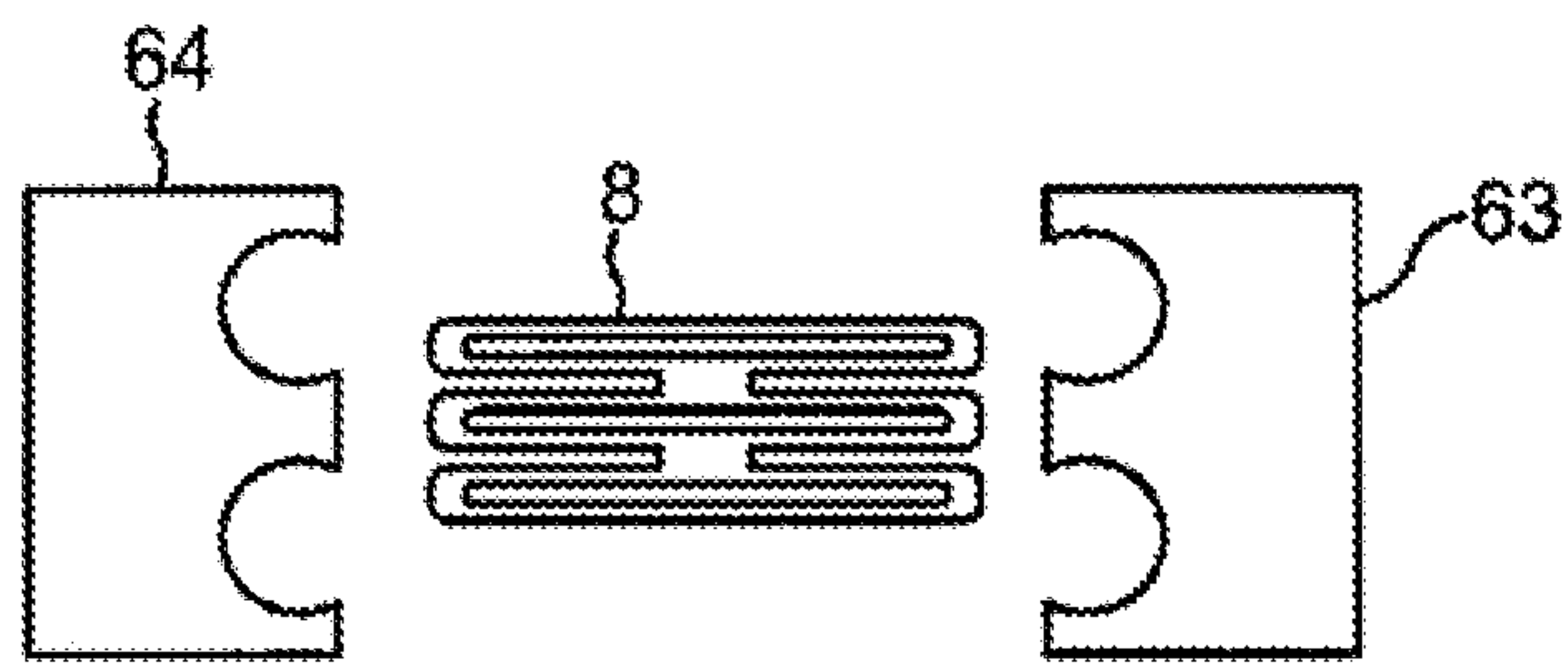

FIG. 21

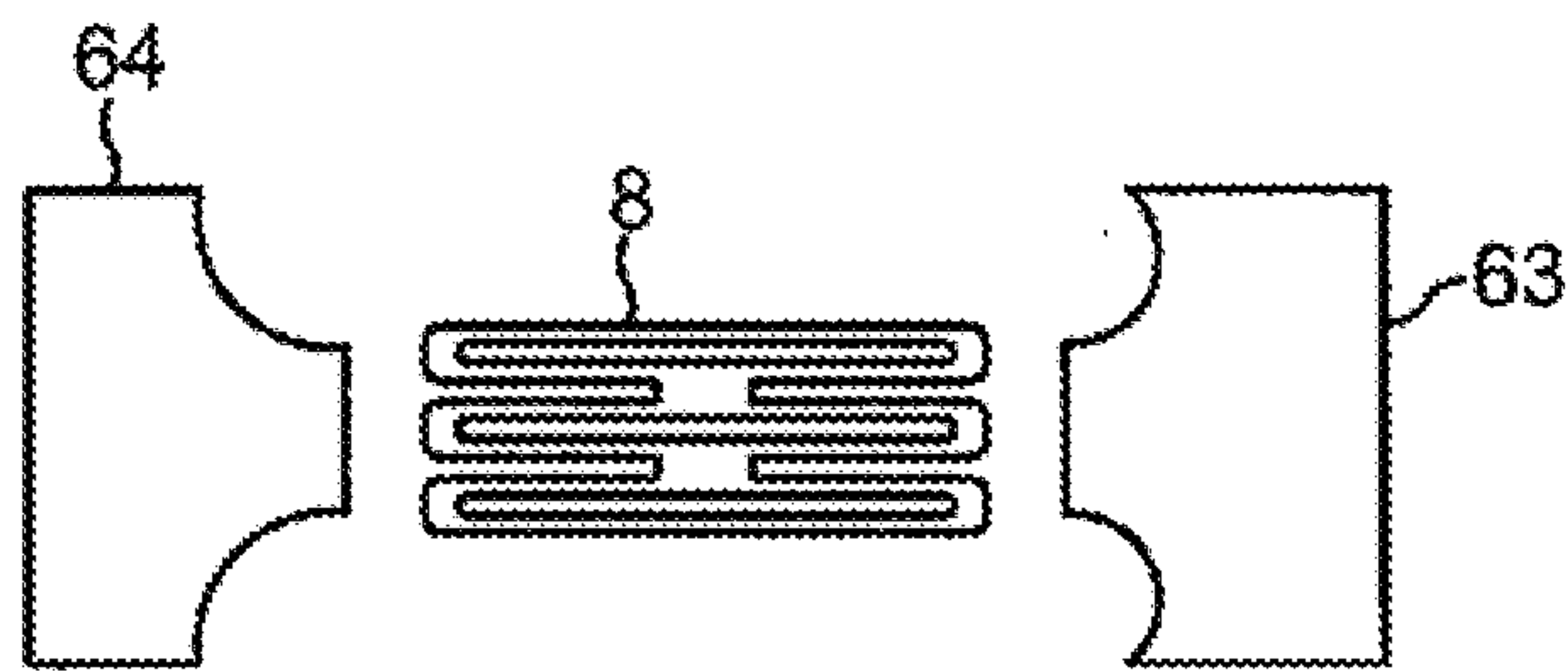

FIG. 20

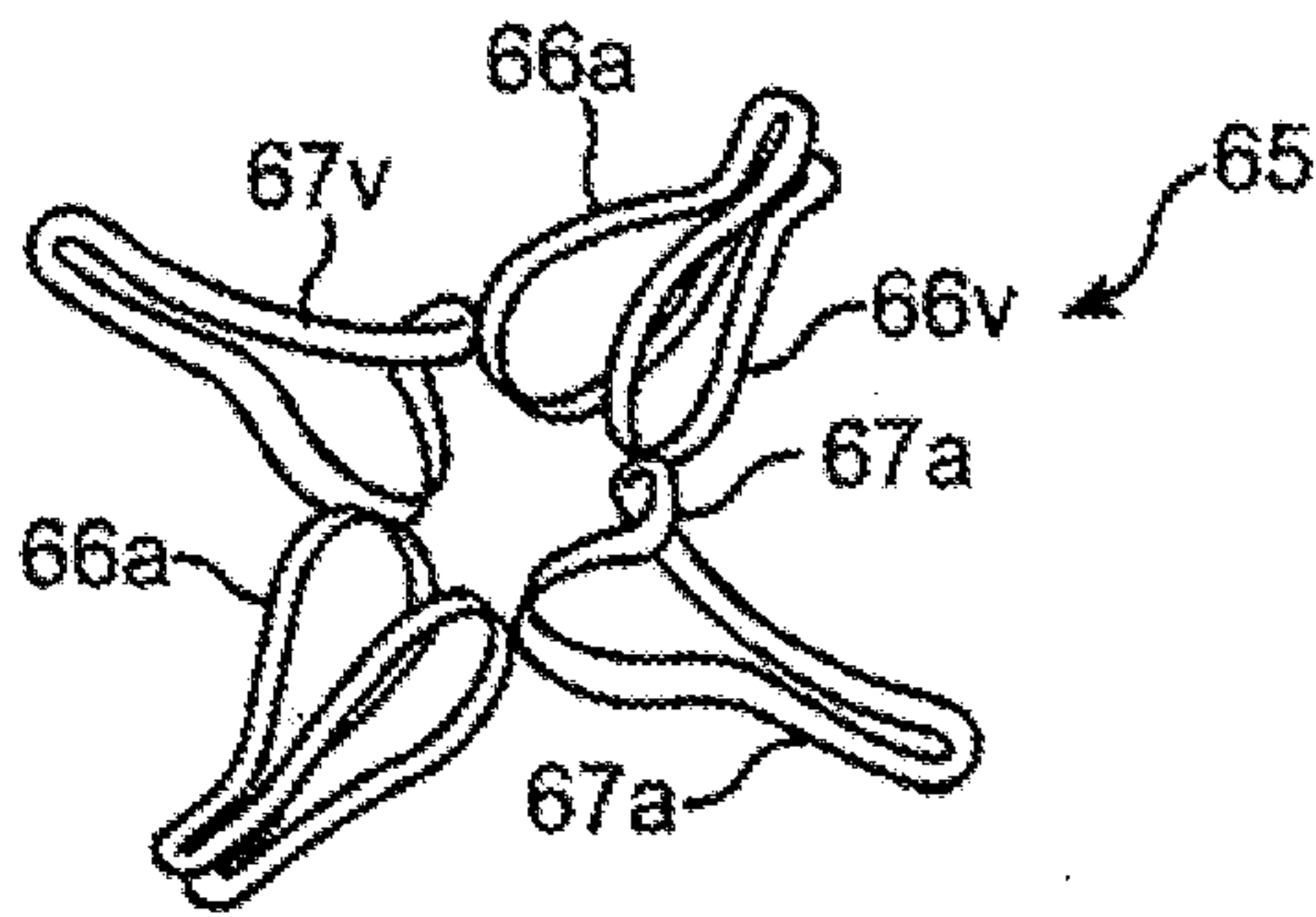

FIG. 22

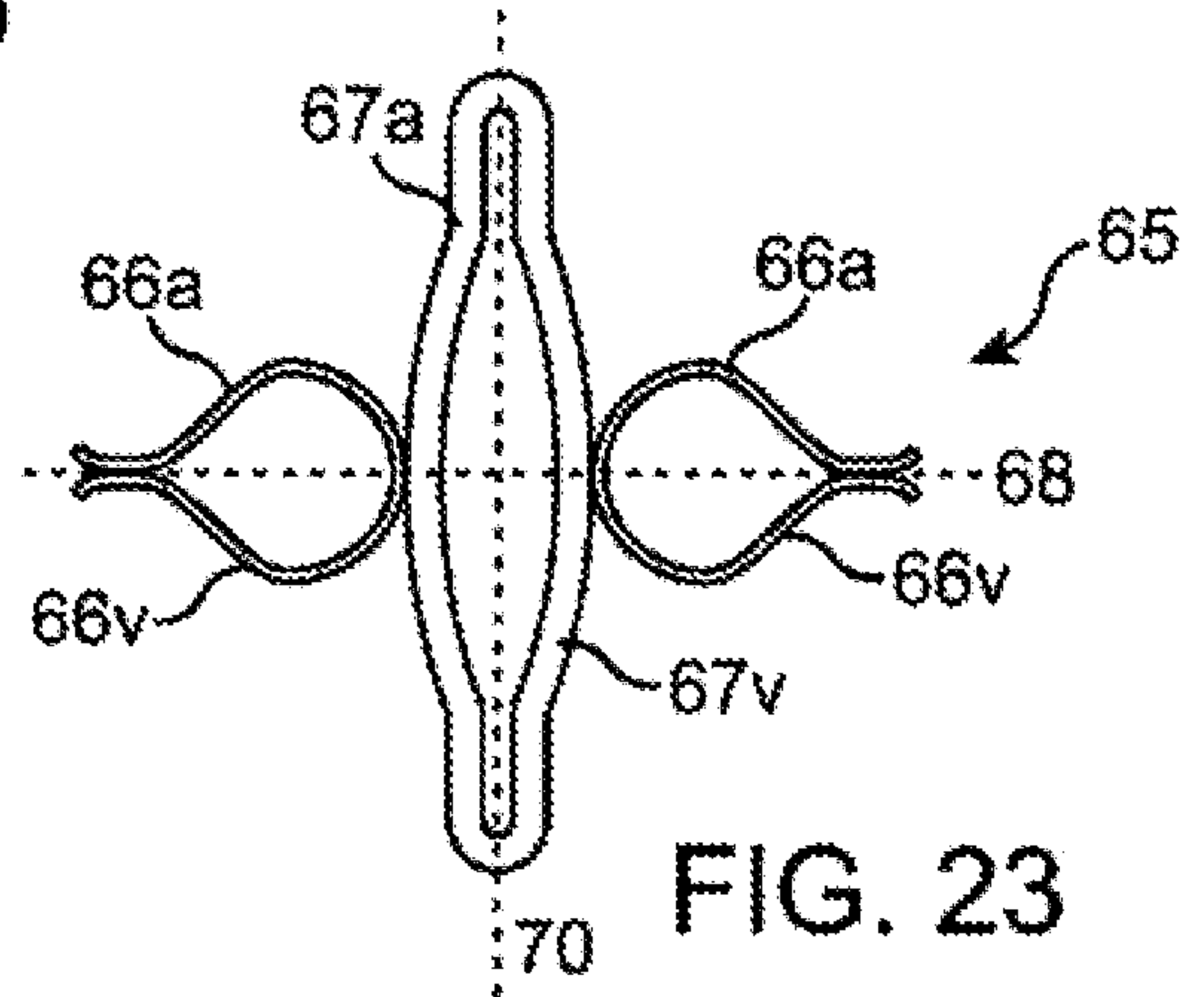

FIG. 23

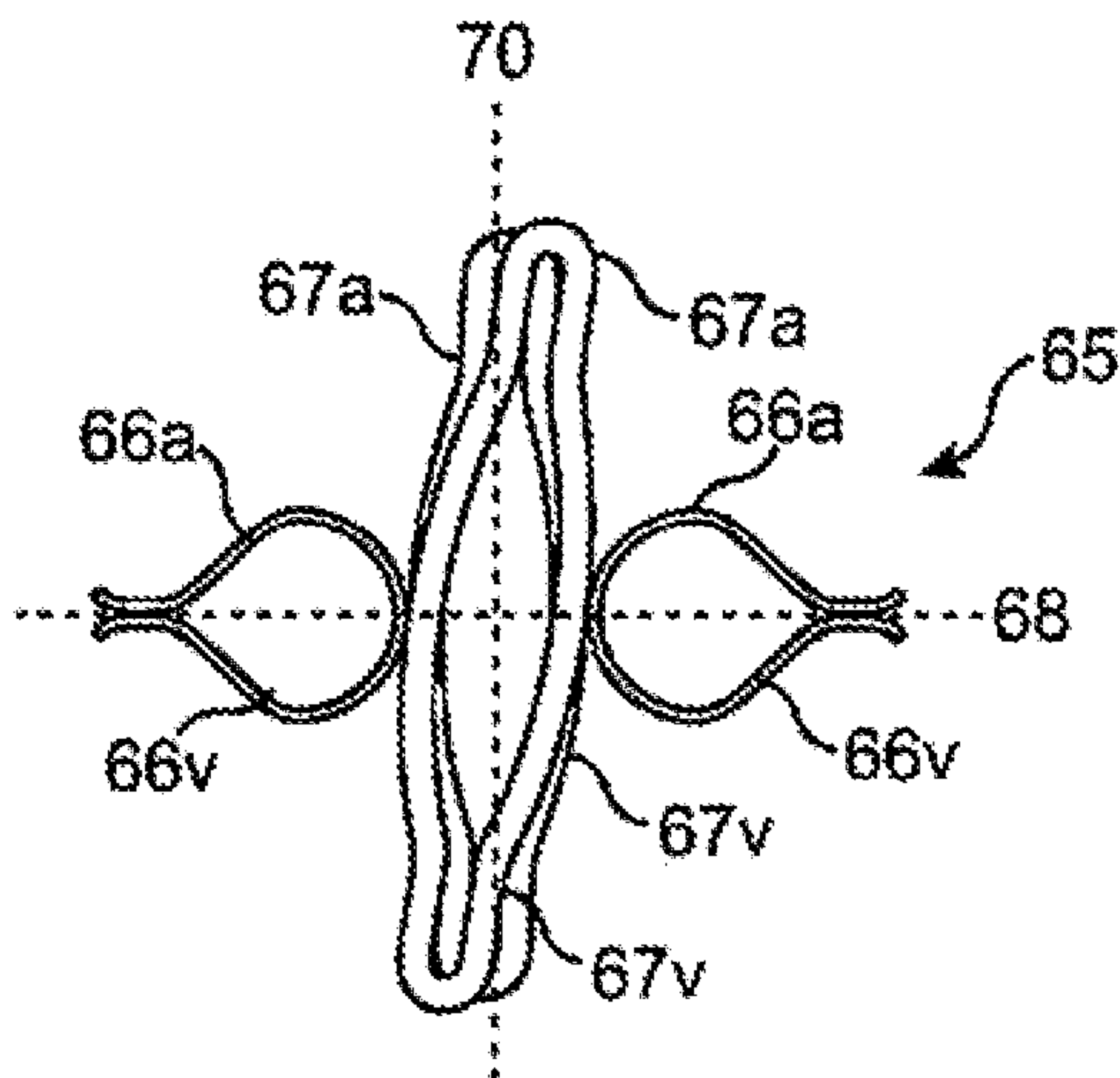

FIG. 24

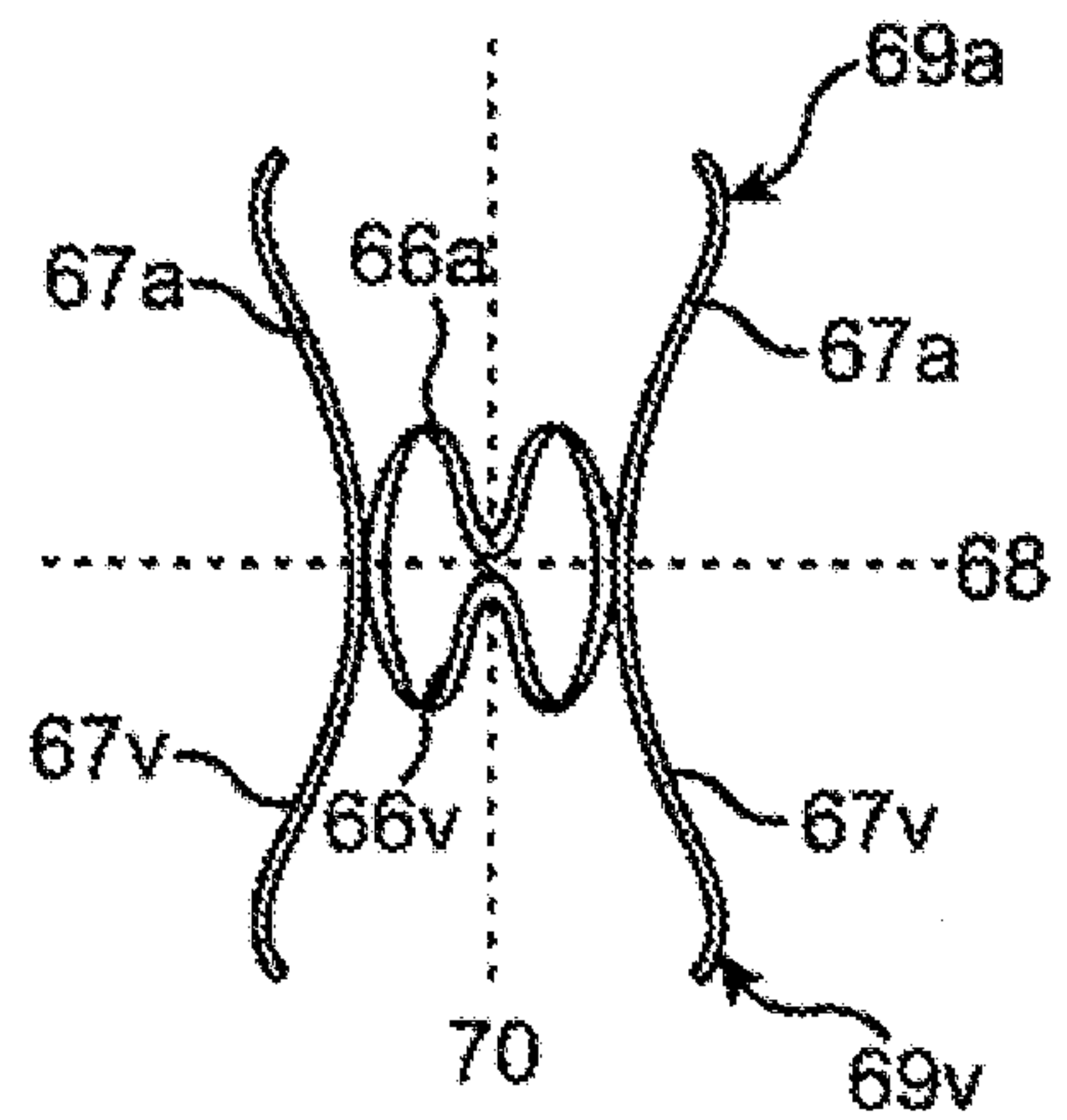

FIG. 25

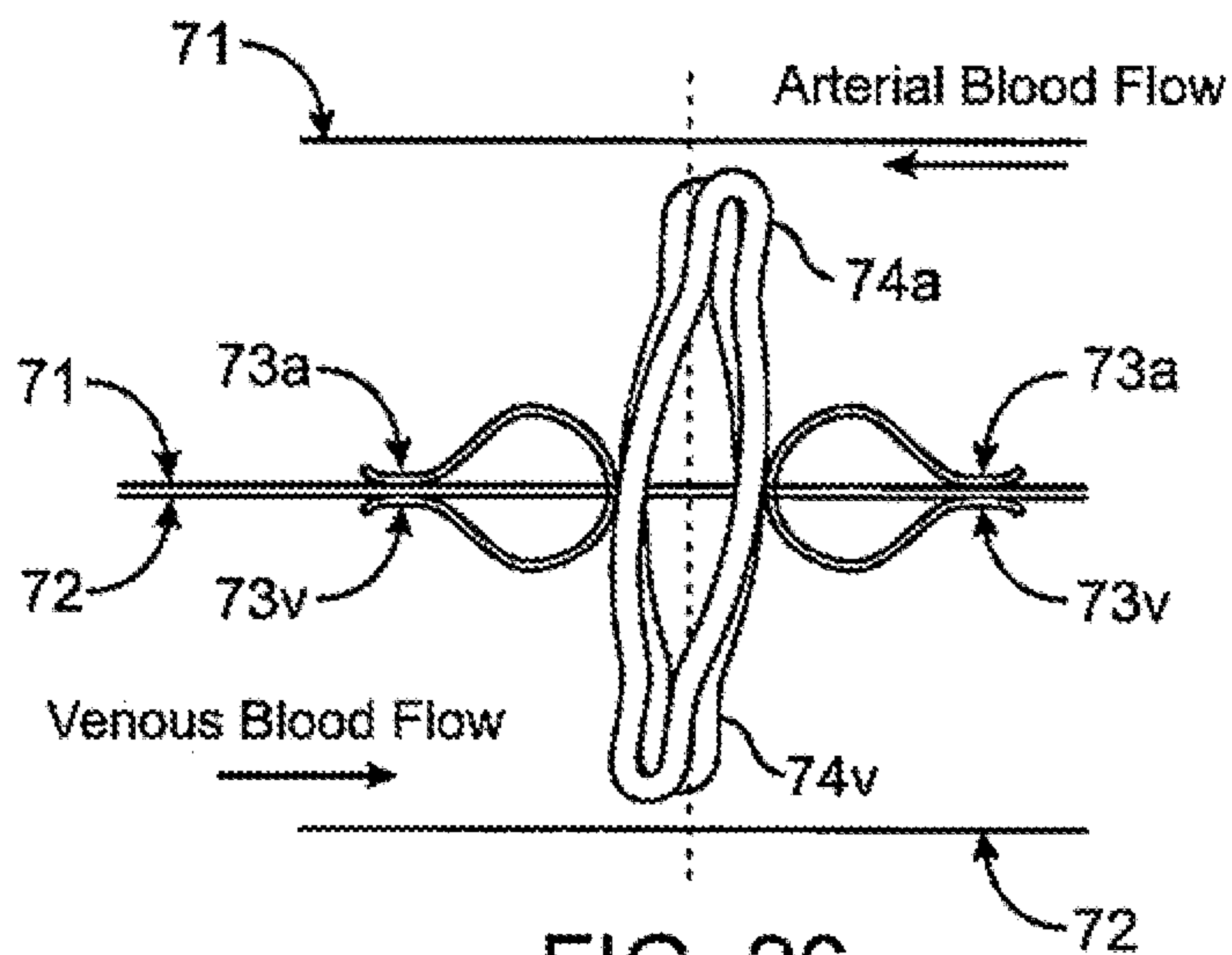

FIG. 26

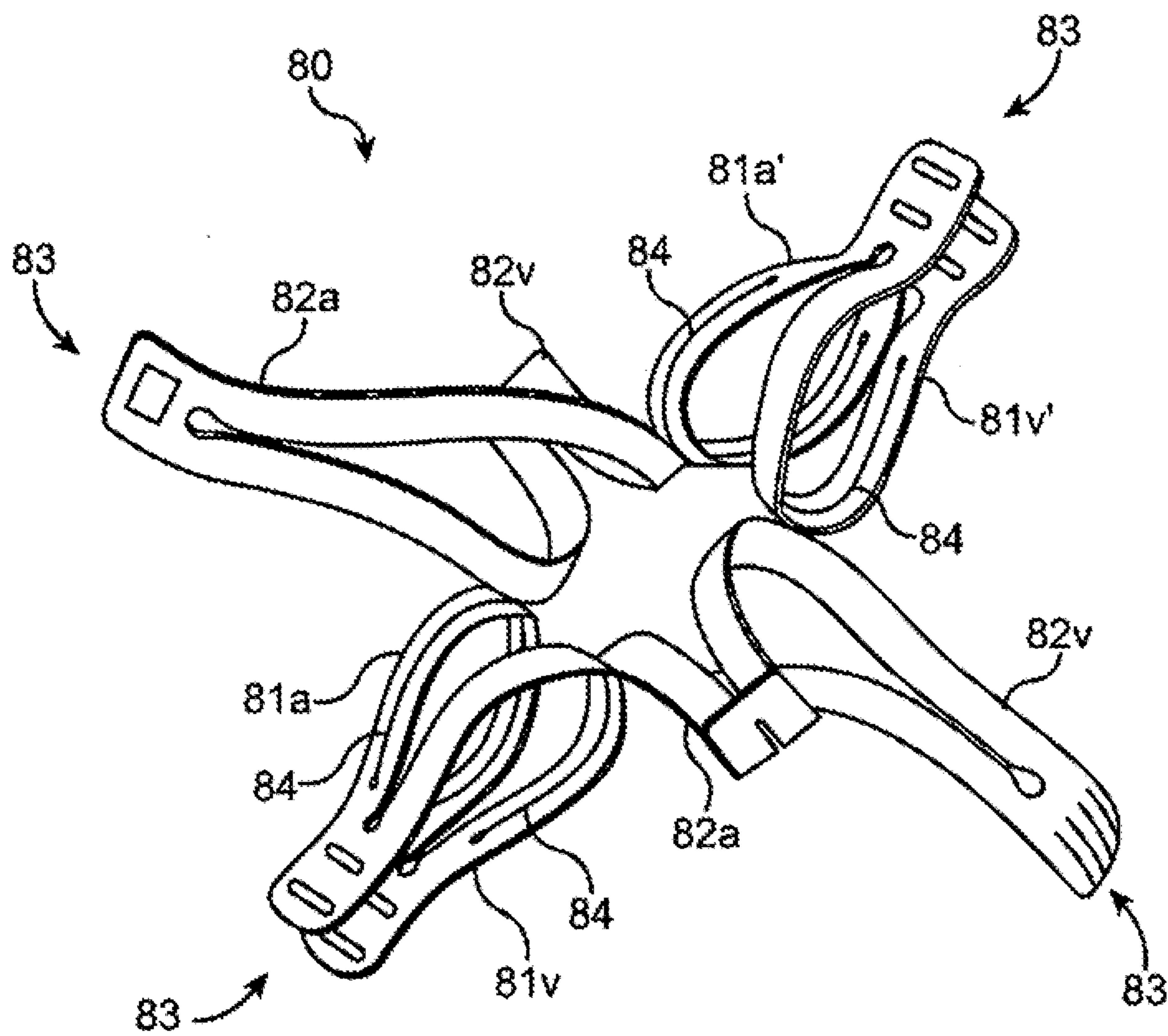

FIG. 27

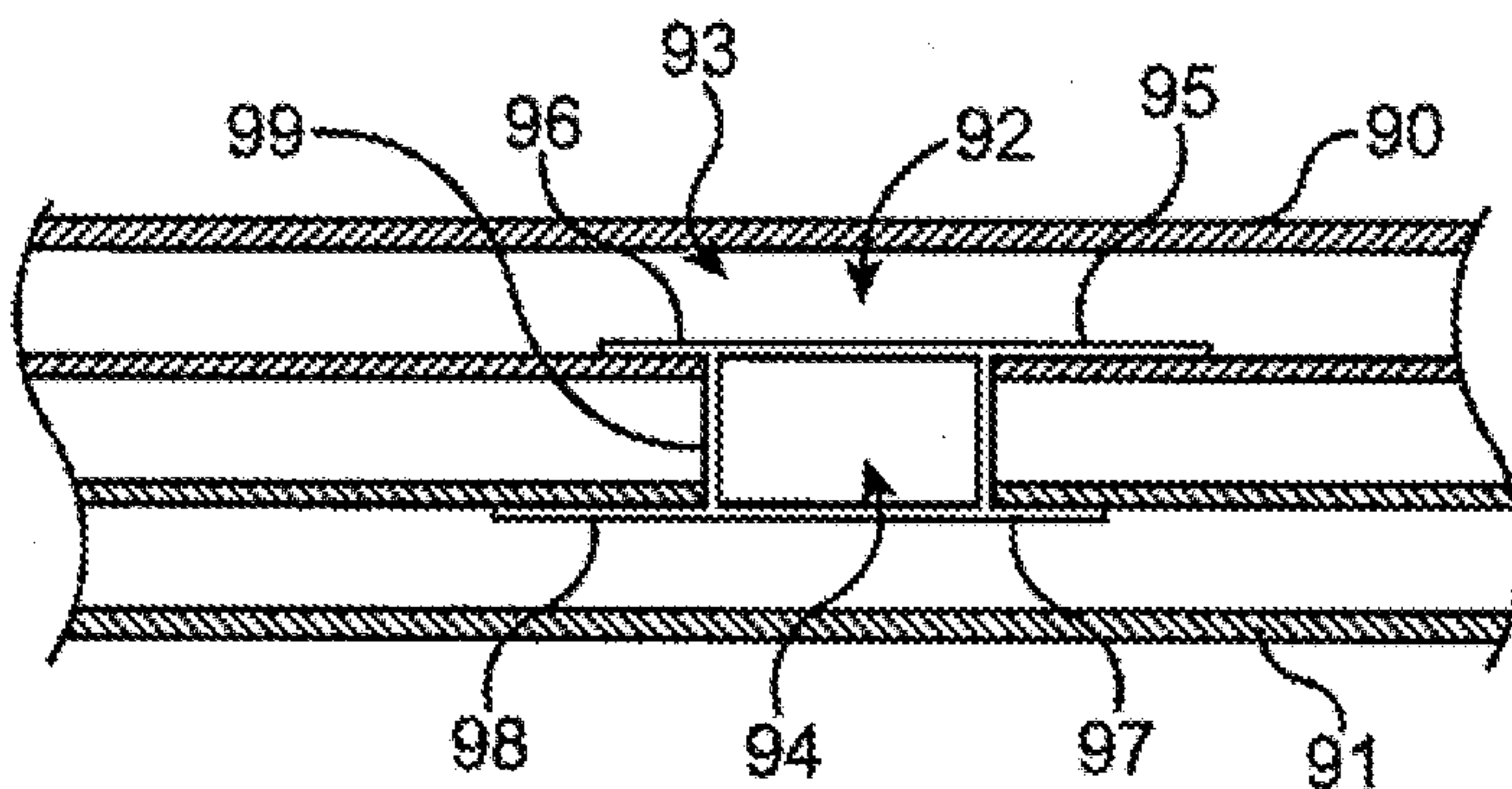

FIG. 28

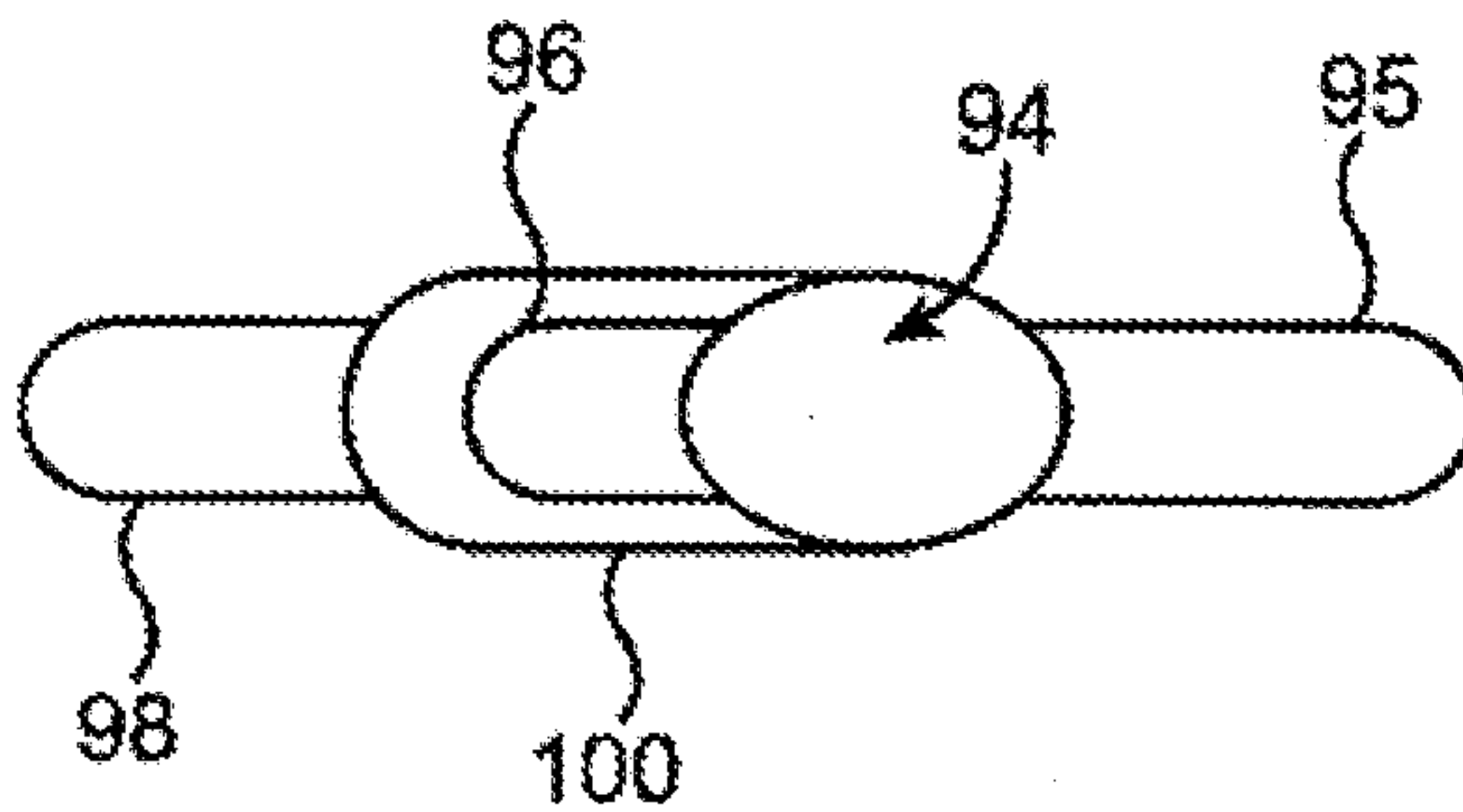

FIG. 29

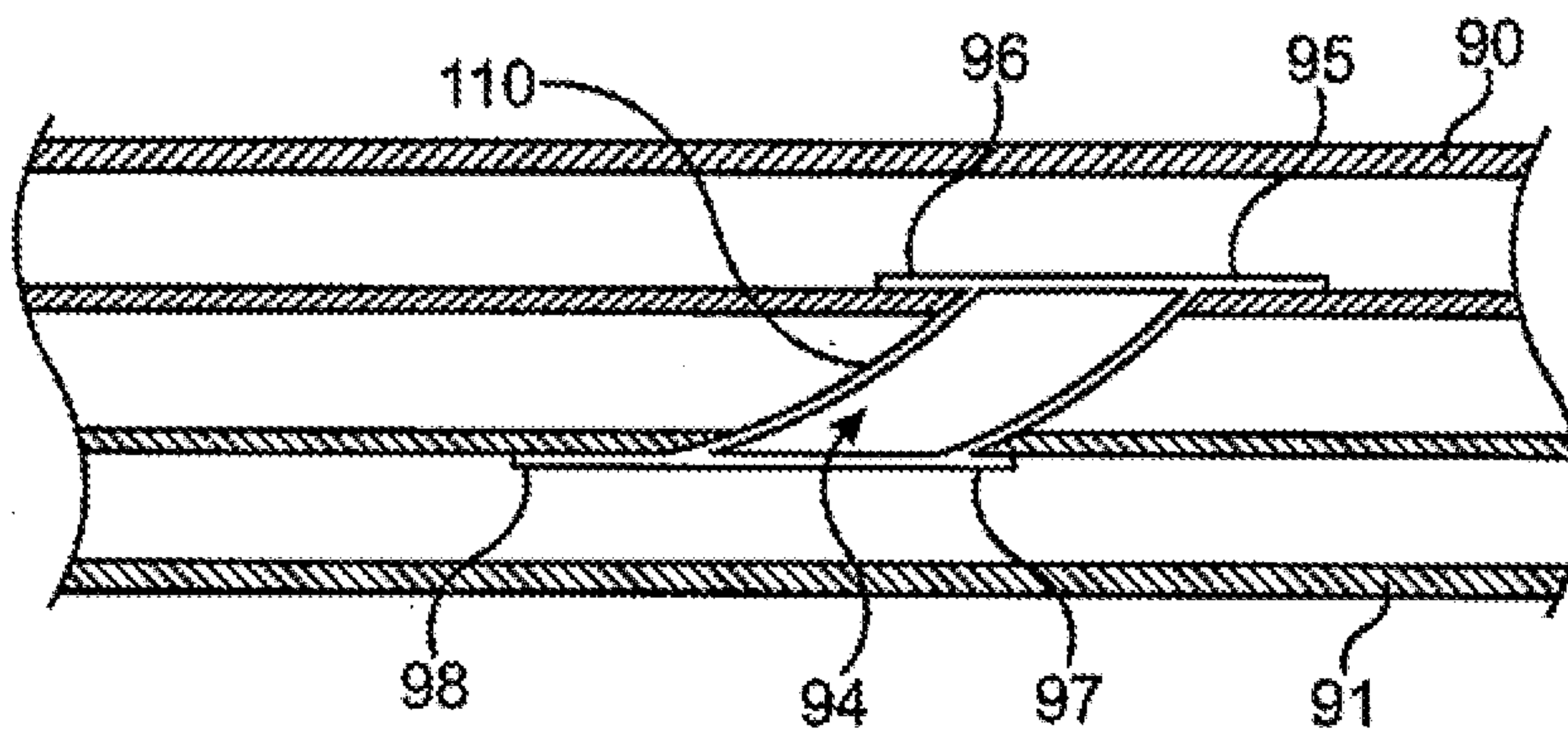

FIG. 30

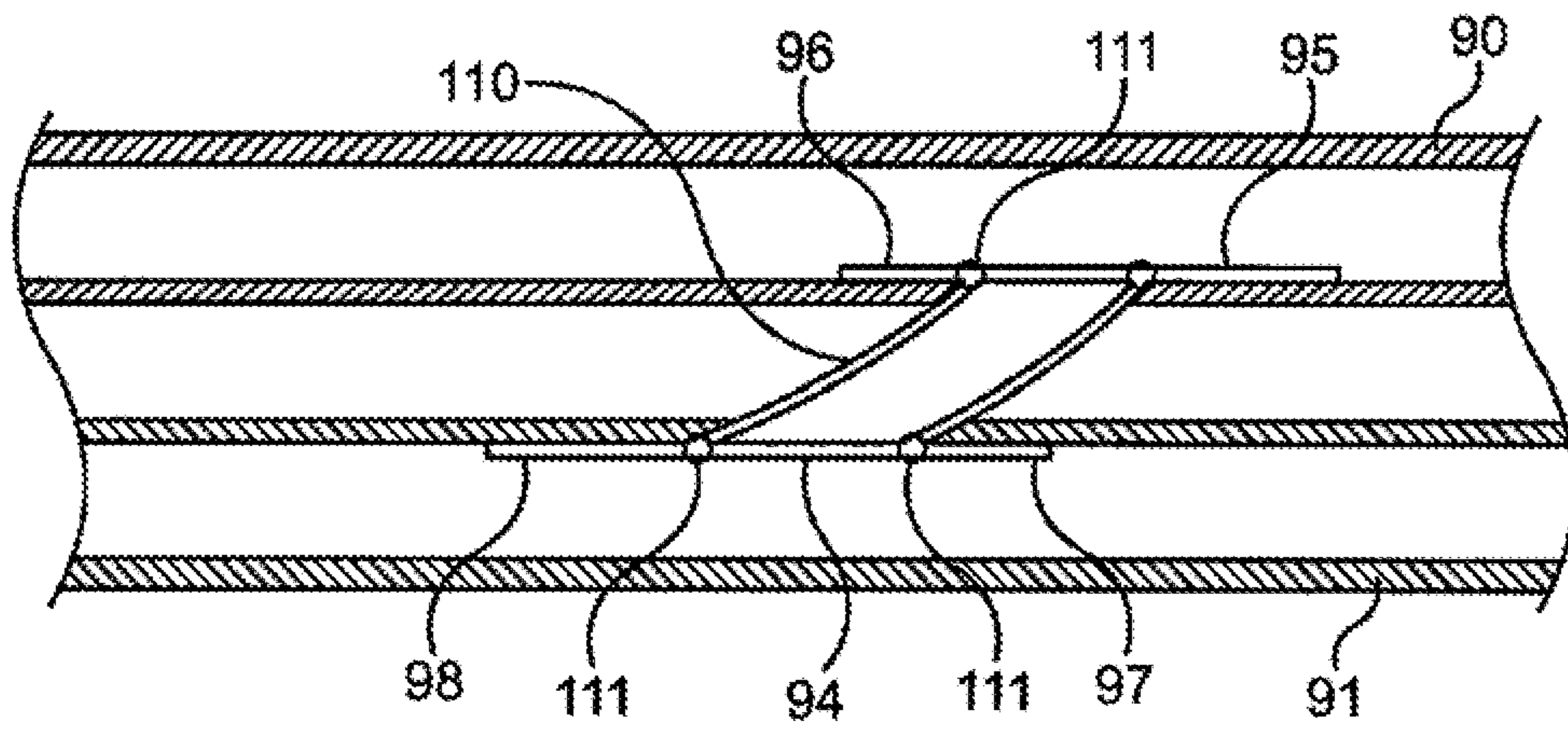

FIG. 31

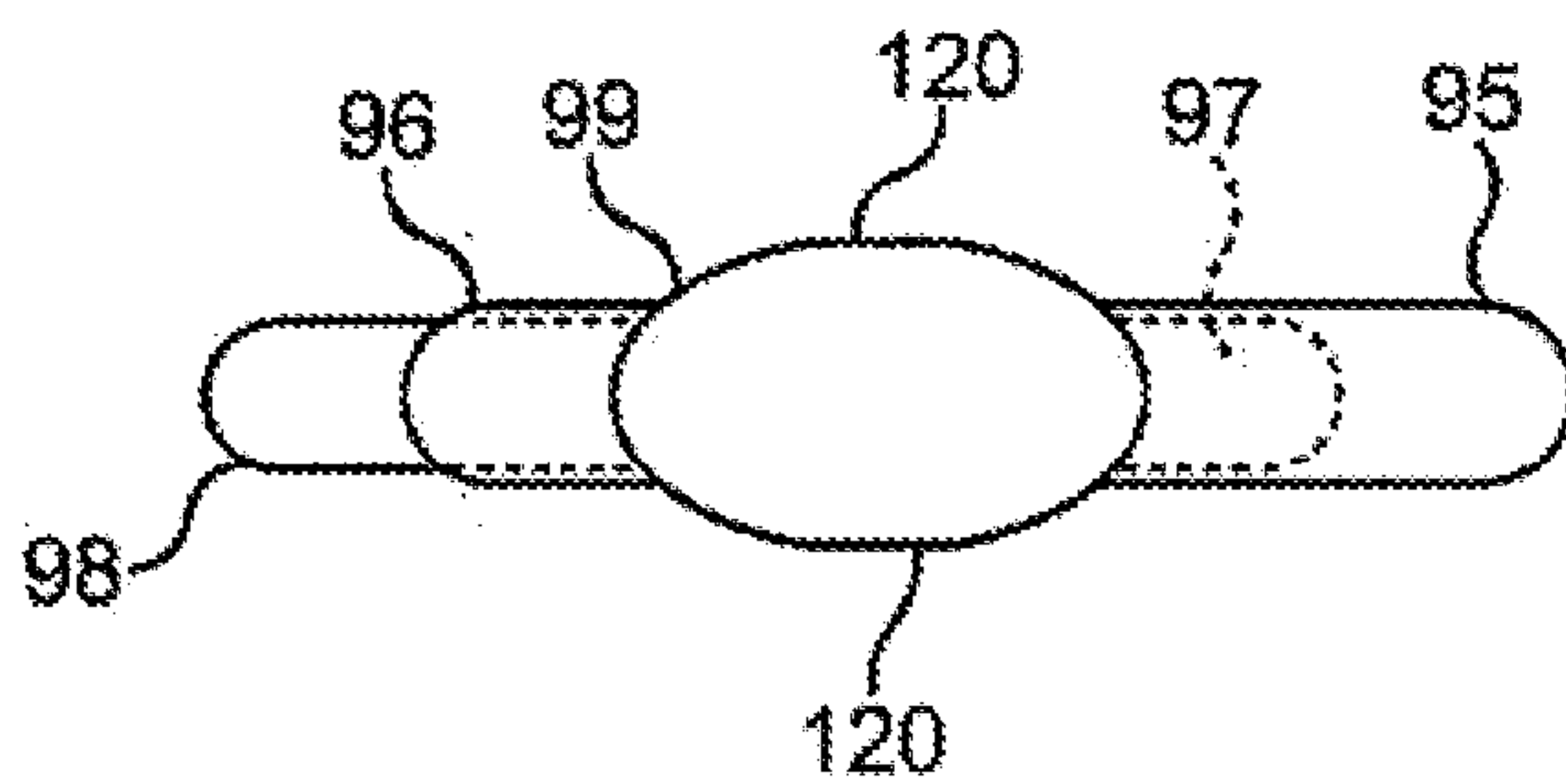

FIG. 32

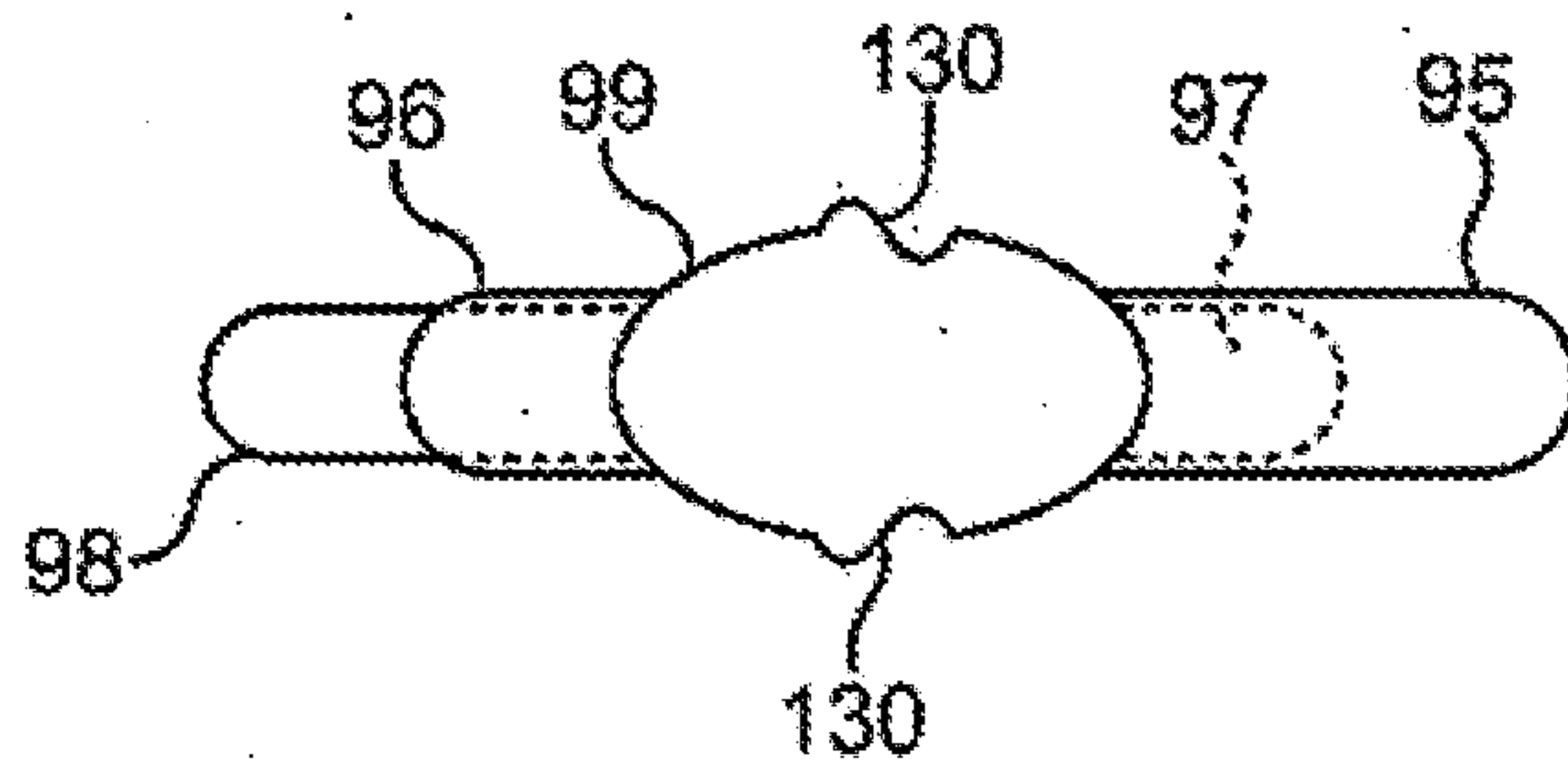

FIG. 33

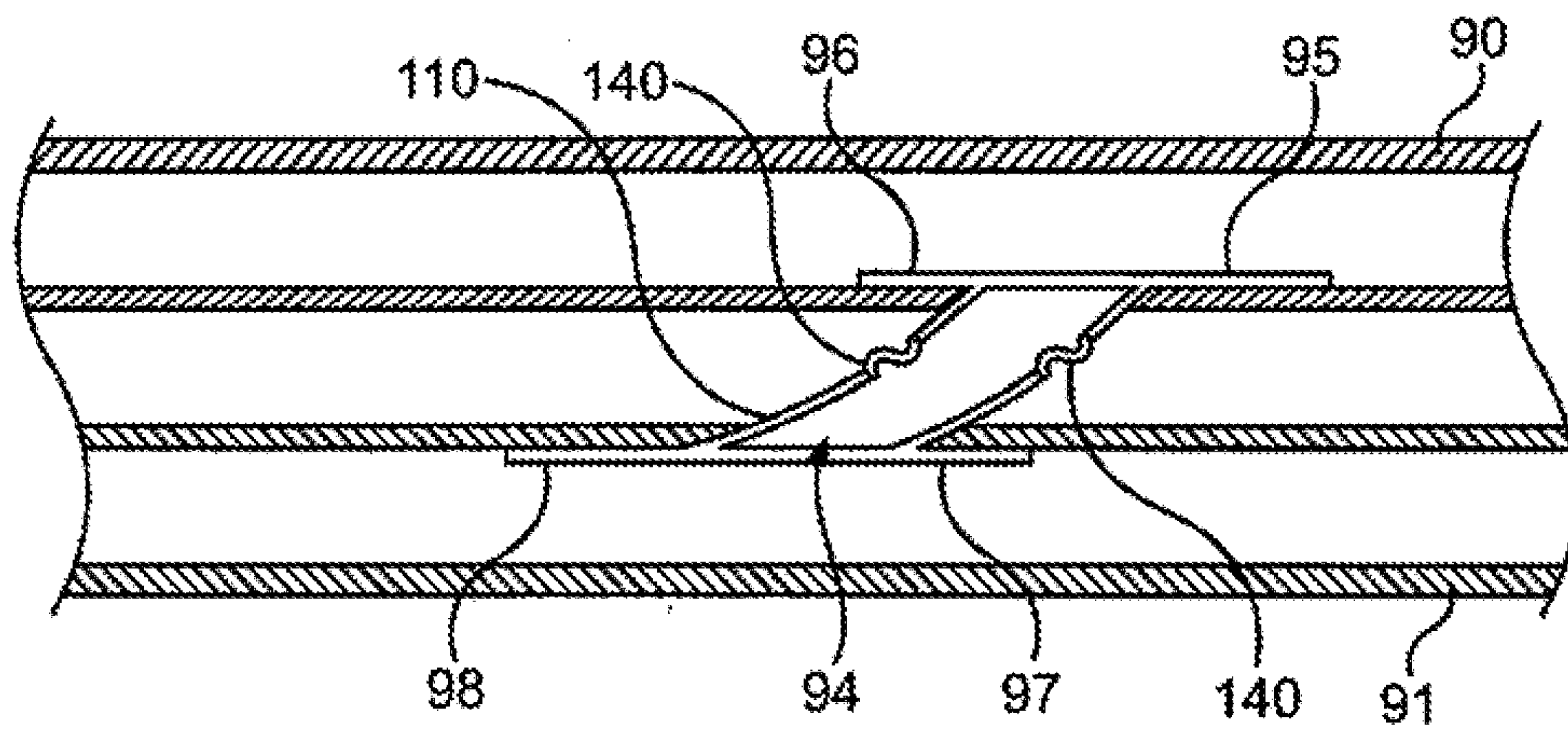

FIG. 34

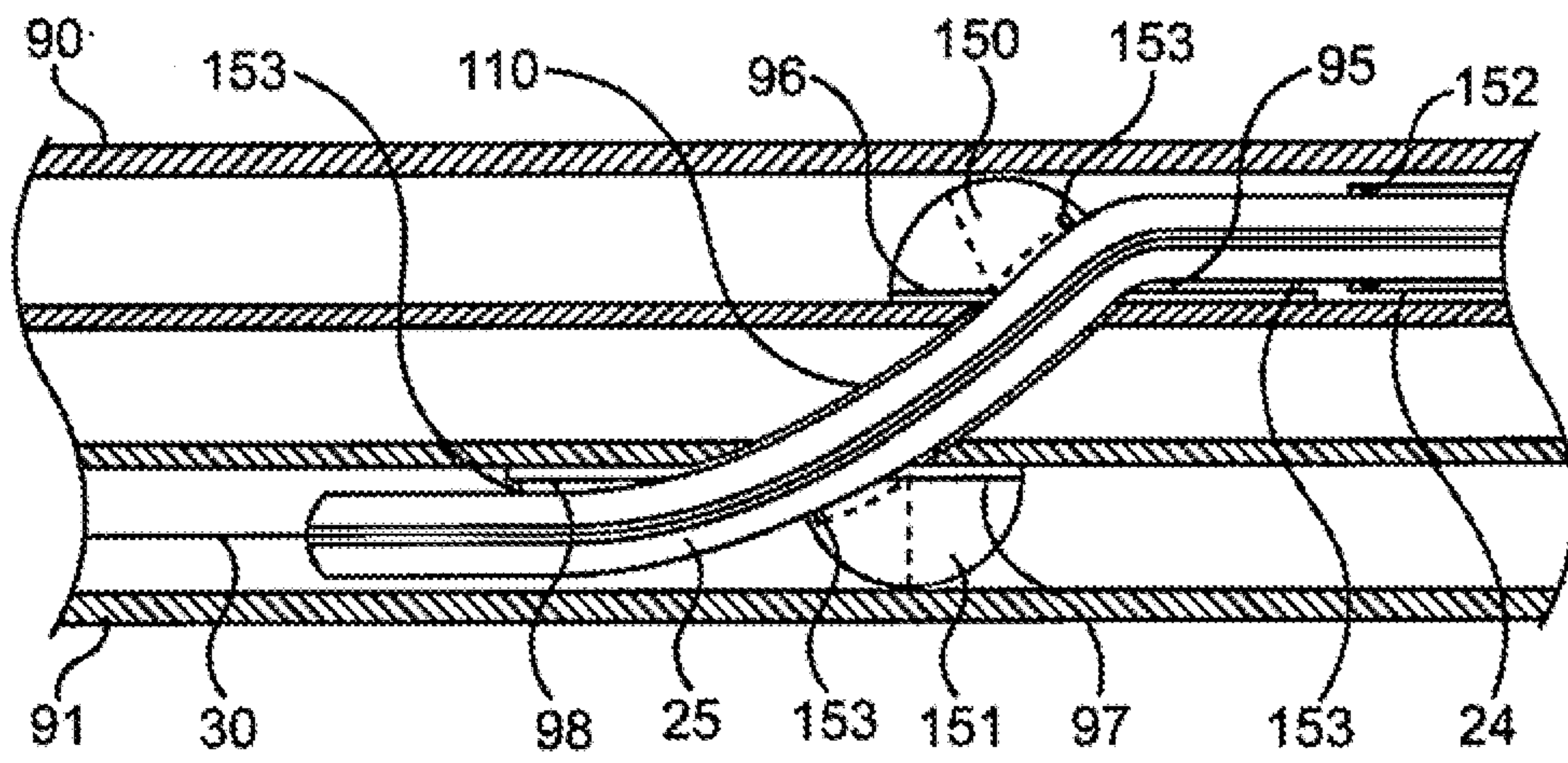

FIG. 35A

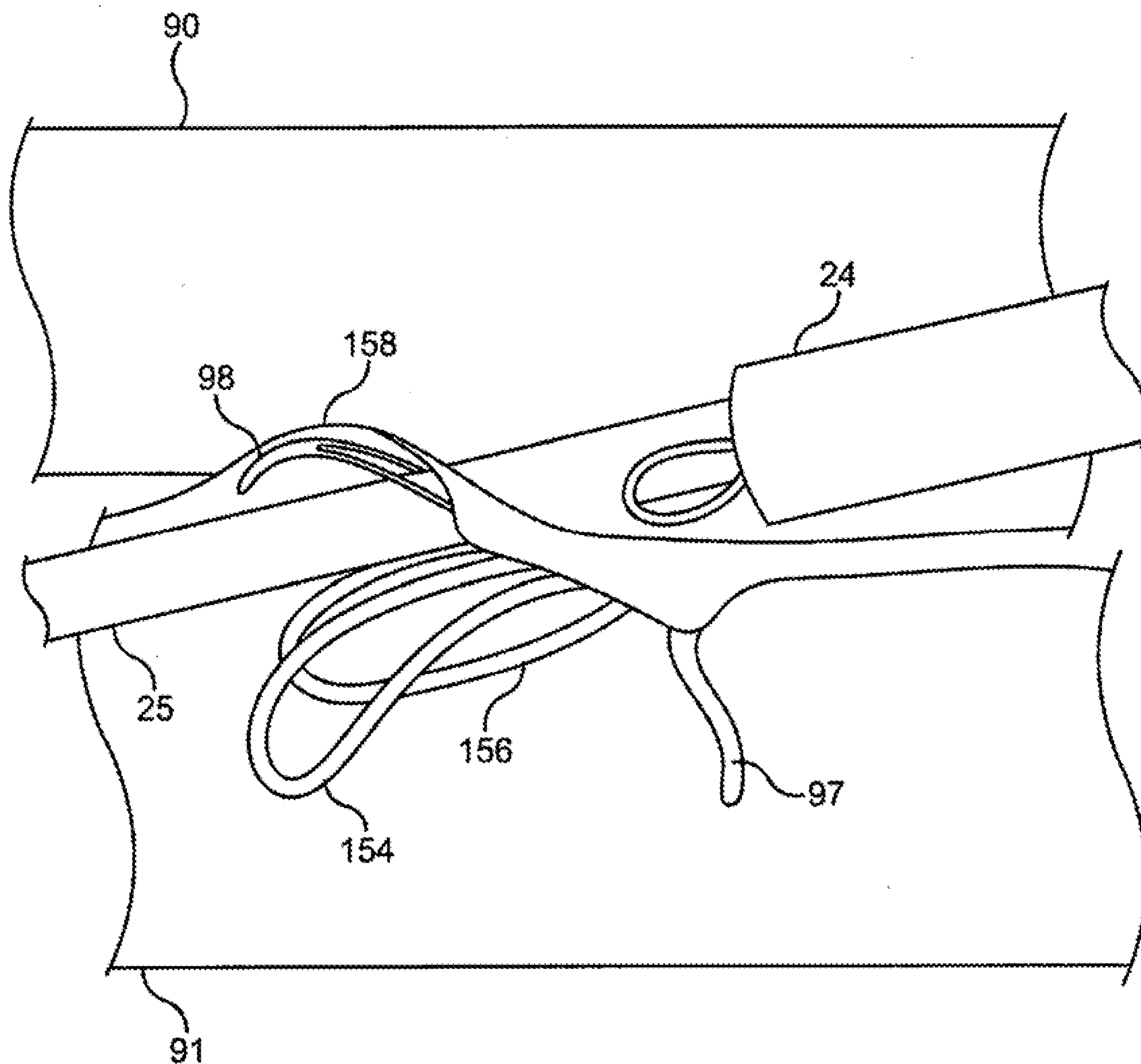

FIG. 35B

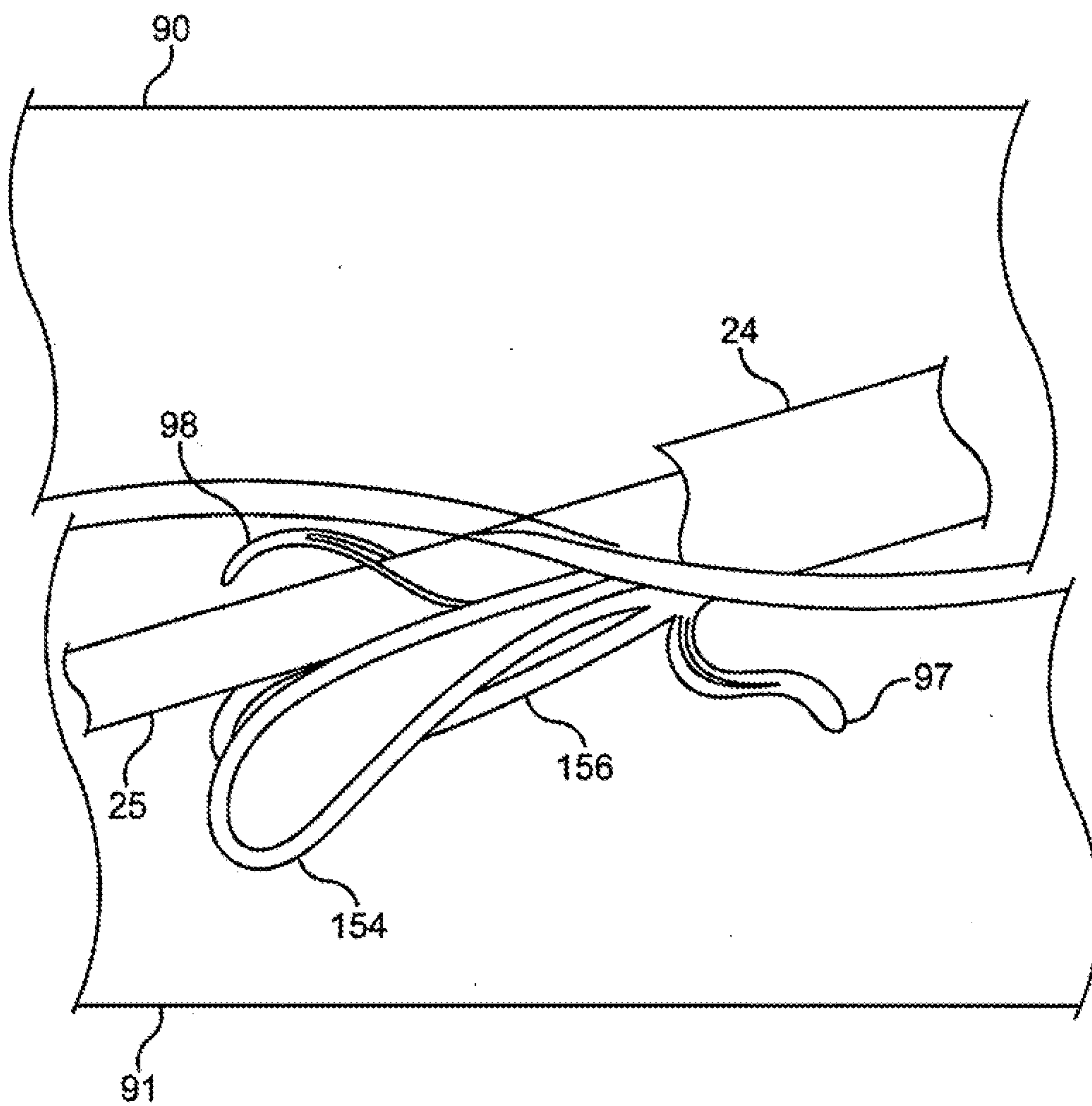

FIG. 35C

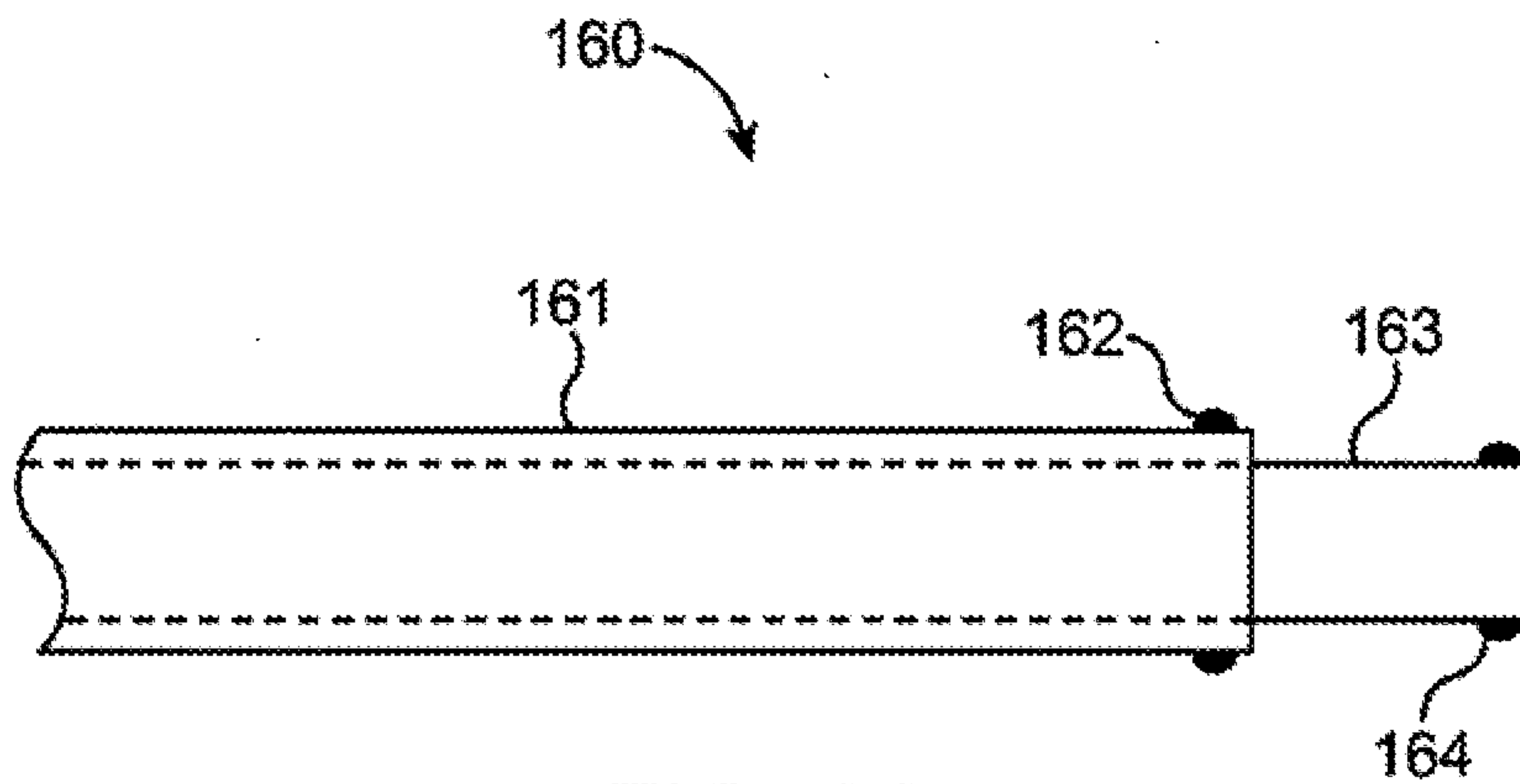

FIG. 36

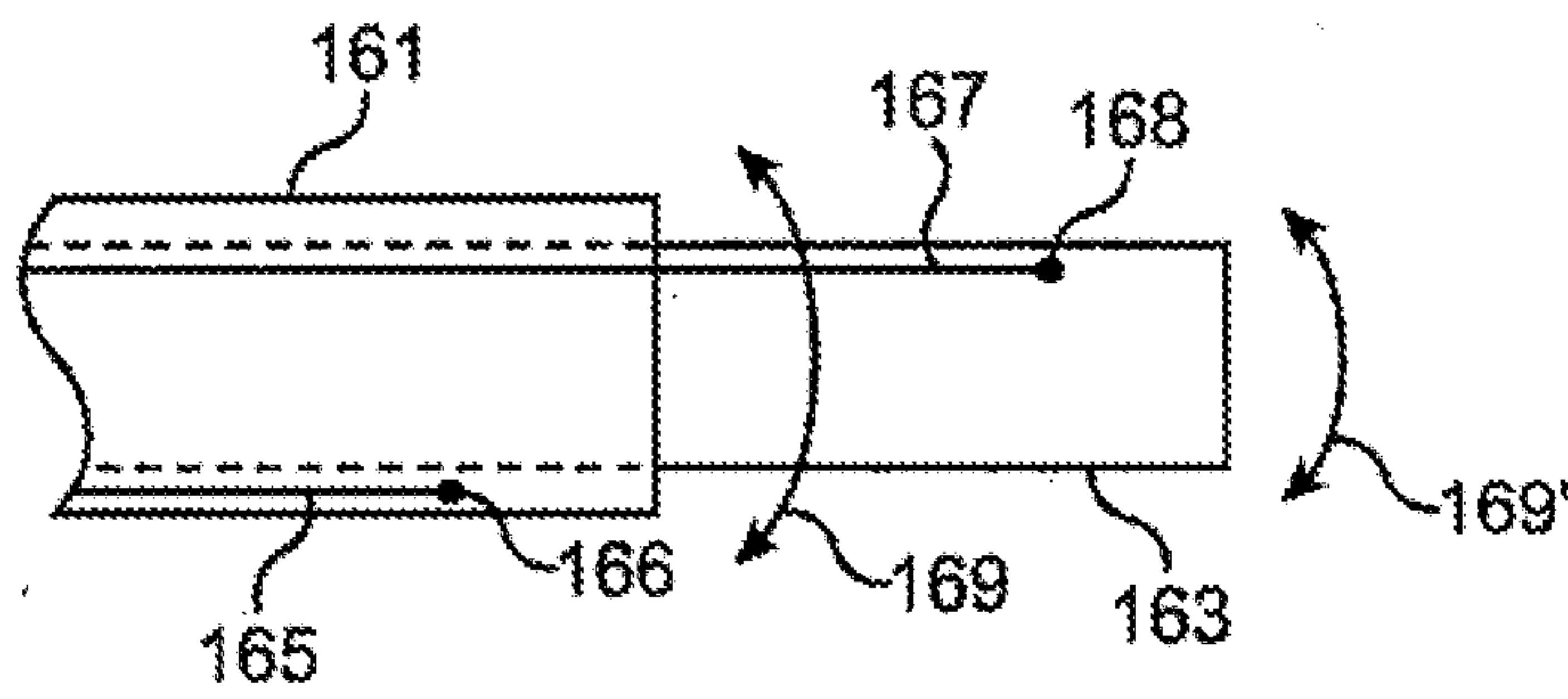

FIG. 37

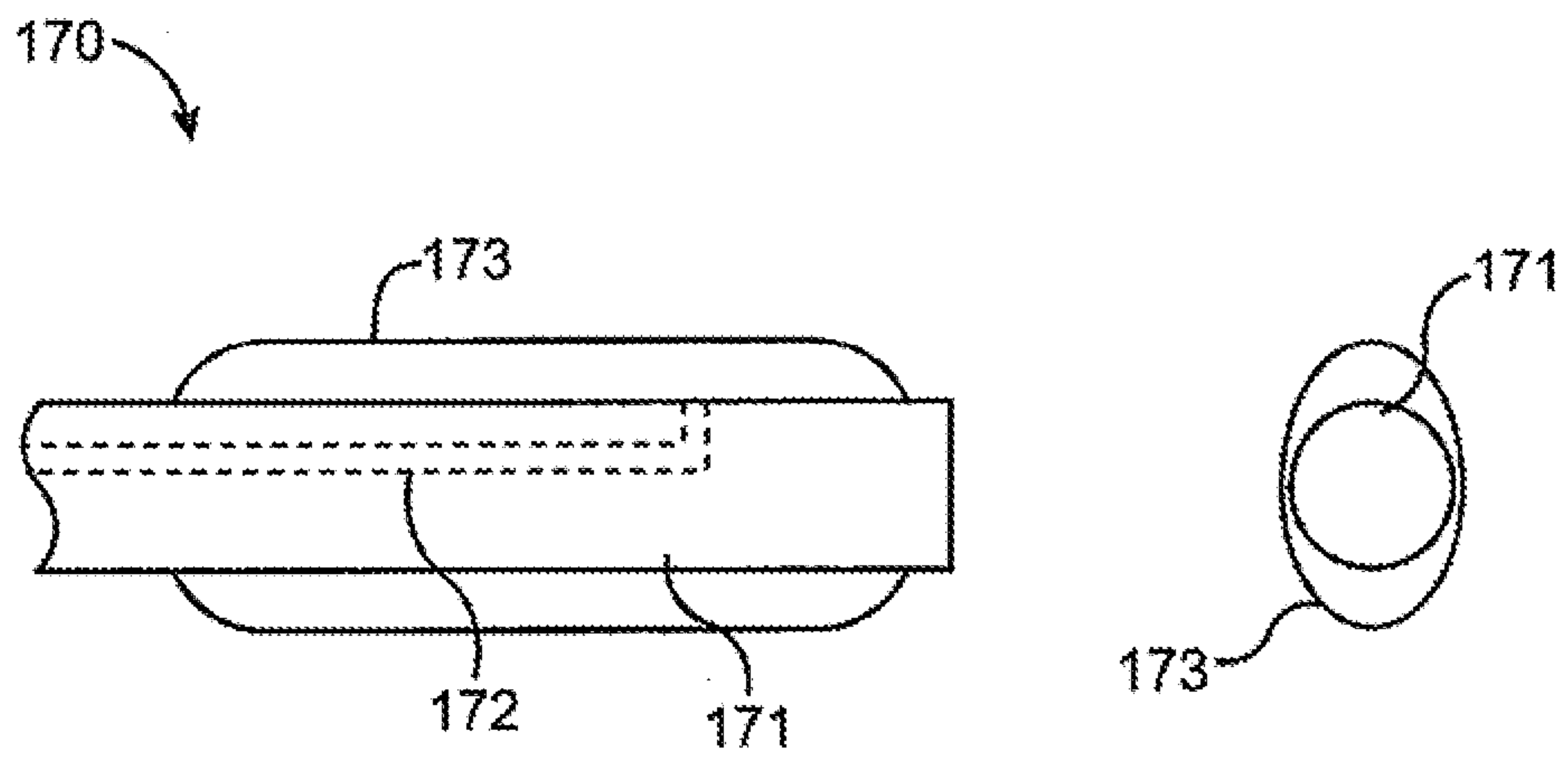

FIG. 38

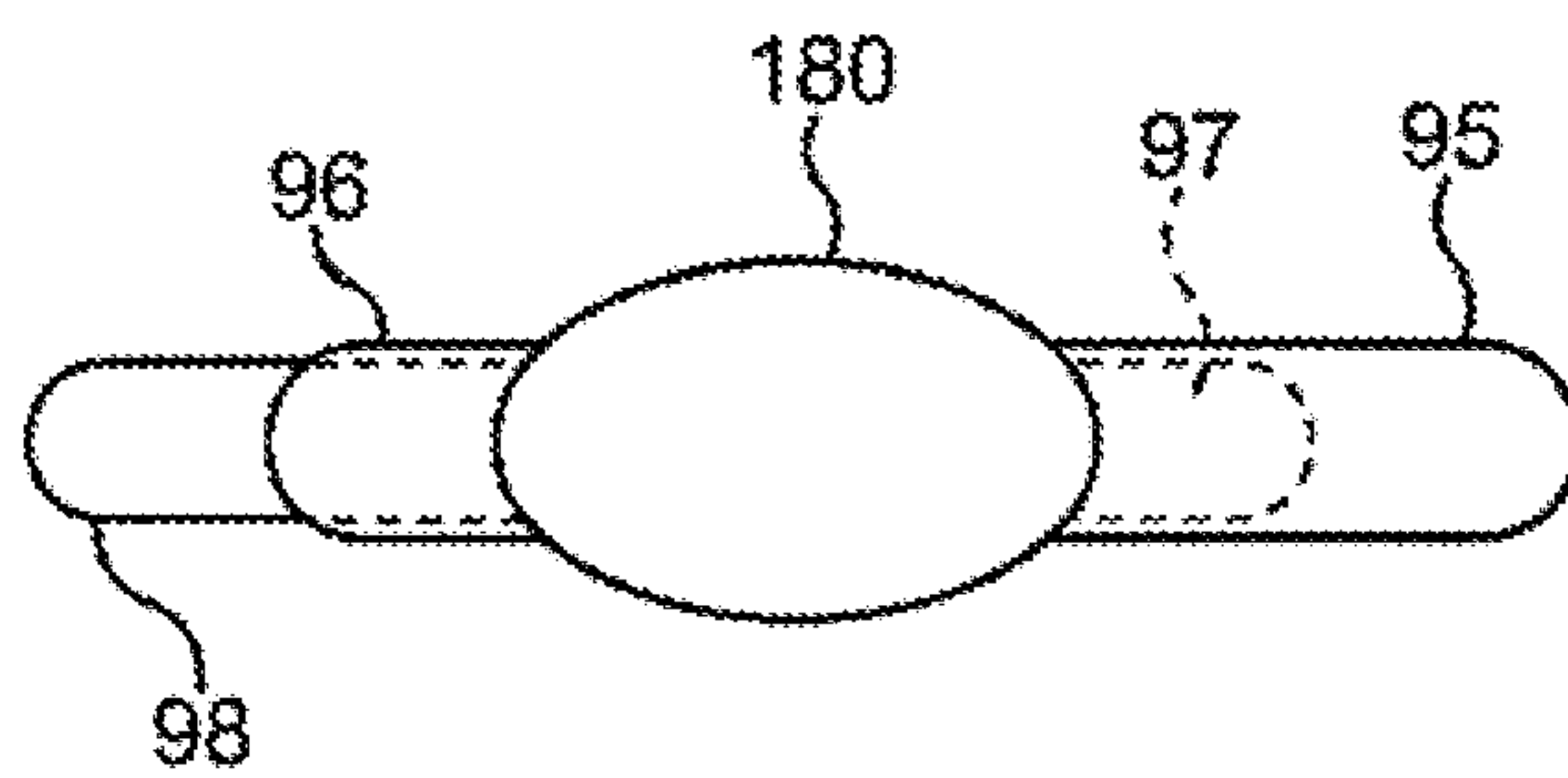

FIG. 39

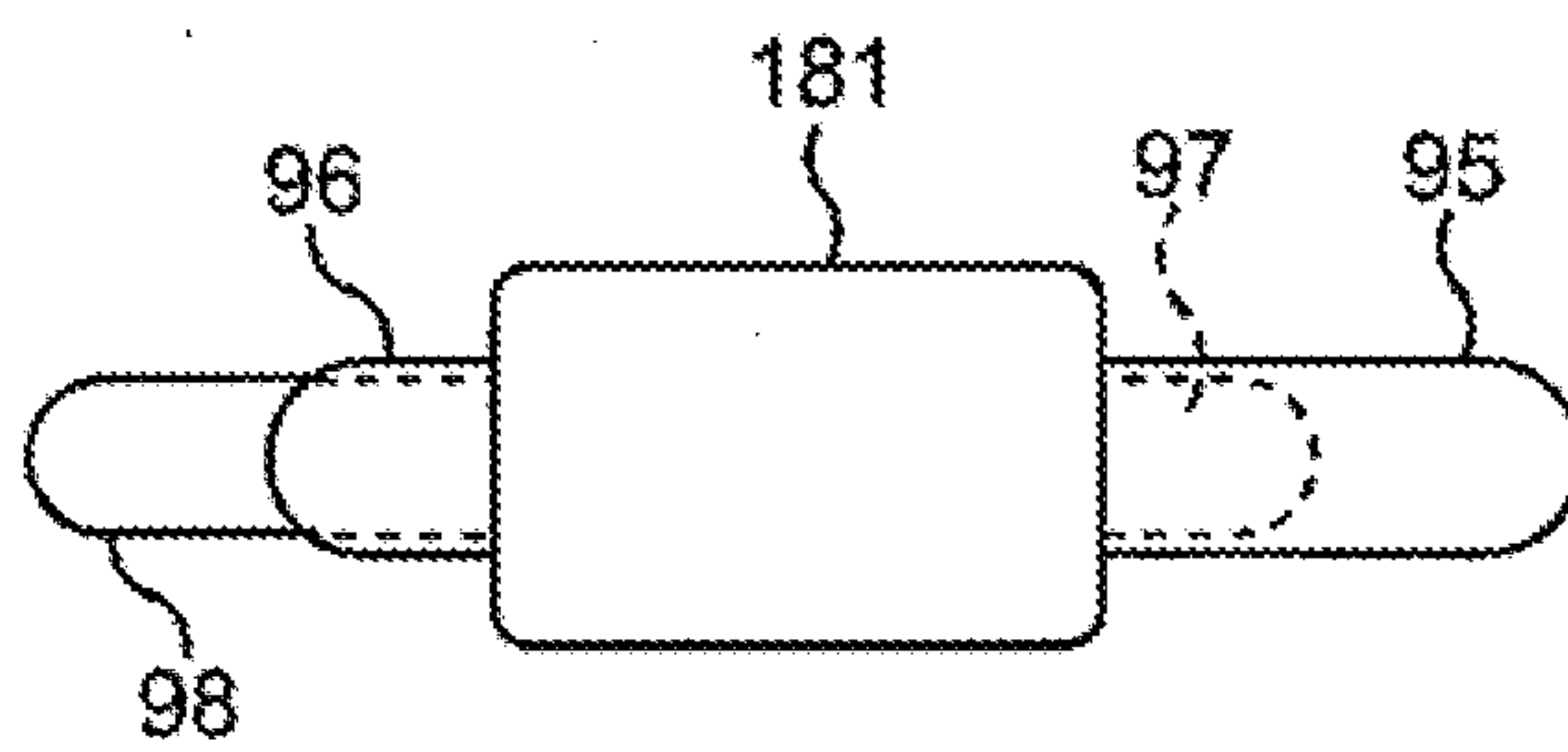

FIG. 40

