



- (51) **International Patent Classification:**
H04N 19/117 (2014.01) H04N 19/186 (2014.01)
- (21) **International Application Number:** PCT/US2020/050116
- (22) **International Filing Date:** 10 September 2020 (10.09.2020)
- (25) **Filing Language:** English
- (26) **Publication Language:** English
- (30) **Priority Data:**
62/901,118 16 September 2019 (16.09.2019) US
17/010,403 02 September 2020 (02.09.2020) US
- (71) **Applicant: TENCENT AMERICA LLC [US/US];** 2747 Park Boulevard, Palo Alto, California 94306 (US).
- (72) **Inventors: LI, Xiang;** c/o TENCENT AMERICA LLC, 2747 Park Boulevard, Palo Alto, California 94306 (US). **ZHAO, Xin;** c/o TENCENT AMERICA LLC, 2747 Park Boulevard, Palo Alto, California 94306 (US). **DU, Yixin;** c/o TENCENT AMERICA LLC, 2747 Park Boulevard, Palo Alto, California 94306 (US). **ZHAO, Liang;** c/o TENCENT AMERICA LLC, 2747 Park Boulevard, Palo Alto, California 94306 (US). **LIU, Shan;** c/o TENCENT AMERICA LLC, 2747 Park Boulevard, Palo Alto, California 94306 (US).
- (74) **Agent: MA, Johnny et al.;** Oblon, McClelland, Maier & Neustadt, L.L.P., 1940 Duke Street, Alexandria, Virginia 22314 (US).
- (81) **Designated States** (unless otherwise indicated, for every kind of national protection available): AE, AG, AL, AM, AO, AT, AU, AZ, BA, BB, BG, BH, BN, BR, BW, BY, BZ, CA, CH, CL, CN, CO, CR, CU, CZ, DE, DJ, DK, DM, DO, DZ, EC, EE, EG, ES, FI, GB, GD, GE, GH, GM, GT, HN, HR, HU, ID, IL, IN, IR, IS, IT, JO, JP, KE, KG, KH, KN, KP, KR, KW, KZ, LA, LC, LK, LR, LS, LU, LY, MA, MD, ME, MG, MK, MN, MW, MX, MY, MZ, NA, NG, NI, NO, NZ, OM, PA, PE, PG, PH, PL, PT, QA, RO, RS, RU, RW, SA, SC, SD, SE, SG, SK, SL, ST, SV, SY, TH, TJ, TM, TN, TR, TT, TZ, UA, UG, US, UZ, VC, VN, WS, ZA, ZM, ZW.
- (84) **Designated States** (unless otherwise indicated, for every kind of regional protection available): ARIPO (BW, GH, GM, KE, LR, LS, MW, MZ, NA, RW, SD, SL, ST, SZ, TZ, UG, ZM, ZW), Eurasian (AM, AZ, BY, KG, KZ, RU, TJ, TM), European (AL, AT, BE, BG, CH, CY, CZ, DE, DK, EE, ES, FI, FR, GB, GR, HR, HU, IE, IS, IT, LT, LU, LV, MC, MK, MT, NL, NO, PL, PT, RO, RS, SE, SI, SK, SM,

(54) **Title:** METHOD AND APPARATUS FOR CROSS-COMPONENT FILTERING

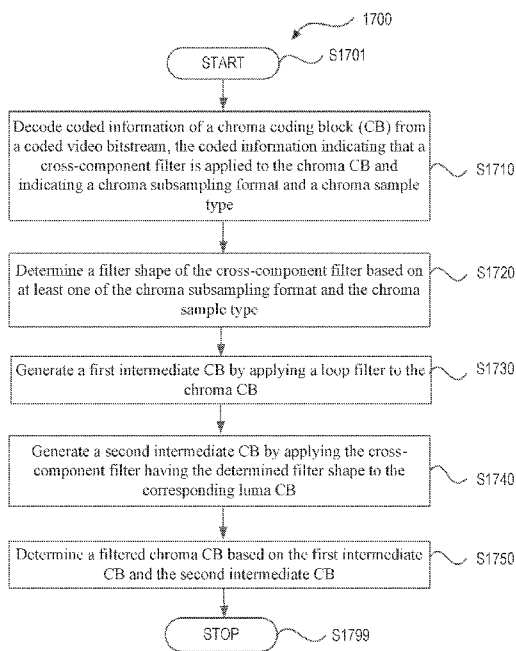

FIG. 17

(57) **Abstract:** Aspects of the disclosure provide a method and an apparatus including processing circuitry for video decoding. The processing circuitry decodes coded information of a chroma coding block (CB) from a coded video bitstream. The coded information indicates that a cross-component filter is applied to the chroma CB and indicates a chroma subsampling format and a chroma sample type. The processing circuitry determines a filter shape of the cross-component filter based on at least one of the chroma subsampling format and the chroma sample type. The processing circuitry generates a first intermediate CB by applying a loop filter to the chroma CB and generates a second intermediate CB by applying the cross-component filter having the determined filter shape to the corresponding luma CB. The processing circuitry determines a filtered chroma CB based on the first intermediate CB and the second intermediate CB.

WO 2021/055222 A1

TR), OAPI (BF, BJ, CF, CG, CI, CM, GA, GN, GQ, GW,
KM, ML, MR, NE, SN, TD, TG).

Published:

- *with international search report (Art. 21(3))*
- *before the expiration of the time limit for amending the claims and to be republished in the event of receipt of amendments (Rule 48.2(h))*

METHOD AND APPARATUS FOR CROSS-COMPONENT FILTERING

INCORPORATION BY REFERENCE

[0001] This present application claims the benefit of priority to U.S. Patent Application No. 17/010,403, "Method and Apparatus for Cross-Component Filtering" filed on September 2, 2020, which claims the benefit of priority to U.S. Provisional Application No. 62/901,118, "Of Cross-Component Adaptive Loop Filter" filed on September 16, 2019. The entire disclosures of the prior applications are hereby incorporated by reference in their entirety.

TECHNICAL FIELD

[0002] The present disclosure describes embodiments generally related to video coding.

BACKGROUND

[0003] The background description provided herein is for the purpose of generally presenting the context of the disclosure. Work of the presently named inventors, to the extent the work is described in this background section, as well as aspects of the description that may not otherwise qualify as prior art at the time of filing, are neither expressly nor impliedly admitted as prior art against the present disclosure.

[0004] Video coding and decoding can be performed using inter-picture prediction with motion compensation. Uncompressed digital video can include a series of pictures, each picture having a spatial dimension of, for example, 1920 x 1080 luminance samples and associated chrominance samples. The series of pictures can have a fixed or variable picture rate (informally also known as frame rate), of, for example 60 pictures per second or 60 Hz. Uncompressed video has specific bitrate requirements. For example, 1080p60 4:2:0 video at 8 bit per sample (1920x1080 luminance sample resolution at 60 Hz frame rate) requires close to 1.5 Gbit/s bandwidth. An hour of such video requires more than 600 GBytes of storage space.

[0005] One purpose of video coding and decoding can be the reduction of redundancy in the input video signal, through compression. Compression can help reduce the aforementioned bandwidth and/or storage space requirements, in some cases by two orders of magnitude or more. Both lossless compression and lossy compression, as well as a combination thereof can be employed. Lossless compression refers to techniques where an exact copy of the original signal can be reconstructed from the compressed original signal. When using lossy compression, the reconstructed signal may not be identical to the original signal, but the distortion between original and reconstructed signals is small enough to make the reconstructed signal useful for the

intended application. In the case of video, lossy compression is widely employed. The amount of distortion tolerated depends on the application; for example, users of certain consumer streaming applications may tolerate higher distortion than users of television distribution applications. The compression ratio achievable can reflect that: higher allowable/tolerable distortion can yield higher compression ratios.

[0006] A video encoder and decoder can utilize techniques from several broad categories, including, for example, motion compensation, transform, quantization, and entropy coding.

[0007] Video codec technologies can include techniques known as intra coding. In intra coding, sample values are represented without reference to samples or other data from previously reconstructed reference pictures. In some video codecs, the picture is spatially subdivided into blocks of samples. When all blocks of samples are coded in intra mode, that picture can be an intra picture. Intra pictures and their derivations such as independent decoder refresh pictures, can be used to reset the decoder state and can, therefore, be used as the first picture in a coded video bitstream and a video session, or as a still image. The samples of an intra block can be exposed to a transform, and the transform coefficients can be quantized before entropy coding. Intra prediction can be a technique that minimizes sample values in the pre-transform domain. In some cases, the smaller the DC value after a transform is, and the smaller the AC coefficients are, the fewer the bits that are required at a given quantization step size to represent the block after entropy coding.

[0008] Traditional intra coding such as known from, for example MPEG-2 generation coding technologies, does not use intra prediction. However, some newer video compression technologies include techniques that attempt, from, for example, surrounding sample data and/or metadata obtained during the encoding/decoding of spatially neighboring, and preceding in decoding order, blocks of data. Such techniques are henceforth called “intra prediction” techniques. Note that in at least some cases, intra prediction is using reference data only from the current picture under reconstruction and not from reference pictures.

[0009] There can be many different forms of intra prediction. When more than one of such techniques can be used in a given video coding technology, the technique in use can be coded in an intra prediction mode. In certain cases, modes can have submodes and/or parameters, and those can be coded individually or included in the mode codeword. Which codeword to use for a given mode/submode/parameter combination can have an impact in the

coding efficiency gain through intra prediction, and so can the entropy coding technology used to translate the codewords into a bitstream.

[0010] A certain mode of intra prediction was introduced with H.264, refined in H.265, and further refined in newer coding technologies such as joint exploration model (JEM), versatile video coding (VVC), and benchmark set (BMS). A predictor block can be formed using neighboring sample values belonging to already available samples. Sample values of neighboring samples are copied into the predictor block according to a direction. A reference to the direction in use can be coded in the bitstream or may itself be predicted.

[0011] Referring to FIG. 1A, depicted in the lower right is a subset of nine predictor directions known from H.265's 33 possible predictor directions (corresponding to the 33 angular modes of the 35 intra modes). The point where the arrows converge (101) represents the sample being predicted. The arrows represent the direction from which the sample is being predicted. For example, arrow (102) indicates that sample (101) is predicted from a sample or samples to the upper right, at a 45 degree angle from the horizontal. Similarly, arrow (103) indicates that sample (101) is predicted from a sample or samples to the lower left of sample (101), in a 22.5 degree angle from the horizontal.

[0012] Still referring to FIG. 1A, on the top left there is depicted a square block (104) of 4 x 4 samples (indicated by a dashed, boldface line). The square block (104) includes 16 samples, each labelled with an "S", its position in the Y dimension (e.g., row index) and its position in the X dimension (e.g., column index). For example, sample S21 is the second sample in the Y dimension (from the top) and the first (from the left) sample in the X dimension. Similarly, sample S44 is the fourth sample in block (104) in both the Y and X dimensions. As the block is 4 x 4 samples in size, S44 is at the bottom right. Further shown are reference samples that follow a similar numbering scheme. A reference sample is labelled with an R, its Y position (e.g., row index) and X position (column index) relative to block (104). In both H.264 and H.265, prediction samples neighbor the block under reconstruction; therefore no negative values need to be used.

[0013] Intra picture prediction can work by copying reference sample values from the neighboring samples as appropriated by the signaled prediction direction. For example, assume the coded video bitstream includes signaling that, for this block, indicates a prediction direction consistent with arrow (102)—that is, samples are predicted from a prediction sample or samples to the upper right, at a 45 degree angle from the horizontal. In that case, samples S41, S32, S23,

and S14 are predicted from the same reference sample R05. Sample S44 is then predicted from reference sample R08.

[0014] In certain cases, the values of multiple reference samples may be combined, for example through interpolation, in order to calculate a reference sample; especially when the directions are not evenly divisible by 45 degrees.

[0015] The number of possible directions has increased as video coding technology has developed. In H.264 (year 2003), nine different direction could be represented. That increased to 33 in H.265 (year 2013), and JEM/VVC/BMS, at the time of disclosure, can support up to 65 directions. Experiments have been conducted to identify the most likely directions, and certain techniques in the entropy coding are used to represent those likely directions in a small number of bits, accepting a certain penalty for less likely directions. Further, the directions themselves can sometimes be predicted from neighboring directions used in neighboring, already decoded, blocks.

[0016] FIG. 1B shows a schematic (180) that depicts 65 intra prediction directions according to JEM to illustrate the increasing number of prediction directions over time.

[0017] The mapping of intra prediction directions bits in the coded video bitstream that represent the direction can be different from video coding technology to video coding technology; and can range, for example, from simple direct mappings of prediction direction to intra prediction mode, to codewords, to complex adaptive schemes involving most probable modes, and similar techniques. In all cases, however, there can be certain directions that are statistically less likely to occur in video content than certain other directions. As the goal of video compression is the reduction of redundancy, those less likely directions will, in a well working video coding technology, be represented by a larger number of bits than more likely directions.

[0018] Motion compensation can be a lossy compression technique and can relate to techniques where a block of sample data from a previously reconstructed picture or part thereof (reference picture), after being spatially shifted in a direction indicated by a motion vector (MV henceforth), is used for the prediction of a newly reconstructed picture or picture part. In some cases, the reference picture can be the same as the picture currently under reconstruction. MVs can have two dimensions X and Y, or three dimensions, the third being an indication of the reference picture in use (the latter, indirectly, can be a time dimension).

[0019] In some video compression techniques, an MV applicable to a certain area of sample data can be predicted from other MVs, for example from those related to another area of sample data spatially adjacent to the area under reconstruction, and preceding that MV in decoding order. Doing so can substantially reduce the amount of data required for coding the MV, thereby removing redundancy and increasing compression. MV prediction can work effectively, for example, because when coding an input video signal derived from a camera (known as natural video) there is a statistical likelihood that areas larger than the area to which a single MV is applicable move in a similar direction and, therefore, can in some cases be predicted using a similar motion vector derived from MVs of neighboring area. That results in the MV found for a given area to be similar or the same as the MV predicted from the surrounding MVs, and that in turn can be represented, after entropy coding, in a smaller number of bits than what would be used if coding the MV directly. In some cases, MV prediction can be an example of lossless compression of a signal (namely: the MVs) derived from the original signal (namely: the sample stream). In other cases, MV prediction itself can be lossy, for example because of rounding errors when calculating a predictor from several surrounding MVs.

[0020] Various MV prediction mechanisms are described in H.265/HEVC (ITU-T Rec. H.265, "High Efficiency Video Coding", December 2016). Out of the many MV prediction mechanisms that H.265 offers, described here is a technique henceforth referred to as "spatial merge".

[0021] Referring to FIG. 2, a current block (201) comprises samples that have been found by the encoder during the motion search process to be predictable from a previous block of the same size that has been spatially shifted. Instead of coding that MV directly, the MV can be derived from metadata associated with one or more reference pictures, for example from the most recent (in decoding order) reference picture, using the MV associated with either one of five surrounding samples, denoted A0, A1, and B0, B1, B2 (202 through 206, respectively). In H.265, the MV prediction can use predictors from the same reference picture that the neighboring block is using.

SUMMARY

[0022] Aspects of the disclosure provide methods and apparatuses for video encoding/decoding. In some examples, an apparatus for video decoding includes processing circuitry. The processing circuitry can decode coded information of a chroma coding block (CB) from a coded video bitstream. The coded information can indicate that a cross-component filter

is applied to the chroma CB. The coded information can further indicate a chroma subsampling format and a chroma sample type that indicates a relative position of a chroma sample with respect to at least one luma sample in the a corresponding luma CB. The processing circuitry can determine a filter shape of the cross-component filter based on at least one of the chroma subsampling format and the chroma sample type. The processing circuitry can generate a first intermediate CB by applying a loop filter to the chroma CB. The processing circuitry can generate a second intermediate CB by applying the cross-component filter having the determined filter shape to the corresponding luma CB. The processing circuitry can determine a filtered chroma CB based on the first intermediate CB and the second intermediate CB.

[0023] In an example, the chroma sample type is signaled in the coded video bitstream.

[0024] In an example, a number of filter coefficients of the cross-component filter is signaled in the coded video bitstream. The processing circuitry can determine the filter shape of the cross-component filter based on the number of filter coefficients and the at least one of the chroma subsampling format and the chroma sample type.

[0025] In an example, the chroma subsampling format is 4:2:0. The at least one luma sample includes four luma samples that are a top-left sample, a top-right sample, a bottom-left sample, and a bottom-right sample. The chroma sample type is one of six chroma sample types 0-5 indicating six relative positions 0-5, respectively, and the six relative positions 0-5 of the chroma sample correspond to a left-center position between the top-left and the bottom-left samples, a center position of the four luma samples, a top left position co-located with the top-left sample, a top-center position between the top-left and the top-right samples, a bottom left position co-located with the bottom-left sample, and a bottom-center position between the bottom-left and the bottom-right samples, respectively. The processing circuitry can determine the filter shape of the cross-component filter based on the chroma sample type. In an example, the coded video bitstream includes a cross-component linear model (CCLM) flag indicating that the chroma sample type is 0 or 2.

[0026] In an example, the cross-component filter is a cross-component adaptive loop filter (CC-ALF) and the loop filter is an adaptive loop filter (ALF).

[0027] In an embodiment, a range of filter coefficients of the cross-component filter is less than or equal to K bits and K is a positive integer. In an example, the filter coefficients of the cross-component filter are coded using fixed-length coding. In an example, the processing circuitry can shift luma sample values of the corresponding luma CB to have a dynamic range of

8 bits based on the dynamic range of the luma sample values being larger than 8 bits where K is 8 bits. The processing circuitry can apply the cross-component filter having the determined filter shape to the shifted luma sample values.

[0028] In some examples, an apparatus for video decoding includes processing circuitry. The processing circuitry can decode coded information of a chroma CB from a coded video bitstream. The coded information can indicate that a cross-component filter is applied to the chroma CB based on a corresponding luma CB. The processing circuitry can generate a down-sampled luma CB by applying a down-sampling filter to the corresponding luma CB where a chroma horizontal subsampling factor and a chroma vertical subsampling factor between the chroma CB and the down-sampled luma CB is one. The processing circuitry can generate a first intermediate CB by applying a loop filter to the chroma CB. The processing circuitry can generate a second intermediate CB by applying the cross-component filter to the down-sampled luma CB where a filter shape of the cross-component filter is independent of a chroma subsampling format and a chroma sample type of the chroma CB. The chroma sample type can indicate a relative position of a chroma sample with respect to at least one luma sample in the corresponding luma CB. The processing circuitry can determine a filtered chroma CB based on the first intermediate CB and the second intermediate CB. In an example, the down-sampling filter corresponds to a filter applied to co-located luma samples in a CCLM mode. In an example, the down-sampling filter is a $\{1,2,1;1,2,1\}/8$ filter and the chroma subsampling format is 4:2:0. In an example, the filter shape of the cross-component filter is one of a 7×7 diamond shape, a 7×7 square shape, a 5×5 diamond shape, a 5×5 square shape, a 3×3 diamond shape, and a 3×3 square shape.

[0029] Aspects of the disclosure also provide a non-transitory computer-readable medium storing instructions which when executed by a computer for video decoding cause the computer to perform any of the methods for video decoding.

BRIEF DESCRIPTION OF THE DRAWINGS

[0030] Further features, the nature, and various advantages of the disclosed subject matter will be more apparent from the following detailed description and the accompanying drawings in which:

[0031] FIG. 1A is a schematic illustration of an exemplary subset of intra prediction modes.

[0032] FIG. 1B is an illustration of exemplary intra prediction directions.

[0033] FIG. 2 is a schematic illustration of a current block and its surrounding spatial merge candidates in one example.

[0034] FIG. 3 is a schematic illustration of a simplified block diagram of a communication system (300) in accordance with an embodiment.

[0035] FIG. 4 is a schematic illustration of a simplified block diagram of a communication system (400) in accordance with an embodiment.

[0036] FIG. 5 is a schematic illustration of a simplified block diagram of a decoder in accordance with an embodiment.

[0037] FIG. 6 is a schematic illustration of a simplified block diagram of an encoder in accordance with an embodiment.

[0038] FIG. 7 shows a block diagram of an encoder in accordance with another embodiment.

[0039] FIG. 8 shows a block diagram of a decoder in accordance with another embodiment.

[0040] FIG. 9 shows examples of filter shapes according to embodiments of the disclosure.

[0041] FIGs. 10A-10D show examples of subsampled positions used for calculating gradients according to embodiments of the disclosure.

[0042] FIGs. 11A-11B show examples of a virtual boundary filtering process according to embodiments of the disclosure.

[0043] FIGs. 12A-12F show examples of symmetric padding operations at virtual boundaries according to embodiments of the disclosure.

[0044] FIG. 13 shows an exemplary functional diagram for generating luma and chroma components according to an embodiment of the disclosure.

[0045] FIG. 14 shows an example of a filter 1400 according to an embodiment of the disclosure.

[0046] FIGs. 15A-15B show exemplary locations of chroma samples relative to luma samples according to embodiments of the disclosure.

[0047] FIG. 16 shows examples of filter shapes (1601)-(1603) of respective cross-component adaptive loop filters (CC-ALFs) according to embodiments of the disclosure.

[0048] FIG. 17 shows a flow chart outlining a process (1700) according to an embodiment of the disclosure.

[0049] FIG. 18 is a schematic illustration of a computer system in accordance with an embodiment.

DETAILED DESCRIPTION OF EMBODIMENTS

[0050] FIG. 3 illustrates a simplified block diagram of a communication system (300) according to an embodiment of the present disclosure. The communication system (300) includes a plurality of terminal devices that can communicate with each other, via, for example, a network (350). For example, the communication system (300) includes a first pair of terminal devices (310) and (320) interconnected via the network (350). In the FIG. 3 example, the first pair of terminal devices (310) and (320) performs unidirectional transmission of data. For example, the terminal device (310) may code video data (e.g., a stream of video pictures that are captured by the terminal device (310)) for transmission to the other terminal device (320) via the network (350). The encoded video data can be transmitted in the form of one or more coded video bitstreams. The terminal device (320) may receive the coded video data from the network (350), decode the coded video data to recover the video pictures and display video pictures according to the recovered video data. Unidirectional data transmission may be common in media serving applications and the like.

[0051] In another example, the communication system (300) includes a second pair of terminal devices (330) and (340) that performs bidirectional transmission of coded video data that may occur, for example, during videoconferencing. For bidirectional transmission of data, in an example, each terminal device of the terminal devices (330) and (340) may code video data (e.g., a stream of video pictures that are captured by the terminal device) for transmission to the other terminal device of the terminal devices (330) and (340) via the network (350). Each terminal device of the terminal devices (330) and (340) also may receive the coded video data transmitted by the other terminal device of the terminal devices (330) and (340), and may decode the coded video data to recover the video pictures and may display video pictures at an accessible display device according to the recovered video data.

[0052] In the FIG. 3 example, the terminal devices (310), (320), (330) and (340) may be illustrated as servers, personal computers and smart phones but the principles of the present disclosure may be not so limited. Embodiments of the present disclosure find application with laptop computers, tablet computers, media players and/or dedicated video conferencing equipment. The network (350) represents any number of networks that convey coded video data among the terminal devices (310), (320), (330) and (340), including for example wireline (wired)

and/or wireless communication networks. The communication network (350) may exchange data in circuit-switched and/or packet-switched channels. Representative networks include telecommunications networks, local area networks, wide area networks and/or the Internet. For the purposes of the present discussion, the architecture and topology of the network (350) may be immaterial to the operation of the present disclosure unless explained herein below.

[0053] FIG. 4 illustrates, as an example for an application for the disclosed subject matter, the placement of a video encoder and a video decoder in a streaming environment. The disclosed subject matter can be equally applicable to other video enabled applications, including, for example, video conferencing, digital TV, storing of compressed video on digital media including CD, DVD, memory stick and the like, and so on.

[0054] A streaming system may include a capture subsystem (413), that can include a video source (401), for example a digital camera, creating for example a stream of video pictures (402) that are uncompressed. In an example, the stream of video pictures (402) includes samples that are taken by the digital camera. The stream of video pictures (402), depicted as a bold line to emphasize a high data volume when compared to encoded video data (404) (or coded video bitstreams), can be processed by an electronic device (420) that includes a video encoder (403) coupled to the video source (401). The video encoder (403) can include hardware, software, or a combination thereof to enable or implement aspects of the disclosed subject matter as described in more detail below. The encoded video data (404) (or encoded video bitstream (404)), depicted as a thin line to emphasize the lower data volume when compared to the stream of video pictures (402), can be stored on a streaming server (405) for future use. One or more streaming client subsystems, such as client subsystems (406) and (408) in FIG. 4 can access the streaming server (405) to retrieve copies (407) and (409) of the encoded video data (404). A client subsystem (406) can include a video decoder (410), for example, in an electronic device (430). The video decoder (410) decodes the incoming copy (407) of the encoded video data and creates an outgoing stream of video pictures (411) that can be rendered on a display (412) (e.g., display screen) or other rendering device (not depicted). In some streaming systems, the encoded video data (404), (407), and (409) (e.g., video bitstreams) can be encoded according to certain video coding/compression standards. Examples of those standards include ITU-T Recommendation H.265. In an example, a video coding standard under development is informally known as Versatile Video Coding (VVC). The disclosed subject matter may be used in the context of VVC.

[0055] It is noted that the electronic devices (420) and (430) can include other components (not shown). For example, the electronic device (420) can include a video decoder (not shown) and the electronic device (430) can include a video encoder (not shown) as well.

[0056] FIG. 5 shows a block diagram of a video decoder (510) according to an embodiment of the present disclosure. The video decoder (510) can be included in an electronic device (530). The electronic device (530) can include a receiver (531) (e.g., receiving circuitry). The video decoder (510) can be used in the place of the video decoder (410) in the FIG. 4 example.

[0057] The receiver (531) may receive one or more coded video sequences to be decoded by the video decoder (510); in the same or another embodiment, one coded video sequence at a time, where the decoding of each coded video sequence is independent from other coded video sequences. The coded video sequence may be received from a channel (501), which may be a hardware/software link to a storage device which stores the encoded video data. The receiver (531) may receive the encoded video data with other data, for example, coded audio data and/or ancillary data streams, that may be forwarded to their respective using entities (not depicted). The receiver (531) may separate the coded video sequence from the other data. To combat network jitter, a buffer memory (515) may be coupled in between the receiver (531) and an entropy decoder / parser (520) ("parser (520)" henceforth). In certain applications, the buffer memory (515) is part of the video decoder (510). In others, it can be outside of the video decoder (510) (not depicted). In still others, there can be a buffer memory (not depicted) outside of the video decoder (510), for example to combat network jitter, and in addition another buffer memory (515) inside the video decoder (510), for example to handle playout timing. When the receiver (531) is receiving data from a store/forward device of sufficient bandwidth and controllability, or from an isosynchronous network, the buffer memory (515) may not be needed, or can be small. For use on best effort packet networks such as the Internet, the buffer memory (515) may be required, can be comparatively large and can be advantageously of adaptive size, and may at least partially be implemented in an operating system or similar elements (not depicted) outside of the video decoder (510).

[0058] The video decoder (510) may include the parser (520) to reconstruct symbols (521) from the coded video sequence. Categories of those symbols include information used to manage operation of the video decoder (510), and potentially information to control a rendering device such as a render device (512) (e.g., a display screen) that is not an integral part of the

electronic device (530) but can be coupled to the electronic device (530), as was shown in FIG. 5. The control information for the rendering device(s) may be in the form of Supplemental Enhancement Information (SEI messages) or Video Usability Information (VUI) parameter set fragments (not depicted). The parser (520) may parse / entropy-decode the coded video sequence that is received. The coding of the coded video sequence can be in accordance with a video coding technology or standard, and can follow various principles, including variable length coding, Huffman coding, arithmetic coding with or without context sensitivity, and so forth. The parser (520) may extract from the coded video sequence, a set of subgroup parameters for at least one of the subgroups of pixels in the video decoder, based upon at least one parameter corresponding to the group. Subgroups can include Groups of Pictures (GOPs), pictures, tiles, slices, macroblocks, Coding Units (CUs), blocks, Transform Units (TUs), Prediction Units (PUs) and so forth. The parser (520) may also extract from the coded video sequence information such as transform coefficients, quantizer parameter values, motion vectors, and so forth.

[0059] The parser (520) may perform an entropy decoding / parsing operation on the video sequence received from the buffer memory (515), so as to create symbols (521).

[0060] Reconstruction of the symbols (521) can involve multiple different units depending on the type of the coded video picture or parts thereof (such as: inter and intra picture, inter and intra block), and other factors. Which units are involved, and how, can be controlled by the subgroup control information that was parsed from the coded video sequence by the parser (520). The flow of such subgroup control information between the parser (520) and the multiple units below is not depicted for clarity.

[0061] Beyond the functional blocks already mentioned, the video decoder (510) can be conceptually subdivided into a number of functional units as described below. In a practical implementation operating under commercial constraints, many of these units interact closely with each other and can, at least partly, be integrated into each other. However, for the purpose of describing the disclosed subject matter, the conceptual subdivision into the functional units below is appropriate.

[0062] A first unit is the scaler / inverse transform unit (551). The scaler / inverse transform unit (551) receives a quantized transform coefficient as well as control information, including which transform to use, block size, quantization factor, quantization scaling matrices, etc. as symbol(s) (521) from the parser (520). The scaler / inverse transform unit (551) can output blocks comprising sample values, that can be input into aggregator (555).

[0063] In some cases, the output samples of the scaler / inverse transform (551) can pertain to an intra coded block; that is: a block that is not using predictive information from previously reconstructed pictures, but can use predictive information from previously reconstructed parts of the current picture. Such predictive information can be provided by an intra picture prediction unit (552). In some cases, the intra picture prediction unit (552) generates a block of the same size and shape of the block under reconstruction, using surrounding already reconstructed information fetched from the current picture buffer (558). The current picture buffer (558) buffers, for example, partly reconstructed current picture and/or fully reconstructed current picture. The aggregator (555), in some cases, adds, on a per sample basis, the prediction information the intra prediction unit (552) has generated to the output sample information as provided by the scaler / inverse transform unit (551).

[0064] In other cases, the output samples of the scaler / inverse transform unit (551) can pertain to an inter coded, and potentially motion compensated block. In such a case, a motion compensation prediction unit (553) can access reference picture memory (557) to fetch samples used for prediction. After motion compensating the fetched samples in accordance with the symbols (521) pertaining to the block, these samples can be added by the aggregator (555) to the output of the scaler / inverse transform unit (551) (in this case called the residual samples or residual signal) so as to generate output sample information. The addresses within the reference picture memory (557) from where the motion compensation prediction unit (553) fetches prediction samples can be controlled by motion vectors, available to the motion compensation prediction unit (553) in the form of symbols (521) that can have, for example X, Y, and reference picture components. Motion compensation also can include interpolation of sample values as fetched from the reference picture memory (557) when sub-sample exact motion vectors are in use, motion vector prediction mechanisms, and so forth.

[0065] The output samples of the aggregator (555) can be subject to various loop filtering techniques in the loop filter unit (556). Video compression technologies can include in-loop filter technologies that are controlled by parameters included in the coded video sequence (also referred to as coded video bitstream) and made available to the loop filter unit (556) as symbols (521) from the parser (520), but can also be responsive to meta-information obtained during the decoding of previous (in decoding order) parts of the coded picture or coded video sequence, as well as responsive to previously reconstructed and loop-filtered sample values.

[0066] The output of the loop filter unit (556) can be a sample stream that can be output to the render device (512) as well as stored in the reference picture memory (557) for use in future inter-picture prediction.

[0067] Certain coded pictures, once fully reconstructed, can be used as reference pictures for future prediction. For example, once a coded picture corresponding to a current picture is fully reconstructed and the coded picture has been identified as a reference picture (by, for example, the parser (520)), the current picture buffer (558) can become a part of the reference picture memory (557), and a fresh current picture buffer can be reallocated before commencing the reconstruction of the following coded picture.

[0068] The video decoder (510) may perform decoding operations according to a predetermined video compression technology in a standard, such as ITU-T Rec. H.265. The coded video sequence may conform to a syntax specified by the video compression technology or standard being used, in the sense that the coded video sequence adheres to both the syntax of the video compression technology or standard and the profiles as documented in the video compression technology or standard. Specifically, a profile can select certain tools as the only tools available for use under that profile from all the tools available in the video compression technology or standard. Also necessary for compliance can be that the complexity of the coded video sequence is within bounds as defined by the level of the video compression technology or standard. In some cases, levels restrict the maximum picture size, maximum frame rate, maximum reconstruction sample rate (measured in, for example megasamples per second), maximum reference picture size, and so on. Limits set by levels can, in some cases, be further restricted through Hypothetical Reference Decoder (HRD) specifications and metadata for HRD buffer management signaled in the coded video sequence.

[0069] In an embodiment, the receiver (531) may receive additional (redundant) data with the encoded video. The additional data may be included as part of the coded video sequence(s). The additional data may be used by the video decoder (510) to properly decode the data and/or to more accurately reconstruct the original video data. Additional data can be in the form of, for example, temporal, spatial, or signal noise ratio (SNR) enhancement layers, redundant slices, redundant pictures, forward error correction codes, and so on.

[0070] FIG. 6 shows a block diagram of a video encoder (603) according to an embodiment of the present disclosure. The video encoder (603) is included in an electronic device (620). The electronic device (620) includes a transmitter (640) (e.g., transmitting

circuitry). The video encoder (603) can be used in the place of the video encoder (403) in the FIG. 4 example.

[0071] The video encoder (603) may receive video samples from a video source (601) (that is not part of the electronic device (620) in the FIG. 6 example) that may capture video image(s) to be coded by the video encoder (603). In another example, the video source (601) is a part of the electronic device (620).

[0072] The video source (601) may provide the source video sequence to be coded by the video encoder (603) in the form of a digital video sample stream that can be of any suitable bit depth (for example: 8 bit, 10 bit, 12 bit, ...), any color space (for example, BT.601 Y CrCb, RGB, ...), and any suitable sampling structure (for example Y CrCb 4:2:0, Y CrCb 4:4:4). In a media serving system, the video source (601) may be a storage device storing previously prepared video. In a videoconferencing system, the video source (601) may be a camera that captures local image information as a video sequence. Video data may be provided as a plurality of individual pictures that impart motion when viewed in sequence. The pictures themselves may be organized as a spatial array of pixels, wherein each pixel can comprise one or more samples depending on the sampling structure, color space, etc. in use. A person skilled in the art can readily understand the relationship between pixels and samples. The description below focuses on samples.

[0073] According to an embodiment, the video encoder (603) may code and compress the pictures of the source video sequence into a coded video sequence (643) in real time or under any other time constraints as required by the application. Enforcing appropriate coding speed is one function of a controller (650). In some embodiments, the controller (650) controls other functional units as described below and is functionally coupled to the other functional units. The coupling is not depicted for clarity. Parameters set by the controller (650) can include rate control related parameters (picture skip, quantizer, lambda value of rate-distortion optimization techniques, ...), picture size, group of pictures (GOP) layout, maximum motion vector search range, and so forth. The controller (650) can be configured to have other suitable functions that pertain to the video encoder (603) optimized for a certain system design.

[0074] In some embodiments, the video encoder (603) is configured to operate in a coding loop. As an oversimplified description, in an example, the coding loop can include a source coder (630) (e.g., responsible for creating symbols, such as a symbol stream, based on an input picture to be coded, and a reference picture(s)), and a (local) decoder (633) embedded in

the video encoder (603). The decoder (633) reconstructs the symbols to create the sample data in a similar manner as a (remote) decoder also would create (as any compression between symbols and coded video bitstream is lossless in the video compression technologies considered in the disclosed subject matter). The reconstructed sample stream (sample data) is input to the reference picture memory (634). As the decoding of a symbol stream leads to bit-exact results independent of decoder location (local or remote), the content in the reference picture memory (634) is also bit exact between the local encoder and remote encoder. In other words, the prediction part of an encoder "sees" as reference picture samples exactly the same sample values as a decoder would "see" when using prediction during decoding. This fundamental principle of reference picture synchronicity (and resulting drift, if synchronicity cannot be maintained, for example because of channel errors) is used in some related arts as well.

[0075] The operation of the "local" decoder (633) can be the same as of a "remote" decoder, such as the video decoder (510), which has already been described in detail above in conjunction with FIG. 5. Briefly referring also to FIG. 5, however, as symbols are available and encoding/decoding of symbols to a coded video sequence by an entropy coder (645) and the parser (520) can be lossless, the entropy decoding parts of the video decoder (510), including the buffer memory (515), and parser (520) may not be fully implemented in the local decoder (633).

[0076] An observation that can be made at this point is that any decoder technology except the parsing/entropy decoding that is present in a decoder also necessarily needs to be present, in substantially identical functional form, in a corresponding encoder. For this reason, the disclosed subject matter focuses on decoder operation. The description of encoder technologies can be abbreviated as they are the inverse of the comprehensively described decoder technologies. Only in certain areas a more detail description is required and provided below.

[0077] During operation, in some examples, the source coder (630) may perform motion compensated predictive coding, which codes an input picture predictively with reference to one or more previously coded picture from the video sequence that were designated as "reference pictures." In this manner, the coding engine (632) codes differences between pixel blocks of an input picture and pixel blocks of reference picture(s) that may be selected as prediction reference(s) to the input picture.

[0078] The local video decoder (633) may decode coded video data of pictures that may be designated as reference pictures, based on symbols created by the source coder (630).

Operations of the coding engine (632) may advantageously be lossy processes. When the coded video data may be decoded at a video decoder (not shown in FIG. 6), the reconstructed video sequence typically may be a replica of the source video sequence with some errors. The local video decoder (633) replicates decoding processes that may be performed by the video decoder on reference pictures and may cause reconstructed reference pictures to be stored in the reference picture cache (634). In this manner, the video encoder (603) may store copies of reconstructed reference pictures locally that have common content as the reconstructed reference pictures that will be obtained by a far-end video decoder (absent transmission errors).

[0079] The predictor (635) may perform prediction searches for the coding engine (632). That is, for a new picture to be coded, the predictor (635) may search the reference picture memory (634) for sample data (as candidate reference pixel blocks) or certain metadata such as reference picture motion vectors, block shapes, and so on, that may serve as an appropriate prediction reference for the new pictures. The predictor (635) may operate on a sample block-by-pixel block basis to find appropriate prediction references. In some cases, as determined by search results obtained by the predictor (635), an input picture may have prediction references drawn from multiple reference pictures stored in the reference picture memory (634).

[0080] The controller (650) may manage coding operations of the source coder (630), including, for example, setting of parameters and subgroup parameters used for encoding the video data.

[0081] Output of all aforementioned functional units may be subjected to entropy coding in the entropy coder (645). The entropy coder (645) translates the symbols as generated by the various functional units into a coded video sequence, by lossless compressing the symbols according to technologies such as Huffman coding, variable length coding, arithmetic coding, and so forth.

[0082] The transmitter (640) may buffer the coded video sequence(s) as created by the entropy coder (645) to prepare for transmission via a communication channel (660), which may be a hardware/software link to a storage device which would store the encoded video data. The transmitter (640) may merge coded video data from the video coder (603) with other data to be transmitted, for example, coded audio data and/or ancillary data streams (sources not shown).

[0083] The controller (650) may manage operation of the video encoder (603). During coding, the controller (650) may assign to each coded picture a certain coded picture type, which

may affect the coding techniques that may be applied to the respective picture. For example, pictures often may be assigned as one of the following picture types:

[0084] An Intra Picture (I picture) may be one that may be coded and decoded without using any other picture in the sequence as a source of prediction. Some video codecs allow for different types of intra pictures, including, for example Independent Decoder Refresh (“IDR”) Pictures. A person skilled in the art is aware of those variants of I pictures and their respective applications and features.

[0085] A predictive picture (P picture) may be one that may be coded and decoded using intra prediction or inter prediction using at most one motion vector and reference index to predict the sample values of each block.

[0086] A bi-directionally predictive picture (B Picture) may be one that may be coded and decoded using intra prediction or inter prediction using at most two motion vectors and reference indices to predict the sample values of each block. Similarly, multiple-predictive pictures can use more than two reference pictures and associated metadata for the reconstruction of a single block.

[0087] Source pictures commonly may be subdivided spatially into a plurality of sample blocks (for example, blocks of 4x4, 8x8, 4x8, or 16x16 samples each) and coded on a block-by-block basis. Blocks may be coded predictively with reference to other (already coded) blocks as determined by the coding assignment applied to the blocks' respective pictures. For example, blocks of I pictures may be coded non-predictively or they may be coded predictively with reference to already coded blocks of the same picture (spatial prediction or intra prediction). Pixel blocks of P pictures may be coded predictively, via spatial prediction or via temporal prediction with reference to one previously coded reference picture. Blocks of B pictures may be coded predictively, via spatial prediction or via temporal prediction with reference to one or two previously coded reference pictures.

[0088] The video encoder (603) may perform coding operations according to a predetermined video coding technology or standard, such as ITU-T Rec. H.265. In its operation, the video encoder (603) may perform various compression operations, including predictive coding operations that exploit temporal and spatial redundancies in the input video sequence. The coded video data, therefore, may conform to a syntax specified by the video coding technology or standard being used.

[0089] In an embodiment, the transmitter (640) may transmit additional data with the encoded video. The source coder (630) may include such data as part of the coded video sequence. Additional data may comprise temporal/spatial/SNR enhancement layers, other forms of redundant data such as redundant pictures and slices, SEI messages, VUI parameter set fragments, and so on.

[0090] A video may be captured as a plurality of source pictures (video pictures) in a temporal sequence. Intra-picture prediction (often abbreviated to intra prediction) makes use of spatial correlation in a given picture, and inter-picture prediction makes uses of the (temporal or other) correlation between the pictures. In an example, a specific picture under encoding/decoding, which is referred to as a current picture, is partitioned into blocks. When a block in the current picture is similar to a reference block in a previously coded and still buffered reference picture in the video, the block in the current picture can be coded by a vector that is referred to as a motion vector. The motion vector points to the reference block in the reference picture, and can have a third dimension identifying the reference picture, in case multiple reference pictures are in use.

[0091] In some embodiments, a bi-prediction technique can be used in the inter-picture prediction. According to the bi-prediction technique, two reference pictures, such as a first reference picture and a second reference picture that are both prior in decoding order to the current picture in the video (but may be in the past and future, respectively, in display order) are used. A block in the current picture can be coded by a first motion vector that points to a first reference block in the first reference picture, and a second motion vector that points to a second reference block in the second reference picture. The block can be predicted by a combination of the first reference block and the second reference block.

[0092] Further, a merge mode technique can be used in the inter-picture prediction to improve coding efficiency.

[0093] According to some embodiments of the disclosure, predictions, such as inter-picture predictions and intra-picture predictions are performed in the unit of blocks. For example, according to the HEVC standard, a picture in a sequence of video pictures is partitioned into coding tree units (CTU) for compression, the CTUs in a picture have the same size, such as 64x64 pixels, 32x32 pixels, or 16x16 pixels. In general, a CTU includes three coding tree blocks (CTBs), which are one luma CTB and two chroma CTBs. Each CTU can be recursively quadtree split into one or multiple coding units (CUs). For example, a CTU of 64x64

pixels can be split into one CU of 64x64 pixels, or 4 CUs of 32x32 pixels, or 16 CUs of 16x16 pixels. In an example, each CU is analyzed to determine a prediction type for the CU, such as an inter prediction type or an intra prediction type. The CU is split into one or more prediction units (PUs) depending on the temporal and/or spatial predictability. Generally, each PU includes a luma prediction block (PB), and two chroma PBs. In an embodiment, a prediction operation in coding (encoding/decoding) is performed in the unit of a prediction block. Using a luma prediction block as an example of a prediction block, the prediction block includes a matrix of values (e.g., luma values) for pixels, such as 8x8 pixels, 16x16 pixels, 8x16 pixels, 16x8 pixels, and the like.

[0094] FIG. 7 shows a diagram of a video encoder (703) according to another embodiment of the disclosure. The video encoder (703) is configured to receive a processing block (e.g., a prediction block) of sample values within a current video picture in a sequence of video pictures, and encode the processing block into a coded picture that is part of a coded video sequence. In an example, the video encoder (703) is used in the place of the video encoder (403) in the FIG. 4 example.

[0095] In an HEVC example, the video encoder (703) receives a matrix of sample values for a processing block, such as a prediction block of 8x8 samples, and the like. The video encoder (703) determines whether the processing block is best coded using intra mode, inter mode, or bi-prediction mode using, for example, rate-distortion optimization. When the processing block is to be coded in intra mode, the video encoder (703) may use an intra prediction technique to encode the processing block into the coded picture; and when the processing block is to be coded in inter mode or bi-prediction mode, the video encoder (703) may use an inter prediction or bi-prediction technique, respectively, to encode the processing block into the coded picture. In certain video coding technologies, merge mode can be an inter picture prediction submode where the motion vector is derived from one or more motion vector predictors without the benefit of a coded motion vector component outside the predictors. In certain other video coding technologies, a motion vector component applicable to the subject block may be present. In an example, the video encoder (703) includes other components, such as a mode decision module (not shown) to determine the mode of the processing blocks.

[0096] In the FIG. 7 example, the video encoder (703) includes the inter encoder (730), an intra encoder (722), a residue calculator (723), a switch (726), a residue encoder (724), a general controller (721), and an entropy encoder (725) coupled together as shown in FIG. 7.

[0097] The inter encoder (730) is configured to receive the samples of the current block (e.g., a processing block), compare the block to one or more reference blocks in reference pictures (e.g., blocks in previous pictures and later pictures), generate inter prediction information (e.g., description of redundant information according to inter encoding technique, motion vectors, merge mode information), and calculate inter prediction results (e.g., predicted block) based on the inter prediction information using any suitable technique. In some examples, the reference pictures are decoded reference pictures that are decoded based on the encoded video information.

[0098] The intra encoder (722) is configured to receive the samples of the current block (e.g., a processing block), in some cases compare the block to blocks already coded in the same picture, generate quantized coefficients after transform, and in some cases also intra prediction information (e.g., an intra prediction direction information according to one or more intra encoding techniques). In an example, the intra encoder (722) also calculates intra prediction results (e.g., predicted block) based on the intra prediction information and reference blocks in the same picture.

[0099] The general controller (721) is configured to determine general control data and control other components of the video encoder (703) based on the general control data. In an example, the general controller (721) determines the mode of the block, and provides a control signal to the switch (726) based on the mode. For example, when the mode is the intra mode, the general controller (721) controls the switch (726) to select the intra mode result for use by the residue calculator (723), and controls the entropy encoder (725) to select the intra prediction information and include the intra prediction information in the bitstream; and when the mode is the inter mode, the general controller (721) controls the switch (726) to select the inter prediction result for use by the residue calculator (723), and controls the entropy encoder (725) to select the inter prediction information and include the inter prediction information in the bitstream.

[0100] The residue calculator (723) is configured to calculate a difference (residue data) between the received block and prediction results selected from the intra encoder (722) or the inter encoder (730). The residue encoder (724) is configured to operate based on the residue data to encode the residue data to generate the transform coefficients. In an example, the residue encoder (724) is configured to convert the residue data from a spatial domain to a frequency domain, and generate the transform coefficients. The transform coefficients are then subject to quantization processing to obtain quantized transform coefficients. In various embodiments, the

video encoder (703) also includes a residue decoder (728). The residue decoder (728) is configured to perform inverse-transform, and generate the decoded residue data. The decoded residue data can be suitably used by the intra encoder (722) and the inter encoder (730). For example, the inter encoder (730) can generate decoded blocks based on the decoded residue data and inter prediction information, and the intra encoder (722) can generate decoded blocks based on the decoded residue data and the intra prediction information. The decoded blocks are suitably processed to generate decoded pictures and the decoded pictures can be buffered in a memory circuit (not shown) and used as reference pictures in some examples.

[0101] The entropy encoder (725) is configured to format the bitstream to include the encoded block. The entropy encoder (725) is configured to include various information according to a suitable standard, such as the HEVC standard. In an example, the entropy encoder (725) is configured to include the general control data, the selected prediction information (e.g., intra prediction information or inter prediction information), the residue information, and other suitable information in the bitstream. Note that, according to the disclosed subject matter, when coding a block in the merge submode of either inter mode or bi-prediction mode, there is no residue information.

[0102] FIG. 8 shows a diagram of a video decoder (810) according to another embodiment of the disclosure. The video decoder (810) is configured to receive coded pictures that are part of a coded video sequence, and decode the coded pictures to generate reconstructed pictures. In an example, the video decoder (810) is used in the place of the video decoder (410) in the FIG. 4 example.

[0103] In the FIG. 8 example, the video decoder (810) includes an entropy decoder (871), an inter decoder (880), a residue decoder (873), a reconstruction module (874), and an intra decoder (872) coupled together as shown in FIG. 8.

[0104] The entropy decoder (871) can be configured to reconstruct, from the coded picture, certain symbols that represent the syntax elements of which the coded picture is made up. Such symbols can include, for example, the mode in which a block is coded (such as, for example, intra mode, inter mode, bi-predicted mode, the latter two in merge submode or another submode), prediction information (such as, for example, intra prediction information or inter prediction information) that can identify certain sample or metadata that is used for prediction by the intra decoder (872) or the inter decoder (880), respectively, residual information in the form of, for example, quantized transform coefficients, and the like. In an example, when the

prediction mode is inter or bi-predicted mode, the inter prediction information is provided to the inter decoder (880); and when the prediction type is the intra prediction type, the intra prediction information is provided to the intra decoder (872). The residual information can be subject to inverse quantization and is provided to the residue decoder (873).

[0105] The inter decoder (880) is configured to receive the inter prediction information, and generate inter prediction results based on the inter prediction information.

[0106] The intra decoder (872) is configured to receive the intra prediction information, and generate prediction results based on the intra prediction information.

[0107] The residue decoder (873) is configured to perform inverse quantization to extract de-quantized transform coefficients, and process the de-quantized transform coefficients to convert the residual from the frequency domain to the spatial domain. The residue decoder (873) may also require certain control information (to include the Quantizer Parameter (QP)), and that information may be provided by the entropy decoder (871) (data path not depicted as this may be low volume control information only).

[0108] The reconstruction module (874) is configured to combine, in the spatial domain, the residual as output by the residue decoder (873) and the prediction results (as output by the inter or intra prediction modules as the case may be) to form a reconstructed block, that may be part of the reconstructed picture, which in turn may be part of the reconstructed video. It is noted that other suitable operations, such as a deblocking operation and the like, can be performed to improve the visual quality.

[0109] It is noted that the video encoders (403), (603), and (703), and the video decoders (410), (510), and (810) can be implemented using any suitable technique. In an embodiment, the video encoders (403), (603), and (703), and the video decoders (410), (510), and (810) can be implemented using one or more integrated circuits. In another embodiment, the video encoders (403), (603), and (603), and the video decoders (410), (510), and (810) can be implemented using one or more processors that execute software instructions.

[0110] An Adaptive Loop Filter (ALF) with block-based filter adaption can be applied by encoders/decoders to reduce artifacts. For a luma component, one of a plurality of filters (e.g., 25 filters) can be selected for a 4×4 luma block, for example, based on a direction and activity of local gradients.

[0111] An ALF can have any suitable shape and size. Referring to FIG. 9, ALFs (910)-(911) have a diamond shape, such as a 5×5 diamond-shape for the ALF (910) and a 7×7

diamond-shape for the ALF (911). In the ALF (910), elements (920)-(932) can be used in the filtering process and form a diamond shape. Seven values (e.g., C0-C6) can be used for the elements (920)-(932). In the ALF (911), elements (940)-(964) can be used in the filtering process and form a diamond shape. Thirteen values (e.g., C0-C12) can be used for the elements (940)-(964).

[0112] Referring to FIG. 9, in some examples, the two ALFs (910)-(911) with the diamond filter shape are used. The 5×5 diamond-shaped filter (910) can be applied for chroma components (e.g., chroma blocks, chroma CBs), and the 7×7 diamond-shaped filter (911) can be applied for a luma component (e.g., a luma block, a luma CB). Other suitable shape(s) and size(s) can be used in the ALF. For example, a 9×9 diamond-shaped filter can be used.

[0113] Filter coefficients at locations indicated by the values (e.g., C0-C6 in (910) or C0-C12 in (920)) can be non-zero. Further, when the ALF includes a clipping function, clipping values at the locations can be non-zero.

[0114] For block classification of a luma component, a 4×4 block (or luma block, luma CB) can be categorized or classified as one of multiple (e.g., 25) classes. A classification index C can be derived based on a directionality parameter D and a quantized value \hat{A} of an activity value A using Eq. (1).

$$C = 5D + \hat{A} \quad \text{Eq. (1)}$$

To calculate the directionality parameter D and the quantized value \hat{A} , gradients g_v , g_h , g_{d1} , and g_{d2} of a vertical, a horizontal, and two diagonal directions (e.g., d1 and d2), respectively, can be calculated using 1-D Laplacian as follows.

$$g_v = \sum_{k=i-2}^{i+3} \sum_{l=j-2}^{j+3} V_{k,l}, \quad V_{k,l} = |2R(k,l) - R(k,l-1) - R(k,l+1)| \quad \text{Eq. (2)}$$

$$g_h = \sum_{k=i-2}^{i+3} \sum_{l=j-2}^{j+3} H_{k,l}, \quad H_{k,l} = |2R(k,l) - R(k-1,l) - R(k+1,l)| \quad \text{Eq. (3)}$$

$$g_{d1} = \sum_{k=i-2}^{i+3} \sum_{l=j-3}^{j+3} D1_{k,l}, \quad D1_{k,l} = |2R(k,l) - R(k-1,l-1) - R(k+1,l+1)| \quad \text{Eq. (4)}$$

$$g_{d2} = \sum_{k=i-2}^{i+3} \sum_{l=j-2}^{j+3} D2_{k,l}, \quad D2_{k,l} = |2R(k,l) - R(k-1,l+1) - R(k+1,l-1)| \quad \text{Eq. (5)}$$

where indices i and j refer to coordinates of an upper left sample within the 4×4 block and R(k,l) indicates a reconstructed sample at a coordinate (k,l). The directions (e.g., d1 and d2) can refer to 2 diagonal directions.

[0115] To reduce complexity of the block classification described above, a subsampled 1-D Laplacian calculation can be applied. FIGs. 10A-10D show examples of subsampled positions used for calculating the gradients g_v , g_h , g_{d1} , and g_{d2} of the vertical (FIG. 10A), the horizontal (FIG. 10B), and the two diagonal directions d1 (FIG. 10C) and d2 (FIG. 10D), respectively. The same subsampled positions can be used for gradient calculation of the different directions. In FIG. 10A, labels 'V' show the subsampled positions to calculate the vertical gradient g_v . In FIG. 10B, labels 'H' show the subsampled positions to calculate the horizontal gradient g_h . In FIG. 10C, labels 'D1' show the subsampled positions to calculate the d1 diagonal gradient g_{d1} . In FIG. 10D, labels 'D2' show the subsampled positions to calculate the d2 diagonal gradient g_{d2} .

[0116] A maximum value $g_{h,v}^{max}$ and a minimum value $g_{h,v}^{min}$ of the gradients of horizontal and vertical directions g_v and g_h can be set as:

$$g_{h,v}^{max} = \max(g_h, g_v), \quad g_{h,v}^{min} = \min(g_h, g_v) \quad \text{Eq. (6)}$$

A maximum value $g_{d1,d2}^{max}$ and a minimum value $g_{d1,d2}^{min}$ of the gradients of two diagonal directions g_{d1} and g_{d2} can be set as:

$$g_{d1,d2}^{max} = \max(g_{d1}, g_{d2}), \quad g_{d1,d2}^{min} = \min(g_{d1}, g_{d2}) \quad \text{Eq. (7)}$$

The directionality parameter D can be derived based on the above values and two thresholds t_1 and t_2 as below.

Step 1. If (1) $g_{h,v}^{max} \leq t_1 \cdot g_{h,v}^{min}$ and (2) $g_{d1,d2}^{max} \leq t_1 \cdot g_{d1,d2}^{min}$ are true, D is set to 0.

Step 2. If $g_{h,v}^{max}/g_{h,v}^{min} > g_{d1,d2}^{max}/g_{d1,d2}^{min}$, continue to Step 3; otherwise continue to Step 4.

Step 3. If $g_{h,v}^{max} > t_2 \cdot g_{h,v}^{min}$, D is set to 2; otherwise D is set to 1.

Step 4. If $g_{d1,d2}^{max} > t_2 \cdot g_{d1,d2}^{min}$, D is set to 4; otherwise D is set to 3.

[0117] The activity value A can be calculated as:

$$A = \sum_{k=i-2}^{i+3} \sum_{l=j-2}^{j+3} (V_{k,l} + H_{k,l}) \quad \text{Eq. (8)}$$

A can be further quantized to a range of 0 to 4, inclusively, and the quantized value is denoted as \hat{A} .

[0118] For chroma components in a picture, no block classification is applied, and thus a single set of ALF coefficients can be applied for each chroma component.

[0119] Geometric transformations can be applied to filter coefficients and corresponding filter clipping values (also referred to as clipping values). Before filtering a block (e.g., a 4×4 luma block), geometric transformations such as rotation or diagonal and vertical flipping can be

applied to the filter coefficients $f(k, l)$ and the corresponding filter clipping values $c(k, l)$, for example, depending on gradient values (e.g., g_v , g_h , g_{d1} , and/or g_{d2}) calculated for the block. The geometric transformations applied to the filter coefficients $f(k, l)$ and the corresponding filter clipping values $c(k, l)$ can be equivalent to applying the geometric transformations to samples in a region supported by the filter. The geometric transformations can make different blocks to which an ALF is applied more similar by aligning the respective directionality.

[0120] Three geometric transformations, including a diagonal flip, a vertical flip, and a rotation can be performed as described by Eqs. (9)-(11), respectively.

$$f_D(k,l) = f(l,k), c_D(k,l) = c(l,k), \quad \text{Eq. (9)}$$

$$f_V(k,l) = f(k,K-l-1), c_V(k,l) = c(k,K-l-1) \quad \text{Eq. (10)}$$

$$f_R(k,l) = f(K-l-1,k), c_R(k,l) = c(K-l-1,k) \quad \text{Eq. (11)}$$

where K is a size of the ALF or the filter, and $0 \leq k,l \leq K-1$ are coordinates of coefficients. For example, a location $(0,0)$ is at an upper left corner and a location $(K-1, K-1)$ is at a lower right corner of the filter f or a clipping value matrix (or clipping matrix) c . The transformations can be applied to the filter coefficients $f(k, l)$ and the clipping values $c(k, l)$ depending on the gradient values calculated for the block. An example of a relationship between the transformation and the four gradients are summarized in Table 1.

Table 1: Mapping of the gradient calculated for a block and the transformation

Gradient values	Transformation
$g_{d2} < g_{d1}$ and $g_h < g_v$	No transformation
$g_{d2} < g_{d1}$ and $g_v < g_h$	Diagonal flip
$g_{d1} < g_{d2}$ and $g_h < g_v$	Vertical flip
$g_{d1} < g_{d2}$ and $g_v < g_h$	Rotation

[0121] In some embodiments, ALF filter parameters are signaled in an Adaptation Parameter Set (APS) for a picture. In the APS, one or more sets (e.g., up to 25 sets) of luma filter coefficients and clipping value indexes can be signaled. In an example, a set of the one or more sets can include luma filter coefficients and one or more clipping value indexes. One or more sets (e.g., up to 8 sets) of chroma filter coefficients and clipping value indexes can be signaled. To reduce signaling overhead, filter coefficients of different classifications (e.g., having different classification indices) for luma components can be merged. In a slice header, indices of the APSs used for a current slice can be signaled.

[0122] In an embodiment, a clipping value index (also referred to as clipping index) can be decoded from the APS. The clipping value index can be used to determine a corresponding clipping value, for example, based on a relationship between the clipping value index and the corresponding clipping value. The relationship can be pre-defined and stored in a decoder. In an example, the relationship is described by a table, such as a luma table (e.g., used for a luma CB) of the clipping value index and the corresponding clipping value, a chroma table (e.g., used for a chroma CB) of the clipping value index and the corresponding clipping value. The clipping value can be dependent of a bit depth B . The bit depth B can refer to an internal bit depth, a bit depth of reconstructed samples in a CB to be filtered, or the like. In some examples, a table (e.g., a luma table, a chroma table) is obtained using Eq. (12).

$$\text{AlfClip} = \left\{ \text{round}\left(2^{B \frac{N-n+1}{N}}\right) \text{ for } n \in [1..N] \right\}, \quad \text{Eq. (12)}$$

where AlfClip is the clipping value, B is the bit depth (e.g., bitDepth), N (e.g., $N = 4$) is a number of allowed clipping values, and $(n-1)$ is the clipping value index (also referred to as clipping index or clipIdx). Table 2 shows an example of a table obtained using Eq. (12) with $N = 4$. The clipping index $(n-1)$ can be 0, 1, 2, and 3 in Table 2, and n can be 1, 2, 3, and 4, respectively. Table 2 can be used for luma blocks or chroma blocks.

Table 2 – AlfClip can depend on the bit depth B and clipIdx

bitDepth	clipIdx			
	0	1	2	3
8	255	64	16	4
9	511	108	23	5
10	1023	181	32	6
11	2047	304	45	7
12	4095	512	64	8
13	8191	861	91	10
14	16383	1448	128	11
15	32767	2435	181	13
16	65535	4096	256	16

[0123] In a slice header for a current slice, one or more APS indices (e.g., up to 7 APS indices) can be signaled to specify luma filter sets that can be used for the current slice. The filtering process can be controlled at one or more suitable levels, such as a picture level, a slice

level, a CTB level, and/or the like. In an embodiment, the filtering process can be further controlled at a CTB level. A flag can be signaled to indicate whether the ALF is applied to a luma CTB. The luma CTB can choose a filter set among a plurality of fixed filter sets (e.g., 16 fixed filter sets) and the filter set(s) (also referred to as signaled filter set(s)) that are signaled in the APSs. A filter set index can be signaled for the luma CTB to indicate the filter set (e.g., the filter set among the plurality of fixed filter sets and the signaled filter set(s)) to be applied. The plurality of fixed filter sets can be pre-defined and hard-coded in an encoder and a decoder, and can be referred to as pre-defined filter sets.

[0124] For a chroma component, an APS index can be signaled in the slice header to indicate the chroma filter sets to be used for the current slice. At the CTB level, a filter set index can be signaled for each chroma CTB if there is more than one chroma filter set in the APS.

[0125] The filter coefficients can be quantized with a norm equal to 128. In order to decrease the multiplication complexity, a bitstream conformance can be applied so that the coefficient value of the non-central position can be in a range of -27 to $27 - 1$, inclusive. In an example, the central position coefficient is not signaled in the bitstream and can be considered as equal to 128.

[0126] In some embodiments, the syntaxes and semantics of clipping index and clipping values are defined as follows:

$\text{alf_luma_clip_idx}[\text{sfIdx}][j]$ can be used to specify the clipping index of the clipping value to use before multiplying by the j -th coefficient of the signaled luma filter indicated by sfIdx . A requirement of bitstream conformance can include that the values of $\text{alf_luma_clip_idx}[\text{sfIdx}][j]$ with $\text{sfIdx} = 0$ to $\text{alf_luma_num_filters_signalled_minus1}$ and $j = 0$ to 11 shall be in the range of 0 to 3, inclusive.

The luma filter clipping values $\text{AlfClipL}[\text{adaptation_parameter_set_id}]$ with elements $\text{AlfClipL}[\text{adaptation_parameter_set_id}][\text{filtIdx}][j]$, with $\text{filtIdx} = 0$ to $\text{NumAlfFilters} - 1$ and $j = 0$ to 11 can be derived as specified in Table 2 depending on bitDepth set equal to BitDepthY and clipIdx set equal to $\text{alf_luma_clip_idx}[\text{alf_luma_coeff_delta_idx}[\text{filtIdx}][j]]$.

$\text{alf_chroma_clip_idx}[\text{altIdx}][j]$ can be used to specify the clipping index of the clipping value to use before multiplying by the j -th coefficient of the alternative chroma filter with index altIdx . A requirement of bitstream conformance can include that the values of

alf_chroma_clip_idx[altIdx][j] with altIdx = 0 to alf_chroma_num_alt_filters_minus1, j = 0 to 5 shall be in the range of 0 to 3, inclusive.

The chroma filter clipping values AlfClipC[adaptation_parameter_set_id][altIdx] with elements AlfClipC[adaptation_parameter_set_id][altIdx][j], with altIdx = 0 to alf_chroma_num_alt_filters_minus1, j = 0 to 5 can be derived as specified in Table 2 depending on bitDepth set equal to BitDepthC and clipIdx set equal to alf_chroma_clip_idx[altIdx][j].

[0127] In an embodiment, the filtering process can be described as below. At a decoder side, when the ALF is enabled for a CTB, a sample R(i,j) within a CU (or CB) can be filtered, resulting in a filtered sample value R'(i,j) as shown below using Eq. (13). In an example, each sample in the CU is filtered.

$$R'(i,j) = R(i,j) + \left(\left(\sum_{k \neq 0} \sum_{l \neq 0} f(k,l) \times K(R(i+k,j+l) - R(i,j), c(k,l)) + 64 \right) \gg 7 \right)$$

Eq. (13)

where f(k,l) denotes the decoded filter coefficients, K(x, y) is a clipping function, and c(k, l) denotes the decoded clipping parameters (or clipping values). The variables k and l can vary between -L/2 and L/2 where L denotes a filter length. The clipping function K(x, y) = min (y, max(-y, x)) corresponds to a clipping function Clip3 (-y, y, x). By incorporating the clipping function K(x, y), the loop filtering method (e.g., ALF) becomes a non-linear process, and can be referred to a nonlinear ALF.

[0128] In the nonlinear ALF, multiple sets of clipping values can be provided in Table 3. In an example, a luma set includes four clipping values {1024, 181, 32, 6}, and a chroma set includes 4 clipping values {1024, 161, 25, 4}. The four clipping values in the luma set can be selected by approximately equally splitting, in a logarithmic domain, a full range (e.g., 1024) of the sample values (coded on 10 bits) for a luma block. The range can be from 4 to 1024 for the chroma set.

Table 3 – Examples of clipping values

	INTRA/INTER tile group
LUMA	{ 1024, 181, 32, 6 }
CHROMA	{ 1024, 161, 25, 4 }

[0129] The selected clipping values can be coded in an “alf_data” syntax element as follows: a suitable encoding scheme (e.g., a Golomb encoding scheme) can be used to encode a

clipping index corresponding to the selected clipping value such as shown in Table 3. The encoding scheme can be the same encoding scheme used for encoding the filter set index.

[0130] In an embodiment, a virtual boundary filtering process can be used to reduce a line buffer requirement of the ALF. Accordingly, modified block classification and filtering can be employed for samples near CTU boundaries (e.g., a horizontal CTU boundary). A virtual boundary (1130) can be defined as a line by shifting a horizontal CTU boundary (1120) by “ N_{samples} ” samples, as shown in FIG. 11A, where N_{samples} can be a positive integer. In an example, N_{samples} is equal to 4 for a luma component, and N_{samples} is equal to 2 for a chroma component.

[0131] Referring to FIG. 11A, a modified block classification can be applied for a luma component. In an example, for the 1D Laplacian gradient calculation of a 4x4 block (1110) above the virtual boundary (1130), only samples above the virtual boundary (1130) are used. Similarly, referring to FIG. 11B, for a 1D Laplacian gradient calculation of a 4x4 block (1111) below a virtual boundary (1131) that is shifted from a CTU boundary (1121), only samples below the virtual boundary (1131) are used. The quantization of an activity value A can be accordingly scaled by taking into account a reduced number of samples used in the 1D Laplacian gradient calculation.

[0132] For a filtering processing, a symmetric padding operation at virtual boundaries can be used for both a luma component and a chroma component. FIGs. 12A-12F illustrate examples of such modified ALF filtering for a luma component at virtual boundaries. When a sample being filtered is located below a virtual boundary, neighboring samples that are located above the virtual boundary can be padded. When a sample being filtered is located above a virtual boundary, neighboring samples that are located below the virtual boundary can be padded. Referring to FIG. 12A, a neighboring sample C0 can be padded with a sample C2 that is located below a virtual boundary (1210). Referring to FIG. 12B, a neighboring sample C0 can be padded with a sample C2 that is located above a virtual boundary (1220). Referring to FIG. 12C, neighboring samples C1-C3 can be padded with samples C5-C7, respectively, that are located below a virtual boundary (1230). Referring to FIG. 12D, neighboring samples C1-C3 can be padded with samples C5-C7, respectively, that are located above a virtual boundary (1240). Referring to FIG. 12E, neighboring samples C4-C8 can be padded with samples C10, C11, C12, C11, and C10, respectively, that are located below a virtual boundary (1250).

Referring to FIG. 12F, neighboring samples C4-C8 can be padded with samples C10, C11, C12, C11, and C10, respectively, that are located above a virtual boundary (1260).

[0133] In some examples, the above description can be suitably adapted when sample(s) and neighboring sample(s) are located to the left (or to the right) and to the right (or to the left) of a virtual boundary.

[0134] A cross-component filtering process can apply cross-component filters, such as cross-component adaptive loop filters (CC-ALFs). The cross-component filter can use luma sample values of a luma component (e.g., a luma CB) to refine a chroma component (e.g., a chroma CB corresponding to the luma CB). In an example, the luma CB and the chroma CB are included in a CU.

[0135] FIG. 13 shows cross-component filters (e.g., CC-ALFs) used to generate chroma components according to an embodiment of the disclosure. In some examples, FIG. 13 shows filtering processes for a first chroma component (e.g., a first chroma CB), a second chroma component (e.g., a second chroma CB), and a luma component (e.g., a luma CB). The luma component can be filtered by a sample adaptive offset (SAO) filter (1310) to generate a SAO filtered luma component (1341). The SAO filtered luma component (1341) can be further filtered by an ALF luma filter (1316) to become a filtered luma CB (1361) (e.g., 'Y').

[0136] The first chroma component can be filtered by a SAO filter (1312) and an ALF chroma filter (1318) to generate a first intermediate component (1352). Further, the SAO filtered luma component (1341) can be filtered by a cross-component filter (e.g., CC-ALF) (1321) for the first chroma component to generate a second intermediate component (1342). Subsequently, a filtered first chroma component (1362) (e.g., 'Cb') can be generated based on at least one of the second intermediate component (1342) and the first intermediate component (1352). In an example, the filtered first chroma component (1362) (e.g., 'Cb') can be generated by combining the second intermediate component (1342) and the first intermediate component (1352) with an adder (1322). The cross-component adaptive loop filtering process for the first chroma component can include a step performed by the CC-ALF (1321) and a step performed by, for example, the adder (1322).

[0137] The above description can be adapted to the second chroma component. The second chroma component can be filtered by a SAO filter (1314) and the ALF chroma filter (1318) to generate a third intermediate component (1353). Further, the SAO filtered luma component (1341) can be filtered by a cross-component filter (e.g., a CC-ALF) (1331) for the

second chroma component to generate a fourth intermediate component (1343). Subsequently, a filtered second chroma component (1363) (e.g., 'Cr') can be generated based on at least one of the fourth intermediate component (1343) and the third intermediate component (1353). In an example, the filtered second chroma component (1363) (e.g., 'Cr') can be generated by combining the fourth intermediate component (1343) and the third intermediate component (1353) with an adder (1332). In an example, the cross-component adaptive loop filtering process for the second chroma component can include a step performed by the CC-ALF (1331) and a step performed by, for example, the adder (1332).

[0138] A cross-component filter (e.g., the CC-ALF (1321), the CC-ALF (1331)) can operate by applying a linear filter having any suitable filter shape to the luma component (or a luma channel) to refine each chroma component (e.g., the first chroma component, the second chroma component).

[0139] FIG. 14 shows an example of a filter (1400) according to an embodiment of the disclosure. The filter (1400) can include non-zero filter coefficients and zero filter coefficients. The filter (1400) has a diamond shape (1420) formed by filter coefficients (1410) (indicated by circles having black fill). In an example, the non-zero filter coefficients in the filter (1400) are included in the filter coefficients (1410), and filter coefficients not included in the filter coefficients (1410) are zero. Thus, the non-zero filter coefficients in the filter (1400) are included in the diamond shape (1420), and the filter coefficients not included in the diamond shape (1420) are zero. In an example, a number of the filter coefficients of the filter (1400) is equal to a number of the filter coefficients (1410), which is 18 in the example shown in FIG. 14.

[0140] The CC-ALF can include any suitable filter coefficients (also referred to as the CC-ALF filter coefficients). Referring back to FIG. 13, the CC-ALF (1321) and the CC-ALF (1331) can have a same filter shape, such as the diamond shape (1420) shown in FIG. 14, and a same number of filter coefficients. In an example, values of the filter coefficients in the CC-ALF (1321) are different from values of the filter coefficients in the CC-ALF (1331).

[0141] In general, filter coefficients (e.g., non-zero filter coefficients) in a CC-ALF can be transmitted, for example, in the APS. In an example, the filter coefficients can be scaled by a factor (e.g., 2^{10}) and can be rounded for a fixed point representation. Application of a CC-ALF can be controlled on a variable block size and signaled by a context-coded flag (e.g., a CC-ALF enabling flag) received for each block of samples. The context-coded flag, such as the CC-ALF enabling flag, can be signaled at any suitable level, such as a block level. The block size along

with the CC-ALF enabling flag can be received at a slice-level for each chroma component. In some examples, block sizes (in chroma samples) 16x16, 32x32, and 64x64 can be supported.

[0142] In general, a luma block can correspond to chroma block(s), such as two chroma blocks. A number of samples in each of the chroma block(s) can be less than a number of samples in the luma block. A chroma subsampling format (also referred to as a chroma subsampling format, e.g., specified by `chroma_format_idc`) can indicate a chroma horizontal subsampling factor (e.g., `SubWidthC`) and a chroma vertical subsampling factor (e.g., `SubHeightC`) between each of the chroma block(s) and the corresponding luma block. In an example, the chroma subsampling format is 4:2:0, and thus the chroma horizontal subsampling factor (e.g., `SubWidthC`) and the chroma vertical subsampling factor (e.g., `SubHeightC`) are 2, as shown in FIGs. 15A-15B. In an example, the chroma subsampling format is 4:2:2, and thus the chroma horizontal subsampling factor (e.g., `SubWidthC`) is 2, and the chroma vertical subsampling factor (e.g., `SubHeightC`) is 1. In an example, the chroma subsampling format is 4:4:4, and thus the chroma horizontal subsampling factor (e.g., `SubWidthC`) and the chroma vertical subsampling factor (e.g., `SubHeightC`) are 1. A chroma sample type (also referred to as a chroma sample position) can indicate a relative position of a chroma sample in the chroma block with respect to at least one corresponding luma sample in the luma block.

[0143] FIGs. 15A-15B show exemplary locations of chroma samples relative to luma samples according to embodiments of the disclosure. Referring to FIG. 15A, the luma samples (1501) are located in rows (1511)-(1518). The luma samples (1501) shown in FIG. 15A can represent a portion of a picture. In an example, a luma block (e.g., a luma CB) includes the luma samples (1501). The luma block can correspond to two chroma blocks having the chroma subsampling format of 4:2:0. In an example, each chroma block includes chroma samples (1503). Each chroma sample (e.g., the chroma sample (1503(1))) corresponds to four luma samples (e.g., the luma samples (1501(1))-(1501(4))). In an example, the four luma samples are the top-left sample (1501(1)), the top-right sample (1501(2)), the bottom-left sample (1501(3)), and the bottom-right sample (1501(4)). The chroma sample (e.g., (1503(1))) is located at a left center position that is between the top-left sample (1501(1)) and the bottom-left sample (1501(3)), and a chroma sample type of the chroma block having the chroma samples (1503) can be referred to as a chroma sample type 0. The chroma sample type 0 indicates a relative position 0 corresponding to the left center position in the middle of the top-left sample (1501(1)) and the

bottom-left sample (1501(3)). The four luma samples (e.g., (1501(1))-(1501(4))) can be referred to as neighboring luma samples of the chroma sample (1503)(1).

[0144] In an example, each chroma block includes chroma samples (1504). The above description with reference to the chroma samples (1503) can be adapted to the chroma samples (1504), and thus detailed descriptions can be omitted for purposes of brevity. Each of the chroma samples (1504) can be located at a center position of four corresponding luma samples, and a chroma sample type of the chroma block having the chroma samples (1504) can be referred to as a chroma sample type 1. The chroma sample type 1 indicates a relative position 1 corresponding to the center position of the four luma samples (e.g., (1501(1))-(1501(4))). For example, one of the chroma samples (1504) can be located at a center portion of the luma samples (1501(1))-(1501(4)).

[0145] In an example, each chroma block includes chroma samples (1505). Each of the chroma samples (1505) can be located at a top left position that is co-located with the top-left sample of the four corresponding luma samples (1501), and a chroma sample type of the chroma block having the chroma samples (1505) can be referred to as a chroma sample type 2. Accordingly, each of the chroma samples (1505) is co-located with the top left sample of the four luma samples (1501) corresponding to the respective chroma sample. The chroma sample type 2 indicates a relative position 2 corresponding to the top left position of the four luma samples (1501). For example, one of the chroma samples (1505) can be located at a top left position of the luma samples (1501(1))-(1501(4)).

[0146] In an example, each chroma block includes chroma samples (1506). Each of the chroma samples (1506) can be located at a top center position between a corresponding top-left sample and a corresponding top-right sample, and a chroma sample type of the chroma block having the chroma samples (1506) can be referred to as a chroma sample type 3. The chroma sample type 3 indicates a relative position 3 corresponding to the top center position between the top-left sample (and the top-right sample). For example, one of the chroma samples (1506) can be located at a top center position of the luma samples (1501(1))-(1501(4)).

[0147] In an example, each chroma block includes chroma samples (1507). Each of the chroma samples (1507) can be located at a bottom left position that is co-located with the bottom-left sample of the four corresponding luma samples (1501), and a chroma sample type of the chroma block having the chroma samples (1507) can be referred to as a chroma sample type 4. Accordingly, each of the chroma samples (1507) is co-located with the bottom left sample of

the four luma samples (1501) corresponding to the respective chroma sample. The chroma sample type 4 indicates a relative position 4 corresponding to the bottom left position of the four luma samples (1501). For example, one of the chroma samples (1507) can be located at a bottom left position of the luma samples (1501(1))-(1501(4)).

[0148] In an example, each chroma block includes chroma samples (1508). Each of the chroma samples (1508) is located at a bottom center position between the bottom -left sample and the bottom -right sample, and a chroma sample type of the chroma block having the chroma samples (1508) can be referred to as a chroma sample type 5. The chroma sample type 5 indicates a relative position 5 corresponding to the bottom center position between the bottom -left sample and the bottom -right sample of the four luma samples (1501). For example, one of the chroma samples (1508) can be located between the bottom-left sample and the bottom-right sample of the luma samples (1501(1))-(1501(4)).

[0149] In general, any suitable chroma sample type can be used for a chroma subsampling format. The chroma sample types 0-5 are exemplary chroma sample types described with the chroma subsampling format 4:2:0. Additional chroma sample types may be used for the chroma subsampling format 4:2:0. Further, other chroma sample types and/or variations of the chroma sample types 0-5 can be used for other chroma subsampling formats, such as 4:2:2, 4:4:4, or the like. In an example, a chroma sample type combining the chroma samples (1505) and (1507) is used for the chroma subsampling format 4:2:2.

[0150] In an example, the luma block is considered to have alternating rows, such as the rows (1511)-(1512) that include the top two samples (e.g., (1501(1))-(1501(2))) of the four luma samples (e.g., (1501(1))-(1501(4))) and the bottom two samples (e.g., (1501(3))-(1501(4))) of the four luma samples (e.g., (1501(1))-(1501(4))), respectively. Accordingly, the rows (1511), (1513), (1515), and (1517) can be referred to as current rows (also referred to as a top field), and the rows (1512), (1514), (1516), and (1518) can be referred to as next rows (also referred to as a bottom field). The four luma samples (e.g., (1501(1))-(1501(4))) are located at the current row (e.g., (1511)) and the next row (e.g., (1512)). The relative positions 2-3 are located in the current rows, the relative positions 0-1 are located between each current row and the respective next row, and the relative positions 4-5 are located in the next rows.

[0151] The chroma samples (1503), (1504), (1505), (1506), (1507), or (1508) are located in rows (1551)-(1554) in each chroma block. Specific locations of the rows (1551)-(1554) can depend on the chroma sample type of the chroma samples. For example, for the chroma samples

(1503)-(1504) having the respective chroma sample types 0-1, the row (1551) is located between the rows (1511)-(1512). For the chroma samples (1505)-(1506) having the respective the chroma sample types 2-3, the row (1551) is co-located with the current row (1511). For the chroma samples (1507)-(1508) having the respective the chroma sample types 4-5, the row (1551) is co-located with the next row (1512). The above descriptions can be suitably adapted to the rows (1552)-(1554), and the detailed descriptions are omitted for purposes of brevity.

[0152] Any suitable scanning method can be used for displaying, storing, and/or transmitting the luma block and the corresponding chroma block(s) described above in FIG. 15A. In an example, progressive scanning is used.

[0153] An interlaced scan can be used, as shown in FIG. 15B. As described above, the chroma subsampling format is 4:2:0 (e.g., chroma_format_idc is equal to 1). In an example, a variable chroma location type (e.g., ChromaLocType) indicates the current rows (e.g., ChromaLocType is chroma_sample_loc_type_top_field) or the next rows (e.g., ChromaLocType is chroma_sample_loc_type_bottom_field). The current rows (1511), (1513), (1515), and (1517) and the next rows (1512), (1514), (1516), and (1518) can be scanned separately, for example, the current rows (1511), (1513), (1515), and (1517) can be scanned first followed by the next rows (1512), (1514), (1516), and (1518) being scanned. The current rows can include the luma samples (1501) while the next rows can include the luma samples (1502).

[0154] Similarly, the corresponding chroma block can be interlaced scanned. The rows (1551) and (1553) including the chroma samples (1503), (1504), (1505), (1506), (1507), or (1508) with no fill can be referred to as current rows (or current chroma rows), and the rows (1552) and (1554) including the chroma samples (1503), (1504), (1505), (1506), (1507), or (1508) with gray fill can be referred to as next rows (or next chroma rows). In an example, during the interlaced scan, the rows (1551) and (1553) are scanned first followed by scanning the rows (1552) and (1554).

[0155] The diamond filter shape (1420) in FIG. 14 is designed for the chroma subsampling format of 4:2:0 and the chroma sample type 0 (e.g., a chroma row is between two luma rows), which may not be efficient for other chroma sample types (e.g., the chroma sample types 1-5) and other chroma subsampling formats (e.g., 4:2:2 and 4:4:4).

[0156] Coded information of a chroma block or a chroma CB (e.g., the first chroma CB or the second chroma CB in FIG. 13) can be decoded from a coded video bitstream. The coded information can indicate that a cross-component filter is applied to the chroma CB. The coded

information can further include a chroma subsampling format and a chroma sample type. As described above, the chroma subsampling format can indicate a chroma horizontal subsampling factor and a chroma vertical subsampling factor between the chroma CB and a corresponding luma CB (e.g., the luma CB in FIG. 13). The chroma sample type can indicate a relative position of a chroma sample with respect to at least one corresponding luma sample in the luma CB. In an example, the chroma sample type is signaled in the coded video bitstream. The chroma sample type can be signaled at any suitable level, such as in a sequence parameter set (SPS).

[0157] According to aspects of the disclosure, a filter shape of a cross-component filter (e.g., the CC-ALF (1321)) in the cross-component filtering process can be determined based on at least one of the chroma subsampling format and the chroma sample type. Further, a first intermediate CB (e.g., the intermediate component (1342)) can be generated by applying the cross-component filter having the determined filter shape to the corresponding luma CB (e.g., the SAO filtered luma component (1341)). A second intermediate CB (e.g., the intermediate component (1352)) can be generated by applying a loop filter (e.g., the ALF (1318)) to the chroma CB (e.g., the SAO filtered first chroma CB). A filtered chroma CB (e.g., the filtered first chroma component (1362) (e.g., 'Cb') in FIG. 13) can be determined based on the first intermediate CB and the second intermediate CB. As described above, the cross-component filter can be a CC-ALF and the loop filter can be an ALF.

[0158] The chroma sample type of the chroma block can be indicated in the coded bitstream when the CC-ALF is used. The filter shape of the CC-ALF can be dependent on the chroma subsampling format (e.g., `chroma_format_idc`) of the chroma block, the chroma sample type, and/or the like.

[0159] FIG. 16 shows exemplary cross-component filters (e.g., CC-ALFs) (1601)-(1603) having respective filter shapes (1621)-(1623) according to embodiments of the disclosure. Referring to FIGs. 14 and 16, the filter shapes (1420) and (1621)-(1623) can be used for the CC-ALF based on the chroma sample type of the chroma block, for example, when the chroma subsampling format of 4:2:0.

[0160] According to aspects of the disclosure, the chroma sample type can be one of the six chroma sample types 0-5 indicating the six relative positions 0-5, respectively. The six relative positions 0-5 can correspond to the left-center position, the center position, the top-left position, the top-center position, the bottom-left position, and the bottom-center position of the

four luma samples (e.g., (1501(1))-(1501(4))), respectively, such as shown in FIG. 15A. The filter shape of the cross-component filter can be determined based on the chroma sample type.

[0161] When the chroma sample type of the chroma block is the chroma sample type 0, the filter (1400) having the filter shape (1420) in FIG. 14 can be used in the cross-component filter (e.g., the CC-ALF).

[0162] In an example, when the chroma sample type of the chroma block is the chroma sample type 1, a square filter shape (e.g., a 4×4 square filter shape, a 2×2 square filter shape) can be used in the cross-component filter (e.g., the CC-ALF). A chroma sample (e.g., (1504(1)) in FIG. 15A) being cross-component filtered can be located in a center of the square filter shape as the chroma sample (e.g., (1504(1))) is located in the center of four corresponding luma samples (e.g., (1501(1))-(1501(4))).

[0163] In an example, when the chroma sample type of the chroma block is the chroma sample type 2, a diamond filter shape (e.g., the 5×5 diamond filter shape (1621) of the filter (1601) or the 3×3 diamond filter shape (1622) of the filter (1602)) can be used in the CC-ALF.

[0164] In an example, when the chroma sample type of the chroma block is the chroma sample type 3, the diamond filter shape (1623) of the filter (1603) can be used in the CC-ALF. Referring to FIGs. 14 and 16, the diamond filter shape (1623) is a geometric transformation (e.g., a 90° rotation) of the filter shape (1420).

[0165] In an example, when the chroma sample type of the chroma block is the chroma sample type 4, a filter shape used in the CC-ALF can be identical or similar to that (e.g., the diamond filter shape (1621) or (1622)) used for the chroma sample type 2. Thus, the filter shape for the chroma sample type 4 can be a diamond filter shape, such as the diamond filter shape (1621) or (1622) shifted vertically.

[0166] In an example, when the chroma sample type of the chroma block is the chroma sample type 5, a filter shape used in the CC-ALF can be identical or similar to that (e.g., the diamond filter shape (1623)) used for the chroma sample type 3. Thus, the filter shape for the chroma sample type 5 can be a diamond filter shape, such as the diamond filter shape (1623) shifted vertically.

[0167] In an embodiment, the number of filter coefficients is signaled in the coded video bitstream, such as in an APS. Referring to FIGs. 14 and 16, filter coefficients (1611) can form the diamond shape (1621), and other filter coefficients not included in, or otherwise excluded from, the filter coefficients (1611) are zero. Accordingly, the number of filter coefficients for the

filter (1601) can refer to the number of filter coefficients in the filter shape (1621), and thus can be equal to the number (e.g., 13) of filter coefficients (1611). Similarly, the number of filter coefficients of the filter (1602) can refer to the number of filter coefficients in the filter shape (1622), and thus can be equal to the number (e.g., 5) of filter coefficients (1612). The number of filter coefficients of the filter (1603) can refer to the number of filter coefficients in the filter shape (1623), and thus can be equal to the number (e.g., 18) of filter coefficients (1613). Similarly, the number of filter coefficients of the filter (1400) can be 18.

[0168] Different filter shapes can have different numbers of coefficients. Thus, in some examples, the filter shape can be determined based on the number of filter coefficients. For example, when the number of filter coefficients is 16, the filter shape can be determined to be a 4×4 square filter shape.

[0169] According to aspects of the disclosure, the number of filter coefficients of the cross-component filter can be signaled in the coded video bitstream. Further, the filter shape of the cross-component filter can be determined based on the number of filter coefficients and the at least one of the chroma subsampling format and the chroma sample type.

[0170] In an embodiment, a cross-component linear model (CCLM) flag can indicate the chroma sample type. Accordingly, the filter shape of the CC-ALF may be dependent on the CCLM flag. In an example, the chroma sample type indicated by the CCLM flag is the chroma sample type 0 or 2, and thus the filter shape can be the filter shape (1420) or the diamond filter shape (e.g., the 5×5 diamond filter shape (1621) or the 3×3 diamond filter shape (1622)).

[0171] In an embodiment, the CCLM flag (e.g., a `sps_cclm_colocated_chroma_flag`) is signaled in the coded video bitstream, for example, in the SPS. In an example, the CCLM flag (e.g., the `sps_cclm_colocated_chroma_flag`) indicates whether a top-left down-sampled luma sample in a CCLM intra prediction is collocated with a top-left luma sample. As described above, the chroma sample type indicated by the CCLM flag can be the chroma sample type 0 or 2. The filter shape of the CC-ALF may be dependent on the `sps_cclm_colocated_chroma_flag` or similar information (e.g., information indicating whether the top-left down-sampled luma sample in the CCLM intra prediction is collocated with the top-left luma sample) for CCLM signaled in the SPS.

[0172] In some examples, the cross-component filter (e.g., the CC-ALF) includes a large number (e.g., 18) of multiplications per chroma sample (e.g., a Cb chroma sample or a Cr chroma sample), thus having a high cost, for example, in calculation complexity. The number of

multiplications is based on a number of filter coefficients (e.g., 18 filter coefficients in the filters (1400) and (1603), 13 filter coefficients in the filter (1601), and 5 filter coefficients in the filter (1602)) in the CC-ALF. For example, the number of multiplications is equal to the number of filter coefficients in the CC-ALF. According to aspects of the disclosure, a number of bits representing the CC-ALF filter coefficients of the CC-ALF can be constrained to be less than or equal to K bits. K can be a positive integer, such as 8. Thus, the CC-ALF filter coefficients can be included in a range of $[-2^{K-1}$ to $2^{K-1}-1]$. The range of the CC-ALF filter coefficients in the CC-ALF can be constrained to be less than or equal to K bits such that simpler multipliers (e.g., having less bits) for the CC-ALF can be used.

[0173] In an embodiment, the range of the CC-ALF filter coefficients is constrained between -2^4 to 2^4-1 where K is 5 bits. Alternatively, the range of the CC-ALF filter coefficients is constrained between -2^5 to 2^5-1 where K is 6 bits.

[0174] In an example, a number of different values of the CC-ALF filter coefficients is constrained to be a certain number, such as K bits. A lookup table can be used when applying the CC-ALF.

[0175] The CC-ALF filter coefficients of the CC-ALF can be coded and signaled using fixed-length coding. For example, if the CC-ALF filter coefficients are constrained to be K bits, K bits fixed-length coding can be used to signal the CC-ALF filter coefficients. When K is relatively small, such as 8 bits, the fixed-length coding can be more efficient than other methods, such as variable-length coding.

[0176] Referring back to FIG. 13, according to aspects of the disclosure, luma sample values (e.g., (1341)) of the luma CB can be shifted to have a dynamic range of L bits if the dynamic range (or a luma bit-depth) of the luma sample values (e.g., (1341)) is larger than L bits. L can be a positive integer, such as 8. Subsequently, the intermediate component (e.g., (1342) or (1343)) can be generated by applying the CC-ALF (e.g., (1321) or (1331)) to the shifted luma sample values.

[0177] Referring back to FIG. 13, the cross-component adaptive loop filtering process using the CC-ALF (e.g., (1321) or (1331)) can be modified as described below if the luma bit-depth of the luma sample values (e.g., the luma sample values of the SAO filtered luma component (1341)) is higher than L-bits. The luma sample values (e.g., (1341)) can be first shifted to an L-bit dynamic range. The shifted luma sample values can be unsigned L-bits. In an example, L is 8. Subsequently, the shifted luma sample values can be used as an input to the

CC-ALF (e.g., (1321) or (1331)). Thus, the shifted luma sample values and the CC-ALF filter coefficients can be multiplied. As described above, the CC-ALF filter coefficients can be constrained to signed values of less than or equal to K bits (e.g., 8 bits or $[-2^{K-1}$ to $2^{K-1}-1$]), a multiplier of unsigned L-bits by signed K-bits may be used. In an example, K and L are 8 bits, and a relatively simple and efficient multiplier (e.g., a multiplier based on single instruction, multiple data (SIMD) instructions) of unsigned 8-bits by signed 8-bits may be used to improve the filtering efficiency.

[0178] Referring to FIG. 13, according to aspects of the disclosure, a down-sampled luma CB can be generated by applying a down-sampling filter to the luma CB. Thus, a chroma horizontal subsampling factor and a chroma vertical subsampling factor between the first chroma CB (or the second chroma CB) and the down-sampled luma CB is one. The down-sampling filter can be applied at any suitable step before the down-sampled luma CB is used as an input to the CC-ALF (e.g., (1321)). In an example, the down-sampling filter is applied between the SAO filter (1310) and the CC-ALF (e.g., (1321)), and thus the SAO filtered luma component (1341) is down-sampled first and then the down-sampled and SAO filtered luma component is sent to the CC-ALF (1321).

[0179] As described above, the filter shape of the CC-ALF can be determined based on the chroma subsampling format and/or the chroma sample type, and thus in some examples, different filter shapes can be used for different chroma sample types. Alternatively, the CC-ALF (e.g., (1321)) can use a unified filter shape when the input to the CC-ALF is the down-sampled luma CB as the down-sampled luma samples are aligned with the chroma samples with the chroma horizontal subsampling factor and the chroma vertical subsampling factor being one. The unified filter shape can be independent of the chroma subsampling format and the chroma sample type of the chroma CB. Accordingly, an intermediate CB (e.g., the intermediate component (1342)) can be generated by applying the CC-ALF having the unified filter shape to the down-sampled luma CB.

[0180] Referring to FIG. 13, in an example, for the chroma subsampling format that is the YUV (e.g., YCbCr or YCgCo) format, a down-sampling filter is applied to the luma samples in the luma CB to derive down-sampled luma samples whose positions are aligned with the chroma samples in the first chroma CB, then a unified filtering shape can be applied in the CC-ALF (e.g., (1321)) to cross-filter the down-sampled luma samples to generate the intermediate component (1342).

[0181] The down-sampling filter can be any suitable filter. In an example, the down-sampling filter corresponds to a filter applied to co-located luma samples in a CCLM mode. Thus, the luma samples are down-sampled using the same down-sampling filter that is applied to the co-located luma samples in the CCLM mode.

[0182] In an example, the down-sampling filter is a $\{1,2,1;1,2,1\}/8$ filter and the chroma subsampling format is 4:2:0. Thus, for the chroma 4:2:0 format, the luma samples are down-sampled by applying the $\{1,2,1;1,2,1\}/8$ filter.

[0183] The filter shape (or the unified filtering shape) of the cross-component filter (e.g., the CC-ALF) can have any suitable shape. In an example, the filter shape of the cross-component filter (e.g., the CC-ALF) is one of a 7×7 diamond shape, a 7×7 square shape, a 5×5 diamond shape, a 5×5 square shape, a 3×3 diamond shape, and a 3×3 square shape.

[0184] FIG. 17 shows a flow chart outlining a process (1700) according to an embodiment of the disclosure. The process (1700) can be used to reconstruct a block (e.g., a CB) in a picture of a coded video sequence. The process (1700) can be used in the reconstruction of the block so to generate a prediction block for the block under reconstruction. The term block may be interpreted as a prediction block, a CB, a CU, or the like. In various embodiments, the process (1700) are executed by processing circuitry, such as the processing circuitry in the terminal devices (310), (320), (330) and (340), the processing circuitry that performs functions of the video encoder (403), the processing circuitry that performs functions of the video decoder (410), the processing circuitry that performs functions of the video decoder (510), the processing circuitry that performs functions of the video encoder (603), and the like. In some embodiments, the process (1700) is implemented in software instructions, thus when the processing circuitry executes the software instructions, the processing circuitry performs the process (1700). The process starts at (S1701) and proceeds to (S1710). In an example, the block is a chroma block, such as a chroma CB, corresponding to a luma CB. In an example, the chroma block and the corresponding luma CB is in a CU.

[0185] At (S1710), coded information of the chroma CB can be decoded from a coded video bitstream. The coded information can indicate that a cross-component filter is applied to the chroma CB and can further indicate a chroma subsampling format and a chroma sample type. The chroma subsampling format can indicate a chroma horizontal subsampling factor and a chroma vertical subsampling factor between the chroma CB and the corresponding luma CB, as described above. The chroma subsampling format can be any suitable format, such as 4:2:0,

4:2:2, 4:4:4, or the like. The chroma sample type can indicate a relative position of a chroma sample with respect to at least one corresponding luma sample in the luma CB, as described above. In an example, for the chroma subsampling format of 4:2:0, the chroma sample type can be one of the chroma sample types 0-5 described above with reference to FIGs. 15A-15B.

[0186] At (S1720), a filter shape of the cross-component filter can be determined based on at least one of the chroma subsampling format and the chroma sample type. In an example, referring to FIG. 13, the cross-component filter is used in a cross-component filtering process (e.g., a CC-ALF filtering process) and the cross-component filter can be the CC-ALF. The filter shape can be any suitable shape that is dependent on the chroma subsampling format and/or the chroma sample type. For the chroma subsampling format of 4:2:0, the filter shape can be one of the filter shapes (1420) and (1621)-(1623) based on the chroma sample type. The filter shape can be a variation (e.g., a geometric transformation such as a rotation or a shift) of one of the filter shapes (1420) and (1621)-(1623) based on the chroma sample type.

[0187] At (S1730), a first intermediate CB can be generated by applying a loop filter (e.g., the ALF) to the chroma CB (e.g., a SAO filtered chroma CB).

[0188] At (S1740), a second intermediate CB can be generated by applying the cross-component filter (e.g., the CC-ALF) having the determined filter shape (e.g., the filter shape (1420)) to the corresponding luma CB, for example, when the chroma subsampling format is 4:2:0 and the chroma sample type is the chroma sample 0.

[0189] At (S1750), a filtered chroma CB (e.g., the filtered first chroma component (1362)) can be determined based on the first intermediate CB (e.g., the intermediate component (1342)) and the second intermediate CB (e.g., the intermediate component (1352)). The process (1700) proceeds to (S1799), and terminates.

[0190] The process (1700) can be suitably adapted. Step(s) in the process (1700) can be modified and/or omitted. Additional step(s) can be added. Any suitable order of implementation can be used.

[0191] Embodiments in the disclosure may be used separately or combined in any order. Further, each of the methods (or embodiments), an encoder, and a decoder may be implemented by processing circuitry (e.g., one or more processors or one or more integrated circuits). In one example, the one or more processors execute a program that is stored in a non-transitory computer-readable medium.

[0192] The techniques described above, can be implemented as computer software using computer-readable instructions and physically stored in one or more computer-readable media. For example, FIG. 18 shows a computer system (1800) suitable for implementing certain embodiments of the disclosed subject matter.

[0193] The computer software can be coded using any suitable machine code or computer language, that may be subject to assembly, compilation, linking, or like mechanisms to create code comprising instructions that can be executed directly, or through interpretation, micro-code execution, and the like, by one or more computer central processing units (CPUs), Graphics Processing Units (GPUs), and the like.

[0194] The instructions can be executed on various types of computers or components thereof, including, for example, personal computers, tablet computers, servers, smartphones, gaming devices, internet of things devices, and the like.

[0195] The components shown in FIG. 18 for computer system (1800) are exemplary in nature and are not intended to suggest any limitation as to the scope of use or functionality of the computer software implementing embodiments of the present disclosure. Neither should the configuration of components be interpreted as having any dependency or requirement relating to any one or combination of components illustrated in the exemplary embodiment of a computer system (1800).

[0196] Computer system (1800) may include certain human interface input devices. Such a human interface input device may be responsive to input by one or more human users through, for example, tactile input (such as: keystrokes, swipes, data glove movements), audio input (such as: voice, clapping), visual input (such as: gestures), olfactory input (not depicted). The human interface devices can also be used to capture certain media not necessarily directly related to conscious input by a human, such as audio (such as: speech, music, ambient sound), images (such as: scanned images, photographic images obtain from a still image camera), video (such as two-dimensional video, three-dimensional video including stereoscopic video).

[0197] Input human interface devices may include one or more of (only one of each depicted): keyboard (1801), mouse (1802), trackpad (1803), touch screen (1810), data-glove (not shown), joystick (1805), microphone (1806), scanner (1807), camera (1808).

[0198] Computer system (1800) may also include certain human interface output devices. Such human interface output devices may be stimulating the senses of one or more human users through, for example, tactile output, sound, light, and smell/taste. Such human interface output

devices may include tactile output devices (for example tactile feedback by the touch-screen (1810), data-glove (not shown), or joystick (1805), but there can also be tactile feedback devices that do not serve as input devices), audio output devices (such as: speakers (1809), headphones (not depicted)), visual output devices (such as screens (1810) to include CRT screens, LCD screens, plasma screens, OLED screens, each with or without touch-screen input capability, each with or without tactile feedback capability—some of which may be capable to output two dimensional visual output or more than three dimensional output through means such as stereographic output; virtual-reality glasses (not depicted), holographic displays and smoke tanks (not depicted)), and printers (not depicted).

[0199] Computer system (1800) can also include human accessible storage devices and their associated media such as optical media including CD/DVD ROM/RW (1820) with CD/DVD or the like media (1821), thumb-drive (1822), removable hard drive or solid state drive (1823), legacy magnetic media such as tape and floppy disc (not depicted), specialized ROM/ASIC/PLD based devices such as security dongles (not depicted), and the like.

[0200] Those skilled in the art should also understand that term “computer readable media” as used in connection with the presently disclosed subject matter does not encompass transmission media, carrier waves, or other transitory signals.

[0201] Computer system (1800) can also include an interface (1854) to one or more communication networks (1855). Networks can for example be wireless, wireline, optical. Networks can further be local, wide-area, metropolitan, vehicular and industrial, real-time, delay-tolerant, and so on. Examples of networks include local area networks such as Ethernet, wireless LANs, cellular networks to include GSM, 3G, 4G, 5G, LTE and the like, TV wireline or wireless wide area digital networks to include cable TV, satellite TV, and terrestrial broadcast TV, vehicular and industrial to include CANBus, and so forth. Certain networks commonly require external network interface adapters that attached to certain general purpose data ports or peripheral buses (1849) (such as, for example USB ports of the computer system (1800)); others are commonly integrated into the core of the computer system (1800) by attachment to a system bus as described below (for example Ethernet interface into a PC computer system or cellular network interface into a smartphone computer system). Using any of these networks, computer system (1800) can communicate with other entities. Such communication can be uni-directional, receive only (for example, broadcast TV), uni-directional send-only (for example CANbus to certain CANbus devices), or bi-directional, for example to other computer systems using local or

wide area digital networks. Certain protocols and protocol stacks can be used on each of those networks and network interfaces as described above.

[0202] Aforementioned human interface devices, human-accessible storage devices, and network interfaces can be attached to a core (1840) of the computer system (1800).

[0203] The core (1840) can include one or more Central Processing Units (CPU) (1841), Graphics Processing Units (GPU) (1842), specialized programmable processing units in the form of Field Programmable Gate Areas (FPGA) (1843), hardware accelerators for certain tasks (1844), graphics adapter (1850), and so forth. These devices, along with Read-only memory (ROM) (1845), Random-access memory (1846), internal mass storage such as internal non-user accessible hard drives, SSDs, and the like (1847), may be connected through a system bus (1848). In some computer systems, the system bus (1848) can be accessible in the form of one or more physical plugs to enable extensions by additional CPUs, GPU, and the like. The peripheral devices can be attached either directly to the core's system bus (1848), or through a peripheral bus (1849). In an example, a display (1810) can be connected to the graphics adapter (1850). Architectures for a peripheral bus include PCI, USB, and the like.

[0204] CPUs (1841), GPUs (1842), FPGAs (1843), and accelerators (1844) can execute certain instructions that, in combination, can make up the aforementioned computer code. That computer code can be stored in ROM (1845) or RAM (1846). Transitional data can be also be stored in RAM (1846), whereas permanent data can be stored for example, in the internal mass storage (1847). Fast storage and retrieve to any of the memory devices can be enabled through the use of cache memory, that can be closely associated with one or more CPU (1841), GPU (1842), mass storage (1847), ROM (1845), RAM (1846), and the like.

[0205] The computer readable media can have computer code thereon for performing various computer-implemented operations. The media and computer code can be those specially designed and constructed for the purposes of the present disclosure, or they can be of the kind well known and available to those having skill in the computer software arts.

[0206] As an example and not by way of limitation, the computer system having architecture (1800), and specifically the core (1840) can provide functionality as a result of processor(s) (including CPUs, GPUs, FPGA, accelerators, and the like) executing software embodied in one or more tangible, computer-readable media. Such computer-readable media can be media associated with user-accessible mass storage as introduced above, as well as certain storage of the core (1840) that are of non-transitory nature, such as core-internal mass storage

(1847) or ROM (1845). The software implementing various embodiments of the present disclosure can be stored in such devices and executed by core (1840). A computer-readable medium can include one or more memory devices or chips, according to particular needs. The software can cause the core (1840) and specifically the processors therein (including CPU, GPU, FPGA, and the like) to execute particular processes or particular parts of particular processes described herein, including defining data structures stored in RAM (1846) and modifying such data structures according to the processes defined by the software. In addition or as an alternative, the computer system can provide functionality as a result of logic hardwired or otherwise embodied in a circuit (for example: accelerator (1844)), which can operate in place of or together with software to execute particular processes or particular parts of particular processes described herein. Reference to software can encompass logic, and vice versa, where appropriate. Reference to a computer-readable media can encompass a circuit (such as an integrated circuit (IC)) storing software for execution, a circuit embodying logic for execution, or both, where appropriate. The present disclosure encompasses any suitable combination of hardware and software.

Appendix A: Acronyms

JEM: joint exploration model

VVC: versatile video coding

BMS: benchmark set

MV: Motion Vector

HEVC: High Efficiency Video Coding

MPM: most probable mode

WAIP: Wide-Angle Intra Prediction

SEI: Supplementary Enhancement Information

VUI: Video Usability Information

GOPs: Groups of Pictures

TUs: Transform Units,

PU: Prediction Units

CTUs: Coding Tree Units

CTBs: Coding Tree Blocks

PBs: Prediction Blocks

HRD: Hypothetical Reference Decoder

SDR: standard dynamic range
SNR: Signal Noise Ratio
CPUs: Central Processing Units
GPUs: Graphics Processing Units
CRT: Cathode Ray Tube
LCD: Liquid-Crystal Display
OLED: Organic Light-Emitting Diode
CD: Compact Disc
DVD: Digital Video Disc
ROM: Read-Only Memory
RAM: Random Access Memory
ASIC: Application-Specific Integrated Circuit
PLD: Programmable Logic Device
LAN: Local Area Network
GSM: Global System for Mobile communications
LTE: Long-Term Evolution
CANBus: Controller Area Network Bus
USB: Universal Serial Bus
PCI: Peripheral Component Interconnect
FPGA: Field Programmable Gate Areas
SSD: solid-state drive
IC: Integrated Circuit
CU: Coding Unit
PDPC: Position Dependent Prediction Combination
ISP: Intra Sub-Partitions
SPS: Sequence Parameter Setting

[0207] While this disclosure has described several exemplary embodiments, there are alterations, permutations, and various substitute equivalents, which fall within the scope of the disclosure. It will thus be appreciated that those skilled in the art will be able to devise numerous systems and methods which, although not explicitly shown or described herein, embody the principles of the disclosure and are thus within the spirit and scope thereof.

WHAT IS CLAIMED IS:

1. A method for video decoding in a decoder, comprising:
 - decoding coded information of a chroma coding block (CB) from a coded video bitstream, the coded information indicating that a cross-component filter is applied to the chroma CB, the coded information further indicating a chroma subsampling format and a chroma sample type that indicates a relative position of a chroma sample with respect to at least one luma sample in a corresponding luma CB;
 - determining a filter shape of the cross-component filter based on at least one of the chroma subsampling format and the chroma sample type;
 - generating a first intermediate CB by applying a loop filter to the chroma CB;
 - generating a second intermediate CB by applying the cross-component filter having the determined filter shape to the corresponding luma CB; and
 - determining a filtered chroma CB based on the first intermediate CB and the second intermediate CB.

2. The method of claim 1, wherein the chroma sample type is signaled in the coded video bitstream.

3. The method of claim 1, wherein
 - a number of filter coefficients of the cross-component filter is signaled in the coded video bitstream; and
 - the determining the filter shape includes determining the filter shape of the cross-component filter based on the number of filter coefficients and the at least one of the chroma subsampling format and the chroma sample type.

4. The method of claim 1, wherein
 - the chroma subsampling format is 4:2:0;
 - the at least one luma sample includes four luma samples that are a top-left sample, a top-right sample, a bottom-left sample, and a bottom-right sample;
 - the chroma sample type is one of six chroma sample types 0-5 indicating six relative positions 0-5, respectively, and the six relative positions 0-5 of the chroma sample correspond to a left-center position between the top-left and the bottom-left samples, a center position of the

four luma samples, a top left position co-located with the top-left sample, a top-center position between the top-left and the top-right samples, a bottom left position co-located with the bottom-left sample, and a bottom-center position between the bottom-left and the bottom-right samples, respectively; and

the determining the filter shape includes determining the filter shape of the cross-component filter based on the chroma sample type.

5. The method of claim 4, wherein the coded video bitstream includes a cross-component linear model (CCLM) flag indicating that the chroma sample type is 0 or 2.

6. The method of claim 1, wherein the cross-component filter is a cross-component adaptive loop filter (CC-ALF) and the loop filter is an adaptive loop filter (ALF).

7. The method of claim 1, wherein a range of filter coefficients of the cross-component filter is less than or equal to K bits and K is a positive integer.

8. The method of claim 7, wherein the filter coefficients of the cross-component filter are coded using fixed-length coding.

9. The method of claim 7, further comprising:
shifting luma sample values of the corresponding luma CB to have a dynamic range of 8 bits based on the dynamic range of the luma sample values being larger than 8 bits, K being 8 bits, wherein

the generating the second intermediate CB includes applying the cross-component filter having the determined filter shape to the shifted luma sample values.

10. A method for video decoding in a decoder, comprising:
decoding coded information of a chroma coding block (CB) from a coded video bitstream, the coded information indicating that a cross-component filter is applied to the chroma CB based on a corresponding luma CB;

generating a down-sampled luma CB by applying a down-sampling filter to the corresponding luma CB, a chroma horizontal subsampling factor, and a chroma vertical subsampling factor between the chroma CB and the down-sampled luma CB being one;

generating a first intermediate CB by applying a loop filter to the chroma CB;
generating a second intermediate CB by applying the cross-component filter to the down-sampled luma CB, a filter shape of the cross-component filter being independent of a chroma subsampling format and a chroma sample type of the chroma CB, the chroma sample type indicating a relative position of a chroma sample with respect to at least one luma sample in the corresponding luma CB; and
determining a filtered chroma CB based on the first intermediate CB and the second intermediate CB.

11. The method of claim 10, wherein the down-sampling filter corresponds to a filter applied to co-located luma samples in a CCLM mode.

12. The method of claim 10, wherein the down-sampling filter is a $\{1,2,1;1,2,1\}/8$ filter and the chroma subsampling format is 4:2:0.

13. The method of claim 10, wherein the filter shape of the cross-component filter is one of a 7×7 diamond shape, a 7×7 square shape, a 5×5 diamond shape, a 5×5 square shape, a 3×3 diamond shape, and a 3×3 square shape.

14. An apparatus for video decoding, comprising processing circuitry configured to:
decode coded information of a chroma coding block (CB) from a coded video bitstream, the coded information indicating that a cross-component filter is applied to the chroma CB, the coded information further indicating a chroma subsampling format and a chroma sample type that indicates a relative position of a chroma sample with respect to at least one luma sample in a corresponding luma CB;

determine a filter shape of the cross-component filter based on at least one of the chroma subsampling format and the chroma sample type;

generate a first intermediate CB by applying a loop filter to the chroma CB;

generate a second intermediate CB by applying the cross-component filter having the determined filter shape to the corresponding luma CB and

determine a filtered chroma CB based on the first intermediate CB and the second intermediate CB.

15. The apparatus of claim 14, wherein the chroma sample type is signaled in the coded video bitstream.

16. The apparatus of claim 14, wherein
a number of filter coefficients of the cross-component filter is signaled in the coded video bitstream; and

the processing circuitry is configured to determine the filter shape of the cross-component filter based on the number of filter coefficients and the at least one of the chroma subsampling format and the chroma sample type.

17. The apparatus of claim 14, wherein
the chroma subsampling format is 4:2:0;
the at least one luma sample includes four luma samples that are a top-left sample, a top-right sample, a bottom-left sample, and a bottom-right sample;

the chroma sample type is one of six chroma sample types 0-5 indicating six relative positions 0-5, respectively, and the six relative positions 0-5 of the chroma sample correspond to a left-center position between the top-left and the bottom-left samples, a center position of the four luma samples, a top left position co-located with the top-left sample, a top-center position between the top-left and the top-right samples, a bottom left position co-located with the bottom-left sample, and a bottom-center position between the bottom-left and the bottom-right samples, respectively; and

the processing circuitry is configured to determine the filter shape of the cross-component filter based on the chroma sample type.

18. The apparatus of claim 17, wherein the coded video bitstream includes a cross-component linear model (CCLM) flag indicating that the chroma sample type is 0 or 2.

19. The apparatus of claim 14, wherein the cross-component filter is a cross-component adaptive loop filter (CC-ALF) and the loop filter is an adaptive loop filter (ALF).

20. The apparatus of claim 14, wherein a range of filter coefficients of the cross-component filter is less than or equal to K bits and K is a positive integer.

	R01	R02	R03	R04	R05	R06	R07	R08	R09
R10	S11	S12	S13	S14					
R20	S21	S22	S23	S24					
R30	S31	S32	S33	S34					
R40	S41	S42	S43	S44					
R50									
R60									
R70									

104

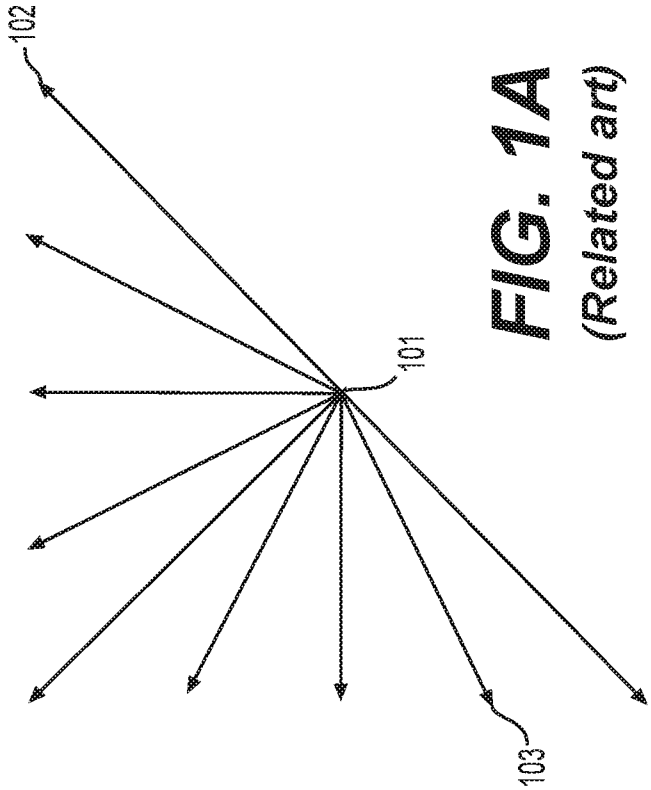
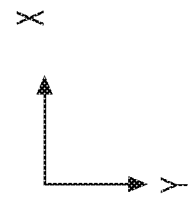

FIG. 1A
(Related art)



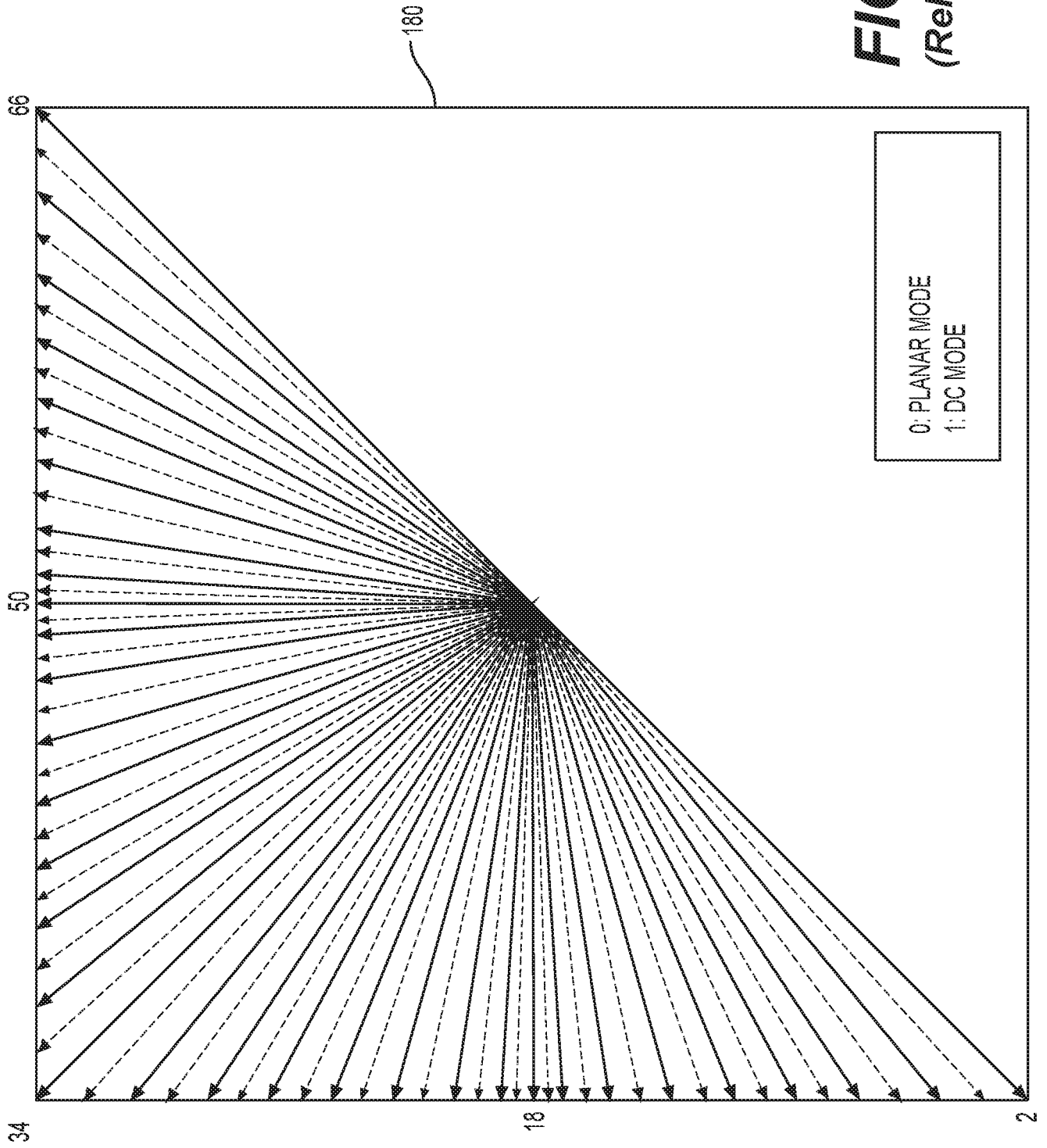

FIG. 1B
(Related art)

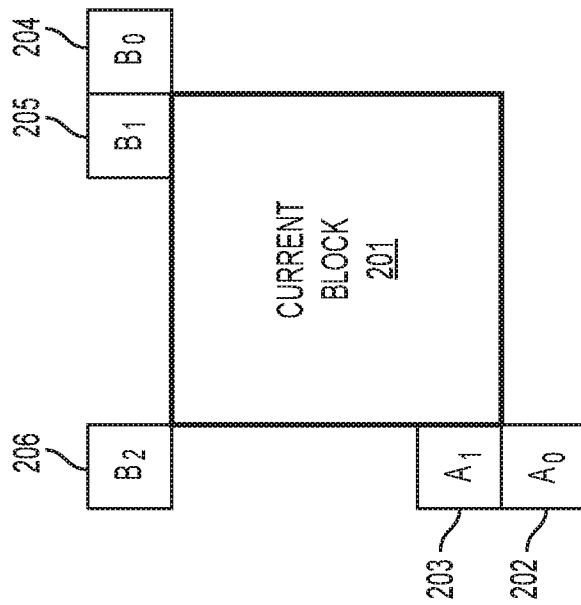

FIG. 2

(Related Art)

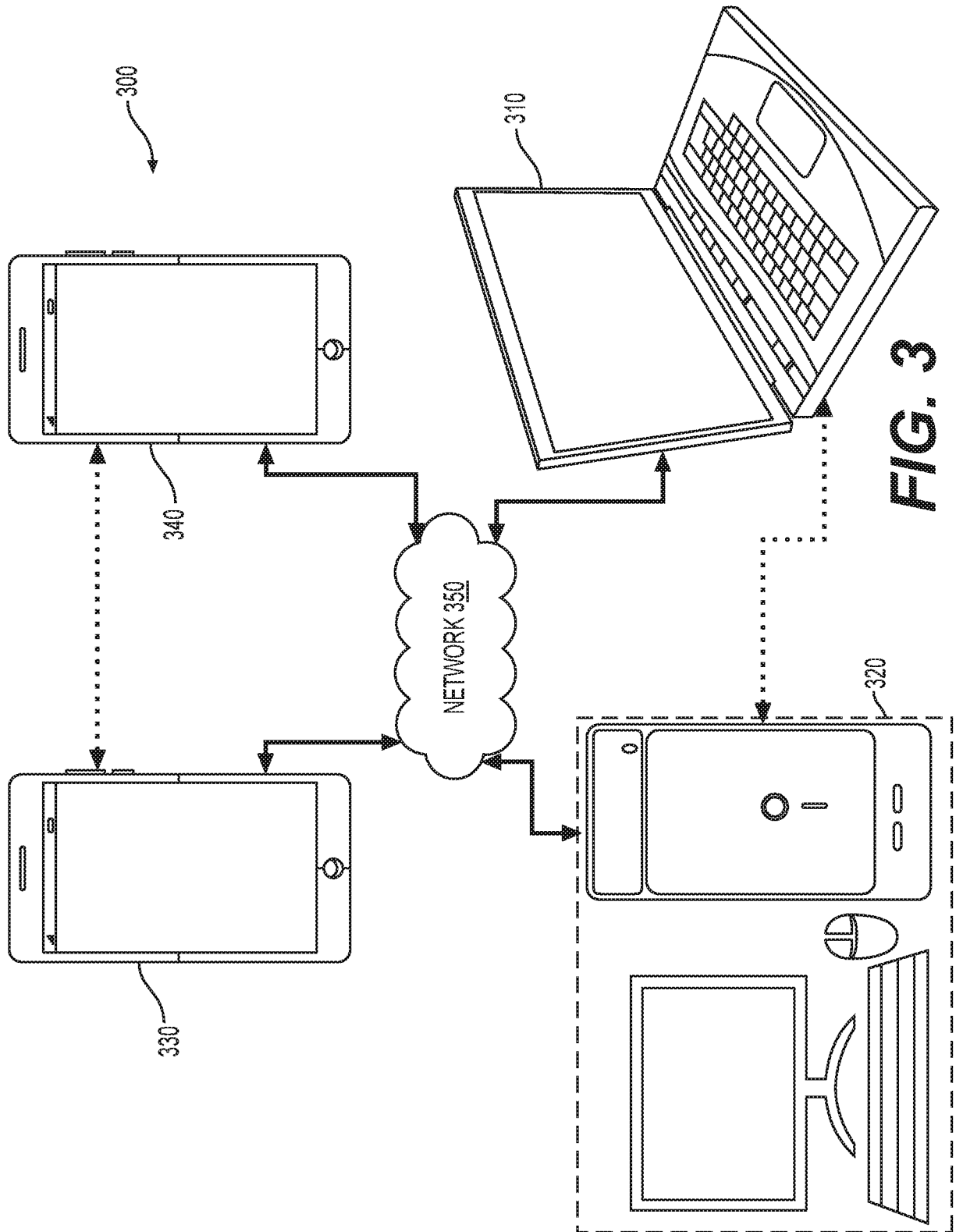

FIG. 3

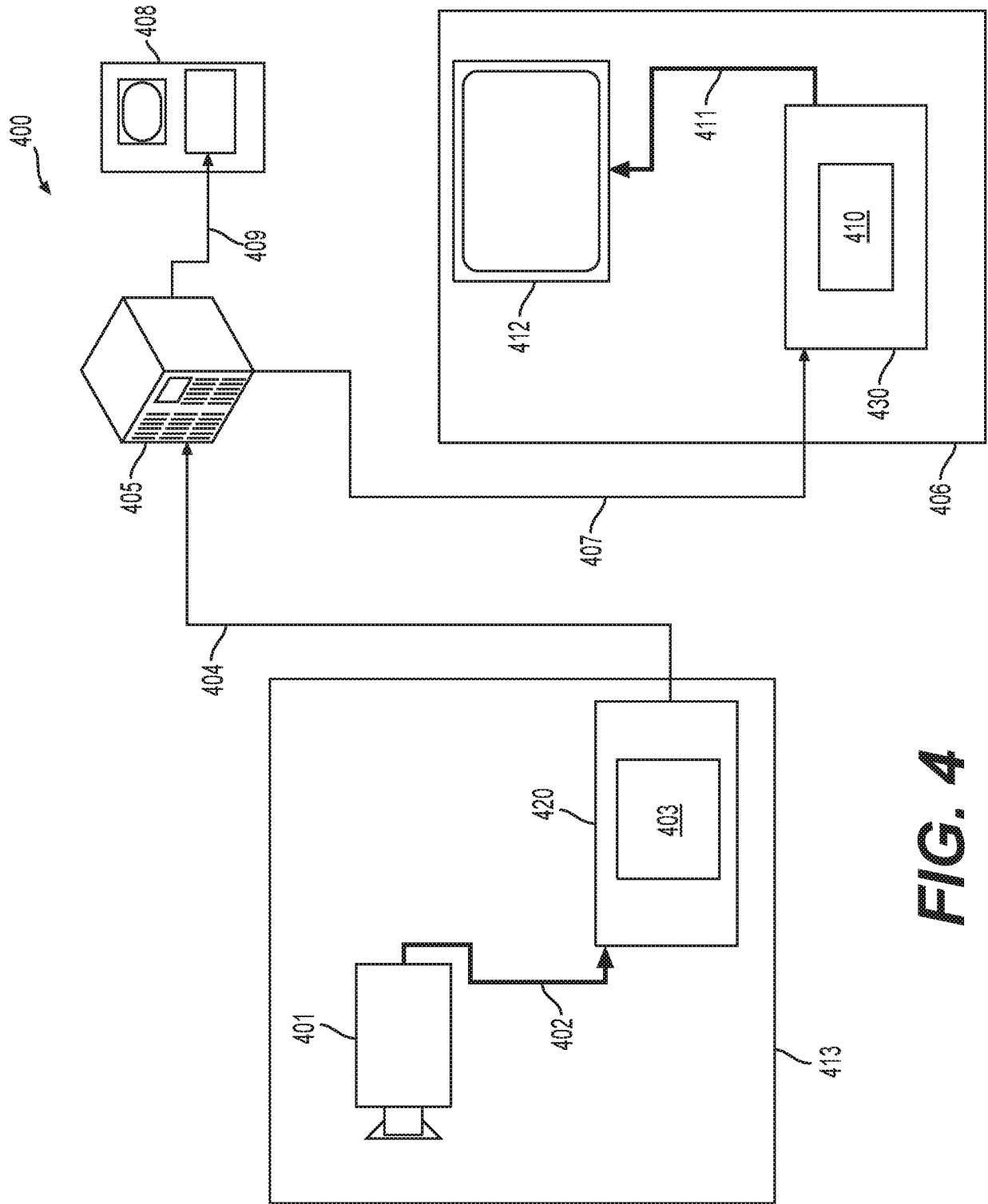

FIG. 4

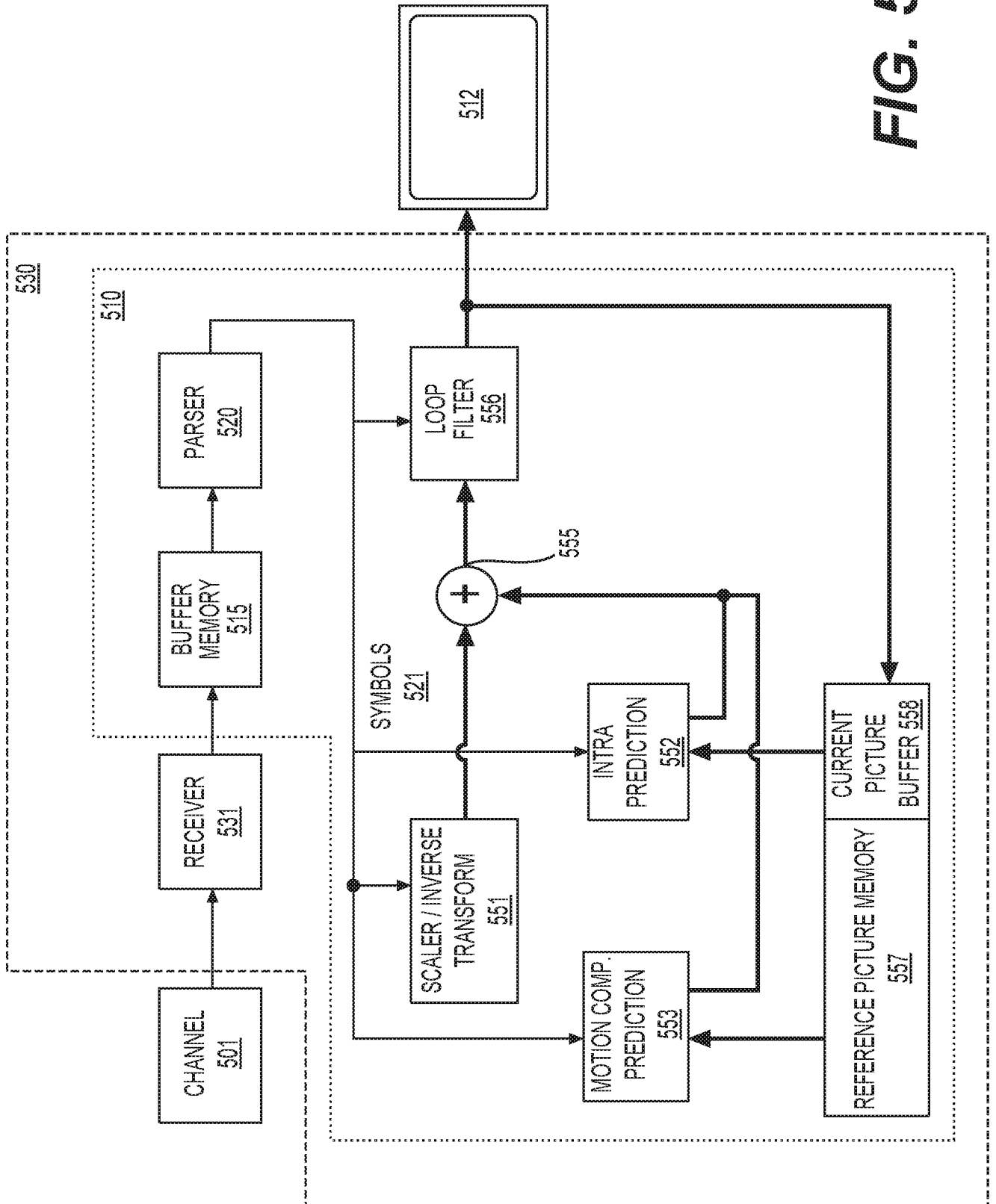

FIG. 5

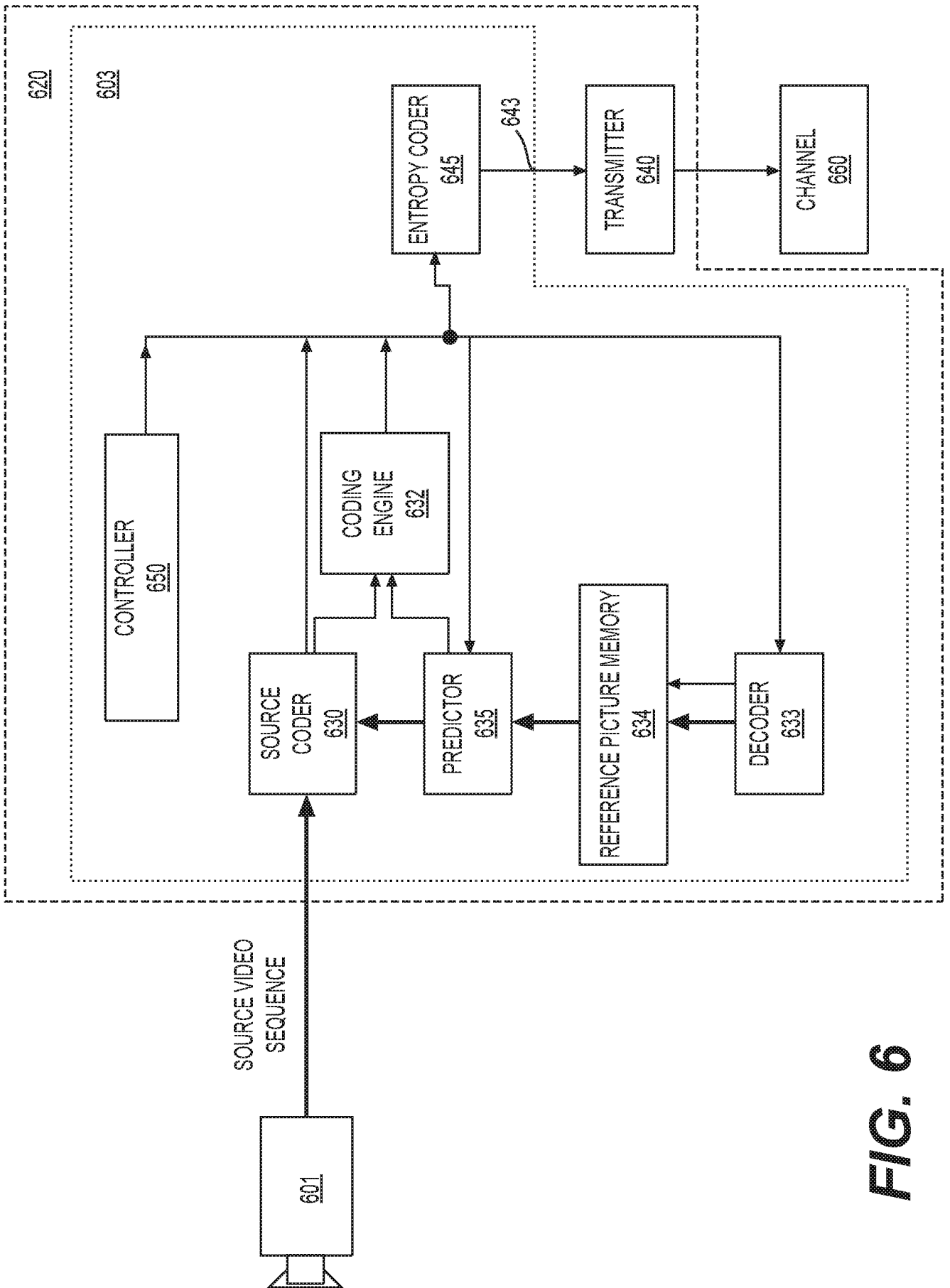

FIG. 6

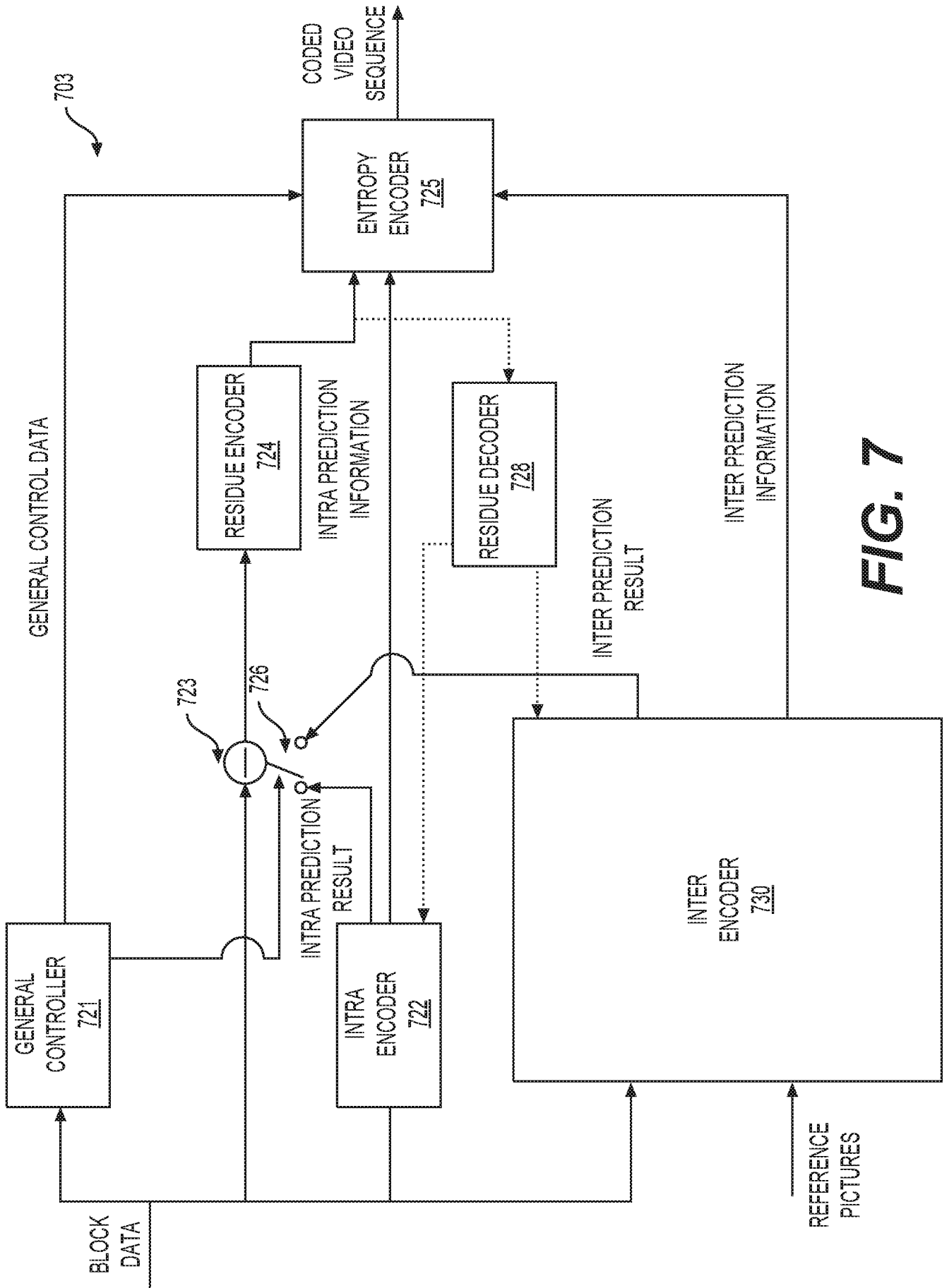

FIG. 7

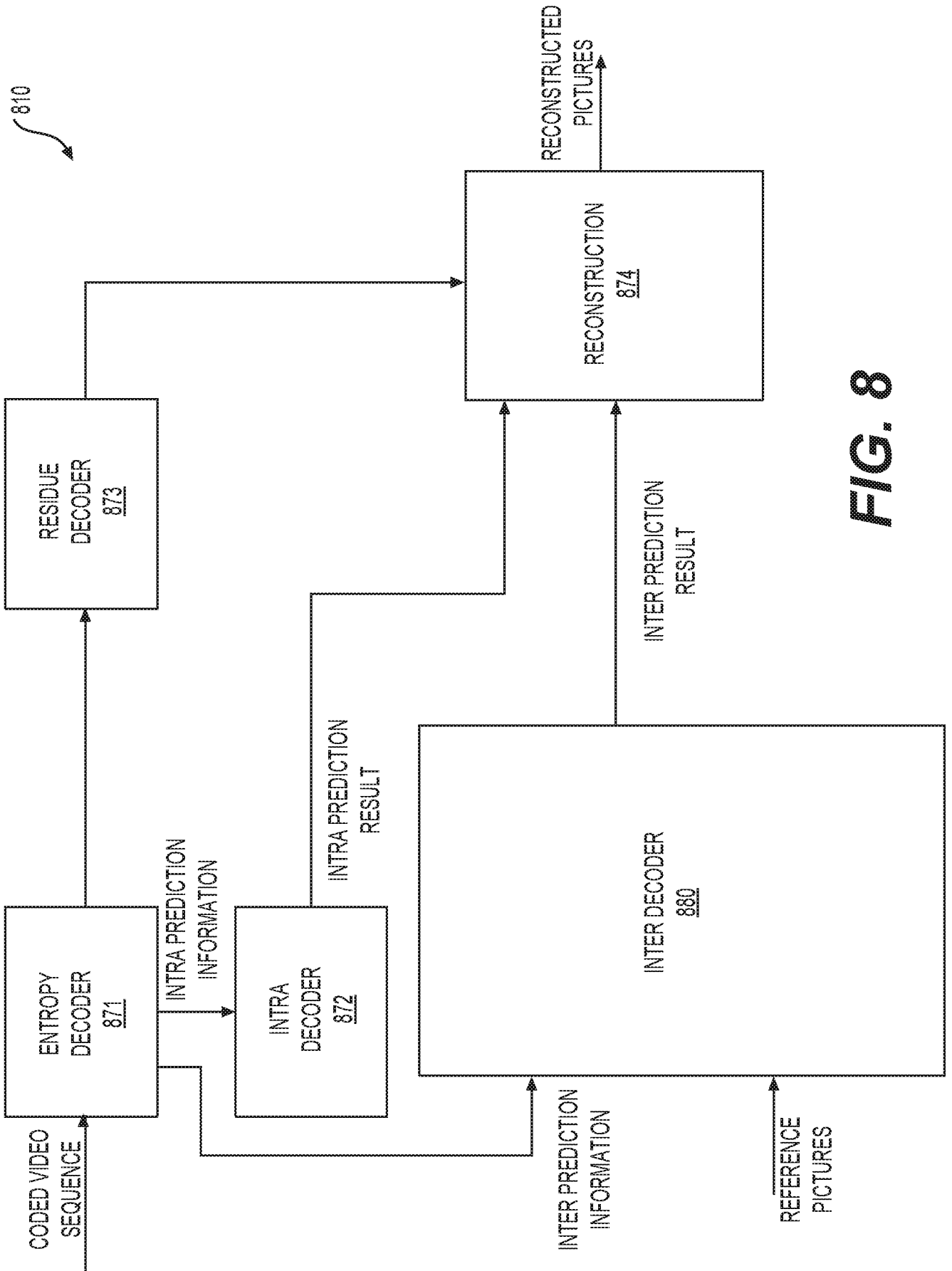

FIG. 8

H		H		H		H		H		H		H		H		H		H		
	H		H		H		H		H		H		H		H		H		H	
		H		H		H		H		H		H		H		H		H		H
			H			H			H			H			H			H		
				H			H			H			H			H			H	
					H				H				H				H			H
						H				H				H				H		
							H				H				H				H	
								H				H				H				H
									H				H				H			

V		V		V		V		V		V		V		V		V		V		V
	V		V		V		V		V		V		V		V		V		V	
		V		V		V		V		V		V		V		V		V		V
			V			V			V			V			V			V		
				V			V			V			V			V			V	
					V				V				V				V			V
						V				V				V				V		
							V				V				V				V	
								V				V				V				V
									V				V				V			

FIG. 10A

FIG. 10B

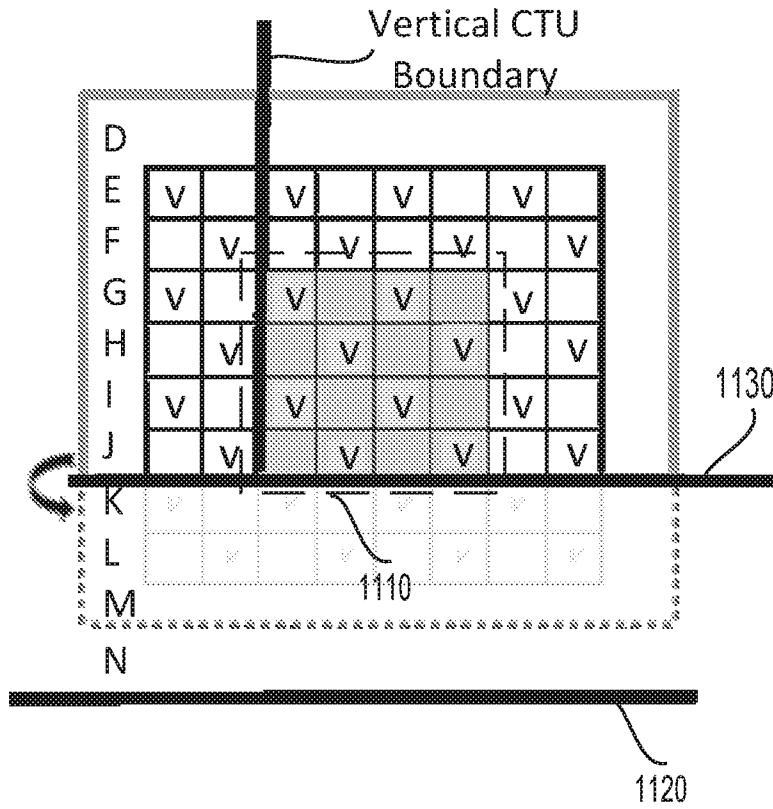

FIG. 11A

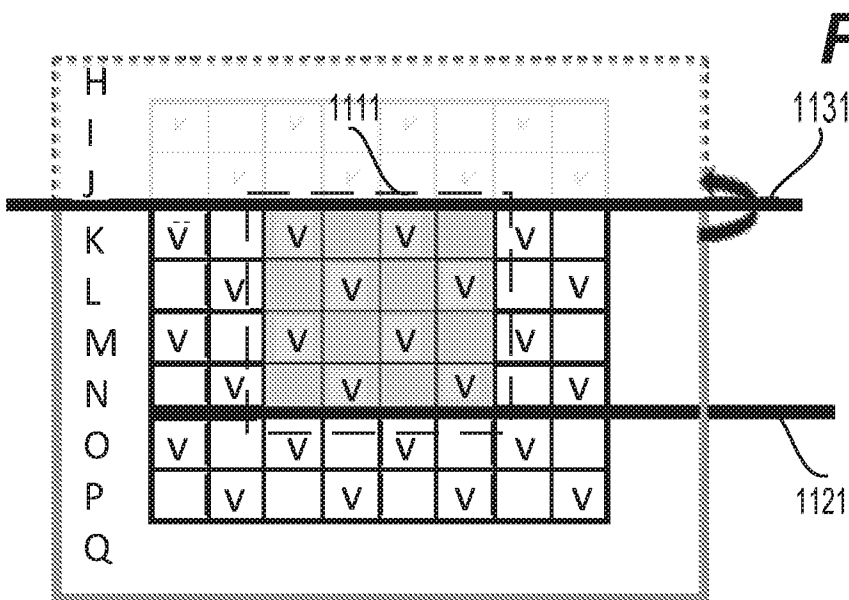

FIG. 11B

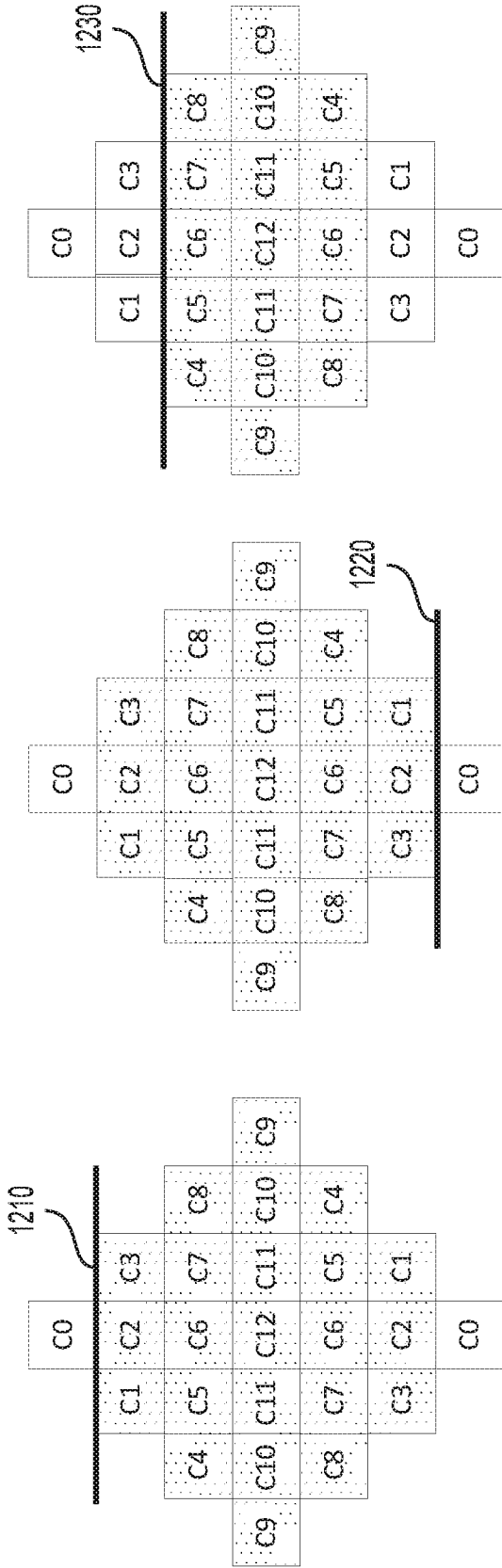

FIG. 12C

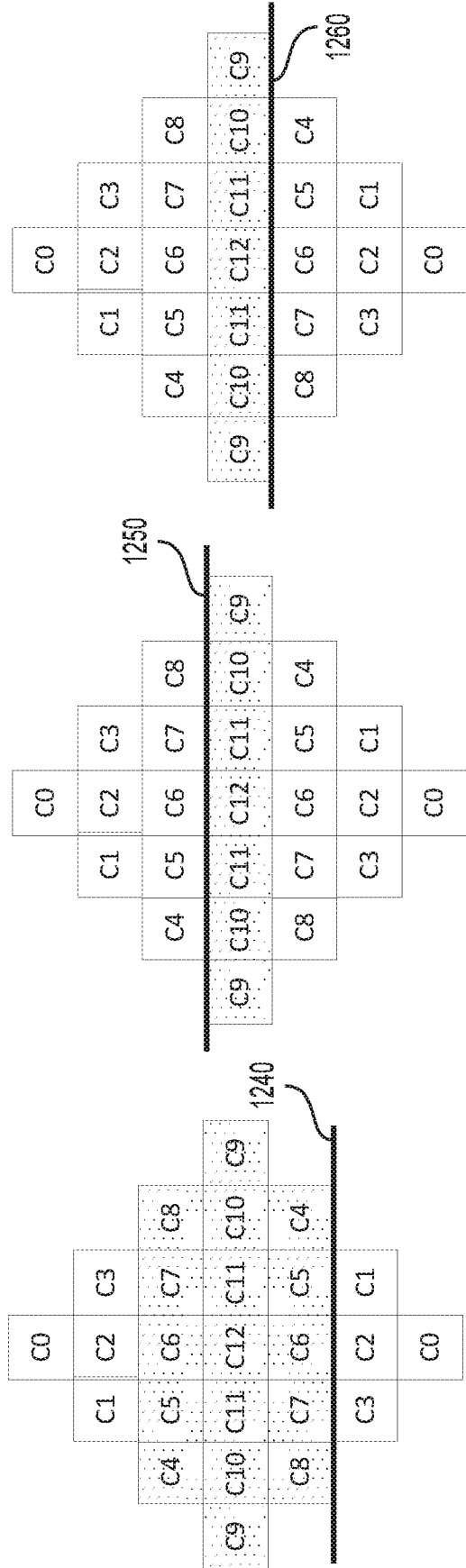

FIG. 12D

FIG. 12E

FIG. 12F

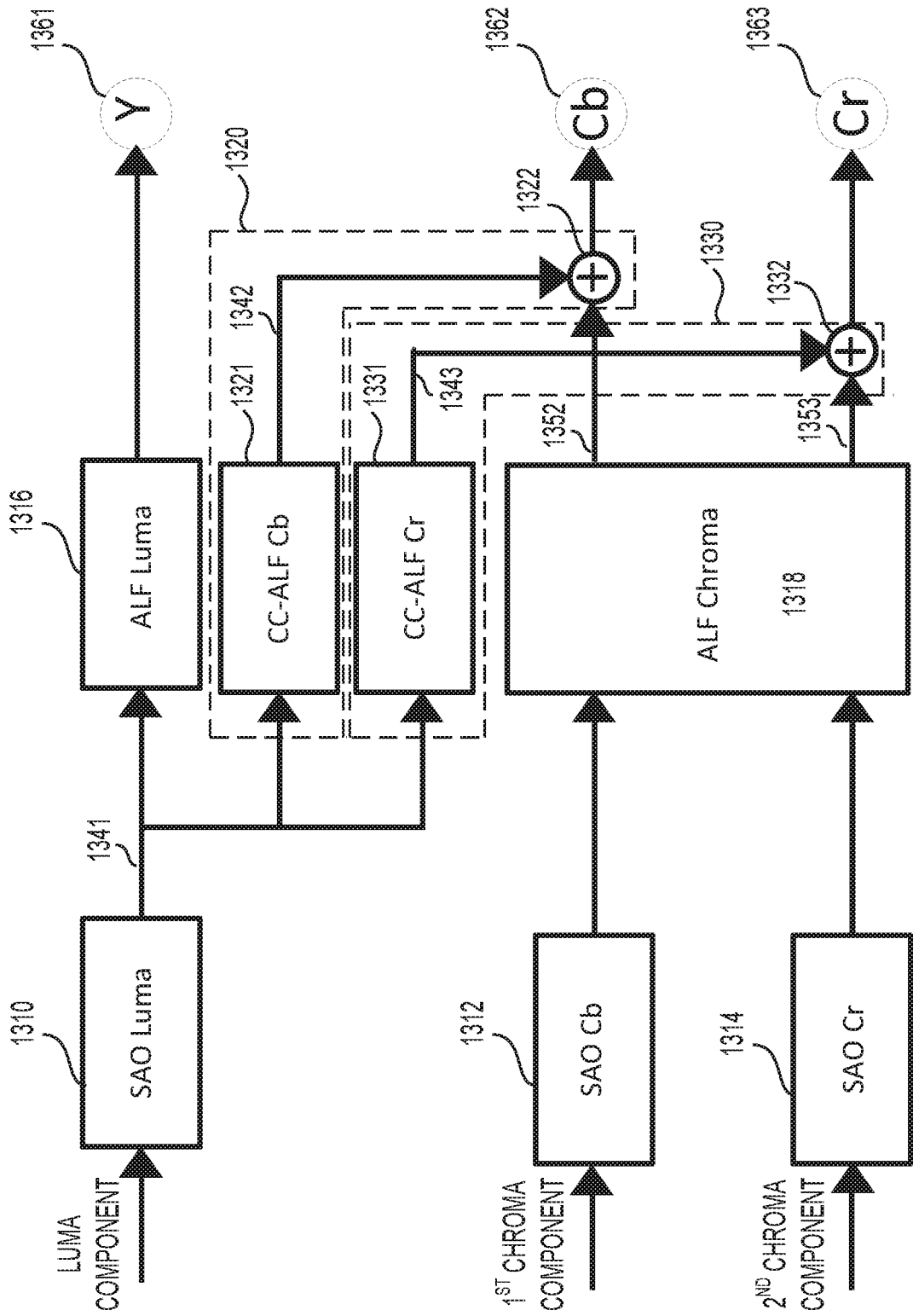

FIG. 13

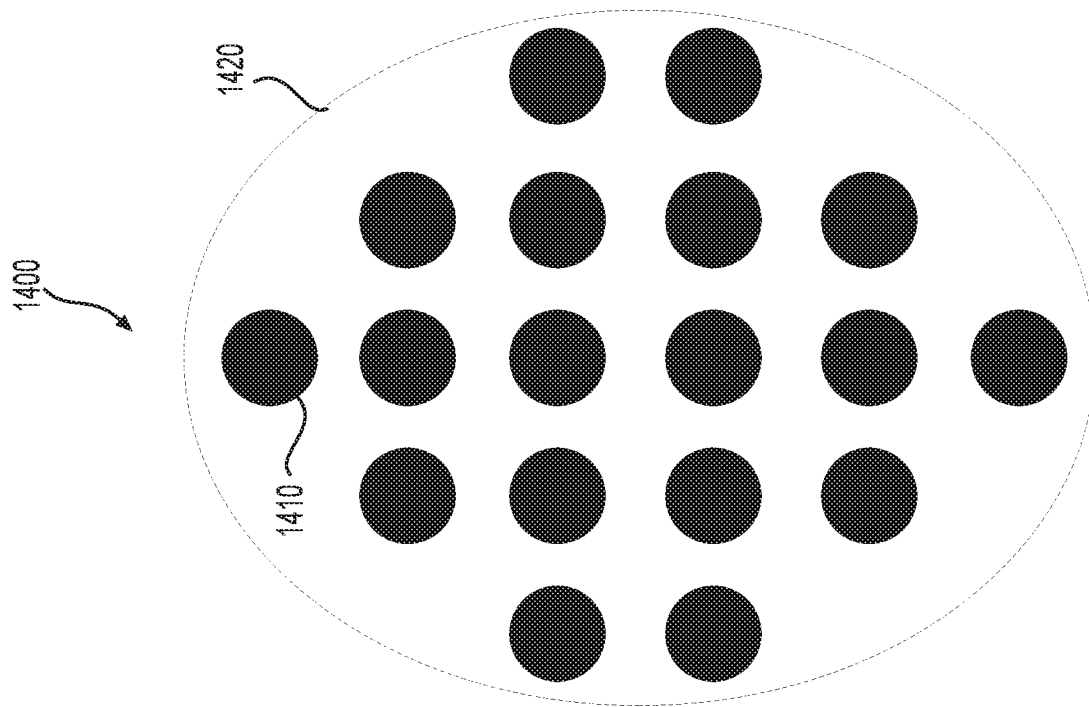

FIG. 14

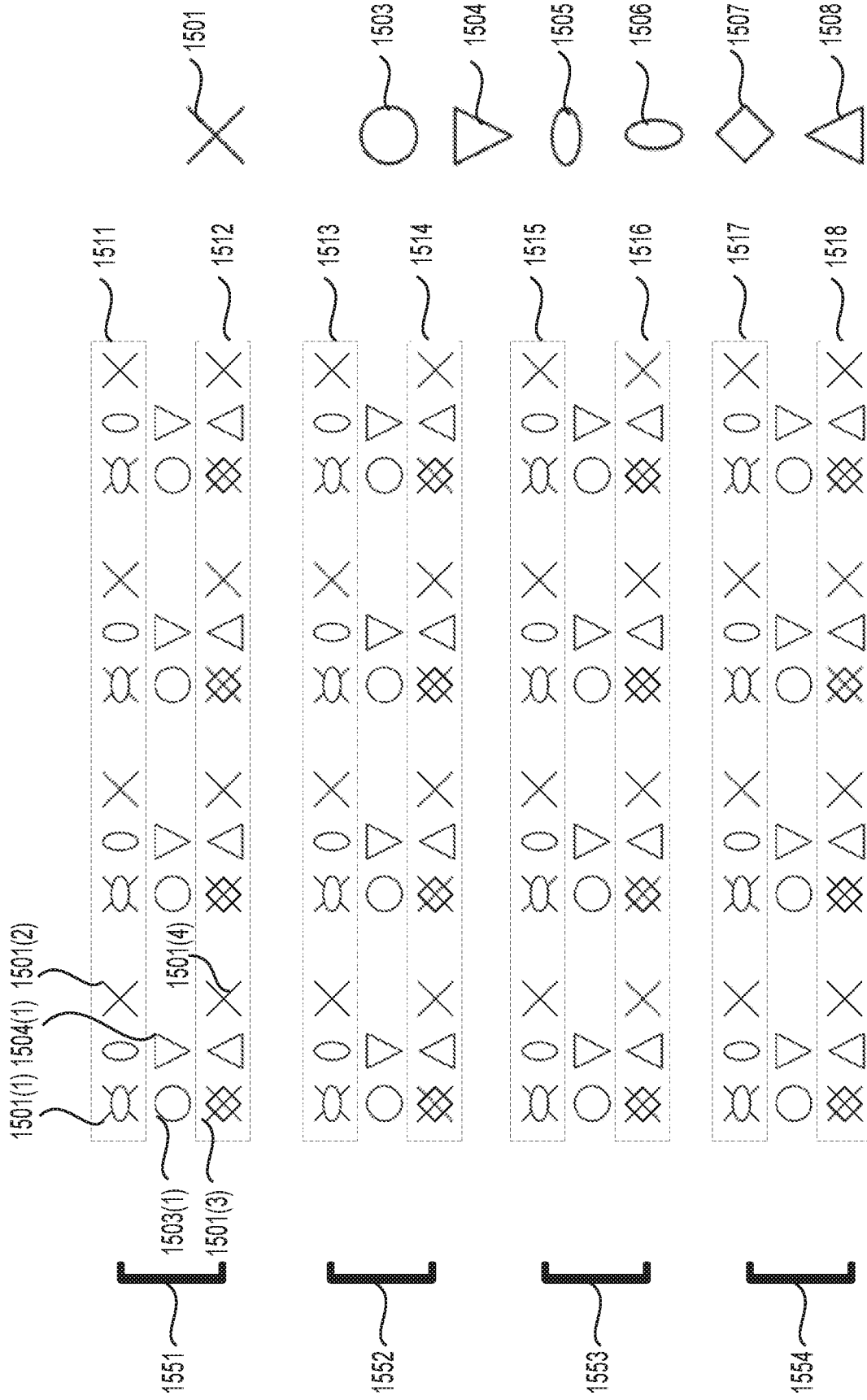

FIG. 15A

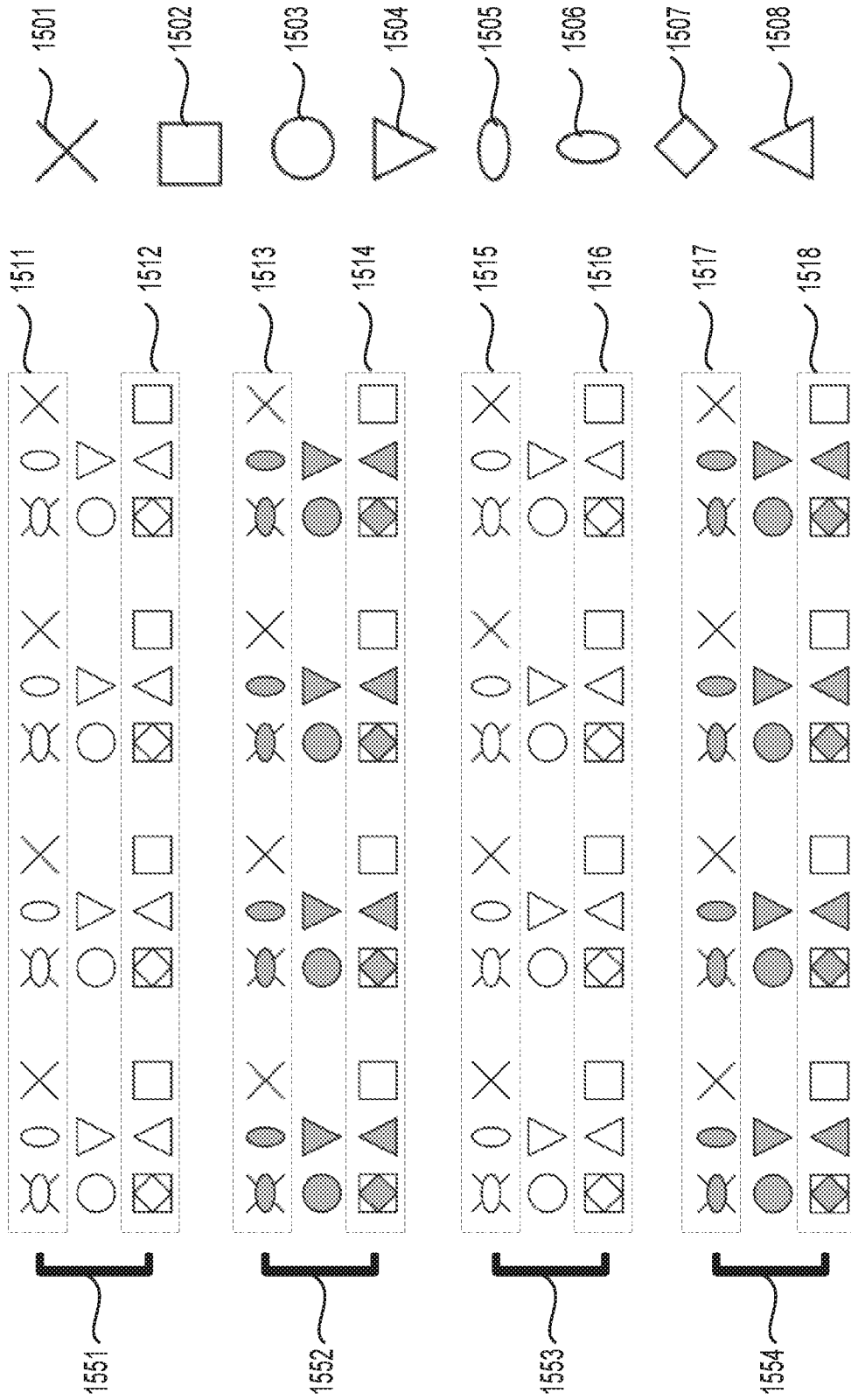

FIG. 15B

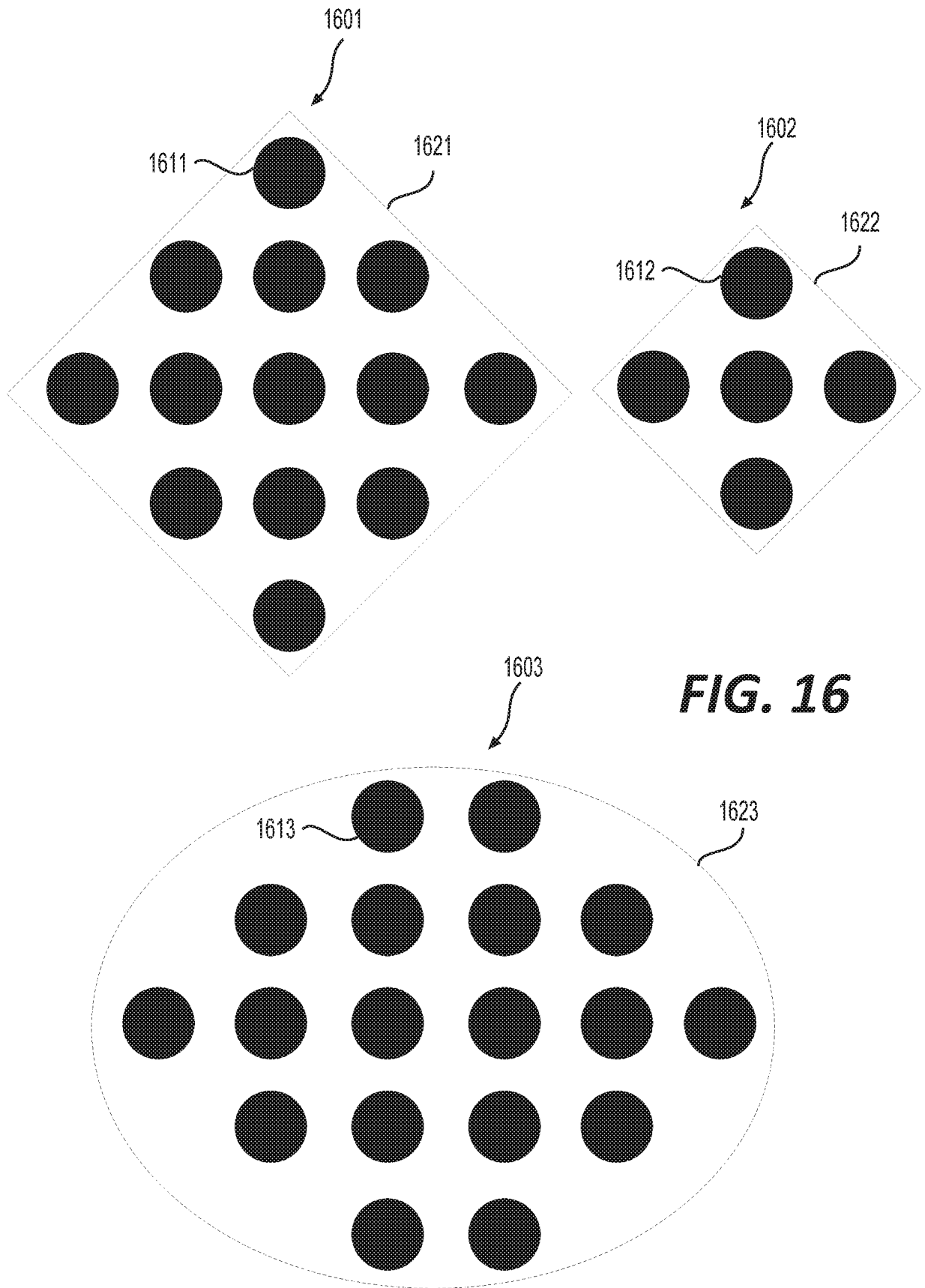
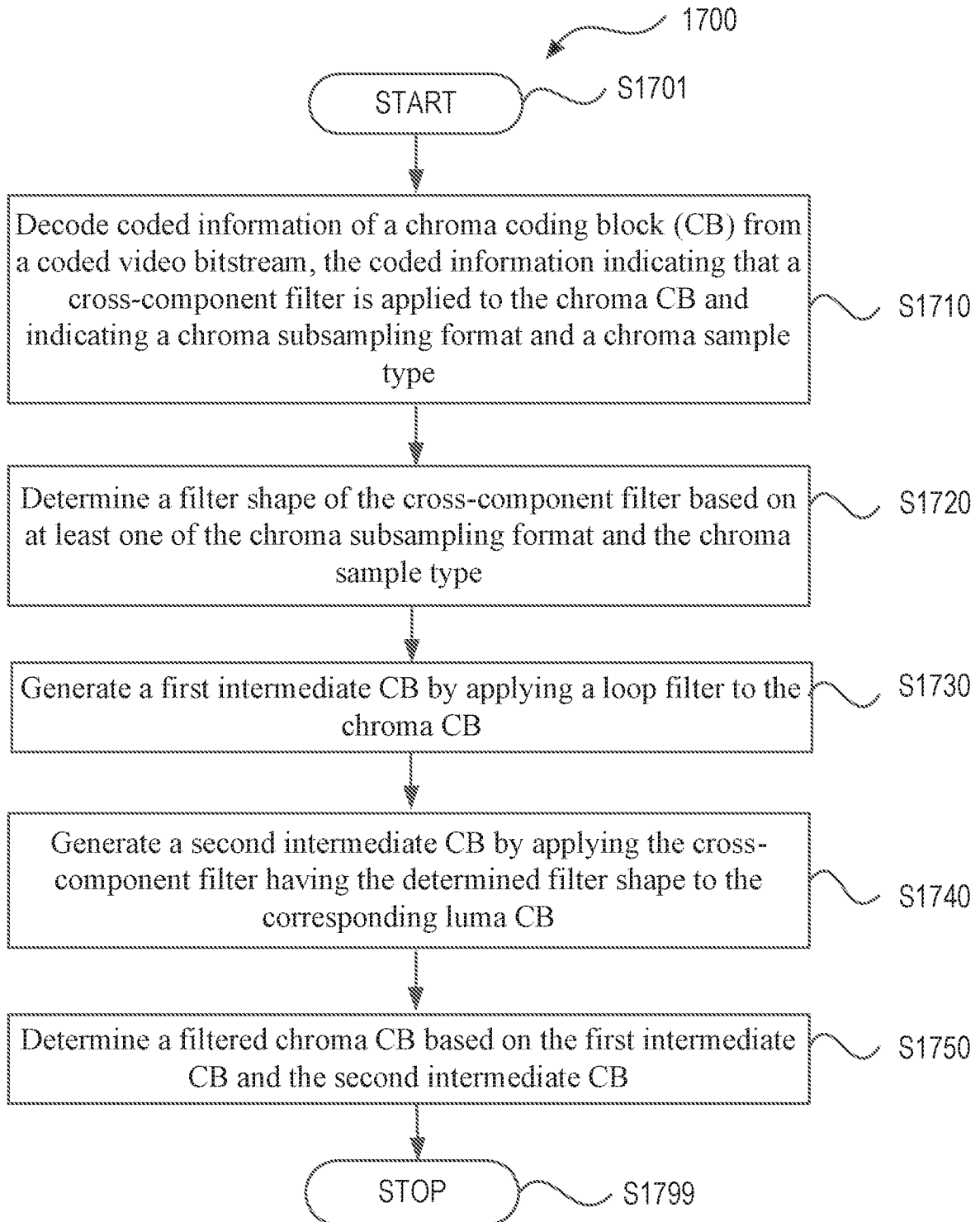

FIG. 16

**FIG. 17**

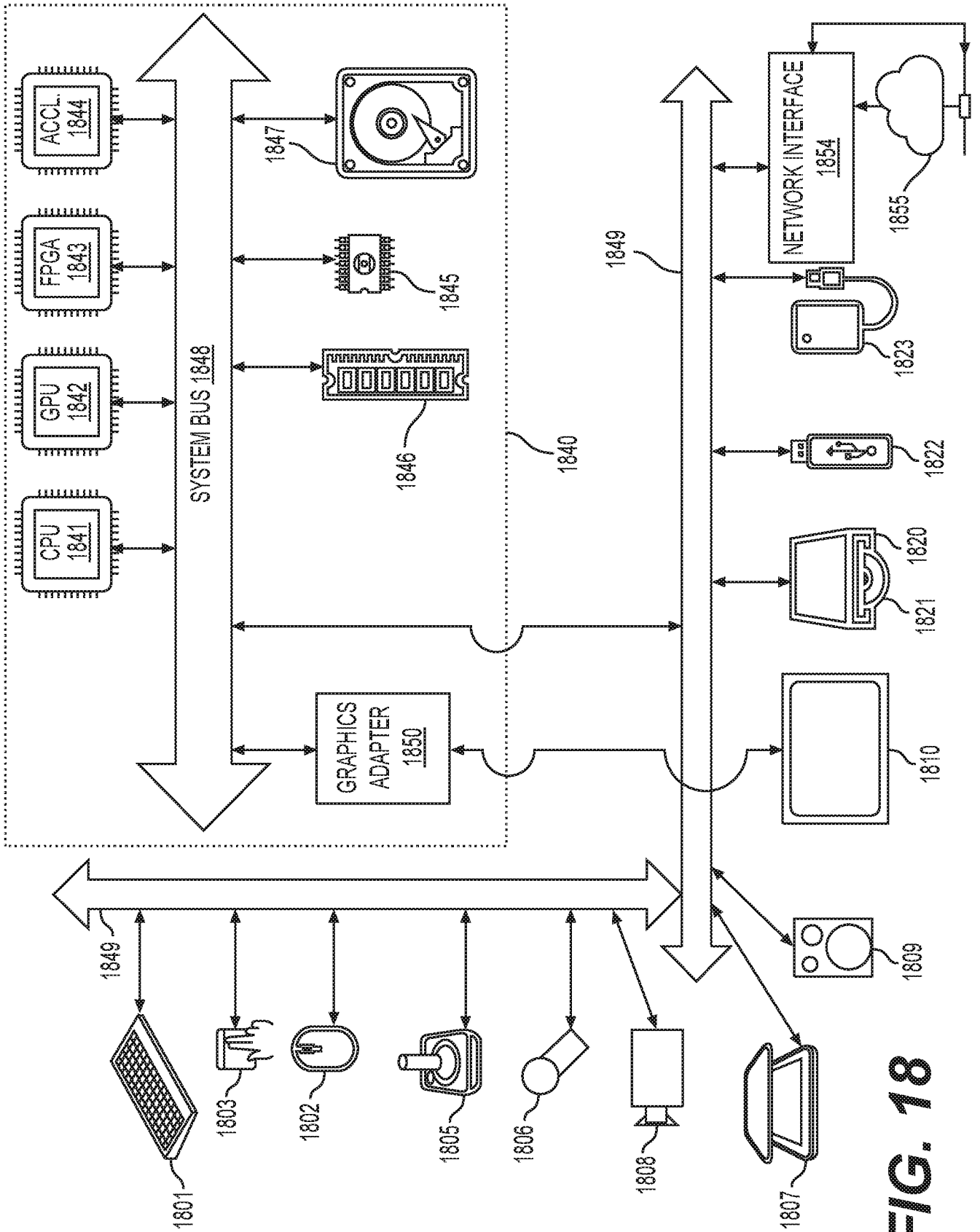

FIG. 18

INTERNATIONAL SEARCH REPORT

International application No.

PCT/US 20/50116

A. CLASSIFICATION OF SUBJECT MATTER
IPC - H04N 19/117, H04N 19/186 (2021.01)

CPC - H04N 19/635, H04N 19/513, H04N 19/82, H04N 19/117, H04N 19/186

According to International Patent Classification (IPC) or to both national classification and IPC

B. FIELDS SEARCHED

Minimum documentation searched (classification system followed by classification symbols)
See Search History document

Documentation searched other than minimum documentation to the extent that such documents are included in the fields searched
See Search History document

Electronic data base consulted during the international search (name of data base and, where practicable, search terms used)
See Search History document

C. DOCUMENTS CONSIDERED TO BE RELEVANT

Category*	Citation of document, with indication, where appropriate, of the relevant passages	Relevant to claim No.
Y	US 2018/0063527 A1 (QUALCOMM Incorporated), 01 March 2018 (01.03.2018), entire document, especially Abstract; para [0065]-[0068], [0084]-[0088], [0094]-[0099]	1-9 and 14-20
Y	US 2018/0288441 A1 (QUALCOMM Incorporated), 04 October 2018 (04.10.2018), entire document, especially Abstract; para [0023]-[0024], [0095]-[0097], [0134]-[0138]	1-9 and 14-20
Y	Sullivan et al. "Meeting Report of the 15th Meeting of the Joint Video Experts Team (JVET)." In: Joint Video Experts Team (JVET) of ITU-T SG 16 WP 3 and ISO/IEC JTC 1/SC 29/WG 11, 15th Meeting: Gothenburg, SE, 3-12 July 2019 [Shortened- pages 1, 188-198], [online] [retrieved on 08 January 2021 (08.01.2021)] Retrieved from the Internet < URL: https://www.itu.int/wftp3/av-arch/jvet-site/2019_07_O_Gothenburg/JVET-O_Logistics.docx>, entire document, especially page 1, 188, 194-195	6, 8 and 19
A	US 2017/0244975 A1 (MediaTek Singapore Pte. Ltd), 24 August 2017 (24.08.2017), entire document	1-9 and 14-20
A	US 2016/0105685 A1 (QUALCOMM Incorporated), 14 April 2016 (14.04.2016), entire document	1-9 and 14-20

Further documents are listed in the continuation of Box C.

See patent family annex.

* Special categories of cited documents:	"T" later document published after the international filing date or priority date and not in conflict with the application but cited to understand the principle or theory underlying the invention
"A" document defining the general state of the art which is not considered to be of particular relevance	"X" document of particular relevance; the claimed invention cannot be considered novel or cannot be considered to involve an inventive step when the document is taken alone
"D" document cited by the applicant in the international application	"Y" document of particular relevance; the claimed invention cannot be considered to involve an inventive step when the document is combined with one or more other such documents, such combination being obvious to a person skilled in the art
"E" earlier application or patent but published on or after the international filing date	"&" document member of the same patent family
"L" document which may throw doubts on priority claim(s) or which is cited to establish the publication date of another citation or other special reason (as specified)	
"O" document referring to an oral disclosure, use, exhibition or other means	
"P" document published prior to the international filing date but later than the priority date claimed	

Date of the actual completion of the international search
07 January 2021

Date of mailing of the international search report
04 FEB 2021

Name and mailing address of the ISA/US
Mail Stop PCT, Attn: ISA/US, Commissioner for Patents
P.O. Box 1450, Alexandria, Virginia 22313-1450
Facsimile No. 571-273-8300

Authorized officer
Lee Young
Telephone No. PCT Helpdesk: 571-272-4300

INTERNATIONAL SEARCH REPORT

International application No.

PCT/US 20/50116

Box No. II Observations where certain claims were found unsearchable (Continuation of item 2 of first sheet)

This international search report has not been established in respect of certain claims under Article 17(2)(a) for the following reasons:

1. Claims Nos.:
because they relate to subject matter not required to be searched by this Authority, namely:

2. Claims Nos.:
because they relate to parts of the international application that do not comply with the prescribed requirements to such an extent that no meaningful international search can be carried out, specifically:

3. Claims Nos.:
because they are dependent claims and are not drafted in accordance with the second and third sentences of Rule 6.4(a).

Box No. III Observations where unity of invention is lacking (Continuation of item 3 of first sheet)

This International Searching Authority found multiple inventions in this international application, as follows:

— (See Continuation in Supplemental Box) —

1. As all required additional search fees were timely paid by the applicant, this international search report covers all searchable claims.
2. As all searchable claims could be searched without effort justifying additional fees, this Authority did not invite payment of additional fees.
3. As only some of the required additional search fees were timely paid by the applicant, this international search report covers only those claims for which fees were paid, specifically claims Nos.:
4. No required additional search fees were timely paid by the applicant. Consequently, this international search report is restricted to the invention first mentioned in the claims; it is covered by claims Nos.:
claims 1-9 and 14-20

- Remark on Protest**
- The additional search fees were accompanied by the applicant's protest and, where applicable, the payment of a protest fee.
 - The additional search fees were accompanied by the applicant's protest but the applicable protest fee was not paid within the time limit specified in the invitation.
 - No protest accompanied the payment of additional search fees.

INTERNATIONAL SEARCH REPORT

International application No.

PCT/US 20/50116

Continuation of:

Box III. Observations where unity of invention is lacking

This application contains the following inventions or groups of inventions which are not so linked as to form a single general inventive concept under PCT Rule 13.1. In order for all inventions to be searched, the appropriate additional search fees must be paid.

Group I- claims 1-9 and 14-20 method and apparatus for video decoding by determining filter shape of the cross-component filter.

Group II- claims 10-13 are directed to a method for video decoding in a decoder by applying a down-sampling filter.

The inventions listed as Groups I-II do not relate to a single general inventive concept under PCT Rule 13.1 because, under PCT Rule 13.2, they lack the same or corresponding special technical features for the following reasons:

Special Technical Features:

The invention of Group I included the features of the coded information further indicating a chroma subsampling format and a chroma sample type that indicates a relative position of a chroma sample with respect to at least one luma sample in a corresponding luma CB; determining a filter shape of the cross-component filter based on at least one of the chroma subsampling format and the chroma sample type; generating a second intermediate CB by applying the cross-component filter having the determined filter shape to the corresponding luma CB, not required by group II.

The invention of Group II included the features of generating a down-sampled luma CB by applying a down-sampling filter to the corresponding luma CB, a chroma horizontal subsampling factor, and a chroma vertical subsampling factor between the chroma CB and the down-sampled luma CB being one; generating a second intermediate CB by applying the cross-component filter to the downsampled luma CB, a filter shape of the cross-component filter being independent of a chroma subsampling format and a chroma sample type of the chroma CB, the chroma sample type indicating a relative position of a chroma sample with respect to at least one luma sample in the corresponding luma CB, not required group I.

Common Technical Features

Groups I-II share the features of decoding coded information of a chroma coding block (CB) from a coded video bitstream, the coded information indicating that a cross-component filter is applied to the chroma CB; generating a first intermediate CB by applying a loop filter to the chroma CB.

However, the shared technical features do not represent a contribution over prior art as being obvious over US 2017/0244975 A1 (MediaTek Singapore Pte. Ltd), 24 August 2017 (24.08.2017) in view of US 2016/0105685 A1 (QUALCOMM Incorporated), 14 April 2016 (14.04.2016).

MediaTek Singapore Pte. Ltd teaches decoding coded information of a chroma coding block (CB) from a coded video bitstream, the coded information indicating that a cross-component filter is applied to the chroma CB (para [0015], [0018], [0042]-[0046] - mode flag to indicate whether to apply the cross-component residual prediction can be signaled at TU level for each Intra coded CU; parameter derivation, the first prediction data and the second prediction data may correspond to subsampled or filtered motion compensation prediction blocks of the current block for the first component and the second component respectively; the first component may correspond to a first chroma component selected from UV or CrCb and the second component corresponds to a second chroma component selected from UV or CrCb respectively).

QUALCOMM Incorporated teaches generating a first intermediate CB by applying a loop filter to the chroma CB (para [0096]-[0098], [0132]-[0135] - Additional filters (in loop or post loop) may also be used in addition to the deblocking filter. Such filters are not shown for brevity, but if desired, may filter the output of summer 50 (as an in-loop filter); deblocking filter may also be applied to filter the decoded blocks in order to remove blockiness artifacts. Other loop filters (either in the coding loop or after the coding loop) may also be used to smooth pixel transitions, or otherwise improve the video quality).

As the common features were known in the art at the time of the invention, this cannot be considered a common technical feature that would otherwise unify the groups. Therefore, Groups I-II lack unity under PCT Rule 13.