



INTERNATIONAL APPLICATION PUBLISHED UNDER THE PATENT COOPERATION TREATY (PCT)

(51) International Patent Classification ⁶ : A61M 5/32	A1	(11) International Publication Number: WO 96/39215 (43) International Publication Date: 12 December 1996 (12.12.96)
<p>(21) International Application Number: PCT/US96/09446</p> <p>(22) International Filing Date: 5 June 1996 (05.06.96)</p> <p>(30) Priority Data: 08/465,587 5 June 1995 (05.06.95) US</p> <p>(60) Parent Application or Grant (63) Related by Continuation US 08/465,587 (CIP) Filed on 5 June 1995 (05.06.95)</p> <p>(71) Applicant (for all designated States except US): BOARD OF REGENTS, THE UNIVERSITY OF TEXAS SYSTEM [US/US]; 201 West 7th Street, Austin, TX 78701 (US).</p> <p>(72) Inventors; and (75) Inventors/Applicants (for US only): TCHOLAKIAN, Robert [US/US]; 3745 Tangle Street, Houston, TX 77005 (US). RAAD, Issam [US/US]; 7615 Del Rey Lane, Houston, TX 77071 (US).</p> <p>(74) Agent: PARKER, David, L.; Arnold, White & Durkee, P.O. Box 4433, Houston, TX 77210 (US).</p>		<p>(81) Designated States: CA, JP, US, European patent (AT, BE, CH, DE, DK, ES, FI, FR, GB, GR, IE, IT, LU, MC, NL, PT, SE).</p> <p>Published <i>With international search report.</i></p>
<p>(54) Title: A MULTIPURPOSE ANTI-MICROBIAL SILASTIC SHEATH SYSTEM FOR THE PREVENTION OF DEVICE-RELATED INFECTIONS</p>		
<p>(57) Abstract</p> <p>The present invention relates generally to indwelling medical devices. In particular, there is provided a device constructed from permeable or impermeable material having a pharmacologically active agent (7) or ingredient layer (3, 10) surrounding the device, and a sheath (2, 11) which is permeable to the pharmacologically active agent or ingredient. This construction provides a device that allows the pharmacologically active agent or ingredient located between the catheter tube (1) and the sheath (2) to slowly diffuse through the sheath and/or inner tube (4), thus inhibiting microbial infection on the outer surface and lumen of the catheter (5, 13).</p>		

FOR THE PURPOSES OF INFORMATION ONLY

Codes used to identify States party to the PCT on the front pages of pamphlets publishing international applications under the PCT.

AM	Armenia	GB	United Kingdom	MW	Malawi
AT	Austria	GE	Georgia	MX	Mexico
AU	Australia	GN	Guinea	NE	Niger
BB	Barbados	GR	Greece	NL	Netherlands
BE	Belgium	HU	Hungary	NO	Norway
BF	Burkina Faso	IE	Ireland	NZ	New Zealand
BG	Bulgaria	IT	Italy	PL	Poland
BJ	Benin	JP	Japan	PT	Portugal
BR	Brazil	KE	Kenya	RO	Romania
BY	Belarus	KG	Kyrgyzstan	RU	Russian Federation
CA	Canada	KP	Democratic People's Republic of Korea	SD	Sudan
CF	Central African Republic	KR	Republic of Korea	SE	Sweden
CG	Congo	KZ	Kazakhstan	SG	Singapore
CH	Switzerland	LI	Liechtenstein	SI	Slovenia
CI	Côte d'Ivoire	LK	Sri Lanka	SK	Slovakia
CM	Cameroon	LR	Liberia	SN	Senegal
CN	China	LT	Lithuania	SZ	Swaziland
CS	Czechoslovakia	LU	Luxembourg	TD	Chad
CZ	Czech Republic	LV	Latvia	TG	Togo
DE	Germany	MC	Monaco	TJ	Tajikistan
DK	Denmark	MD	Republic of Moldova	TT	Trinidad and Tobago
EE	Estonia	MG	Madagascar	UA	Ukraine
ES	Spain	ML	Mali	UG	Uganda
FI	Finland	MN	Mongolia	US	United States of America
FR	France	MR	Mauritania	UZ	Uzbekistan
GA	Gabon			VN	Viet Nam

- 1 -

DESCRIPTION**A MULTIPURPOSE ANTI-MICROBIAL SILASTIC SHEATH SYSTEM
FOR THE PREVENTION OF DEVICE-RELATED INFECTIONS****5 1. Field of the Invention**

The present invention relates generally to the field of medical devices. One particular application concerns catheters with pharmacologically active agent(s) or ingredient(s) layered between the lumen and external surfaces of the catheter, including
10 their application and preparation. The invention also concerns the field of long-term infection control in medical devices, as the described devices possess extended antimicrobial activity and hence, extended capacity to prevent/inhibit infection.

15 2. Description of the Related Art

Catheters used for vascular access, both arterial and venous, urethral, abdominal cavity tubing, drainage bags and various connectors are common sources of infection. In particular, a high percentage of patients who require long-term urinary catheters develop chronic urinary tract infections, frequently in conjunction with episodes of fever, chills
20 and flank pain. Such patients are at risk of developing bacteremia or chronic pyelonephritis, conditions of high morbidity and mortality. Thus, a desirable feature of urinary catheters is that they should provide some means of infection control.

One way to control bacterial infections is by providing, concurrent with the
25 catheter treatment, an antibiotic regimen. In addition to providing antimicrobial agents to combat catheter-related infections, it is sometimes desirable to deliver other agents such as anticoagulants and antifibrins as adjuncts to the antimicrobial agents to prevent thrombotic occlusions and microbial colonization on both the external and luminal surfaces.

30

- 2 -

It is further desired that delivery of these pharmacologically active agent(s) or ingredient(s) be maintained for a long duration of time, released in a relatively slow manner, and that the delivery be circumferential with the catheter or device rather than concentrated in particular areas. It is even further desired that the incorporation of the pharmacologically active agent(s) or ingredient(s) in a delivery system as described can be adapted to all catheters ranging from simple to complex ones, and from adult to pediatric sizes. This also includes the various medical devices this technology can advance.

Some attempts have been made to incorporate an antimicrobial delivery system into a catheter, including those directed to adhering a pharmacologically active agent or ingredient to the catheter itself. Laurin *et al.*, U.S. Patent No. 4,677,143, relates to the application of a coating of an antimicrobial agent mixed with a resin to the exterior of medical device, such as a catheter.

The problem with surface bonding is that it is limited to short-term delivery of the pharmacologically active agent or ingredient. This residual antimicrobial activity after catheter removal (Table 2, step F) was demonstrated in detail in FIG. 12. The antimicrobials used were minocycline/rifampin (2:1). After plating the catheters (as FIG. 2 and prototype 2) with silicone embedded antimicrobial jacket in agar (as per Table 2), the catheters were reimplanted after each 7-day cycle and the used plates, where the catheters used to be, were kept and observed (Table 2, step F) to determine whether the residual antimicrobial agents released when the catheter was implanted in the agar will still inhibit bacterial recolonization of the zone of inhibition in the absence of the catheter. FIG. 12 shows that the antimicrobial agents released from the catheter when present prevented recolonization of the zone of inhibition for up to 90+ days. This is because the surfactants used to facilitate bonding between the pharmacologically active agent or ingredient and the catheter, such as tridodecyl-methylammonium chloride (TIDMAC) or benzalkonium chloride, have limited effectiveness due to their short binding duration. Furthermore, the direct contact between these pharmacologically active agent(s)

- 3 -

or ingredient(s) with biological fluids in such devices facilitates rapid depletion of the active agent(s) or ingredient(s).

Wepsic *et al.*, U.S. Patent No. 3,598,127 relates to an antibacterial agent placed
5 as a powder in longitudinal grooves between the catheter wall and a polysiloxane rubber
layer. The polysiloxane layer was permeable to the antibacterial agent, allowing the
agent to diffuse through the layer. The Wepsic *et al.* patent used longitudinally spaced
grooves to contain the powdered bacterial agent. This is believed to be an undesirable
and less effective arrangement, as it does not result in even diffusion around the
10 circumference of the catheter or prolong the antimicrobial activity of the catheter beyond
that of the surface coated catheters. Furthermore, the presence of the powder makes it
very difficult to manufacture this design and reproduce a unit that consistently produces
reproducible results. This is due in part to the uncontrolled powder concentration in the
grooves.

15

Although others have addressed the problem of incorporating a delivery system
for pharmacologically active agent(s) or ingredient(s) in a catheter, satisfactory solutions
have not yet been achieved. The present invention is directed to providing such a
solution.

20

SUMMARY OF THE INVENTION

The present invention seeks to overcome these and other drawbacks inherent in
the prior art by providing a medical construct that is surrounded with a layer of
25 pharmacologically active agent or ingredient which, in turn, is surrounded by a sheath
composed of silicone. This layer may be permeable to the pharmacologically active
agent(s) or ingredient(s), and provides a safety barrier between the pharmacologically
active agent(s) or ingredient(s) embedded in the device and the surrounding biological
fluids. The devices of the present invention also provide the advantage of allowing

- 4 -

diffusion of the pharmacologically active agent or ingredient both into the lumen of the device and outward to the exterior surface of the device.

In one embodiment, the present invention comprises an indwelling medical
5 construct having an elongated, hollow lumen, providing an inner shell to the device. This
inner shell is surrounded by selected pharmacologically active agent(s) or ingredient(s).
These agent(s) or ingredient(s) may either be embedded in a pharmacologically active
agent-permeable material, such as silicone, or may take the form of a powder layer.
These pharmacologically active agent(s) or ingredient(s), in turn, are surrounded by a solid
10 sheath of silicone, or other pharmacologically active agent-permeable material. The
sheath thus defines a space between said device and said sheath. The agent(s) or
ingredient(s) may thus slowly diffuse through the inner device or tube and/or sheath. The
diffusion of the pharmacologically active agent(s) or ingredient(s) through the sheath
provides a circumferential layer on the surface of the device to inhibit microbial
15 colonization. In some embodiments, the sheath is constructed from polysiloxane rubber.
Other materials may, however, be used as long as they are biologically inert. Both
materials that allow for the diffusion of pharmacologically active agent(s) or ingredient(s)
(having a molecular weight less than or about 2,000 kDa), may be used in conjunction
with the invention, selection depending primarily on the desired use of the device.

20

An alternative embodiment of the present invention uses a jacket of silicone
embedded with at least one pharmacologically active agent or ingredient as a sandwiched
layer between the inner surface that surrounds the lumen, and the external layer
comprising the sheath, in lieu of a "sandwiched" crystalline layer of pharmacologically
25 active agent or ingredient. This jacket embedded with pharmacologically active
ingredient(s) allows said pharmacologically active ingredient(s) to slowly diffuse through
the jacket.

Thus, the present invention provides an indwelling medical construct which
30 incorporates a system for delivering pharmacologically active agent(s) or ingredient(s) in a

- 5 -

slow, controlled manner over a long duration of time. In addition, pharmacologically active agent(s) or ingredient(s) are substantially evenly distributed around the entire circumference of the device and/or throughout the space between the device and the sheath.

5

The present invention may be adapted to all indwelling medical devices, and existing devices may be modified to contain the delivery system described by the present invention.

10

The construction of the antimicrobial jacket and surrounding sheath, although described for catheters, may apply to any medically implantable device.

15

Furthermore, the constructs of the invention do not have to be constructed from permeable material, but may in some embodiments be constructed of semi-permeable materials, or a combination of both permeable and semi-permeable materials. Some embodiments of the device may be comprised of material that is less permeable than silicone, or not permeable at all, to the particular pharmacologically active agent used, yet the device can be surfaced with an antimicrobial agent bonded with silicone and covered with a silicone sheath. Such semi-permeable or non-permeable device materials include

20

teflon, polyurethane, carbothane, polyethylene, tygon and various other plastic materials used in medical devices.

25

The construct of the invention may be fashioned to provide any variety of catheter desired, whether the catheters are constructed from permeable, semi-permeable or non-permeable materials. If drug diffusion is desired into both the lumen of the catheter and to the surface of the catheter, the catheter tube material selected should at least be semi-permeable to the pharmacologically active agent selected. If drug diffusion is desired to the surface of the catheter or device, such catheter tube or device material can be constructed from the various non-permeable plastics used in medical devices.

30

- 6 -

Generally stated, in most embodiments of the invention, the pharmacologically active substances of the catheter diffuse through the sheath and surround the circumference or surface of the catheter, thus providing a protective zone of antimicrobials. Where the inner jacket/coating of the catheter lumen is of a permeable or semi-permeable material, the antimicrobial will also diffuse into the lumen of the catheter, thus providing still further anti-infection control and suppression of intraluminal colonization of bacteria.

The construct of the invention may also be constructed of pharmacologically active agent-permeable material which is embedded with at least one pharmacologically active agent or ingredient. Additionally, the sheath of the device may be constructed of pharmacologically active agent-permeable material which is embedded or impregnated with at least one pharmacologically active agent or ingredient. This embodiment of the invention even further allows for the slow diffusion of the pharmacologically active agent(s) or ingredient(s) through the sheath and/or into the lumen of the catheter or device.

BRIEF DESCRIPTION OF THE DRAWINGS

The following drawings form part of the present specification and are included to further demonstrate certain aspects of the present invention. The invention may be better understood by reference to one or more of these drawings in combination with the detailed description of specific embodiments presented herein:

FIG. 1 is a cross section of a catheter (1) according to the invention having a silicone sheath jacket on the exterior surface (2) with a pharmacologically active antimicrobial agent (crystalline form) (3) sandwiched by an inner (luminal) layer of silastic (4) that forms the lumen of the catheter (5).

- 7 -

FIG. 2 is a cross section of a catheter according to the present invention having a silastic sheath jacket on the exterior surface (6) with a pharmacologically active antimicrobial agent totally embedded in silicone to form layer (7) sandwiched by an inner (luminal) layer of silicone (*i.e.*, an inner sheath) (8) that surrounds the lumen of the catheter (9). The silastic sheath (6) and the luminal sheath (8) may also be embedded or coated with at least one pharmacologically active agent or ingredient, or more such agent(s) or ingredient(s).

FIG. 3 is a longitudinal cutaway of a catheter according to the present invention which contains a silicone jacket embedded with a pharmacologically active agent or ingredient (10), covered with an outer surface silicone sheath (11). Cutaway also shows inner luminal sheath (12). The silastic sheath (11) and the luminal sheath (12) may also be embedded, embedded or coated with at least one pharmacologically active agent or ingredient, or more such agent(s) or ingredient(s).

FIG. 4 is a longitudinal section of a catheter according to the present invention having a layer of pharmacologically active agent(s) or ingredient(s) (13) and a sheath (14) which does not extend for the full length of the catheter.

FIG. 5 is a longitudinal section of a catheter according to the present invention having a layer of pharmacologically active agent(s) or ingredient(s) (15) and a sheath (16) coextensive with the length of the catheter.

FIG. 6 demonstrates the effect of various sterilization methods on silicone sheathed antimicrobial (minocycline/rifampin; 2:1) inhibition. Zones of inhibition above 15 mm are considered as having significant antimicrobial activity. A = Gas Sterilization; B = Gamma Radiation Sterilized 2-3 Mega Rad; C = Ethanol-dip sterilization.

- 8 -

FIG. 7 shows the effect of various sterilization methods on silicone sheathed antimicrobial/anticoagulant (minocycline/EDTA; 2:1) catheters. A = Gas Sterilization; B = Gamma Radiation Sterilized 2-3 Mega Rad; C = Ethanol-dip sterilized.

5 **FIG. 8** efficacy of silicone sheathed antimicrobial (minocycline/rifampin; 2:1) catheters.

FIG. 9 shows a comparison of the long-term efficacy of 3 silicone sheathed antimicrobials to Arrow and Cook + minocycline-coated catheters. minocycline/rifampin 2:1 obtained from pharmacy = --○--; minocycline/rifampin 2:1 in crystalline form produced in laboratory = --□--; minocycline/EDTA 2:1 = --●--; Arrow = --▲--; Cook + minocycline = --△--.

15 **FIG. 10** shows long-term efficacy of silicone sheathed antimicrobials (minocycline/rifampin; 2:1) implanted in human serum for 120 days. Data represents 24h zones of inhibition after each re-implantation. Pre-incubation baseline = open bar; Sample 1 = double cross-hatch; Sample 2 = cross-hatch.

20 **FIG. 11** shows a multi-lumen catheter that includes a single inner sheath (17) and a layer that includes a pharmacologically active agent or ingredient (18) and an outer sheath (19). The drawing depicts a catheter device having five lumens (20).

25 **FIG. 12** (residual antimicrobial activity) shows antimicrobial activity after catheter removal. The indicated numbers (13d, 6d, 21d, 30d, 42d) refer to the day, measured in days, after the catheter had been removed from the agar in an initial test for antimicrobial activity.

DETAILED DESCRIPTION OF THE PREFERRED EMBODIMENTS

The following examples are included to demonstrate preferred embodiments of the invention. It should be appreciated by those of skill in the art that the techniques
5 disclosed in the examples which follow represent techniques discovered by the inventor to function well in the practice of the invention, and thus can be considered to constitute preferred modes for its practice. However, those of skill in the art should, in light of the present disclosure, appreciate that many changes can be made in the specific
10 embodiments which are disclosed and still obtain a like or similar result without departing from the spirit and scope of the invention.

A. Indwelling Medical Devices

Medical devices according to the present invention include any such devices that
15 are indwelling in a patient or animal. Such devices include abdominal cavity drainage bags, connectors and tubing used by colostomy patients. Angioplasty devices also are included within the present invention. Preferred devices are catheters including introducing, sensing and monitoring catheters. More preferred are urinary, venous, arterial, and peritoneal tubes, tracheotomy devices, shunts and other medical devices or
20 prostheses.

With reference to FIG. 1 and FIG. 3, a catheter (1), according to one version of the present invention, comprises a catheter lumen (5) or (13) defining a hollow fluid passage through which fluids may be administered or withdrawn from the patient. The
25 catheter (1) being surrounded by a layer (3) or (10), of pharmacologically active agents. These pharmacologically active agent(s) or ingredient(s) may be in crystalline form or in powder form; or may impregnate a jacket of silicone or other pharmacologically active agent-permeable material. The layer (3) or (10) is, in turn, surrounded by a sheath (2) or (11). This sheath (2) or (11) is in some embodiments at least partially permeable to the
30 pharmacologically active agent(s). The permeability of the sheath (2) or (11) allows the

- 10 -

pharmacologically active agent(s) to diffuse out from the layer (3) or (10) and through the sheath (2) or (11) and eventually to surround the outer circumference of the catheter.

The catheter (1) may be any standard catheter which is currently available. It is
5 desirable that the catheter (1) be made of silicone or a like material that is at least semi-permeable when so desired for the pharmacological agent(s) in layer (3) or (10) to also diffuse into the lumen of the catheter (5) or (13).

In some embodiments, the sheath (2) or (11) is constructed from a material which
10 is at least partially permeable to the pharmacologically active agent(s) in layer (3) or (10). The material used and the thickness of the sheath (2) or (11) will determine how rapidly the pharmacologically active agent or ingredient will diffuse through the sheath (2) or (11) and into the surrounding environment. Thus, the selection of material for the sheath (2) or (11) will depend upon the particular application. Similarly, the choice of using an
15 embedded layer of pharmacologically active agent-permeable material (as in FIG. 3) or coating the lumen with pharmacologically active agent or ingredient (as in FIG. 1) will depend upon the particular application.

Referring to FIG. 4 and FIG. 5, the layer of pharmacologically active agent(s) (15)
20 and the sheath (16) may be coextensive with the underlying catheter (1) extending the entire length of the catheter as depicted in FIG. 5, or alternatively, may be limited to a portion of the catheter (1) which is in direct contact with the surrounding tissue, as depicted in FIG. 4.

25 An important alternative to using layer (3) in FIG. 1 is depicted in FIG. 2. In this embodiment, the catheter (1) is surrounded by a layer of pharmacologically active agent embedded in a silicone jacket (7), which in turn is surrounded by a silicone sheath (6). The catheter (1) and sheath (6) serve to sandwich the pharmacologically active agent (7) as an integral part of the catheter construction. As in the previous embodiment, the
30 concentration of the pharmacologically active agent, its density when embedded in the

- 11 -

silicone (7) and the thickness of the sheath (6) will determine the rate at which the pharmacologically active agent in the silicone jacket (7) will diffuse through the sheath (6) and surround the surface of the catheter. Thus, the selection of the sheath (6) material will vary depending on the specific application. Again, it is preferred for the inner sheath
5 surrounding the lumen of the catheter or the surface of the device to be made of silicone or similarly permeable or semi-permeable material if it is desirable for the pharmacological agents in the middle layer (7) to diffuse into the lumen (9) of the device.

In the previous embodiment, the layer of the pharmacologically active agent or
10 ingredient (15) and the sheath (16) may be coextensive with the catheter as depicted in FIG. 5 or may be limited in length to the area most directly in contact with the surrounding environment, such as a tissue, as depicted in FIG. 4. In some embodiments, the sheath and inner tube may also be embedded with at least one pharmacologically active agent or ingredient. For example, the sheath and inner tube may be constructed of
15 silicone embedded with a pharmacologically active agent or ingredient such as minocycline, or with a combination of pharmacologically active agent(s) or ingredient(s), such as minocycline/rifampin.

20 B. Pharmacologically Active Agent(s) or Ingredient(s)

Any pharmacologically active agent or ingredient may be used in preparing the devices of the present invention. Table 1 provides a representative list of antibiotics, anti-thrombotic drugs, anticoagulants, antifungal drugs, anti-viral agents, anti-inflammatory agents and other agents which may be used in the preparation of various embodiments of
25 the invention. Typical pharmacologically active agent(s) or ingredient(s) include anticoagulants, antifibrin agents, antiinflammatory agents and antimicrobials. Anticoagulants include EGTA, EDTA, heparin, urokinase, streptokinase, and others. Antiinflammatory agents include steroids, nonsteroidal antiinflammatory agents, and salicylates.

30

- 12 -

Antimicrobials include antibiotics, antifungal and antiviral agents. Antibiotics include minocycline, rifampin, penicillins, cephalosporins, monobactams, carbapenems, clindamycin, chloramphenicol, tetracycline, quinolones, macrolides, sulfa antibiotics, trimethoprim, fusidic acid and aminoglycosides. Antiviral agents include acyclovir, ganciclovir, fosiornet and pencyclovir. Antifungal agents include amphotericin B, azoles, flucytosine, cilofungin and nikkomyacin Z.

In certain applications, it will be sufficient to provide a single pharmacologically active agent or ingredient in the device. In other situations, it will be desirable to combine compatible ingredients. For example, it may prove useful to provide an antimicrobial agent along with an anticoagulant and/or an antiinflammatory agent. In another example, it may prove useful to provide multiple antimicrobial agents with differing target specificities, modes of action or duration together either alone or together with anticoagulants or antiinflammatory agents.

15

TABLE 1

	<u>ANTIBIOTICS</u>	<u>ANTI-FUNGAL DRUGS</u>
5	Aminoglycosides: <i>e.g.</i> gentamycin kanamycin streptomycin	Amphotericin B Azoles: <i>e.g.</i> Fluconazole Itraconazole Ketoconazole Miconazole
10	Cephalosporins: <i>e.g.</i> cefazolin Glycopeptides: <i>e.g.</i> vancomycin teicoplanin	Flucytosine Liposomal Amphotericin B Liposomal Nystatin Saperconazole
15	Monolides: <i>e.g.</i> erythromycin Penicillins: <i>e.g.</i> ampicillin carbenicillin penicillin	Cilofungin Nikkomyacin Z Pneumocandin Griseofulvin
20	nafcillin methicillin Quinolones: <i>e.g.</i> ciprofloxacin ofloxacin	<u>OTHERS</u>
25	Sulfa Drugs: <i>e.g.</i> sulfamethoxazole sulfonamide Tetracyclines doxycycline	Chloramphenicol Clindamycin Novobiocin Polymyxin Rifampin Rifabutin Trimethoprim Metronidazole Monobactams Carbapenems Beta lactomase inhibitors: <i>e.g.</i> clavulonic acid
30	minocycline	Fusidic acid Streptogramins Ethambutol Cyloserine Mupiricin Chlorhexidine Nalidixic acid Nitrofurantoin Aztreonam
	<u>ANTI-COAGULANT AND CHELATING DRUGS</u>	
35	Urokinase Heparin EDTA EGTA Streptokinase	
40		

TABLE 1 continued

	<u>ANTI-THROMBOTIC DRUGS</u>	<u>ANTI-VIRAL AGENTS</u>
5	Acetylsalicylic acid Indomethacin Dipyridamole Heparin Ibuprofen	Acyclovir Ganciclovir Fosiornet Pencyclovir
10	<u>ANTI-INFLAMMATORY AGENTS</u>	
	steroids nonsteroidal anti-inflammatory agents	
15	salicylates	

C. Sheath and Antimicrobial Jacket Materials

The composition and thickness of the sheath and, in certain embodiments the jacket, will help determine how rapidly the pharmacologically active agent or ingredient is released from its silicone matrix, through the sheath and for what period of time the pharmacologically active agent or ingredient will continue to be released. It is contemplated that the sheath will be from 0.1 to 3 millimeters in thickness, preferably 0.2mm to 0.4mm. The jacket will range from 0.1 to 3 millimeters in thickness, preferably about 1mm to about 2mm, and in other embodiments, about 1.59mm (actual size of jacket).

It is contemplated that the sheath will be from 0.1mm to 1.5mm in thickness, preferably 0.15mm to 0.25mm. The jacket will range from 0.1mm to 3.0mm in thickness, preferably 0.20mm to 0.30mm. The prototype catheter had a sheath that was prepared so as to have a thickness of about a 0.2mm thickness for the inner luminal layer, middle jacket layer, and sheath. The pharmacologically active agent(s) or ingredient(s) were contained in the middle jacket layer, either in crystalline or powder form or as silicone embedded with the agent(s) or ingredient(s). The luminal layer and sheath of the catheter of the invention may also be embedded or coated with pharmacologically active agent(s) or ingredient(s).

The sheath/jacket may, but need not be, made of the same material as the inner sheath that surrounds the catheter lumen. Suitable materials for the sheath and jacket include various silicone formulas. It has been found that polysiloxane rubber is useful in many applications. Polysiloxane materials are available commercially, and are known by the trade name SILASTIC (Dow Corning, Midland, MI; Baxter, McGaw Park, IL).

D. Diffusion Kinetics

The rate of release for the pharmacologically active agent or ingredient is inversely proportional to the duration of release. Depending on the clinical situation, the
5 desired amount of ingredient released per unit of time will vary, as will the desired duration of release. For example, where the likelihood of infection is high, a correspondingly high level of antimicrobial release may be desired. Similarly, if the device will be in contact with the patient for only a short period of time, a high rate of release (and short duration) is acceptable. In circumstances where the patient is sensitive to
10 higher levels of the pharmacologically active agent or ingredient, or where the device is in contact with the patient for an extended period of time, a lower release rate may be preferred.

One factor affecting duration of release is the initial concentration of
15 pharmacologically active agent or ingredient in the device. Typically, the higher the initial concentration of the pharmacologically active agent, the longer the duration of release of the agent will be. The release rate is affected by the thickness of the sheath and the density of the materials used to construct the antimicrobial jacket, as discussed above.

20 It is well within the skill of those in the field to alter release rates in a variety of different ways. For example, it is possible to produce a delayed release profile, where little or no pharmacologically active agent or ingredient is released initially, while allowing, after a predetermined period, substantial release of the included pharmacologically active agent or ingredient. It also is possible to obtain "burst" release profiles, where the
25 ingredient is delivered in concentrated bursts over an extended period. In still other embodiments, the device starts acting to release the pharmacologically active agent beginning at the time of insertion. Similarly, it is possible to produce stable, continuous levels of release over the same, extended periods.

Contemplated release periods range from one minute to weeks and even months. The appropriate levels of release for given pharmacologically active agent(s) or ingredient(s) may be determined by reference to standard medicinal formularies.

5 E. Preparation of an Antimicrobial-Containing Catheter

All of the compositions and methods disclosed and claimed herein can be made and executed without undue experimentation in light of the present disclosure. While the compositions and methods of this invention are described in terms of preferred
10 embodiments, it will be apparent to those of skill in the art that variations may be applied to the composition, methods and in the steps or in the sequence of steps of the method described herein without departing from the concept, spirit and scope of the invention. More specifically, it will be apparent that certain agents which are both chemically and physiologically related may be substituted for the agents described herein,
15 while the same or similar results would be achieved. All such similar substitutes and modifications apparent to those skilled in the art are deemed to be within the spirit, scope and concept of the invention as defined by the appended claims. The following examples are illustrative of the present invention but should not be considered, in any way, to be limiting.

20

EXAMPLE 1: CONSTRUCTION OF A "SANDWICH" CATHETER PROTOTYPE

Preparation of the Original Sheath Prototypes

The present example demonstrates the methods that were used in the preparation
25 of two prototypes of the sheath catheter.

These prototypes were constructed from 3 cm segments of silastic tubing. Two types were made. The first type was made with micronized pharmacologically active agents (crystalline powder) packed between two concentric silastic tubes. The second
30 type was made from micronized pharmacologically active agents compounded with clear

RTV sealant silicone, and embedded as a sandwich between a layer (sheath) and an inner luminal layer of clear RTV sealant silicone layers.

The first type is similar to the cross-section shown in FIG. 1.

5

The second type is similar to the cross-section shown in FIG. 2.

The silastic tubing used for preparing the prototypes was Medical Grade Tubing (Dow Corning Silastic[®] Brand, Cat No. 602-305). Other tubing used included a "Silicone Tubing" (Baxter, S/P[™] Medical Grade, Cat T5715; McGaw Park, IL). The sealant used in
10 preparing the devices was the 732[™] Multipurpose Sealant, a 100% silicone rubber (Dow Corning[®], Midland, MI). This material was used to seal the ends of the catheters as shown in FIG. 1. This silicone was also used to prepare the antimicrobial jacket layer (7) in FIG. 2, and was used to mold the sheath (6) and the lumen (8) layers of the catheter
15 structure.

PROTOTYPE I

Two different sizes of "Silastic" Brand (Dow Corning) tubes were used. The tube
20 sizes were:

tube 1 - (larger tube) 3.175 mm O.D./1.981 mm I.D.

tube 2 - (smaller tube) 1.7 mm O.D./0.8 mm I.D.

25 The sheath had a thickness of about 1.194mm (3.175-1.981 = 1.194). The jacket layer containing the pharmacologically active agent(s) or ingredient(s) had a thickness of about 0.28mm (1.981-1.7 = 0.281mm). The inner luminal layer had a thickness of about 0.9mm (1.7-0.8 = 0.9mm).

- 19 -

- Step 1: Tube 2 is slipped into tube 1. One end of the double tube was plugged with the silicone sealant, RTV 732 (Dow Corning, Midland, MI.).
- 5 Step 2: A pocket or layer was formed between tube 1 and 2. This space was packed with micronized pharmacologically active agent, such as minocycline, rifampin, minocycline/rifampin, minocycline/EDTA, EDTA, Fusidic acid, gentamycin, aztreonam, or minocycline/aztreonam.
- 10 Step 3: When the segment is filled with the pharmacologically active agent, the open end of the segment was sealed in the space between tubes 1 and 2.
- 15 Two types of sealants were used, these were:
1. silastic medical adhesive type A (Dow Corning, Cat No. 891); and
 2. RTV Sealant No. 732 (Dow Corning Corporation Medical Products - Midland, Michigan 48640)
- 20
- Several of these prototypes were produced using different pharmacologically active agents, for example, minocycline, rifampin, minocycline/rifampin, minocycline/EDTA, EDTA, Fusidic acid, gentamycin, aztreonam, and
- 25 minocycline/aztreonam.

PROTOTYPE 2

The second prototype produced is demonstrated in FIG. 2. The pharmacologically

30 active agent is compounded (embedded) in a silicone matrix. This combination of silicone

- 20 -

and pharmacologically active agent was used to provide a layer around the tube as described below. Also, the most preferred pharmacologically active agents used were minocycline/rifampin and minocycline.

5 This catheter was made in two different steps:

Step 1: A pharmacologically active agent-embedded silicone was fashioned like a jacket around the silastic tube.

10 Step 2: A silicone sheath was molded over the pharmacologically active agent-embedded jacket of step 1.

Each time a catheter was made, two different size teflon molds were used. One was used to fashion the jacket containing the pharmacologically active agent over the silastic
15 tube and a larger size mold was then used to construct the silicone sheath over the jacket embedded with the pharmacologically active agent.

The bores in the molds used to prepare the device were precisely drilled to specification, honed and polished in order to prevent the silicone from adhering to it.

20

Steps in Building Prototype II

Step 1. A small silastic tube (0.8 mm I.D./1.7 mm O.D.) was used as the central luminal portion of the catheter.

25

Step 2. A mold with bore size 2.77 mm was used most often to form the jacket layer of material containing the pharmacologically active agent(s) or ingredient(s) (*i.e.*, antimicrobial agents).

- 21 -

Step 3. Preparation of the pharmacologically active agent or ingredient embedded material: Micronized minocycline/rifampin (2:1) in a concentration of 120 mg minocycline and 60 mg rifampin per gram of RTV silicone 732 sealant were mixed thoroughly. This mixture was spread into the bore surfaces of both halves of the mold.

5

Step 4. The silastic tube in Step 1 (1.7 mm O.D.) was pressed and aligned central in the bore of the mold and both mold surfaces pressed together with a vice or clamp.

10

Step 5. After catalysis was complete (about 30 min.), the mold halves were pried apart and the catheter was released. The catheter now included a jacket of the pharmacologically active agent or ingredient bonded to the silastic tubing.

Step 6. Excess material was trimmed from the jacket surface.

15

Step 7. A mold with bore size 2.95 mm was used and either RTV silicone 732 or RTV silicone 732 embedded with pharmacologically active ingredient(s) was spread into the bore surfaces of both halves of the mold.

20

Step 8. The jacket of Step 5 embedded with the pharmacologically active ingredient(s) was centrally placed in the bore of the mold containing the RTV sealant, either alone or embedded with pharmacologically active agent(s) (prepared in Step 7), and the mold halves pressed together with a vice or clamp.

25

Step 9. After catalysis was complete (about 30 min.) the mold halves were pried apart and the completed catheter was released. The catheter now included a silicone sheath, or a sheath embedded with pharmacologically active ingredient(s), over the jacket containing the pharmacologically active ingredient(s).

Step 10. The excess material was trimmed from the catheter. The catheter was allowed to rest for several days to allow the catalytic products to dissipate before plating them. The outside diameter of the catheter was 2.95 mm. The outside sheath thickness was 0.18mm ($2.95 - 2.77 = 0.18$ mm).

5

The above diameter sizes do not represent preferred or even typical dimensions of the catheters of the present invention. Moreover, the particular dimensions of the above prototypes are not considered the ideal sizes for manufacturing dimensions. The sizes were selected as representative only of standard dimensions for the present studies, and particularly for the studies conducted in the following examples, using the device as diagramed in FIG. 2.

10

EXAMPLE 2: PROTOTYPE SYSTEM

The efficacy of the prototype catheter segment was established by determining its ability to inhibit microbial growth expressed as "zone of inhibition." The procedure involved sterilizing the catheters with ethylene oxide gas. *Staphylococcus epidermis* (SE-5667) was subcultured to a blood agar plate from frozen stock of SE-5667 (obtained from a patient with a blood strain infected with *S. epidermidis*).

15

20

Methods:

To 1000 ml of Mueller Hinton agar, 5 ml of a 0.5 McFarland turbidity standard was added when the agar became cool to the touch. A small amount of agar was poured into each dish and allowed to harden. The sterilized silicone catheter as prepared in Example 1, prototype 2, was placed in the center of the dish and a small amount of agar was poured over it to partially cover the catheter. The agar was allowed to harden, then another portion of agar was poured over the catheter in an amount enough to completely cover the device. The plate was then incubated for 24 h at 35°C. Twenty-four hours later, the zone of inhibition (mm) of the *S. epidermidis* was measured and recorded. In some studies, the zone of inhibition was measured daily and on day seven.

25

30

- 23 -

This 7-day period is referred to as one "cycle" of activity for purposes of describing the studies in the present invention.

On day seven, the catheter was removed from the original plate, wiped clean
5 with an alcohol prep, the alcohol allowed to evaporate. The catheter was then
reimplanted in a new agar plate prepared identically to the first cycle preparation above.
The new 24 h zone of inhibition after reimplantation was again recorded, and daily
measurements recorded thereafter. At the end of 14 days, the third cycle was started
and the zones of inhibition were continually recorded until the zone was "0" (*i.e.*, no
10 evidence of anti-microbial activity), or until the plate could no longer be read. A summary
of the method of use in determining the zone of inhibition is outlined in Table 2.

TABLE 2
DETERMINATION OF THE ZONE OF INHIBITION

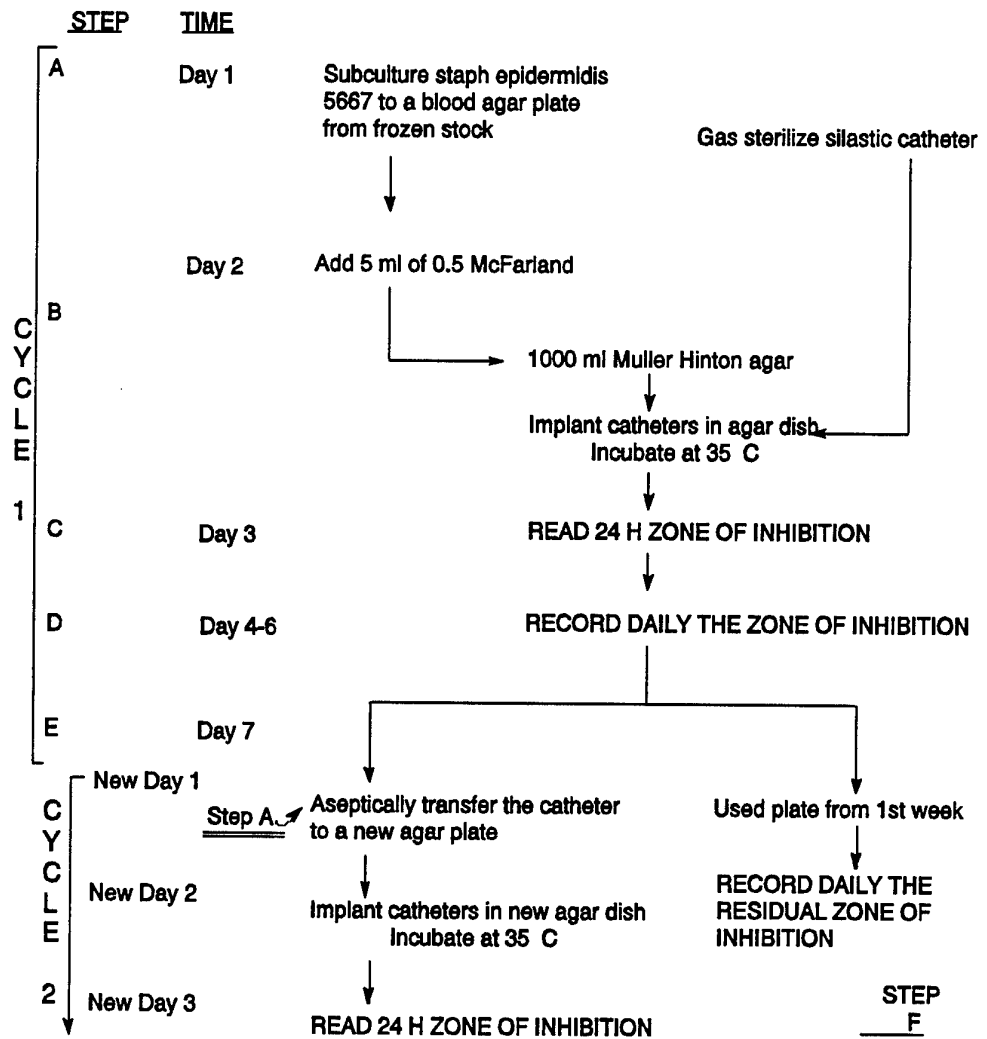

EXAMPLE 3: ANTIBIOTIC EFFECTS OF A "SANDWICH" CATHETER

The catheter used here is the same as FIG. 2 and prototype 2.

5 The present example demonstrates the anti-microbial activity observed with catheters that include the herein disclosed internal layer of pharmacologically active substances embedded in silicone and presented as a jacket sandwiched between two layers of silicone as demonstrated in FIG. 2.

Methods

10 *Staphylococcus epidermis* (SE) strain 5667 was subcultured to a blood agar plate (BAP) from a frozen stock as described in Example 2. Five to ten colonies of SE were subcloned into three 5 ml tubes and incubated for two hours. Three flasks of Mueller Hinton agar, 500 ml each, were prepared and autoclaved. After cooling, one of the 5 ml tubes was added to each of the Mueller Hinton agar flasks. The flasks were mixed
15 gently by swirling, and a small amount of the infected agar was poured into petri dishes, enough to cover the bottom of the plates. After cooling for about fifteen minutes, sections of catheter were placed on the agar and a small amount of agar was poured on top of the catheter, enough to submerge the entire catheter. After cooling for about fifteen minutes, the plates were placed at 37°C in an incubator for 24 hours. At seven
20 day intervals, the catheters were removed and replaced according to the protocol outlined in Example 2 and Table 2.

Results

25 The submerged segments diffused the antimicrobial content along the entire circumferential surface of the sheath. The zones of inhibition observed were significant and continued to be so after multiple replatings of the same catheter segments. For example, after four replatings (FIG. 8), a silicone sheathed catheter containing minocycline and rifampin powder or containing minocycline and rifampin embedded in silicone (FIG. 1 and FIG. 2), maintained a zone of inhibition of 35 mm. A zone of at least 15 mm has
30 been correlated with *in vivo* efficacy (Sherertz *et al.*). In contrast, an Arrow Gard

- 26 -

catheter coated with chlorhexidine gluconate and silver sulfadiazine, described in some clinical tests to reduce infection rates at least four-fold over untreated control (Maki *et al.*), lost essentially all antimicrobial activity, and had a zone of inhibition of zero after two replatings (FIG. 9).

5

EXAMPLE 4: CONSTRUCTION OF A TRILAYER CATHETER

The present example outlines the preparation of commercial embodiments of the invention. The 3 layers of the catheter will be extruded simultaneously, with all layers contributing to the catheter lining thickness and overall structural integrity. The various layers of these catheters are depicted in FIG. 2.

10

The two outermost layers, the sheath and middle antimicrobial jacket (FIG. 2: items 6,7), can be utilized in constructing any medical device or prosthesis to inhibit and/or prevent device-related infections. This is accomplished by bonding these layers to the surface of any device where such device is implanted and in contact with body fluids.

15

Methods

The catheter is to be extruded through a silicone extrusion machine, with the appropriate specialized tooling needed to force the antimicrobial components at a specified rate and thickness between the inner and outer silicone or other similarly permeable or semi-permeable layers of the device. This will produce a uniform internal "sandwiched" layer of the selected pharmacologically active agent or ingredient (*i.e.*, antimicrobial) throughout the device. The extrusion of the luminal tubes and the injection of the sheath is to occur in one single step. These three layers produce a sandwiched antimicrobial catheter (FIG. 2) with an interior lumen (9) surrounded by a silicone layer (8) and a middle jacket (7) and an exterior silicone sheath (6). The thicknesses of each layer is specified according to application and need.

20

25

- 27 -

After extrusion of the main body of the catheter, the "tubing" is to be cut at specified lengths and fitted with other standard structural components of an insertable device to form a usable unit prior to use. The "tubing" section is to be in some embodiments fitted with a silicone tip and a silicone-plastic manifold. Where multi
5 lumenal catheters are constructed (see FIG. 11), a multi-manifold unit is to be attached to the end of the pharmacologically active agent/silicone coated tube to form a completed catheter ready for use.

10 **Description and Materials Used to Construct Commercial Embodiments of the "Sandwich" Catheter.**

1. Silicone extrusion machines will be employed to extrude the catheter parts simultaneously as described herein.
- 15 2. Tooling devices that satisfy particular dimensional specifications for the desired catheter size will be used to manufacture the commercial products.
- 20 3. The pharmacologically active ingredient-embedded silicone, prepared with powder crystalline forms of the agent, will be extruded through tooling devices as described in (2) using the silicone extrusion machines in (1), to provide a catheter layer within the device that is co-extensive with all or at least some portion of the length of the device.
- 25 4. Extrusion manufacture of the catheter tubing with its several layers will occur simultaneously, with the inner lumenal layer, the middle "sandwiched" antimicrobial layer and the sheath layer being extruded at the same time.
5. The sandwich tubes in (4) above will then be cut into segments of desired lengths and fitted with a tip and a manifold part. The device will then be structurally

- 28 -

ready for use. The tube containing a sandwiched layer of antimicrobial is in some embodiments to be fitted with a tip made of silicone.

- 5 6. The tube in (5) is in some embodiments to be then fitted with a silicone manifold, the injection parts being in particular embodiments constructed out of standard plastic manifold materials.

Construction of a Trilayer Catheter

- 10 The tri-layer catheter embodies a design and concept similar to the sandwiched catheter described in Example 1 and the sandwich catheter described above.

15 **Layer 1** - The innermost layer may consist of a single tube (*i.e.*, single lumen) or multi-lumen tube with the limiting circumference preferably composed of silicone. In various other applications, the innermost layer may be any medical device or prosthesis requiring antimicrobial coatings to prevent device-related infections. The device may include impregnating or coating the innermost layer with pharmacologically active ingredient(s).

20 **Layer 2** - Layer 2 is the middle layer of the device, and comprises silicone and any variety of desired pharmacologically active agent(s) or ingredient(s). In one embodiment, the antimicrobial agents, are micronized and mixed homogeneously with the "A" and "B" components of the silicone preparation mixtures. The silicone mixture "A" and "B" are mixed together at extrusion, thus initiating the catalytic process that cures
25 the silicone and solidifies the device structure. This form of mixing of the antimicrobials with equal concentration in A and in B components of the silicone, renders a final product with uniform essentially equal concentrations of components A and B. This produces an accurate concentration of antimicrobial agent per gram silicone. A relatively high concentration of antimicrobial agents for use in the invention is about 180 milligrams
30 of antimicrobial/gram of silicone after extrusion. This concentration, of course, will vary

from 75%, 50% or even 25%. The selection of particular amounts of the antimicrobial or other active agent in the device will depend upon the design of the catheter or device and its particular intended use.

5 **Layer 3** - Layer 3 in some embodiments of the catheter constitutes the outermost layer or sheath encapsulating the antimicrobial layer described above. In some embodiments, this third layer is constructed of silicone. As already discussed, the thickness and the formulary type of silicone used to establish its density will determine in some embodiments the rate at which the antimicrobial agents in layer 2 diffuse out and
10 surround the circumference of the catheter or device. The variations in thickness and density of the silicone used for this layer are a matter of design choice, and will depend upon the intended use of the catheter or device. In some embodiments of the invention, the sheath may be embedded or coated with pharmacologically active ingredient(s).

15 Layers 1, 2, and 3 as described above are extruded simultaneously so as to form a single, solid integral unit with 3 inseparable layers. The second layer containing the antimicrobial agent(s) or other pharmacologically active agent(s) or ingredient(s) will occupy space and thus tend to increase the relative diameter of the catheter, and/or size of the device. Control of the overall diameter of the device is thus important to consider
20 in particular intended applications for the device, such as for use as vascular catheters where smaller total diameters are desired.

The solid integration of the second layer also adds support and strength to the walls of the catheter or device, thus permitting one to minimize the thicknesses of layers
25 1 and 3 to compensate for the added strength and thickness of layer 2. This also enables a reduction of the thicknesses of the whole catheter wall so as to produce a catheter that is sufficiently similar in size so as to provide a device comparable to standard devices/catheters that lack the second and third layers, enhancing the ready usability of the presently disclosed devices.

The extruded tube composed of the trilayer catheter is to be cut at specific lengths and fitted with other standard catheter components, readily available, to form a useable unit, as already discussed.

5

EXAMPLE 5: ANTIBIOTIC EFFECTS OF A TRILAYER CATHETER

The antibiotic effects of catheters made according to Example 3 were evaluated in assays as described in Example 2.

10

The results were similar to those reported above, with catheter segments retaining their antibiotic activity after as many as four replatings. In addition, the antibiotic activity was observed to persist in the cultures for up to ninety days after removal of the catheter, without recolonization from surrounding flora (FIG. 12).

15

This residual antimicrobial activity after catheter removal (Table 2, step F) was demonstrated in detail in FIG. 12. The antimicrobials used were minocycline/rifampin (2:1). After plating the catheters (as FIG. 2 and prototype 2) with silicone embedded antimicrobial jacket in agar (as per Table 2), the catheters were reimplanted after each 7-day cycle and the used plates, where the catheters used to be, were kept and observed (Table 2, step F) to determine whether the residual antimicrobial agents released when the catheter was implanted in the agar will still inhibit bacterial recolonization of the zone of inhibition in the absence of the catheter. FIG. 12 shows that the antimicrobial agents released from the catheter when present prevented recolonization of the zone of inhibition for up to 90+ days.

20
25

EXAMPLE 6: THE EFFECT OF VARIOUS STERILIZATION METHODS ON SILICONE SHEATHED ANTIMICROBIAL CATHETERS

The catheters were constructed as described in Example 1, prototype 2 (as shown in FIG. 2).

30

- 31 -

The 24 h zones of inhibition post-sterilization were recorded as shown in FIG. 6 for catheters containing minocycline/rifampin (2:1) and in FIG. 7 for catheters containing minocycline/EDTA (2:1).

5 The data indicates that no residual effects of sterilization affected the zones of inhibition. This is evidenced by the absence of any inhibition in the control samples. All the forms (gas sterilization, gamma radiation sterilized and ethanol-dip treatment) of sterilization used minocycline/rifampin (2:1) and minocycline/EDTA (2:1) did not alter the efficacy of the antimicrobial agents (catheter device FIG. 2 and prototype 2) or the
10 antimicrobial device tested.

**EXAMPLE 7: LONG TERM ANTIMICROBIAL EFFICACY
OF SILICONE-SHEATHED ANTIMICROBIAL CATHETER IN AGAR**

15 Antimicrobial catheters were prepared as demonstrated in the prototype of Example 1, prototype 2 (FIG. 2) using minocycline/rifampin (2:1) as the antimicrobial agents. The samples were embedded in agar plates inoculated with SE-5667 as outlined in Table 2. The samples were reimplanted weekly. The samples were challenged for 14 cycles (each cycle = about seven days).

20

The 24 h zones of inhibition were recorded as shown in FIG. 8. The means of the daily measurements from the 14 cycles are graphed in FIG. 9.

25 The silicone sheathed antimicrobial device maintained a significant antimicrobial activity, even though challenged repeatedly with reimplantation for 14 consecutive cycles. The residual antibiotic inhibitory activity of the 14 consecutive cycles persisted for at least 90 days after catheter reimplantation. Seven such residual activities are illustrated in FIG. 12.

These data demonstrate that *in vivo*, the efficacy of such catheters would be markedly more significant over their long term activity shown in FIG. 8 and FIG. 9, since they will not be challenged repeatedly but exert their action in one continuous period. *In vivo* (*i.e.* serum), the devices are expected to maintain a zone of inhibition around their circumference for a longer period of time than in the *in vitro* conditions (*i.e.* agar). This is supported by results obtained in serum culture, as demonstrated in Example 8 below. Furthermore, the long-term efficacy of the devices surpass the short-term antimicrobial activity of the Arrow and Cook + minocycline-coated catheters (FIG. 9).

EXAMPLE 8: LONG TERM ANTIMICROBIAL EFFICACY OF SILICONE SHEATHED ANTIMICROBIAL CATHETERS IN SERUM

Antimicrobial catheters were prepared as demonstrated in the prototype 2, FIG. 2 using minocycline/rifampin (2:1) as the antimicrobial agents. After sterilizing the samples with ethylene oxide, the catheters were individually submerged in serum, covered and incubated at 37°C for the specified time as described above. The samples were left incubating in the serum for 3, 7, 14, 28, 42, 56, 90 and 120 days. At each specified time the samples were removed from the serum and embedded in agar plates similar to the procedure outlined in Table 2 (step B).

The 24 h zones of inhibition were recorded as a measure of the efficacy of the catheters to control microbial growth. The results of this study are represented in FIG. 10. The study was carried out to 120 days, at which time the antimicrobial devices continued to demonstrate significant long-term antimicrobial activity. This activity was similar to the beginning baseline value.

REFERENCES

The following references, to the extent that they provide exemplary procedural or other details supplementary to those set forth herein, are specifically incorporated herein
5 by reference.

1. Durand, D.B., Shaw, JP., Bush, MR., Replogle, RE., Belagaje, R and Crabtree, GR, "Characterization of antigen receptor elements within the interleukin-2 enhancer," *Mol. Cell Biol.* **8**:1715 (1988).
10
2. Owaki, H., Varma, R., Gillis, B., Bruder, TT., Rapp, UR., Davis LS., and Geppert, TD, "Raf-1 is required for T cell IL-2 production," *EMBO J.* **12**:4367-4373 (1992).
- 15 3. Gorman, CM., Moffat, LF., and Howard, BH, "Recombinant genomes which express chloramphenicol acetyltransferase in mammalian cells," *Mol. Cell Biol.* **2**:1044 (1982).
4. Wepsic *et al.*, U.S. Patent No. 3,598,127.
20
5. Laurin *et al.*, U.S. Patent No. 4,677,143.
6. Raad *et al.*, U.S. Patent No. 5,362,754.
- 25 7. Raad *et al.*, U.S. Patent No. 5,324,275.
8. Raad *et al.*, U.S. Patent No. 5,217,493.
9. Sherertz *et al.*. "Efficacy of antibiotic-coated catheters in preventing subcutaneous
30 *Staphylococcus aureus* infection in rabbits," *J. Infect. Dis.* **167**:98-106, 1993.

- 34 -

10. Maki *et al.*, "Clinical trial of a novel antiseptic central venous catheter," abstr. 461, p. 176. Program abstr. 33rd Intersci. Conf. Antimicrob. Agents Chemother. American Society for Microbiology, Chicago, IL.

- 35 -

CLAIMS:

1. An indwelling medical construct comprising:
- 5 (i) an implantable medical device or a tube;
- (ii) a sheath surrounding part or all of the device or tube, the sheath
being concentric to and surrounding said device or tube; and
- (iii) at least one pharmacologically active agent
circumferentially located between said device or tube and said
sheath.
- 10
2. The construct of claim 1, wherein said pharmacologically active ingredient
is crystalline or powdered.
- 15
3. The construct of claim 1, wherein said pharmacologically active agent is
embedded in a jacket of pharmacologically active agent-permeable material located
between said device or tube and said outer sheath.
- 20
4. The construct of claim 3, wherein said pharmacologically active agent-
permeable material is silicone.
- 25
5. The construct of any of the preceding claims, wherein said
pharmacologically active agent is at least one of the compounds of Table 1.
- 30
6. The construct of claim 5, wherein said pharmacologically active agent is
EDTA, minocycline, or rifampin.

- 36 -

7. The construct of claim 6, wherein said pharmacologically active agent is minocycline.

5 8. The construct of claim 6, wherein said pharmacologically active agent is rifampin.

9. The construct of any of the preceding claims, comprising a combination of
10 pharmacologically active agents.

10. The construct of claim 9, wherein said combination of pharmacologically
active agents is selected from the group consisting of: an antimicrobial agent and an
15 anticoagulant; an antimicrobial agent and an antiinflammatory agent; and an antimicrobial
agent, an anticoagulant and an antiinflammatory agent.

11. The construct of claim 10, wherein said combination of pharmacologically
20 active agents is selected from the group consisting of minocycline/rifampin,
minocycline/EDTA, and minocycline/aztreonam.

12. The construct of claim 11, wherein said combination of pharmacologically
25 active agents comprises minocycline/rifampin.

13. The construct of any of the preceding claims, wherein said sheath is
permeable to said pharmacologically active agent.

30

- 37 -

14. The construct of any of the preceding claims, wherein said sheath is embedded with at least one pharmacologically active agent.

5 15. The construct of any preceding claim, wherein said device or tube is a tube.

10 16. The construct of claim 15, wherein said tube is a catheter.

17. The construct of claim 16, wherein said catheter is an urethral catheter.

15 18. The construct of claim 16, wherein said catheter is a venous or arterial catheter.

20 19. The construct of claim 16, wherein said sheath is substantially coextensive with said catheter so that it encases substantially the entire length of said catheter.

25 20. The construct of claim 16, wherein said sheath encases a portion of the length of said catheter.

30 21. The construct of any of claims 1-14, wherein said device or tube is an implantable medical device.

- 38 -

22. The construct of claim 21, wherein said implantable medical device is a shunt, peritoneal tube, tracheotomy device, abdominal cavity drainage bag, angioplasty device, an implantable medical prosthesis or a device adapted to be left implanted in the body for some length of time during use.

5

23. The construct of any of the preceding claims, wherein said device or tube is adapted to be slowly permeable to said pharmacologically active agent during use.

10

24. The construct of any of the preceding claims, wherein said device or tube is embedded with at least one pharmacologically active agent.

15

25. The construct of any of claims 1-22, wherein said device or tube is constructed from material which is impermeable to said pharmacologically active agent.

20

26. The use of the construct of any of the preceding claims to inhibit microbial colonization, comprising inserting said device into a patient.

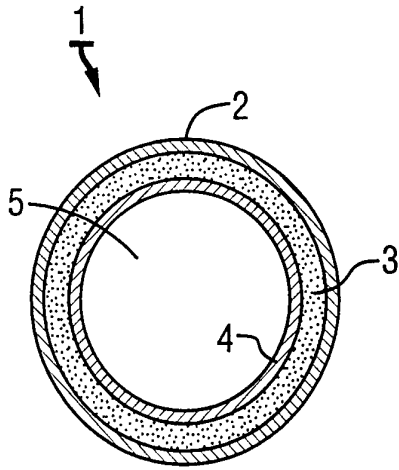

FIG. 1

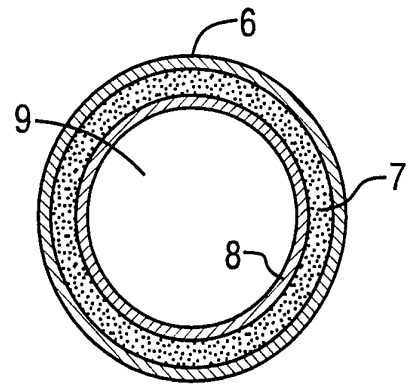

FIG. 2

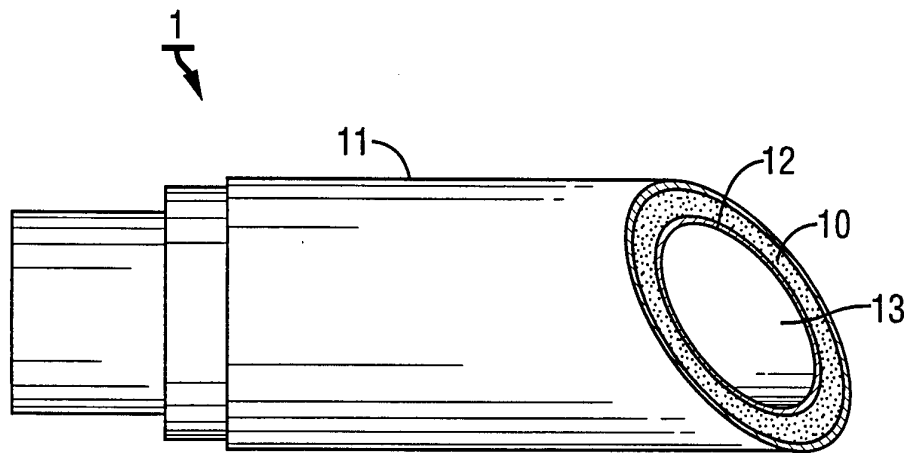

FIG. 3

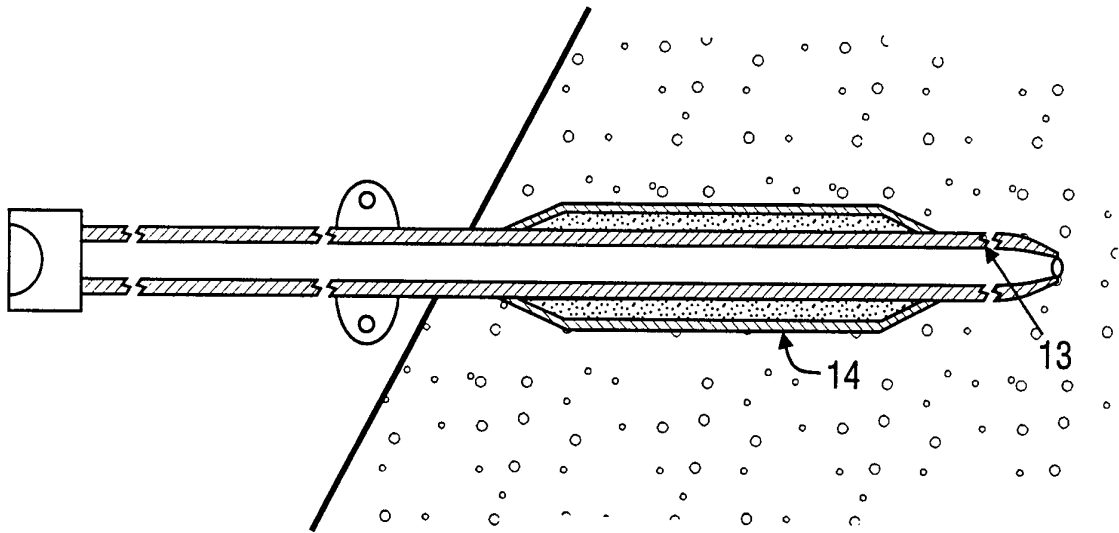

FIG. 4

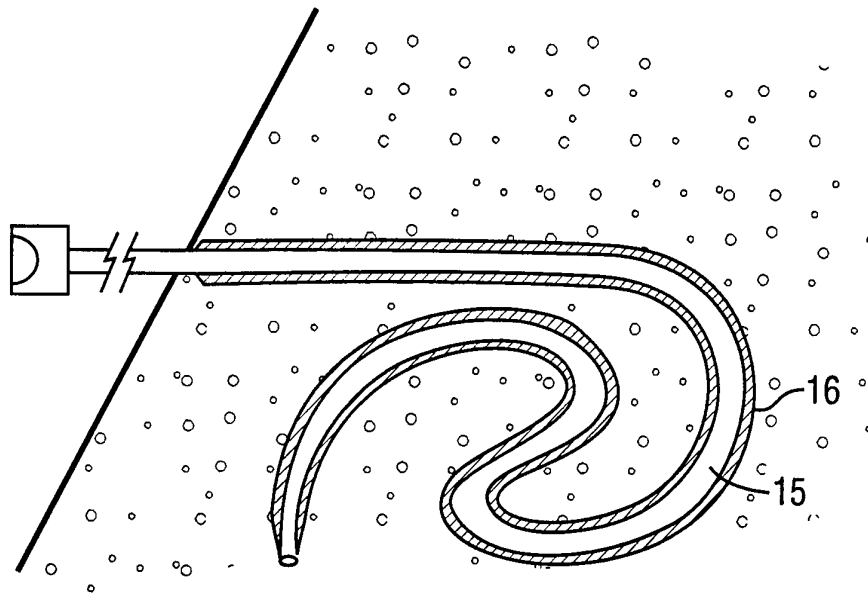

FIG. 5

3/6

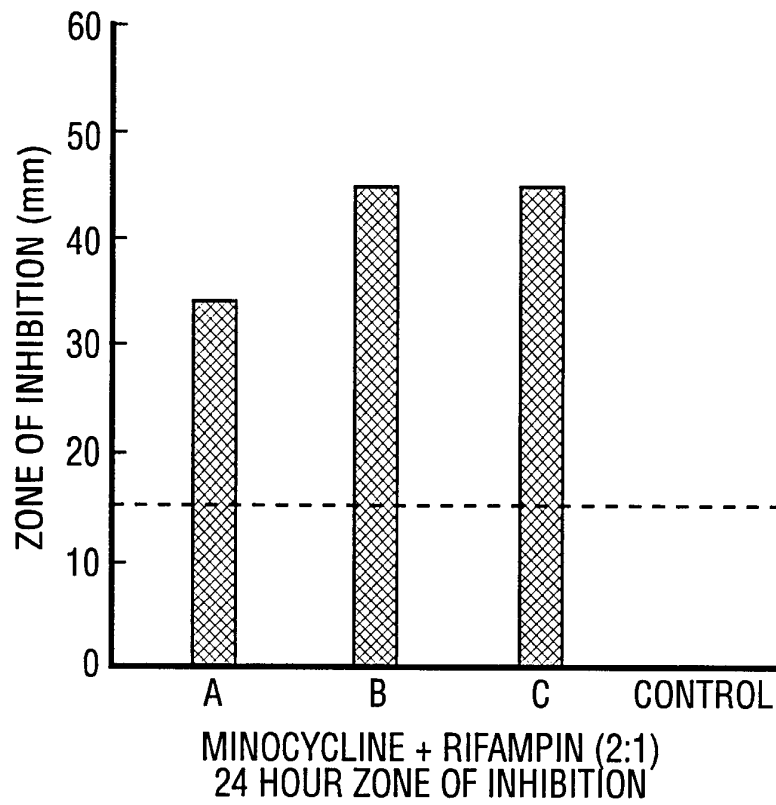

FIG. 6

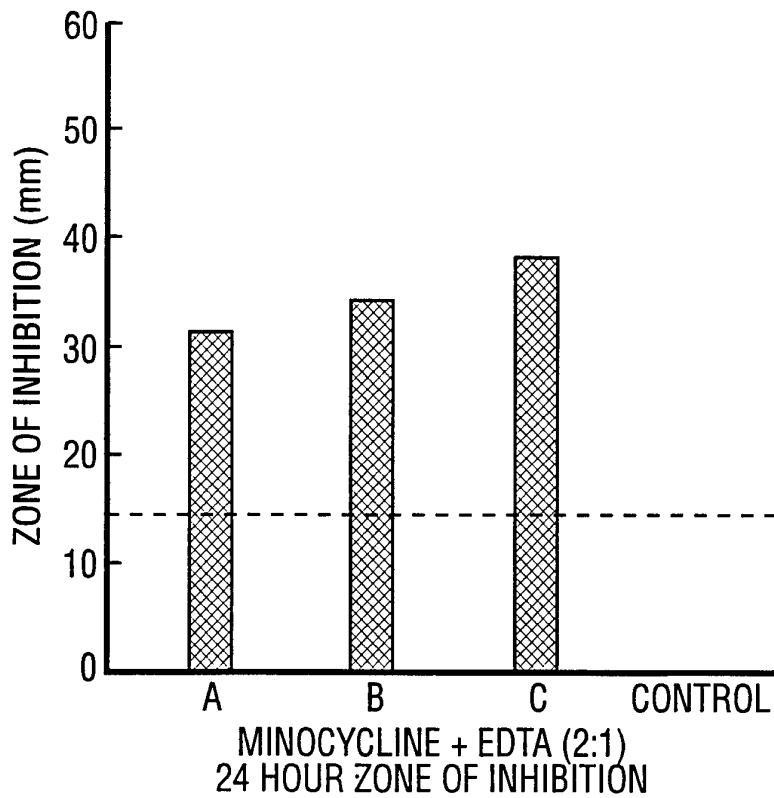

FIG. 7

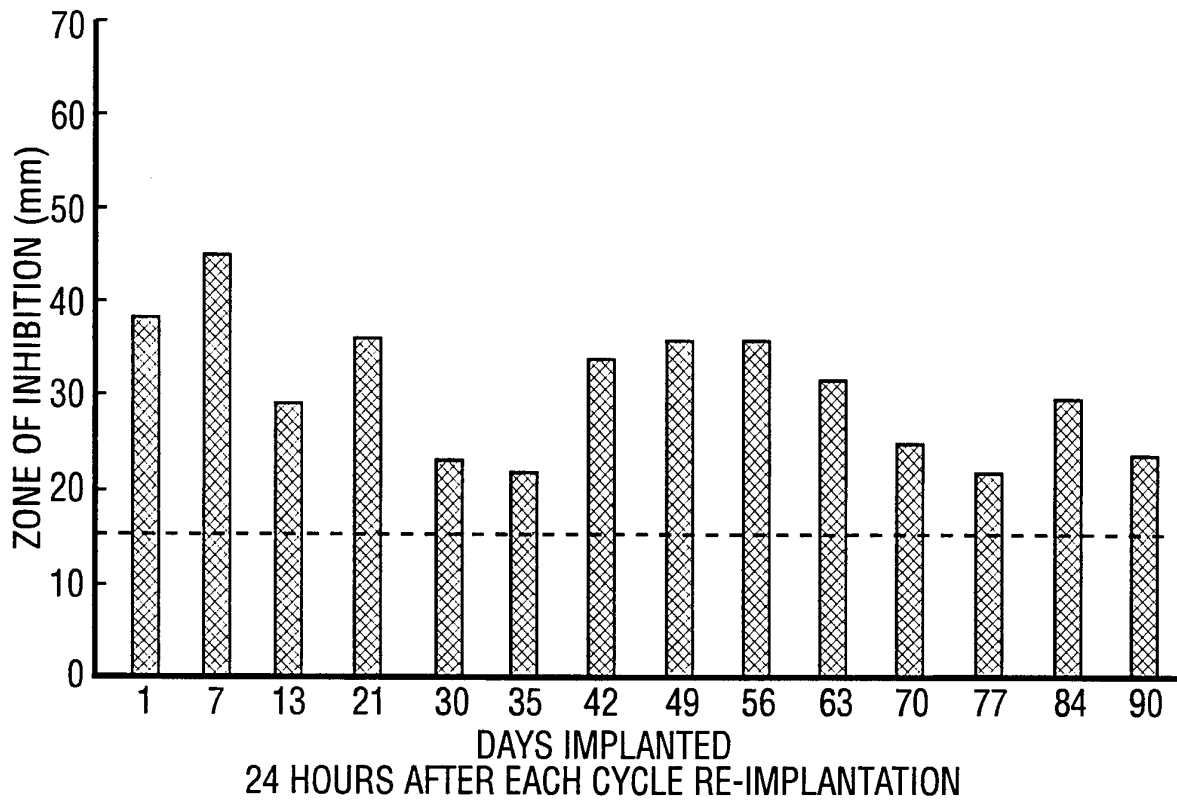

FIG. 8

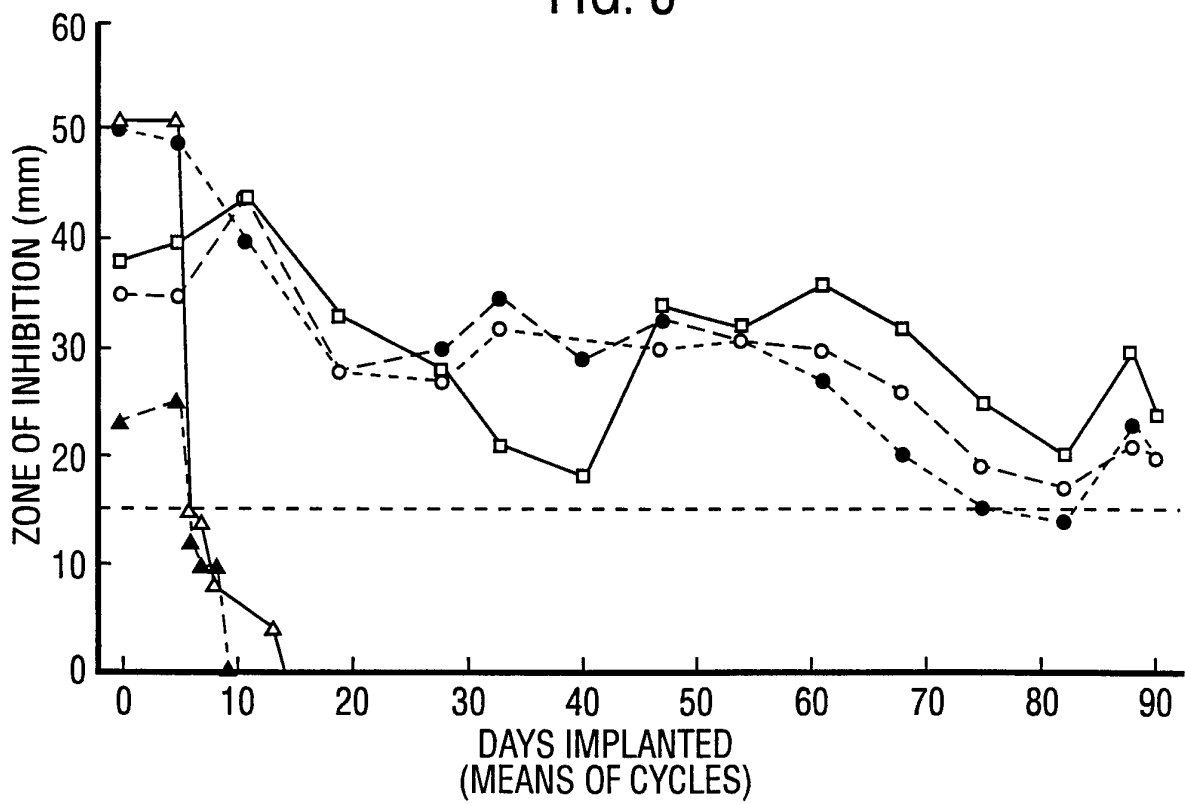

FIG. 9

5/6

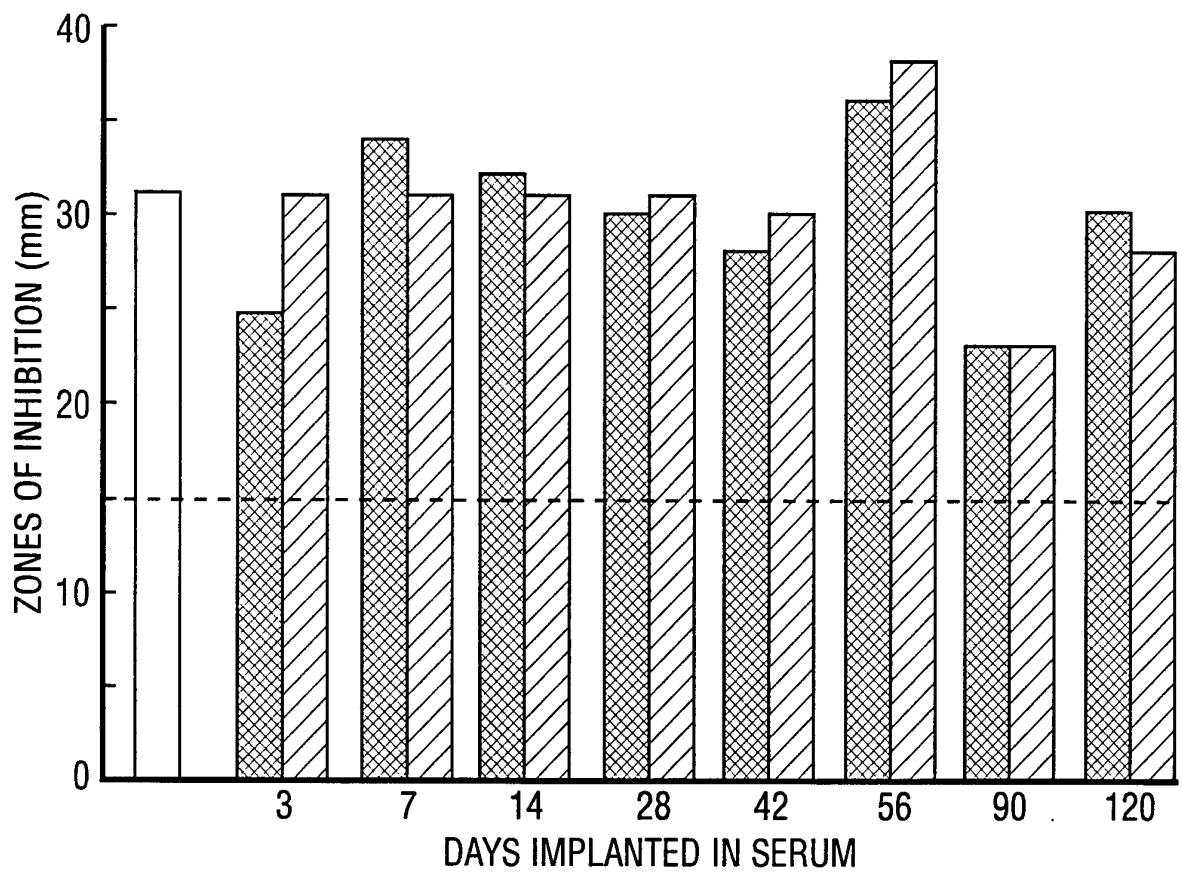

FIG. 10

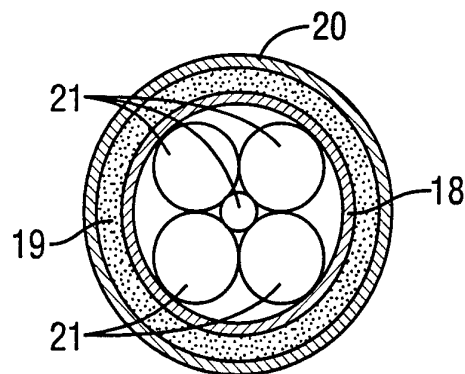

FIG. 11

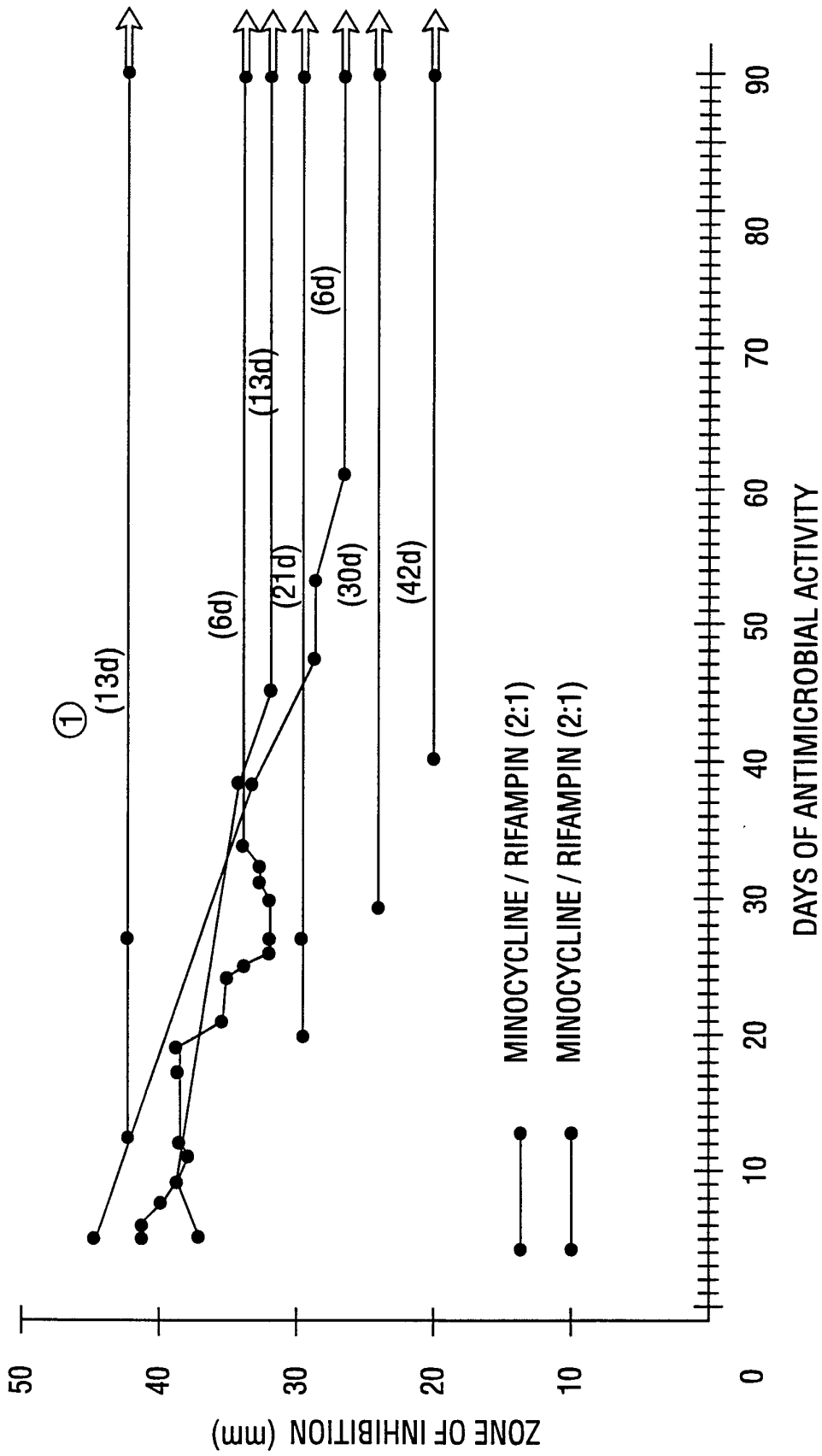

FIGURE 12

INTERNATIONAL SEARCH REPORT

International application No.
PCT/US96/09446

A. CLASSIFICATION OF SUBJECT MATTER

IPC(6) :A61M 5/32
US CL :604/265

According to International Patent Classification (IPC) or to both national classification and IPC

B. FIELDS SEARCHED

Minimum documentation searched (classification system followed by classification symbols)

U.S. : 604/265

Documentation searched other than minimum documentation to the extent that such documents are included in the fields searched

Electronic data base consulted during the international search (name of data base and, where practicable, search terms used)

C. DOCUMENTS CONSIDERED TO BE RELEVANT

Category*	Citation of document, with indication, where appropriate, of the relevant passages	Relevant to claim No.
X --- Y	US, A, 4,994,047 (WALKER ET AL.) 19 February 1991, see entire document.	1-5, 9, 10, 13-26 ----- 6-8, 11, 12

Further documents are listed in the continuation of Box C. See patent family annex.

* Special categories of cited documents:	"T" later document published after the international filing date or priority date and not in conflict with the application but cited to understand the principle or theory underlying the invention
"A" document defining the general state of the art which is not considered to be part of particular relevance	"X" document of particular relevance; the claimed invention cannot be considered novel or cannot be considered to involve an inventive step when the document is taken alone
"E" earlier document published on or after the international filing date	"Y" document of particular relevance; the claimed invention cannot be considered to involve an inventive step when the document is combined with one or more other such documents, such combination being obvious to a person skilled in the art
"L" document which may throw doubts on priority claim(s) or which is cited to establish the publication date of another citation or other special reason (as specified)	"&" document member of the same patent family
"O" document referring to an oral disclosure, use, exhibition or other means	
"P" document published prior to the international filing date but later than the priority date claimed	

Date of the actual completion of the international search

15 SEPTEMBER 1996

Date of mailing of the international search report

26 SEP 1996

Name and mailing address of the ISA/US
Commissioner of Patents and Trademarks
Box PCT
Washington, D.C. 20231

Facsimile No. (703) 305-3590

Authorized officer

Charles Robinson
MARK BOCKELMAN

Telephone No. (703) 308-2112