

W. SELLERS.  
RIVETING MACHINE.

No. 111,575.

Patented Feb. 7, 1871.

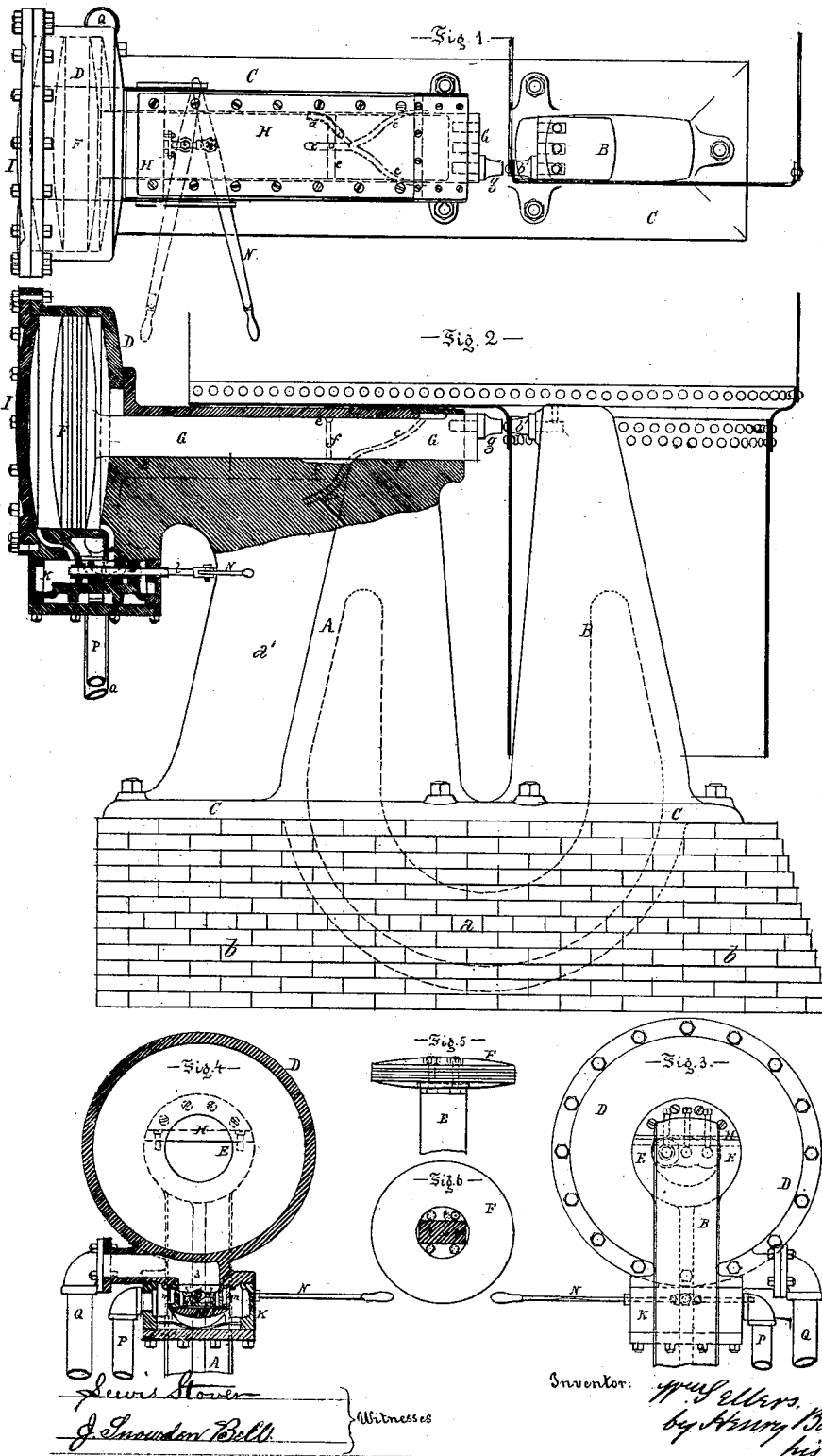

# UNITED STATES PATENT OFFICE.

WILLIAM SELLERS, OF PHILADELPHIA, PENNSYLVANIA.

## IMPROVEMENT IN RIVETING-MACHINES.

Specification forming part of Letters Patent No. 111,575, dated February 7, 1871.

*To all whom it may concern:*

Be it known that I, WILLIAM SELLERS, of the city and county of Philadelphia, in the State of Pennsylvania, have invented certain new and useful Improvements in Machines for Riveting Plate or Boiler Iron, of which the following is a specification, reference being had to the accompanying drawing, in which—

Figure 1 is a plan of a steam riveting-machine embodying my said improvements; Fig. 2, a side elevation and section through the center of the cylinder and valve-chest; Fig. 3, an end view of the cylinder and valve-chest; Fig. 4, a transverse section through the cylinder and valve-chest; Fig. 5, a plan of the piston and part of the piston-rod; and Fig. 6 an end view of the piston and a transverse section of a contemplated modification in the construction of a piston-rod, as hereinafter further set forth.

My invention relates to that class of riveting-machines in which, as heretofore constructed, the piston-rod is connected, as in ordinary steam-engines, to a head working in suitable guides, and the rivet-punch is attached to this head. Between the guides and the cylinder-head, and attached to the cylinder-head in these machines, is a suitable stuffing-box, to prevent the escape of steam. The punch is driven up by the direct action of the steam upon the piston.

In riveting certain classes of work—as, for example, in riveting the fire-box to the cylindrical part commonly called the “shell” of the locomotive-boiler—there must be provided, back of the end of the rivet-punch, an unobstructed space equal to the depth of the fire-box, below the shell of the boiler, in which space the fire-box must be turned around as each rivet is operated upon. Now, as the line of the rivets is but two inches from the flat side of the fire-box, this turning-space back of the punch must be measured upon a plane not exceeding two inches above the center of the punch; but in using a stuffing-box upon the piston-rod, the construction of these machines involves the necessity of exceeding this limit (two inches) above the center of the punch, so that to do the class of work above specified with these machines the cylinder must be removed farther from the rivet-punch by the length of the stuffing-box and follower than

when different classes of work are being done; and as this change in the machine for this work also involves cutting off the connection between the cylinder and the guides, independent supports must be provided for each.

It is the object of my invention to adapt the steam riveting-machines to all kinds of work, including the riveting of a fire-box to the shell of a locomotive-boiler, without changing the relation of the parts with the change from one class of work to the other, without cutting off the connection between the cylinder and the guides, and without using the independent supports for each, as heretofore has been requisite; and to this end my invention consists in connecting the guides and the steam-cylinder together, thereby forming a bearing of such length as will prevent the escape of steam, and thus dispense with the use of a stuffing-box; in supporting the cylinder by means of the connection of the guide to the post, so that the strain of the steam in the cylinder is transferred in a direct line to the post; in providing ducts to collect and carry off the water of condensation without allowing it to escape at the open end next the rivet-punch, and in an approved means of supporting the piston-rod, the punch, and the die.

In the accompanying drawing, the two main posts A B are formed in one piece with a base, *a*, shown in dotted lines in Fig. 2. To give to these posts increased strength with less metal, and to secure the machine more firmly, I provide them with a web or flange, C, forming a bed-plate, which rests upon the foundation *b* and is bolted thereto. The cylinder D is cast upon and united to the post A by a long semi-cylindrical-shaped trough or guide, E, stiffened by a web, *a'*, upon the post A. The rivet-die *b'* is mounted in or attached to the post B in the usual manner. Within the cylinder D is a piston, F, and within the trough or guide E is a semi-cylindrical piston-rod, G, one end of which is suitably secured to the piston. The piston may be packed in any of the ordinary ways to prevent the passage of the steam. I prefer to use for this purpose steel rings, having a square section fitting easily within corresponding recesses in the piston, the rings being of such diameter that, when cut apart and compressed within the cylinder, they will exert upon it sufficient

pressure to prevent the escape of steam. The rivet-punch *g* is secured in the forward end of the piston-rod *G* with due reference to its co-operation with the die *b'* in the post *B*.

It will be observed that I have provided three positions in the piston-rod for the punch and three corresponding positions in the post *B* for the die, (see Fig. 1,) so that the two parts between which the work is done may be placed as close together as is possible; but it is only intended to use one punch and one die at a time, placing them in their respective central positions for ordinary cylindrical or plain work and in their respective corresponding side positions for riveting the corners of fire-boxes or similar work.

My object in making the piston-rod *G* semi-cylindrical and flat on its upper surface is to reduce the distance from the center of the punch to the upper side of the piston-rod to the narrowest limits consistent with requisite stiffness, and this semi-cylindrical form is convenient to manufacture. I, however, contemplate using sometimes a rectangular piston-rod, as shown in Fig. 6, which will answer equally well. In either case, the trough or guide will correspond in form to the shape of the piston-rod, and will be covered in by a flat plate, *H*, secured on the trough by screws, and having a flange at the end next the cover of the cylinder, by which flange it is further secured to the cover. Within the trough which thus incloses it the piston-rod *G* plays freely toward and from the die in the post *B*, but this play must not be so free as to admit the flow through the trough of steam under any ordinary pressure. In so long a bearing it will be very easy to make such a steam-tight fit.

As the water of condensation is, however, liable to follow the piston and be discharged at the end next the punch, and as such discharge is objectionable, inasmuch as it would play upon the work and create a steam or vapor, which would prevent the workmen from managing it efficiently, I provide suitable ducts or channels *c c* in the sides and bottom

of the guide *E*, in which this water of condensation collects, and by which it is carried off by pipes *c'* to any point where its discharge may be least inconvenient.

I furthermore provide a channel or duct, *e*, extending across the upper surface of the piston-rod *G*, and a hole, *f*, directly through the piston-rod, so as to establish a communication between the channel *e* and the channels *c c*, that the water of condensation may also collect in the channel *e* and run off through the channels *c c*, as above described.

A cover, *I*, is secured to the flange of the cylinder *D* in the ordinary manner.

The means for operating this machine, which I propose to adopt, is a balanced valve, partially shown in the drawing, but the invention of Coleman Sellers, who has filed an application for Letters Patent therefor simultaneously with the filing of my application for this patent. As this forms no part of the invention herein claimed, I need only refer to said Coleman Sellers' application for the particulars of this part of the machine.

What I claim as my invention, and desire to secure by Letters Patent, is—

1. In a steam riveting-machine, the continuous closed guide attached to and opening into the cylinder, and extending from the cylinder to the post *A*, and covered in by a flat plate, *H*, substantially as and for the purposes described.

2. The combination of the cylinder, the continuous closed guide connected therewith, the semi-cylindrical or rectangular piston-rod, and the supporting-post, substantially as described.

3. The ducts in the piston and guide, operating as described, for the purposes set forth.

4. The construction and relative arrangement of the post *A*, supporting the punch, the guide, the cylinder, and the piston, and the post *B*, holding the die, as described.

WM. SELLERS.

Witnesses:

DAVID L. LUKENS,  
THOS. A. SMITH.