

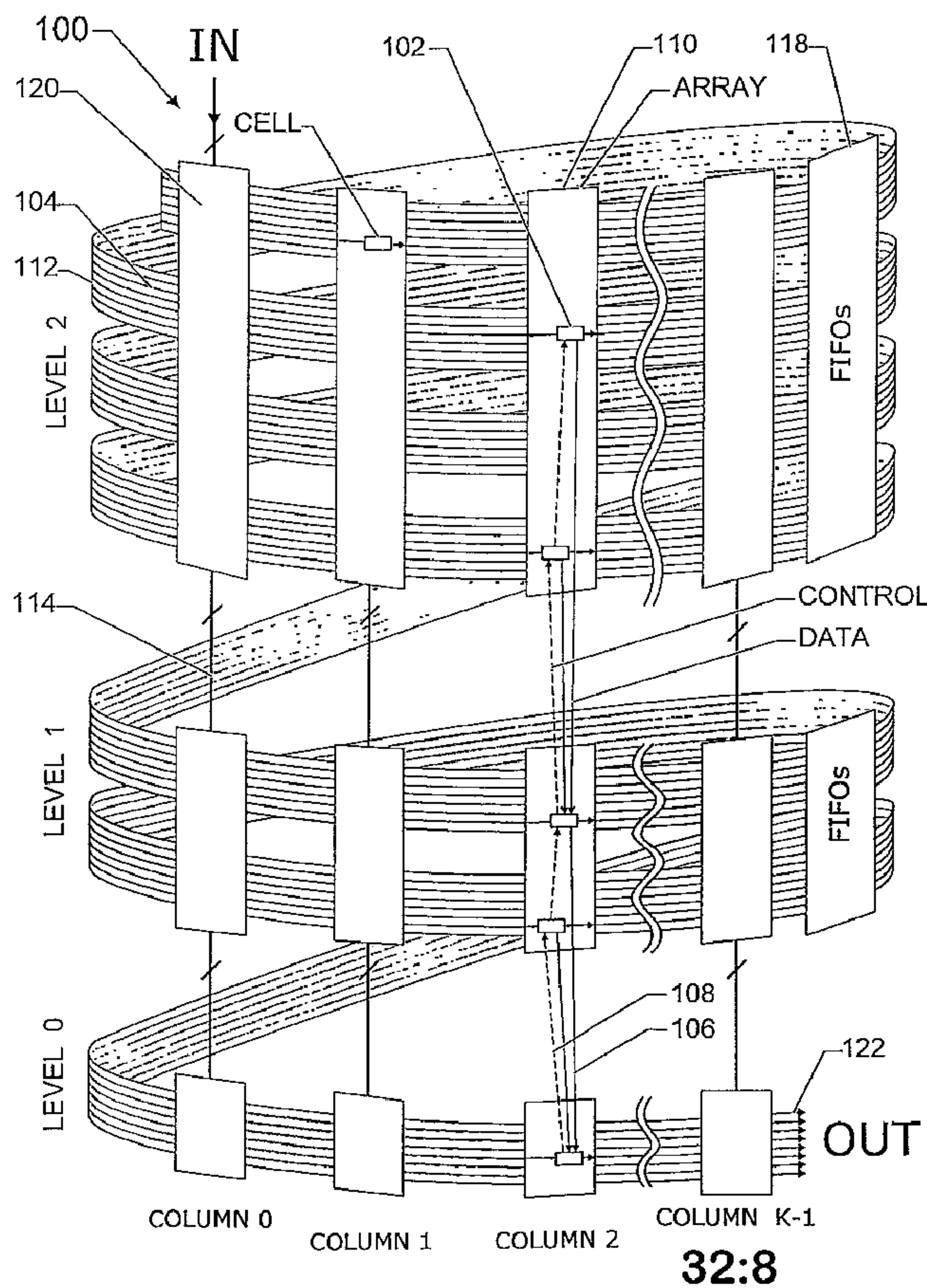

(86) Date de dépôt PCT/PCT Filing Date: 2001/10/19
 (87) Date publication PCT/PCT Publication Date: 2002/04/25
 (45) Date de délivrance/Issue Date: 2010/09/21
 (85) Entrée phase nationale/National Entry: 2003/04/22
 (86) N° demande PCT/PCT Application No.: US 2001/050544
 (87) N° publication PCT/PCT Publication No.: 2002/034004
 (30) Priorité/Priority: 2000/10/19 (US09/693,357)

(51) Cl.Int./Int.Cl. *H04Q 11/04* (2006.01),
H04Q 3/68 (2006.01)
 (72) Inventeurs/Inventors:
REED, COKE S., US;
HESSE, JOHN E., US
 (73) Propriétaire/Owner:
INTERACTIC HOLDINGS, LLC, US
 (74) Agent: SMART & BIGGAR

(54) Titre : CONCENTRATEUR DE ROUTAGE WORMHOLE ADAPTABLE
 (54) Title: SCALEABLE WORMHOLE-ROUTING CONCENTRATOR



(57) Abrégé/Abstract:

An interconnect structure (100) substantially improves operation of an information concentrator (700) through usage of single-bit routing through control cells using a control signal. The interconnect structure and operating technique support wormhole routing

(57) **Abrégé(suite)/Abstract(continued):**

and flow of messages. Message packets are always buffered within the structure and never discarded, so that any packet that enters the structure is guaranteed to exit. In one example, the interconnect structure includes a ribbon of interconnect lines connecting a plurality of nodes in nonintersecting paths. The ribbon (112) of interconnect lines winds through a plurality of levels from the source level to the destination level. The number of turns of a winding decreases from the source level to the destination level. The interconnect structure further includes a plurality of columns formed by interconnect lines coupling the nodes across the ribbon in cross-section through the windings of the levels.

(12) INTERNATIONAL APPLICATION PUBLISHED UNDER THE PATENT COOPERATION TREATY (PCT)

(19) World Intellectual Property Organization
International Bureau(43) International Publication Date
25 April 2002 (25.04.2002)

PCT

(10) International Publication Number
WO 02/034004 A3

- (51) International Patent Classification⁷: H04Q 11/04, 3/68
- (74) Agents: KOESTNER, Ken, J. et al.; Koestner Bertani LLP, 1924 Galaxy Drive, Newport Beach, CA 92660 (US).
- (21) International Application Number: PCT/US01/50544
- (81) Designated States (*national*): AE, AG, AL, AM, AT, AU, AZ, BA, BB, BG, BR, BY, BZ, CA, CH, CN, CO, CR, CU, CZ, DE, DK, DM, DZ, EC, EE, ES, FI, GB, GD, GE, GH, GM, HR, HU, ID, IL, IN, IS, JP, KE, KG, KP, KR, KZ, LC, LK, LR, LS, LT, LU, LV, MA, MD, MG, MK, MN, MW, MX, MZ, NO, NZ, PH, PL, PT, RO, RU, SD, SE, SG, SI, SK, SL, TJ, TM, TR, TT, TZ, UA, UG, UZ, VN, YU, ZA, ZW.
- (22) International Filing Date: 19 October 2001 (19.10.2001)
- (25) Filing Language: English
- (26) Publication Language: English
- (30) Priority Data:
09/693,357 19 October 2000 (19.10.2000) US
- (84) Designated States (*regional*): ARIPO patent (GH, GM, KE, LS, MW, MZ, SD, SL, SZ, TZ, UG, ZW), Eurasian patent (AM, AZ, BY, KG, KZ, MD, RU, TJ, TM), European patent (AT, BE, CH, CY, DE, DK, ES, FI, FR, GB, GR, IE, IT, LU, MC, NL, PT, SE, TR), OAPI patent (BF, BJ, CF, CG, CI, CM, GA, GN, GQ, GW, ML, MR, NE, SN, TD, TG).
- (71) Applicant: INTERACTIC HOLDINGS, LLC [US/US]; 62 William Street, Princeton, NJ 08540 (US).
- (72) Inventors: REED, Coke, S.; 62 William Street, Princeton, NJ 08540 (US). HESS, John; 827 Stetson Street, Moss Beack, CA 94038 (US).

[Continued on next page]

(54) Title: SCALEABLE WORMHOLE-ROUTING CONCENTRATOR

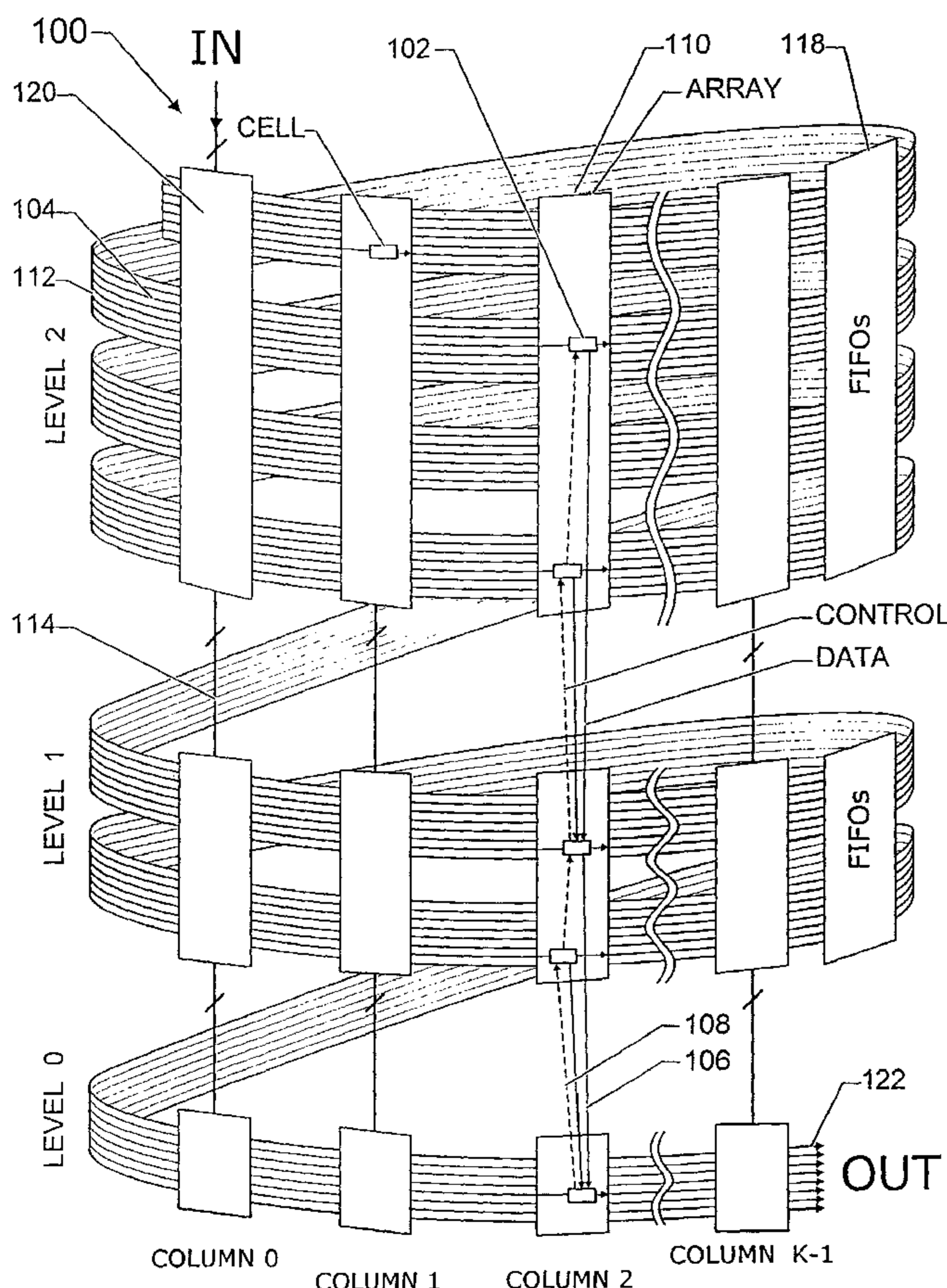

(57) Abstract: An interconnect structure (100) substantially improves operation of an information concentrator (700) through usage of single-bit routing through control cells using a control signal. The interconnect structure and operating technique support wormhole routing and flow of messages. Message packets are always buffered within the structure and never discarded, so that any packet that enters the structure is guaranteed to exit. In one example, the interconnect structure includes a ribbon of interconnect lines connecting a plurality of nodes in nonintersecting paths. The ribbon (112) of interconnect lines winds through a plurality of levels from the source level to the destination level. The number of turns of a winding decreases from the source level to the destination level. The interconnect structure further includes a plurality of columns formed by interconnect lines coupling the nodes across the ribbon in cross-section through the windings of the levels.

 WO 02/034004 A3

WO 02/034004 A3



Published:

— *with international search report*

(88) Date of publication of the international search report:

13 March 2003

For two-letter codes and other abbreviations, refer to the "Guidance Notes on Codes and Abbreviations" appearing at the beginning of each regular issue of the PCT Gazette.

5 **BACKGROUND OF THE INVENTION**

A communication or computing network is composed of several or many devices that are physically connected through a communication medium, for example a metal or fiber optic cable. One type of device that can be included in a network is a concentrator. For example, a large-scale time-division switching network may include a central switching network and a series of
 10 concentrators that are connected to input and output terminals of other devices in the switching network.

Concentrators are typically used to support multiport connectivity to a network. A concentrator is a device that is connected to a plurality of shared communications lines that concentrates information onto fewer lines. Concentrators inherently reduce the capacity of an
 15 interconnect path by increasing the occurrence of blocking and data loss, or by calling for storage of information in buffers.

A persistent problem that arises in massively parallel computing and in communications occurs when moving the data to the processors and users. This problem is exacerbated in systems that incorporate concentrators due to the inherent reduction in capacity.

20 What is needed is a concentrator structure that rapidly routes data and improves information flow by avoiding blockages, that is scaleable virtually without limit, and that supports low latency and high throughput.

SUMMARY OF THE INVENTION

25 An interconnect structure substantially improves operation of an information concentrator through usage of single-bit routing through control cells using a control signal. The terms "cell" or "control cell" refer to a simple switching element. The term "node" refers to a cell or group of cells that operate as a unit. The interconnect structure and operating technique support wormhole routing and flow of messages. Message packets entering the structure are
 30 never discarded, so that any packet that enters the structure is guaranteed to exit.

In accordance with one aspect of the present invention, an interconnect structure includes a ribbon of interconnect lines connecting a plurality of nodes in nonintersecting paths. The ribbon of interconnect lines winds through a plurality of levels from the source level to the destination level. The number of turns of a winding decreases from the source level to the
 35 destination level. The interconnect structure further includes a plurality of columns formed by interconnect lines coupling the nodes across the ribbon in cross-section through the windings of the levels. A method of communicating data over the interconnect structure incorporates a high-speed minimum logic method for routing data packets down multiple hierarchical levels.

In accordance with another aspect of the invention there is provided an interconnect
 40 structure. The structure includes a set S of parallel data paths such that data in a packet form can

5 enter the data paths from one or more devices external to the interconnect structure and travel in wormhole transmission on one or more data paths of the set S to a data output port. At a node A on a data path P of set S, data moves from the node A to a node B that is an immediate successor to the node A on the data path P so that the data movement from the node A to the node B moves is a one step movement closer to the data path P data output port. Alternatively, based on
10 precedence of data traveling through the interconnect structure data moves from the node A to a node C on a data path Q of the set S the data changes from movement on the data path P to movement on the data path Q, the node C being closer to the data path Q data output port than the node B is to the data path P data output port.

The interconnect structure may include a node D on the data path Q that may be an
15 immediate predecessor to the node C data traveling from the node D to the node C may have precedence over data traveling from the node A to the node C.

The interconnect structure may handle high traffic conditions without discarding data. A data packet may move through the interconnect structure independent of target output information contained in the data packet.

20 The data path Q may be separate and distinct from the data path P.

The data path Q and the data path P may be the same data path.

In accordance with another aspect of the invention there is provided an interconnect structure. The structure includes a plurality of transmission rings, a plurality of nodes arranged in the plurality of data transmission rings, the data transmission rings being arranged in a
25 plurality of levels from a highest level L to a lowest level 0. The data transmission rings includes a plurality of windings and the number of data transmission rings in a winding decreases from the highest level L to the lowest level 0. Rings on level L have one or more nodes capable of receiving data from outside the interconnect structure. The plurality of nodes include nodes A, B, C, X, and Y, the node B being on a level J between level 0 and level L, the
30 node A being an immediate predecessor to the node B on the same data transmission ring as the node B, the node C being an immediate follower to the node B on the same data transmission ring as the node B, the node X being on a level K greater than the level J, and the node Y being on a level P smaller than the level J. , the node B is capable of receiving data from the node A and the node X, and the node B is capable of sending data to the node C and the node Y, the data
35 being self-routed using no header information identifying a target for a data message.

The data may be self-routed at least in part based on quality of service information included in the header.

In accordance with another aspect of the invention there is provided an interconnect structure. The structure includes a plurality of data transmission lines, and a plurality of nodes
40 arranged on the plurality of data transmission lines. The plurality of data transmission lines are

5 arranged in a plurality of windings and the number of data transmission lines in a winding
 decreases from input to output of the interconnect structure. The plurality of nodes include a
 node B and a subset S of nodes, the node subset S including one or more nodes capable of
 sending data to the node B, the nodes in the subset S having a priority relationship for sending a
 message to the node B so that for a node N in the subset S and a message M arriving at the node
 10 N then the node N is never blocked from sending the message M to node B by a message from a
 node in the subset S with lower priority than the node N for sending a message to the node B, the
 plurality of nodes being capable of routing the message M in the absence of routing information
 for the message M.

The interconnect structure may include a node subset TN being a subset of nodes to
 15 which the node N may be capable of routing messages, and a logic associated with the node N
 that ranks members of the subset TN from a node most desirable to receive the message M to a
 node least desirable to receive the message M, the logic associated with the node N sending the
 message M to the most desirable unblocked member of the subset TN.

The interconnect structure may include a node A that may be an immediate predecessor
 20 to the B, the node A having the highest priority to send a message to the node B.

In accordance with another aspect of the invention there is provided an interconnect
 structure. The structure includes a plurality of nodes arranged in a structure including a
 hierarchy of levels from a source level to a destination level, and a plurality of nodes in
 nonintersecting paths extending along the levels, and a plurality of nodes in a cross-section of
 25 the nonintersecting paths of the levels. The number of nodes in a cross-section of the source
 level is greater than the number of nodes in a cross-section of the destination level so that the
 interconnect structure is a concentrator, the level of a node being determined entirely by the
 position of the node in the structure. The structure also includes a plurality of interconnect lines
 coupling the nodes in the structure including for a node N on a pathway P of a level L, a
 30 message input interconnect line coupled to a first adjacent node on the pathway P of the level L,
 a message output interconnect line coupled to a second adjacent node on the pathway P of the
 level L, at least one message interconnect line coupled to one or more nodes toward the source
 with respect to the node N for receiving data from a node toward the source in the hierarchy,
 and/or coupled to one or more nodes toward the destination with respect to the node N for
 35 sending messages from a node toward the destination in the hierarchy, and at least one control
 interconnect line coupled to a node toward the source with respect to the node N for sending a
 control signal to the node toward the source, and/or coupled to a node toward the destination
 with respect to the node N for receiving a control signal from the toward the destination node.

The interconnect structure may include a logic associated with the node N that may be
 40 capable of determining whether the node N is occupied by a message on the pathway P of the

5 level L and on the basis of the determination sending a control signal to the node toward the source, speeding advancement of a message at the node toward the source.

The interconnect structure may include a plurality of columns, each column interconnecting a plurality of nodes in a cross-section of the nonintersecting paths in a level, the columns including the interconnections between nodes including toward the source and toward
10 the destination couplings on the at least one message interconnect lines and on the at least one control interconnect lines.

The interconnect structure may include a plurality of FIFO buffers coupled to the respective nonintersecting paths extending along the levels.

The plurality of interconnect lines coupling the nodes in the structure including for the
15 node N on a pathway P of a level L may further include a first control output interconnect line coupled to a node toward the source with respect to the pathway P and in the level L, and a second control output interconnect line coupled to a node in a level toward the source with respect to the level L.

The plurality of interconnect lines coupling the nodes in the structure including for the
20 node N on a pathway P of a level L may further include a first message input interconnect line coupled to a node toward the source with respect to the pathway P and in the level L, a second message input interconnect line coupled to a node in a level toward the source with respect to the level L, and a control output interconnect line coupled to a node toward the source with respect to the pathway P and in the level L.

The plurality of interconnect lines coupling the nodes in the structure including for the
25 node N on a pathway P of a level L may further include a first control output interconnect line coupled to a node toward the source with respect to the pathway P and in the level L, a second control output interconnect line coupled to a node in a level toward the source with respect to the level L, and a message input interconnect line coupled to a node toward the source with respect
30 to the pathway P.

The interconnect structure may include priority nodes among the plurality of nodes, other nodes being nonpriority nodes, the priority nodes and the nonpriority nodes being selectively interconnected.

The interconnect structure may include a logic that interconnects nodes into groups to
35 concentrate n nodes on a path toward the source to m nodes on a path toward the destination, n being greater than m and n:m being a concentration ratio.

The interconnect structure may include a ribbon of interconnect lines connecting a plurality of nodes in the nonintersecting paths, the ribbon of interconnect lines winding through the levels from the source level to the destination level, the number of turns of a winding

5 decreasing from the source level to the destination level, and a plurality of columns coupling the nodes in cross-section of the ribbon through all windings of the levels.

The number of windings of the interconnect line ribbon may be reduced by one-half for each level from the source level to the destination level.

10 In accordance with another aspect of the invention there is provided a system. The system includes a plurality of switches, and a plurality of concentrators coupled respectively to the plurality of switches, the concentrators being as defined above.

15 In accordance with another aspect of the invention there is provided an interconnect structure. The structure includes a ribbon of interconnect lines connecting a plurality of nodes in nonintersecting paths, the ribbon of interconnect lines winding through a plurality of levels from the source level to the destination level, the number of turns of a winding decreasing from the source level to the destination level. The structure also includes a plurality of columns formed by interconnect lines coupling the nodes across the ribbon in cross-section through the windings of the levels.

20 The interconnect structure may include a plurality of input ports coupled to the nodes in a first column of the source level.

The interconnect structure may include a plurality of output ports coupled to the nodes in a last column of the destination level.

The interconnect structure may include a plurality of FIFO buffers coupled to the respective nonintersecting paths extending along the levels.

25 The interconnect structure may include the number of windings of the interconnect line ribbon may be reduced by one-half for each level from the source level to the destination level.

The interconnect structure may include control lines extending from nodes inside the interconnect structure to one or more devices outside the interconnect structure to control entry of messages into the interconnect structure.

30 The interconnect structure may include a logic that interconnects nodes into groups to concentrate n nodes on a path toward the source to m nodes on a path toward the destination, n being greater than m and $n:m$ being a concentration ratio.

35 The interconnect structure may include a logic that may be capable of determining whether a node is occupied by a message on the path of a level and on the basis of the determination sending a control signal to a node toward the source, speeding advancement of a message at the node toward the source.

The interconnect structure may include priority nodes among the plurality of nodes, other nodes being nonpriority nodes, the priority nodes and the nonpriority nodes being selectively interconnected.

5 In accordance with another aspect of the invention there is provided a system. The system includes a plurality of switches, and a plurality of interconnect structures coupled respectively to the plurality of switches, the interconnect structures being as defined above.

BRIEF DESCRIPTION OF THE DRAWINGS

10 The features of the described embodiments believed to be novel are specifically set forth in the appended claims. However, embodiments of the invention relating to both structure and method of operation, may best be understood by referring to the following description and accompanying drawings.

15 **FIGURE 1** is a block diagram that shows an example of a data interconnect structure in the form of a multiple-level 32:8 concentrator.

FIGURE 2 is a data structure diagram that shows the format of data carried through the interconnect structure in the form of packets.

FIGURES 3A and **3B** show examples of cells that can be used in the interconnect structure shown in **FIGURE 1** including different configurations of input and output ports.

20 **FIGURES 4A, 4B,** and **4C** are schematic block diagrams that show multiple examples of interconnections between cells that are suitable for usage in an interconnect structure such as the structure shown in **FIGURE 1**.

FIGURE 5 is a schematic block diagram illustrating a priority of cells in an interconnect structure that is variable with respect to level.

25 **FIGURES 6A** and **6B** are a schematic block diagrams that show two examples of groupings of interconnected cells into nodes.

FIGURE 7 is a schematic block diagram illustrates a system utilizing a plurality of concentrators.

30 **DETAILED DESCRIPTION**

 Referring to **FIGURE 1**, a block diagram shows an example of a data interconnect structure in the form of a multiple-level 32:8 concentrator **100** that includes three levels and K columns. Levels are hierarchical and enumerated 0, 1 and 2 from the bottom upward, and the columns are enumerated 0 through K-1 from left to right. The concentrator **100** receives input data from 32 lightly-loaded data-carrying lines and passes the data into eight lines that are more heavily-loaded. In the illustrative example, data packets travel in an eight-wide “ribbon” of rows from a 32-port input terminal **120** to an eight-port output terminal **122**. The ribbon **112** includes an eight-wide set of control cells **102** located in control arrays **110** at each column, and shift registers (FIFOs) **118**, located to the right of column K. The bottom output level does not include FIFOs. The topology of the ribbon **112** can be described as a wrapping in a barber-pole

35

40

5 fashion as is illustrated in **FIGURE 1**. Data are in the form of packets **200** illustrated in **FIGURE 2**. The ribbon **112** wraps around level 2 four times, around level 1 twice, and passes once through level 0. Accordingly, level 2 has 32 rows of cells and 32 FIFOs, level 1 has 16 rows of cells and 16

FIFOs, and level 0 has eight rows of cells with no FIFOs. The width of the ribbon is typically equal to the number of output ports although other configurations are practical.

The illustrative interconnect structure shown in **FIGURE 1** has an eight-wide ribbon of data transmission lines. The individual lines are divided into seven segments, each segment being sufficiently long to contain one message. Each data transmission line in the eight-wide ribbon connects a sequence of nodes. The eight-wide ribbon is wound into a typically spiral formation with some interconnection between nodes on different windings. Data can progress along the data transmission line from node to node in a first-in-first-out operation. Data moves from a system input port through the interconnect structure to a system output port. Each node B on the data transmission line L except a node in column 0 level 2 in the top eight lines of the interconnect structure has an immediate predecessor node A on the data transmission line L. Each node B on the data transmission line L has an immediate successor C that is on the data transmission line L or is an output port. The node A is always capable of sending data to node B. Node B is always capable of sending data to node C. Data sent from node A to node B and data sent from node B to node C are always unblocked.

Some nodes are located in a FIFO region of the ribbon. Nodes in the FIFO region have only one input port and one output port.

Some nodes have additional input ports that permit data to enter from outside the transmission line ribbon.

Some nodes have secondary input ports that enable data to enter the node from a node further upstream in the transmission line ribbon. The further-upstream node is typically on a previous winding of the ribbon in comparison to the present node.

Some nodes have one or more secondary output ports that enable data transmission further down the ribbon nearer to the ribbon system output ports. Nodes with multiple output ports have associated logic that always attempts to transmit the message forward towards the system output ports as far as possible rather than transmitting the message to the immediate successor node along the transmission line ribbon.

Nodes with multiple input ports have a priority assigned to the input ports. Messages from immediate successors always have priority over messages from nodes that are not immediate successors. Nodes that have multiple input ports connected to nodes that are not immediate predecessors also have a priority relationship for receiving data.

In summary, nodes always attempt to send data as far down the ribbon as possible but associated with each node B, a priority is defined to receive messages from the various nodes that are capable of sending messages to node B. The top priority is granted to the immediate predecessor node. A set S includes nodes that are capable of sending messages to the node B. A

1001.P007 WO (M-9458 WO)

FILED IN USPTO, 13092003

PCT/US01/50544

IPERALS

priority relationship is defined among the nodes in set S for sending the messages to the node B.

Rules governing the progression of messages forward follow:

1. If a node N is a member of set S and a message M arrives at node N, then node N is never blocked from sending message M to node B by a message from another node in the set S with a lower priority than node N for sending a message to node B.
2. Corresponding to each node N in the set S a set TN of nodes exists to which node N is capable of routing messages. Logic associated with each node N ranks the members of TN in a range from a node NM most desirable to receive message M to a node NL least desirable to receive message M. Logic associated with node N sends message M to the most desirable unblocked member of set TN.
3. The immediate predecessor node A to node B has the highest priority to send a message to node B.

In FIGURE 1, nodes with the ability to transmit and accept messages from nodes on previous windings of the transmission line ribbon, thus nodes that skip segments of the interconnect structure, are located in K control cell columns. Nodes with only a single input port are located in the FIFO section of the interconnect structure.

A message includes a payload preceded by a single-bit header - a single timing bit that is always set to one. Each of the segments corresponds to a row on a level. A row includes K control cells that span the row. Since the message must fit within the K control cells and the FIFO on a single row, the message length cannot exceed the length of the FIFO + CK where C is the number of bits in a control cell. Therefore, the length of the FIFO must be at least the length of the maximum message length less CK. If a system concentrates a large number of messages into R signals, then the ribbon width is R. If the interconnect structure contains L+1 levels and K columns per level, then the system contains $R \cdot (2^{L+1} - 1)$ rows with each row containing K control cells and a FIFO having a length of at least the maximum message length less C·K.

In one embodiment, messages are fed into one of the segments of the ribbon at column 0. As the message moves to column 1, the message can continue to pass further along the ribbon segment or the head (first bit) of the message can move ahead, leading the message to another segment nearer the system output port. When the message, lead by the first bit, moves to a new segment of the transmission line ribbon, the message may move to a different transmission line or stay on the same transmission line on the ribbon. When the head of the message reaches a new column, the message may again jump forward to a new segment. In this way, a message may span several segments and, since the bottom level has no FIFO, the first portion of a message may exit the concentrator before the entire message has entered the concentrator.

In the following description the term packet refers to a unit of data, typically in serial form. Examples of data packets include Internet Protocol (IP) packets, Ethernet frames, ATM

WO 02/34004

PCT/US01/50544

cells, switch-fabric segment such as a portion of a larger frame or a data packet, parallel computer inter-processor messages, or other data messages that have an upper length limit. A packet traveling across a level passes through K columns of control cells **102**. The packet traversing a level can pass directly from one cell to a cell in the next column on the same level. In one example, for packets traveling between cells on the same level, two bits of a packet are positioned in each of the cells. The same timing can be used in the system disclosed herein although the cell design of the present disclosure is simplified. The FIFO contains the proper number of bits of a packet such that when the packet enters an array at column 0, the header bit **202** is aligned with other header bits of packets that traverse the same level. In the example, a packet fits on a single row such that the timing of packets entering column 0 is synchronized with packets arriving from cells positioned above in the hierarchy.

Timing and control is achieved by assuring that the length in bits of the longest packet does not exceed the number of bits in the FIFO plus the sum of the number of bits in the columns. For example, for packets with an upper length of 400 bits arriving at 400 clock periods in a structure with 12 columns of control cells and each control cell holding two bits, the FIFO length is 376 bits. A first bit of a packet moves from a cell on a particular level to cell on the same level in the next column in two clock ticks or steps. A first bit of a packet moves from a cell on a particular level to a cell one level lower in the next column in one clock tick. Therefore, the length of the FIFOs that connect between levels is one bit fewer to account for the difference in timing between levels. The length of FIFOs that connect between levels is one bit fewer to account for the difference in timing between levels. Level timing is discussed in detail hereinafter.

The packet is inserted into input array **120** from one of 32 data input ports in the top level. One data input port serves each of the 32 lines in the top level. A packet is inserted in a serial fashion into each of the lines. A packet entering a cell from ribbon **112** in array **120** has priority over a packet attempting to enter the cell from outside the interconnect structure. No internal packet can block a packet from entering top eight rows of the structure, but a packet that traverses the top row of the top level can, under some blocking conditions, wrap around the “barber pole” and reenter the top level eight rows lower in array **120**. Packets entering the structure are never discarded so that any packet that enters the structure is guaranteed to exit, a substantial improvement over conventional concentrators.

The packet has priority to travel to the next column of switch arrays over a packet that attempts to enter the interconnect structure from outside the structure. The packet attempting to enter the structure under these circumstances is prohibited from entering. Although multiple aspects of operation affect transit through the interconnect structure, older packets probabilistically have priority of exiting before newer packets.

In alternative embodiments, packets can enter the ribbon in multiple angles in the top level. For a particular cell on the top level, the first bit of a packet entering the cell from within the structure coincides with the first bit of a packet entering a cell in the same column from outside of the structure.

5 Alternatively stated, at the top level 32 input lines accept packets from outside the structure. Of the 32 input lines, the top eight input ports are connected at the start of the ribbon and cannot be blocked by packets already in the structure. The remaining 24 input ports can be blocked. Blocking is discussed in detail in the description of **FIGURES 4A, 4B, and 4C.**

10 As an alternative to traveling around the spiral in the data-carrying ribbon, a packet can jump ahead from a cell on a higher level to a cell on a lower level in the hierarchy. The jumping process concentrates packets in the ribbon so that the segment of the ribbon at the bottom level advantageously carries more packets, on average, than the segment of the ribbon on the top level.

A packet on a given level enters a control cell **102** in a control cell array **110**. Referring to **FIGURE 4A**, when a packet P_A **410** enters a control cell **B**, logic associated with the control cell **B** can route the packet through the cell **B** to another cell **C** on the same level. Alternatively, the logic associated with the cell **B** can route packet P_A to a cell **X** on a lower level, which is the desired outcome of using the concentrator structure and operating method.

20 When a packet enters a cell **W** from above on line **106** or **404**, for example from cells **B** or **E**, the packet is sent without delay on line **104** to cell **X** in the next column. Therefore, when packet P_A is routed from cell **B** to cell **X**, packet P_A travels to cell **W** then immediately enters cell **X**. Referring to **FIGURE 4C** in combination with **FIGURE 4A**, when cell **B** routes packet P_A down to line **406**, the packet P_A similarly enters cell **X** immediately. The diagrams shown in **FIGURES 4A and 4B** are functionally-equivalent examples of packet routing between cells. Implementation considerations may influence the selection of one routing technique over another.

25 The immediate “dropping-down” or “jumping” of a packet to a lower level promotes efficient operation of the concentrator interconnect structure. Fundamentally, if a cell on a given lower level is unoccupied by a packet, thus available to accept data, and that cell is connected to another cell on a higher level, then a packet at the higher-level cell will drop to fill the empty spot in the lower-level cell. Several dropping or jumping processes are suitable. Control cell structure determines the dropping or jumping technique. Control cell structure and overall data flow and timing are discussed in detail hereinafter.

30 **FIGURE 1** is an illustrative embodiment of a 32:8 concentrator with an 8 wide ribbon and three levels with a 2:1 ratio between levels, which yields a concentrator with an overall 4:1 concentration ratio. Other concentrator ratios are practical, as are other ribbon widths, desirably providing for a wide variety of input and output port counts. The concentration ratio can be increased by adding additional levels, by increasing the concentration ratio between levels, or

both. An embodiment with a higher overall ratio than 4:1 has more than three levels. Other embodiments may use ratios other than a 2:1 ratio between levels. In the control cells illustrated in **FIGURE 1**, only a portion of the data carrying lines and control signal carrying lines are illustrated. The additional lines are discussed with reference to structures shown in **FIGURES 3A** and **3B** hereinafter.

FIGURE 2 illustrates a packet layout. A header **202** of a packet **200** includes a single bit that is always set to 1 and indicates that a packet is present. The remainder of the packet is called a payload **204**. Various kinds of payloads are exemplified in **FIGURE 2**. A packet can exit interconnect structure **100** from any output port so that additional header bits containing routing information are unnecessary.

If after leaving the concentrator **100**, the packet travels into a network routing device, routing information for usage by the routing device may precede data bits in the payload. The routing bits are not used by the logic of the concentrator **100**. The concentrator **100** always ignores payload contents **204**.

Alternate embodiments of a concentrator (not shown) may use additional header bits that indicate quality of service.

FIGURES 3A and **3B** show examples of input and output ports of a cell. In the illustrative port configurations, a cell **102** receives data on two data input lines **106** from cells on higher levels and sends data on one data output line **106** to a cell on a lower level. The 2-to-1 ratio of vertical connections assists the data-concentrating operation of the concentrator. The cell **102** also includes one data input line **104** from a cell on the same level and one data output line **104** to a cell on the same level. In addition to data input and output lines between cells, additional interconnect lines **108** carry control information between cells. The control information is used by logic of the receiving cell to determine how to route data packets from the receiving cell. The control lines are used to enforce priority-based-on-position rules that govern data flow through the interconnect structure.

As described herein, two nodes attempting to send data to a third node communicate using control signals to resolve upstream contention. In other networks, packets entering a node **N** contend for output ports. In the systems described herein, packets contend for node input ports and the contention is resolved upstream using control signals. Upstream data flow is permitted by the unique topologies in the disclosed networks that allow two packets to contend for a particular downstream node input port. Resolution of the contention is based at least in part on the position of the nodes in the network. A node **E** with priority over a node **B** to send data to a third node **V**, sends a control signal directly or indirectly to **B** to enforce that priority. **FIGURE 3A** depicts a node that receives one control signal and sends one control signal. **FIGURE 3B** depicts a node that receives one control signal and sends two control signals.

The use of the two types of nodes is described in more detail in the discussion of the interconnect structure shown in **FIGURE 4A**.

FIGURE 3B shows an example of a cell that has priority over one cell on a higher level and one cell on the same level.

5 **FIGURE 4A** is an enlarged depiction of a portion of the concentrator **100** shown in **FIGURE 1** with less than all data and control lines shown. Cells E and B are on the same level. Each of the cells E and B can individually be viewed as separate nodes, or the two cells E and B can be considered together as a single node.

10 The concentrator **100** operates in a manner that follows. For cells V, W, and X on the same level, if a packet P_V is sent by cell V to cell W, and cell W sends the first bit of packet P_V to cell X, then cell W sends a control signal to cell E at a higher level. Cell W sends packet P_V to cell X on line **104**. Cell W sends the control signal to cell E on line **108**, informing cell E not to send data down line **106**. Cell E in turn sends a control signal via line **402** informing cell B not to send data down line **404**. In the case that cell W sends packet P_V to cell X, any packet P_D **412**
15 entering cell E from cell D will be routed by the logic of cell E to cell F in the next column. Moreover, any packet P_A entering cell B from cell A will be sent from cell B to cell C.

If at a given packet-arrival time, cell W does not send a packet to cell X, then cell W informs cell E of the cell W condition that cell W is not sending a packet M to cell X.

20 Referring again to **FIGURE 4A**, control information is contained in a control signal carried on control line **108** that is sent by cell W to cell E to inform cell E that no packet is sent from cell W to cell X. The line **104** from cell W to cell X is unoccupied by a packet and available to accept data. If cell D sends a packet P_D to E in this condition, then cell E will detect the presence of packet P_D by reading the one-bit header **202** of P_D . Logic associated with cell E uses the control signal from cell W and the header bit from packet P_D to determine whether to route
25 packet P_D through cell W to cell X. Packet P_D is free to use the data line **104** from cell W to cell X because cell W is not currently using data line **104** to send another packet to cell X.

30 Any packet that enters cell W from the level above is always sent directly to cell X. In an illustrative concentrator, logic associated with cell W is capable of routing packets arriving at cell W from another cell on the same level as cell W but does not have any control over packets entering cell W from a higher level. Packets from the higher level are passed through cell W on the data interconnect line **104** from cell W to cell X. In case cell E routes a packet P_D downward through cell W to cell X, then cell E sends a control signal via control line **402** to cell B. The control signal carries information specifying that cell B is blocked from sending a packet on line **404** at this time. In the presence of the blocking control signal from cell E, if cell B receives a
35 packet P_A from cell A, then logic associated with cell B will cause the packet P_A to be routed from cell B to cell C through line **104**.

In one case, at a particular packet-arrival time, logic associated with cell W does not route a packet to cell X and cell E does not send a packet down line 106. Cell B is free to send a packet down line 404. Cell W sends a control signal, for example in the form of a single bit, through control line 108 informing cell E that cell W is not blocked from receiving a packet from cell E or cell B. Cell E responds to the control signal from cell W and absence of a message arriving from cell D by sending a control signal through line 402 informing cell B that cell W is not blocked from receiving a packet from cell B. If a packet P_A arrives at cell B at this time, then cell B sends packet P_A via line 404 through cell W to cell X. The packet P_A first travels through line 404 and then through line 104. Line 104 is free to carry packet P_A because line 104 is not used to carry a packet routed to cell X from either cell W or cell E.

Continuing with reference to **FIGURE 4A**, node W is connected to send a control signal to node E via a single control signal carrying line 108. In addition to the illustrated interconnect lines, the nodes on level J also have control signal carrying lines (not shown) capable of carrying control signals from a node on level J-1, and data carrying lines (not shown) capable of carrying packets from the level J node to a node on level J-1. For example, the node W has the port structure illustrated in **FIGURE 3A** including three data input ports, two data output ports, one control signal input port, and one control signal output port. Referring again to **FIGURE 4A**, the node E receives control signals from node W through a line 108. Node E sends control signals to the node B on the same level and, if node E is not on the top level, node E also sends a control signal to a node on level J+2. In addition to the illustrated interconnect lines, the nodes on level J+1, if not the highest level, also have additional data and control interconnect lines connecting to nodes on level J+2. For example, node E has a port structure as illustrated in **FIGURE 3B** including two data carrying lines from nodes on level J+2.

In case cell B is not on the top level, cell B is connected to a control line (not shown) for sending control signals to a cell on a higher level. The control line has the same function as the control line from cell W to cell E. If cell B sends packet P_A to cell C, then cell B sends a blocking signal to a cell on the next level above.

If cell B is in column K-1 and in the top 24 rows of the top level, then cell B is in a position to send a message through the FIFO into the cells that receive input data from a device outside of the concentrator. Cells like cell B that can send messages to other cells that also receive messages from outside the structure have a special control signal line that controls the flow of messages into the interconnect structure from a device outside of the structure. A control signal on the special control signal line informs a device outside of the structure of a possible busy condition in data input column 120.

If cell B is in column K-1 on the top level but not in the top 24 rows of the top level, then cell B does not send a control signal outside the structure.

If cell E is not in the top level then cell E sends two control signals. Cell E sends a blocking signal on control signal line 402 to cell B when cell E sends a packet to cell W. Cell E sends a blocking signal up on a control signal line 403 to the next higher level when cell E sends a packet to cell F.

5 If cell E is in column K-1 and in the top 24 rows of the top level, then cell E sends a special control signal that controls the flow of messages into the interconnect structure from a device outside of the structure.

10 Stated generally, nodes with priority to send packets downward in the hierarchy have two control signal-sending lines as shown in **FIGURE 4B**. Nodes without priority to send a packet down have only one control signal-sending line.

FIGURES 4A and **4B** depict alternative embodiments of interconnect structures that are logically the same. A physical difference is that the structure shown in **FIGURE 4B** sends packets from cell B to cell X first through cell E and then through cell W. A message can jump from cell B to cell X when cell E does not otherwise use line 106 to send data, and neither cell E nor cell W use line 104 to send data to cell X. The control structure shown in **FIGURES 4A** and **4B** are the same and include control lines

15 **FIGURE 4C** depicts a third embodiment of an interconnect structure that is logically the same as the interconnect structures shown in **FIGURES 4A** and **4B**. In **FIGURE 4C**, cells E and B send packets directly to cell X, not through intermediate nodes. Control line structures are the same in the interconnect structures shown in **FIGURES 4A**, **4B**, and **4C**. The structures shown in **FIGURES 4A**, **4B**, and **4C** are physically different but logically equivalent.

20 Successful operation of the concentrator depends at least partly on timing. The first bit of the packet P_v arrives at node W at a prescribed packet arrival time. The logic associated with the node W makes routing decisions based on the single bit header 202 of packet P_v and the incoming control signal from a node on level J-1. If a packet P_v is present at node W and is not blocked from a node on a lower level, then node W sends packet P_v to a lower level and sends a control signal to the node E on a higher level. The control signal from node W arrives at node E at the same time or near the same time that packets arrive at node E. Logic controls the timing so that packets arrive at node W before the packets arrive at node E.

30 Referring to **FIGURE 4C**, for example an optical embodiment, logic predetermines a packet arrival time for packets arriving at node X. A packet sent from node E to node X must arrive at node X at the same time as a packet sent from node W to node X. As described hereinbefore, packets arrive at node W before packets arrive at node E. Therefore, the time for a packet to travel from node E to node X must be less than the time for packets to travel from node W to node X. In an optical embodiment, timing is adjusted by selecting the fiber length of the interconnect line from node W to node X to be shorter than the fiber length of the interconnect

line from node E to node X. In this way, packets from a higher level can catch up to packets on a lower level to synchronize arrival time.

In electronic embodiments, packets traveling between two nodes on the same level pass through two one-bit shift register cells. Nodes moving down a level bypass one of the register
 5 cells so that in the structures shown in **FIGURES 4A, 4B and 4C**, a packet bit travels from cell E to cell F in two clock cycles and from cell E to cell X in one clock cycle.

The structures shown in **FIGURES 1, 3A, 3B, 4A, 4B and 4C** have the same priority for sending messages through the interconnect structure. Node W, the immediate predecessor of node X has first priority to send to node X. Node E has second priority to send to node X. Node
 10 B has third priority to send to node X where node X is closer to the output ports of the ribbon than node B. In other embodiments, the node furthest from the output end of the ribbon has priority. Referring to **FIGURE 5**, the priority is variable with respect to columns so that if node B is an immediate successor to node A and node A is a cell without priority, then node B is a cell with priority.

FIGURE 5 illustrates three columns and three levels of the interconnect structure. On
 15 each level and in each column is an array **110** of control cells **102**. Cell-to-cell interconnections in the structure shown in **FIGURE 5** are the same as the interconnections illustrated in **FIGURE 4B**. Cells are paired to form a node **502** so that both cells of the node pair are positioned to send data to a single node on the next lower level. In highly suitable embodiments of the concentrator,
 20 cells **102** on rows **104** within a control array **110** are randomly placed. Software simulation of a plurality of random placements can be performed to desirably select best-performing arrangements. Solid boxes **504** illustrate cells with higher priority in a node. Open boxes illustrate cells with low priority. The illustrative nodes each contain one higher priority cell and one lower priority cell. Along a row **104**, a packet that has low priority at one column
 25 advantageously always has high priority at the next column on the same level.

If a node is considered to include only a single control cell, then each node has one data input line from the same level. Nodes that are not on the top level have two data input lines from a higher level. Each node has a data output line to one node on the same level. Nodes that are not
 30 on the bottom level have an additional data output line to a lower level. Each node that is not on the bottom level has one control input port. Nodes that are not on the top level have either one or two control signal output ports. Only nodes at an input column or columns have control signal output lines to external input sources. Input sources are allowed to send a packet into the concentrator only at a time indicated by a global clock signal, and only if no corresponding blocking signal is received from the top-level node. Input devices use the same timing and
 35 routing rules for sending a packet "down" into the concentrator that internal cells follow for routing a packet down to a lower-level cell.

One having ordinary skill in the art will readily implement many variations, modifications, additions and improvements of the basic concentrator described herein.

Alternative Topology Embodiments

In the concentrator disclosed hereinabove, a line leaving the FIFO on row J is connected
5 to a line on row J-8 entering column 0. In a first alternative example, the line leaving the FIFO on row J is connected to the line entering column 0 on the same row J. The topology is changed such that the top level has 32 rings, the next level down in the hierarchy has 16 rings, and the bottom level has eight rings.

In a second alternative example, a permutation is made between column K-1 and the
10 FIFO column. A line leaving the FIFO on row J is connected to a line entering column 0 on the same row J. For some permutations, the resulting topology has one ring on each of the levels. In some cases data is always allowed to leave the concentrator from the output ports on column k-1 on level 0. In such cases the novel "barber pole" structure shown in **FIGURE 1** advantageously operates so that messages entering the top of the structure are always guaranteed to exit the
15 structure in an amount of time bounded by a fixed constant.

In other cases, data under some conditions may be blocked from leaving the concentrator output ports, a structure with one ring per level may be more suitable.

Quality of Service Embodiment

One simple technique for implementing quality-of-service (QOS) priority in networks
20 and concentrators is to include one or more additional header bits to designate a quality of service level. Referring to **FIGURE 4A**, a QOS priority technique is implemented. If packet P_D has the same or higher QOS priority as packet P_A , and cell W does not send a packet P_V to cell X, then packet P_D is sent to cell X. However, if packet P_D has a lower QOS priority than packet P_A and cell W does not send a message P_V to cell X, then packet P_A is sent to cell X. To implement QOS
25 priority, cells E and B are capable of reading the QOS header bits, and a control line from cell B to cell E carries QOS information. Cell B is capable of transmitting QOS information to cell E either via the existing line **108** or via an additional control line.

Additional Level Embodiment

The illustrative example excludes buffers from the nodes. However, the concentrator
30 does operate in the manner of a buffer and thus can handle bursty traffic. For example, if the average number of messages entering the concentrator is less than eight but occasionally more than eight messages enter the concentrator, possibly none of the messages that are targeted to enter the concentrator are blocked. The ability to handle bursty traffic can be increased by adding an additional level, level 3 in the example, to the concentrator. Level 3 can have 64 rows with
35 data entering the top 32 rows. Inclusion of the additional level increases the effective buffer size

of the entire concentrator. In other embodiments, several additional levels can be added to the structure to further increase the ability to handle bursty traffic.

Multiple Input Column Embodiment

One technique for implementing a 64:8 concentrator includes adding an additional level 3
5 with 64 rows using an eight-wrap ribbon. In an alternative technique, an additional input port
terminal column is added to level 2, potentially doubling the amount of data that is received at the
32 lines in level 2. An additional shift register FIFO column can be added to level 2 to handle the
increased traffic on the 32 lines. Whether the additional FIFO column is warranted depends on
the timing of messages applied to the concentrator from input devices. Messages enter an input
10 column from outside of the concentrator as messages enter the input column from nodes within
the concentrator. The alternative technique is useful in applications in which the average data rate
per input channel is lower and less bursty.

Different Interconnect Between Levels Embodiment

Each node includes a single control cell and each node at a lower level is connected to
15 only one node at a higher level in the hierarchy. The concentrator can be adapted so that only half
the lines in a particular level above the bottom level sends messages down to the next lower level
in a particular time step.

In one embodiment, four control cells are combined into a single node that is capable of
sending data to four cells. One having ordinary skill in the art can modify the structure so that
20 four cells on a particular level form a node that is capable of sending data to two cells on a lower
level.

Referring again to **FIGURE 5**, two control cells on a level are positioned to send data to
a single control cell on the next level lower in the hierarchy. Node **502** illustrates the structure of
a 2:1 node concentrator in which two cells in a node are capable of sending data to one node on a
25 lower level. In an operational example, a message M_1 is sent from the control cell on row 2 of
level 1, column 0, to the cell on row 2 of level 1, column 1. In the same operational time period,
a message M_2 arrives at the control cell on row 8 of level 2, in column 0. Message M_1 is
positioned to block message M_2 and message M_2 will remain on the same level. Therefore, in the
topology shown in **FIGURE 5**, a single message on a level can block a message on one level
30 higher.

Referring to **FIGURES 6A** and **6B** cells are grouped, for example into nodes **602**, so that
four cells on a level are positioned to send data to two cells on a next lower level on interconnect
lines **604**. A node on each level contains four control cells. Each of the four cells in the leftmost
node on level 2 is capable of sending data to either of two cells on level 1. In one example shown
35 in **FIGURE 6A**, four cells in node N are capable of sending data to cells Q and R of node P.
Similarly, four cells in node M are capable of sending data to cells S and T in node P. No one

message on a level can block a message on a higher level so that throughput from one level to the next lower level can be increased. **FIGURE 6A** illustrates the structure of a 4:2 node concentrator in which four cells in a node are capable of sending data to either of two nodes on a lower level. In other embodiments, for example as shown in **FIGURE 6B**, logic can be added to increase the number of cells in a node **610**. For example, all eight cells in nodes T and U can be controlled in combination to send data to all four cells in either or both of nodes V and W to form an 8:4 node concentrator. More complex nodes are used in designs that have increased throughput at the expense of more logic per node.

Referring to **FIGURE 7**, a schematic block diagram illustrates a system utilizing a plurality of concentrators and a plurality of switches to form a larger network from several chips. An alternative embodiment arranges smaller networks into a twisted cube. The system illustrated in **FIGURE 7** improves the twisted cube structure.

In practice, extremely large networks can be built using the illustrative multiple-chip modules. For example, 128 switch chips and 128 concentrator chips can be combined. For example, each of the 128 chips can contain 64 one-line input ports and 64 three-line output ports. The combination forms a single-chip with 64^2 input lines and 64^2 output lines. The example illustrated in **FIGURE 7** is a much smaller system that is useful for illustrative purposes. Much larger systems can be practically constructed.

Networks **702** and **704** shown in **FIGURE 7** have three levels and a plurality of columns. Each level has four rows. Three of the columns on level 0 contain output ports. In the illustrative system, each of the chips **702** has three output lines that are sent to address 0, three output lines sent to address 1, three output lines sent to address 2, and three output lines sent to address 3. The bottom concentrator receives all twelve output lines that are connected to address 0. The three other concentrators each receive twelve input lines that are connected to the addresses 1, 2, and 3 as is appropriate.

Other networks send data from the different columns at different times. In the system shown in **FIGURE 7**, messages from different columns pass through suitable delay line FIFOs (not illustrated) so that the messages from all columns arrive at the concentrators **700** at the same time.

Concentrators **700** have 4-wide ribbons of rows on 3 levels so that level 0 has four rows, level 1 has eight rows and level 2 has sixteen rows. On level 2, the lower twelve of the sixteen rows are positioned to receive data from switches **702** at an input port (not shown) of the concentrator **700**.

For applications in which data is expected to be extremely bursty, additional layers may be added to the concentrators **700**. Concentrators **700** concentrate data from twelve channel output lines from each chip in the first column onto four input lines in the second row. The

concentrators also spread or disperse the data in time to reduce the possibility of hotspots. Data from the concentrators **700** is applied into a second column of switch chips **704**.

Messages exit the concentrators **700** synchronously so that no FIFOs are needed between the concentrator modules **700** and the switch chips **704**. Messages emerge from switches **704** and pass through FIFOs (not shown) to align the messages in time for entry into a second column of concentrator modules **706**. Each of the concentrator chips **706** contains four concentrators. Each of the four concentrators in concentrator chip **706** has a ribbon with the width of one row.

The second-column concentrators can be designed with three levels with level 0 having one row, level 1 having two rows and level 2 having four rows. Three of the four rows in the top level are capable of receiving input data. Again, for bursty traffic, the addition of additional rows to the concentrators in concentrator chips **706** may be warranted.

Control lines (not shown) supply control signals from downstream chips to upstream chips to inform the upstream chips of data blocking conditions in downstream chips. For example, if switch **704** is not able to receive data from concentrator **700**, then that data is redirected to one of the top rows of the concentrator **700**. Since only the lower twelve rows of the concentrators **700** receive messages from the upstream switches **702**, the top four rows are always free to receive data.

Control lines back to the top switch can come from a number of places. In one embodiment, buffers can be placed between the concentrator **800** and the switch **804**. When the buffers fill above a capacity level, control signals can be selectively sent to output ports of switches **802** that feed the filled buffers. Alternatively, the control signals can originate from within the concentrator from nodes located in upper levels in columns to the left that receive messages in congested traffic but do not receive messages in light traffic. The control signals block particular output ports of switch **800** based on traffic in the concentrator.

For all sizes of concentrators, feedback of blocked messages to the top rows of a concentrator is always successful because the maximum number of messages to be fed back is equal to the width of a ribbon and the ribbon-width is always open in the top rows of the concentrator.

While the invention has been described with reference to various embodiments, it will be understood that these embodiments are illustrative and that the scope of the invention is not limited to them. Many variations, modifications, additions and improvements of the embodiments described are possible. For example, those having ordinary skill in the art will readily implement the steps necessary to provide the structures and methods disclosed herein, and will understand that the process parameters, materials, and dimensions are given by way of example only and can be varied to achieve the desired structure as well as modifications which are within the scope of the invention. Variations and modifications of the embodiments disclosed

WO 02/34004**PCT/US01/50544**

herein may be made based on the description set forth herein, without departing from the scope and spirit of the invention as set forth in the following claims. For example, one or ordinary skill in the art could similarly apply the first and second quality-of-service techniques to the other interconnect structures described herein.

- 5 In the claims, unless otherwise indicated the article “a” is to refer to “one or more than one”.

THE EMBODIMENTS OF THE INVENTION IN WHICH AN EXCLUSIVE PROPERTY OR PRIVILEGE IS CLAIMED ARE DEFINED AS FOLLOWS:

1. An interconnect structure comprising:

5 a set S of parallel data paths such that data in a packet form can enter the data paths from one or more devices external to the interconnect structure and travel in wormhole transmission on one or more data paths of the set S to a data output port, wherein at a node A on a data path P of set S:

10

data moves from the node A to a node B that is an immediate successor to the node A on the data path P so that the data movement from the node A to the node B moves is a one step movement closer to the data path P data output port; or

15

based on precedence of data traveling through the interconnect structure data moves from the node A to a node C on a data path Q of the set S wherein the data changes from movement on the data path P to movement on the data path Q, the node C being closer to the data path Q data output port than the node B is to the data path P data output port.

20

2. An interconnect structure in accordance with Claim 1 further comprising:

25

a node D on the data path Q that is an immediate predecessor to the node C wherein data traveling from the node D to the node C has precedence over data traveling from the node A to the node C.

3. An interconnect structure in accordance with claim 1 wherein:

30

the interconnect structure handles high traffic conditions without discarding data.

4. An interconnect structure comprising:

a plurality of transmission rings;

a plurality of nodes arranged in the plurality of data transmission rings;

5

the data transmission rings being arranged in a plurality of levels from a highest level L to a lowest level 0, the data transmission rings comprising a plurality of windings wherein the number of data transmission rings in a winding decreases from the highest level L to the lowest level 0;

10

rings on level L having one or more nodes capable of receiving data from outside the interconnect structure;

15

the plurality of nodes including nodes A, B, C, X, and Y, the node B being on a level J between level 0 and level L;

the node A being an immediate predecessor to the node B on the same data transmission ring as the node B;

20

the node C being an immediate follower to the node B on the same data transmission ring as the node B;

the node X being on a level K greater than the level J;

25

the node Y being on a level P smaller than the level J;

the node B being capable of receiving data from the node A and the node X; and

30

the node B being capable of sending data to the node C and the node Y, the data being self-routed using no header information identifying a target for a data message.

5. An interconnect structure in accordance with claim 4 wherein:

the data is self-routed at least in part based on quality of service information included in the header.

- 5 6. An interconnect structure comprising:

a plurality of data transmission lines;

10 a plurality of nodes arranged on the plurality of data transmission lines, the plurality of data transmission lines arranged in a plurality of windings wherein the number of data transmission lines in a winding decreases from input to output of the interconnect structure;

15 the plurality of nodes including a node B and a subset S of nodes, the node subset S including one or more nodes capable of sending data to the node B, the nodes in the subset S having a priority relationship for sending a message to the node B so that for a node N in the subset S and a message M arriving at the node N then the node N is never blocked from sending the message M to node B by a message from a
20 node in the subset S with lower priority than the node N for sending a message to the node B, the plurality of nodes being capable of routing the message M in the absence of routing information for the message M.

7. An interconnect structure according to claim 6 further comprising:

25

a node subset T_N being a subset of nodes to which the node N is capable of routing messages; and

30

a logic associated with the node N that ranks members of the subset T_N from a node most desirable to receive the message M to a node least desirable to receive the message M, the logic associated with the node

N sending the message M to the most desirable unblocked member of the subset T_N .

8. An interconnect structure according to claim 6 further comprising:

5 a node A that is an immediate predecessor to the B, the node A having the highest priority to send a message to the node B.

9. An interconnect structure comprising:

a plurality of nodes arranged in a structure including:

10

an hierarchy of levels from a source level to a destination level;

a plurality of nodes in nonintersecting paths extending along the levels; and

15

a plurality of nodes in a cross-section of the nonintersecting paths of the levels, the number of nodes in a cross-section of the source level being greater than the number of nodes in a cross-section of the destination level so that the interconnect structure is a concentrator, the level of a node being determined entirely by the position of the node in the structure; and

20

a plurality of interconnect lines coupling the nodes in the structure including for a node N on a pathway P of a level L:

25

a message input interconnect line coupled to a first adjacent node on the pathway P of the level L;

30

a message output interconnect line coupled to a second adjacent node on the pathway P of the level L;

a plurality of FIFO buffers coupled to the respective nonintersecting paths extending along the levels.

13. An interconnect structure according to Claim 9 wherein:

5 the plurality of interconnect lines coupling the nodes in the structure including for the node N on a pathway P of a level L further include:

a first control output interconnect line coupled to a node toward the source with respect to the pathway P and in the level L; and

10

a second control output interconnect line coupled to a node in a level toward the source with respect to the level L.

14. An interconnect structure according to Claim 9 wherein:

15 the plurality of interconnect lines coupling the nodes in the structure including for the node N on a pathway P of a level L further include:

a first message input interconnect line coupled to a node toward the source with respect to the pathway P and in the level L;

20

a second message input interconnect line coupled to a node in a level toward the source with respect to the level L; and

25

a control output interconnect line coupled to a node toward the source with respect to the pathway P and in the level L.

15. An interconnect structure according to Claim 9 wherein:

the plurality of interconnect lines coupling the nodes in the structure including for the node N on a pathway P of a level L further include:

30

a first control output interconnect line coupled to a node toward the source with respect to the pathway P and in the level L;

5 a second control output interconnect line coupled to a node in a level toward the source with respect to the level L; and

a message input interconnect line coupled to a node toward the source with respect to the pathway P.

10 **16.** An interconnect structure according to Claim 9 further comprising:

priority nodes among the plurality of nodes, other nodes being nonpriority nodes, the priority nodes and the nonpriority nodes being selectively interconnected.

15 **17.** An interconnect structure according to Claim 9 further comprising:

a logic that interconnects nodes into groups to concentrate n nodes on a path toward the source to m nodes on a path toward the destination, n being greater than m and n:m being a concentration ratio.

20 **18.** An interconnect structure according to Claim 9 further comprising:

25 a ribbon of interconnect lines connecting a plurality of nodes in the nonintersecting paths, the ribbon of interconnect lines winding through the levels from the source level to the destination level, the number of turns of a winding decreasing from the source level to the destination level; and

a plurality of columns coupling the nodes in cross-section of the ribbon through all windings of the levels.

30 **19.** An interconnect structure according to Claim 18 wherein:

the number of windings of the interconnect line ribbon is reduced by one-half for each level from the source level to the destination level.

20. A system comprising:

5 a plurality of switches; and

a plurality of concentrators coupled respectively to the plurality of switches, the concentrators according to Claim 9.

21. An interconnect structure comprising:

10

a ribbon of interconnect lines connecting a plurality of nodes in nonintersecting paths, the ribbon of interconnect lines winding through a plurality of levels from the source level to the destination level, the number of turns of a winding decreasing from the source level to the destination level; and

15

a plurality of columns formed by interconnect lines coupling the nodes across the ribbon in cross-section through the windings of the levels.

22. An interconnect structure according to Claim 21 further comprising:

20

a plurality of input ports coupled to the nodes in a first column of the source level.

23. An interconnect structure according to Claim 21 further comprising:

25

a plurality of output ports coupled to the nodes in a last column of the destination level.

24. An interconnect structure according to Claim 21 further comprising:

a plurality of FIFO buffers coupled to the respective nonintersecting paths extending along the levels.

25. An interconnect structure according to Claim 21 further comprising:
the number of windings of the interconnect line ribbon is reduced by
5 one-half for each level from the source level to the destination level.

26. An interconnect structure according to Claim 21 further comprising:

control lines extending from nodes inside the interconnect structure to
one or more devices outside the interconnect structure to control entry
10 of messages into the interconnect structure.

27. An interconnect structure according to Claim 21 further comprising:

a logic that interconnects nodes into groups to concentrate n nodes on a
path toward the source to m nodes on a path toward the destination, n
15 being greater than m and $n:m$ being a concentration ratio.

28. An interconnect structure according to Claim 21 further comprising:

a logic that is capable of determining whether a node is occupied by a
message on the path of a level and on the basis of the determination
20 sending a control signal to a node toward the source, speeding
advancement of a message at the node toward the source.

29. An interconnect structure according to Claim 21 further comprising:

priority nodes among the plurality of nodes, other nodes being
25 nonpriority nodes, the priority nodes and the nonpriority nodes being
selectively interconnected.

30. A system comprising:

a plurality of switches; and

a plurality of interconnect structures coupled respectively to the plurality of switches, the interconnect structures according to Claim 21.

5

31. An interconnect structure according to Claim 2 wherein:

a data packet moves through the interconnect structure independent of target output information contained in the data packet.

10

32. An interconnect structure according to Claim 1 wherein:

the data path Q is separate and distinct from the data path P.

33. An interconnect structure according to Claim 1 wherein:

15

the data path Q and the data path P are the same data path.

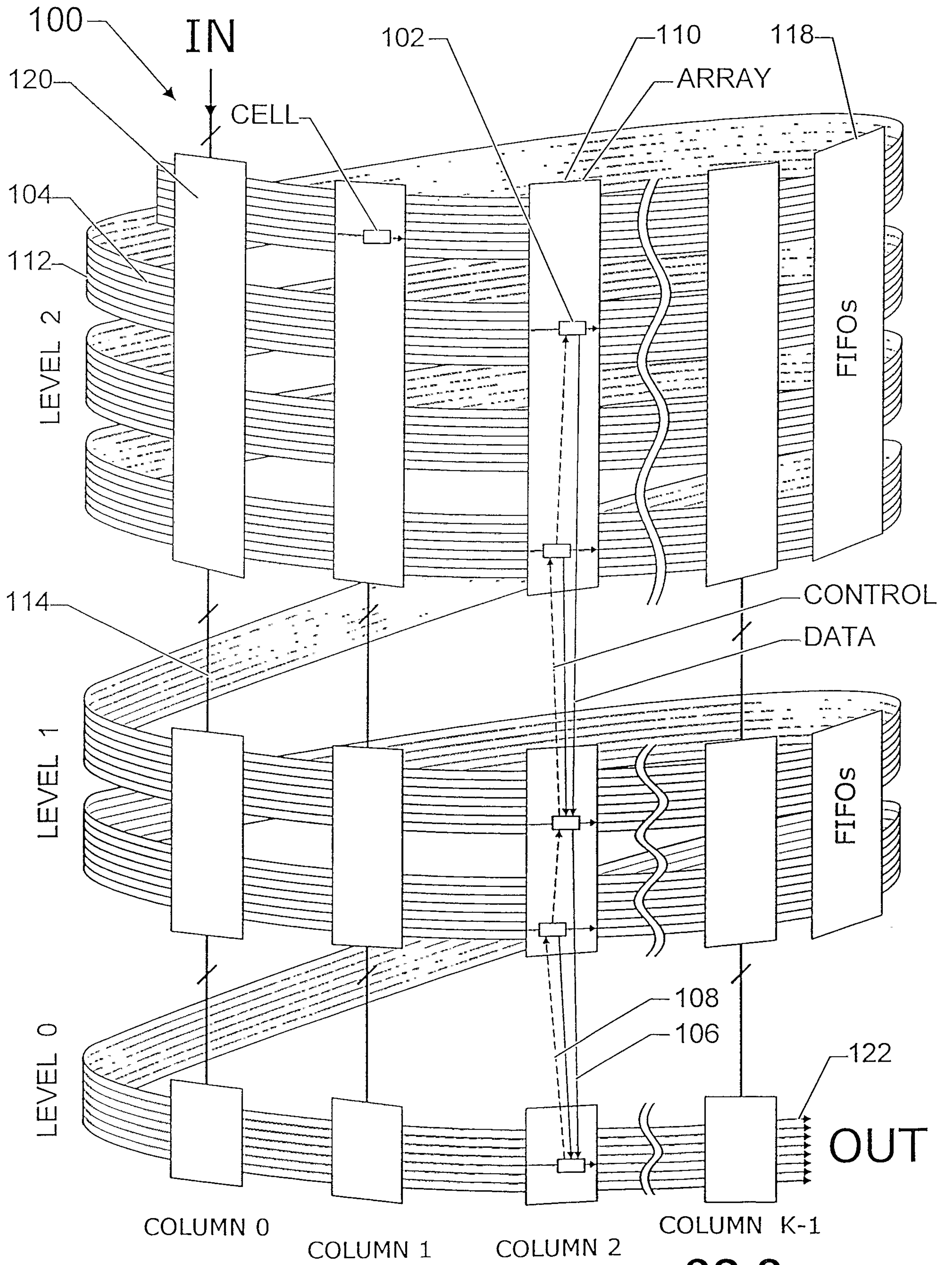

Fig 1

32:8

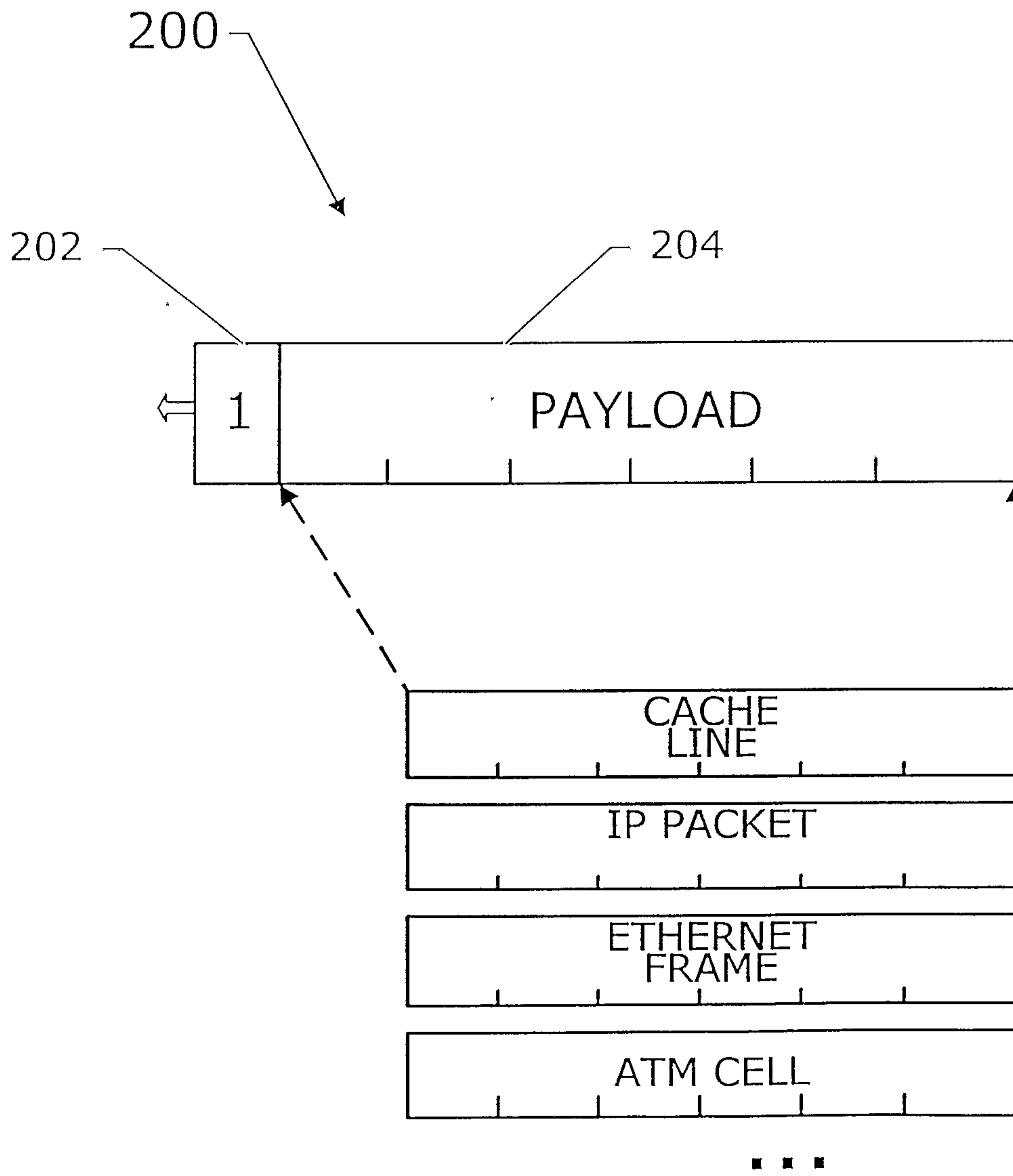

Fig 2

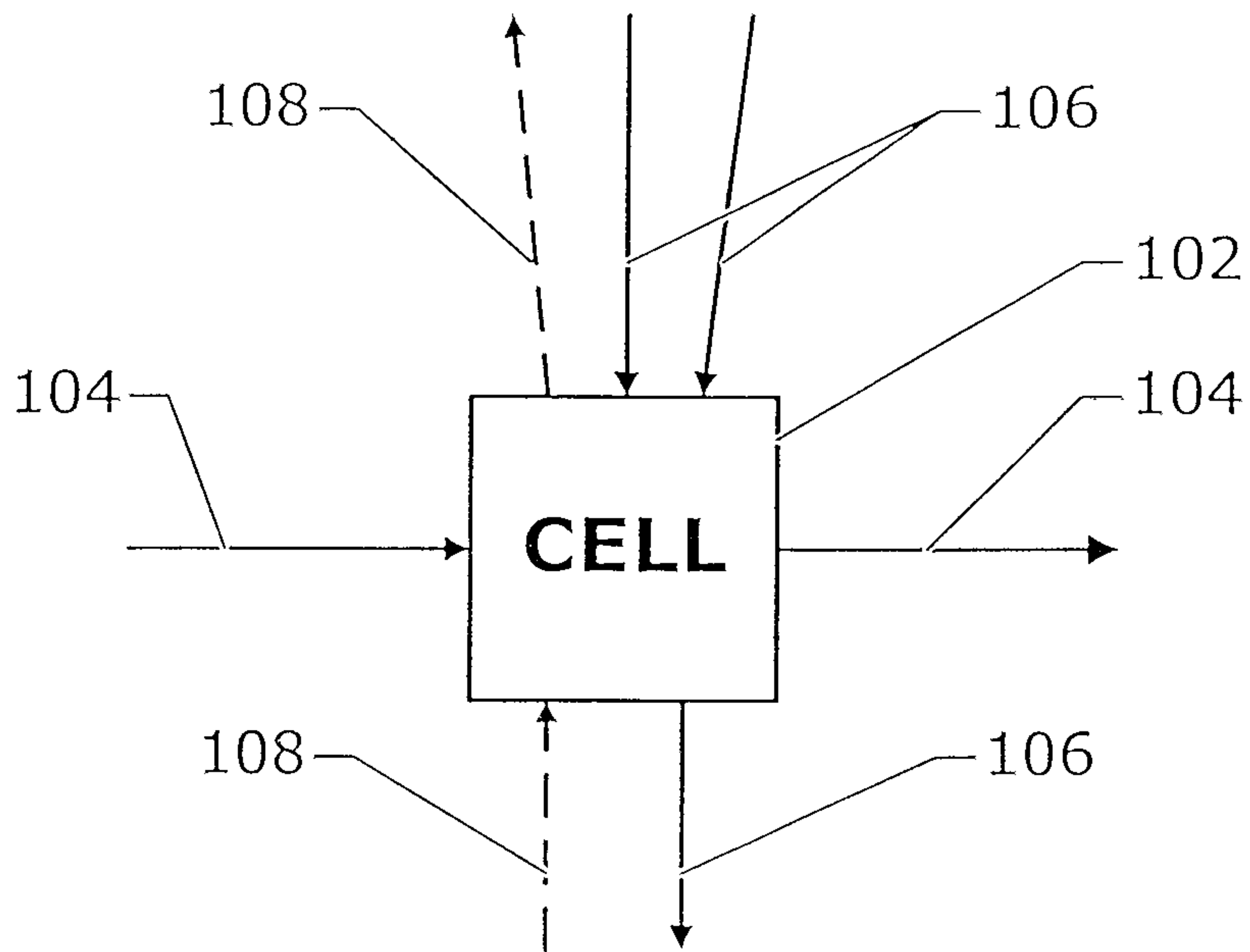

Fig 3A

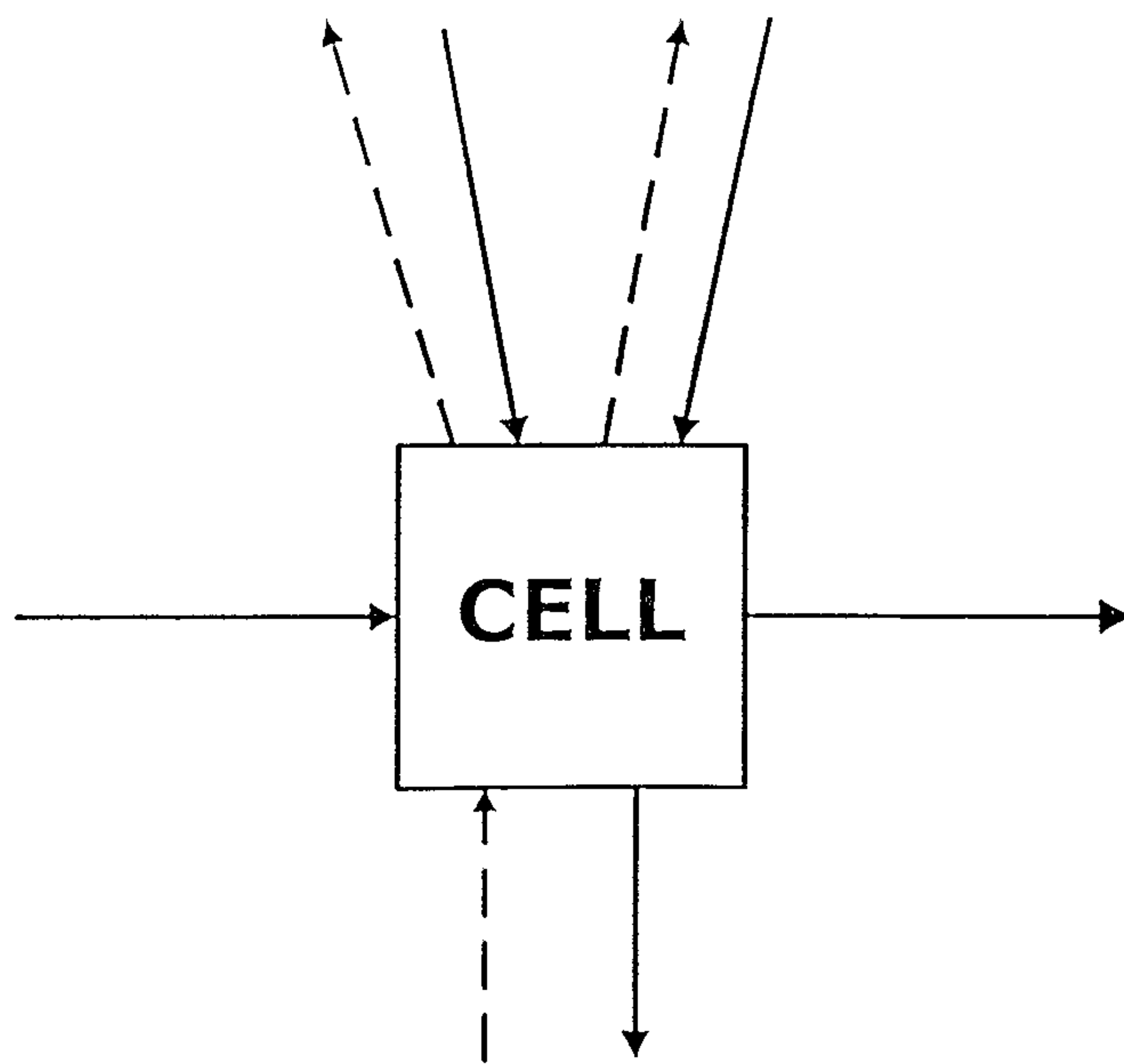

Fig 3B

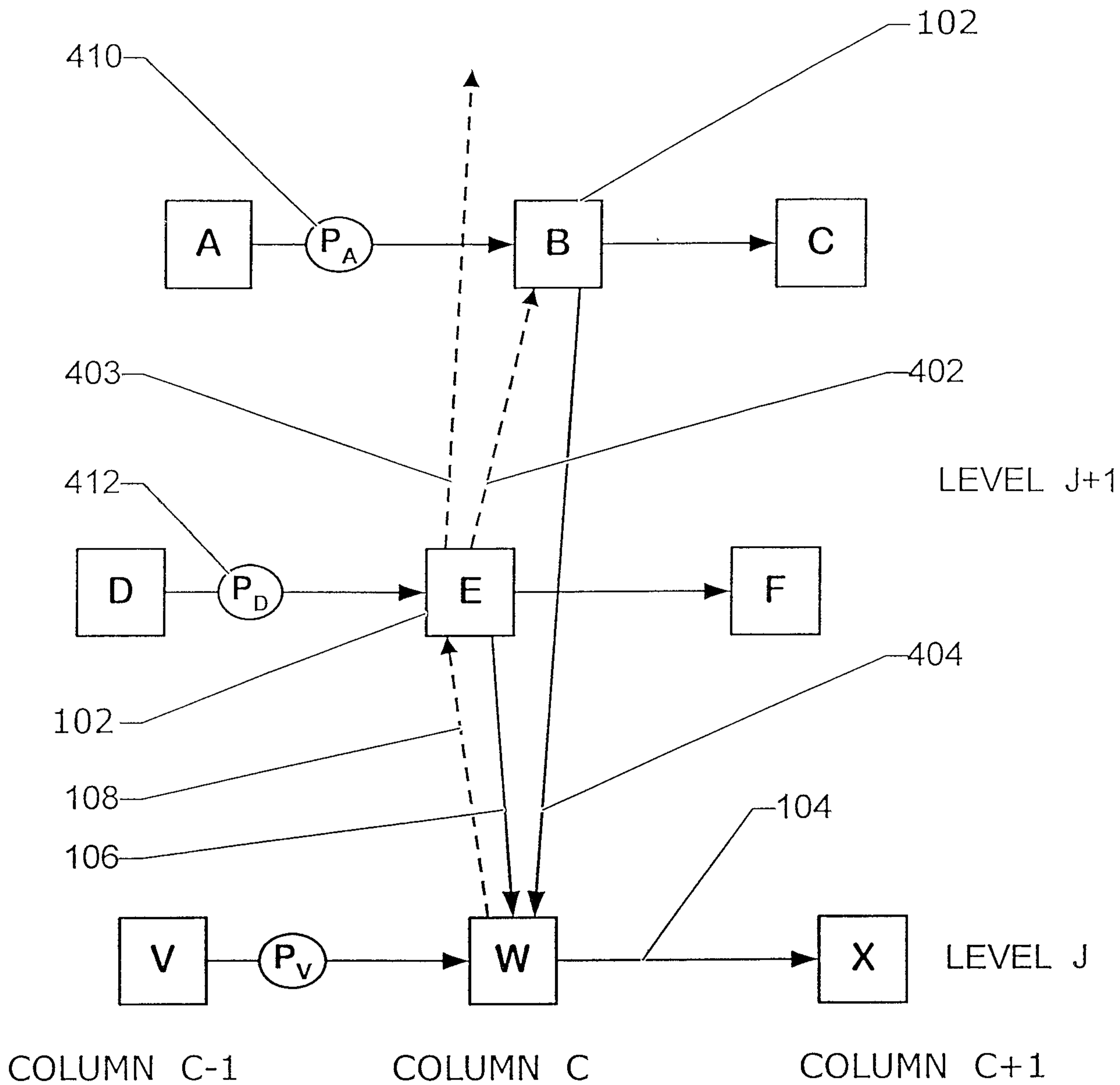

Fig 4A

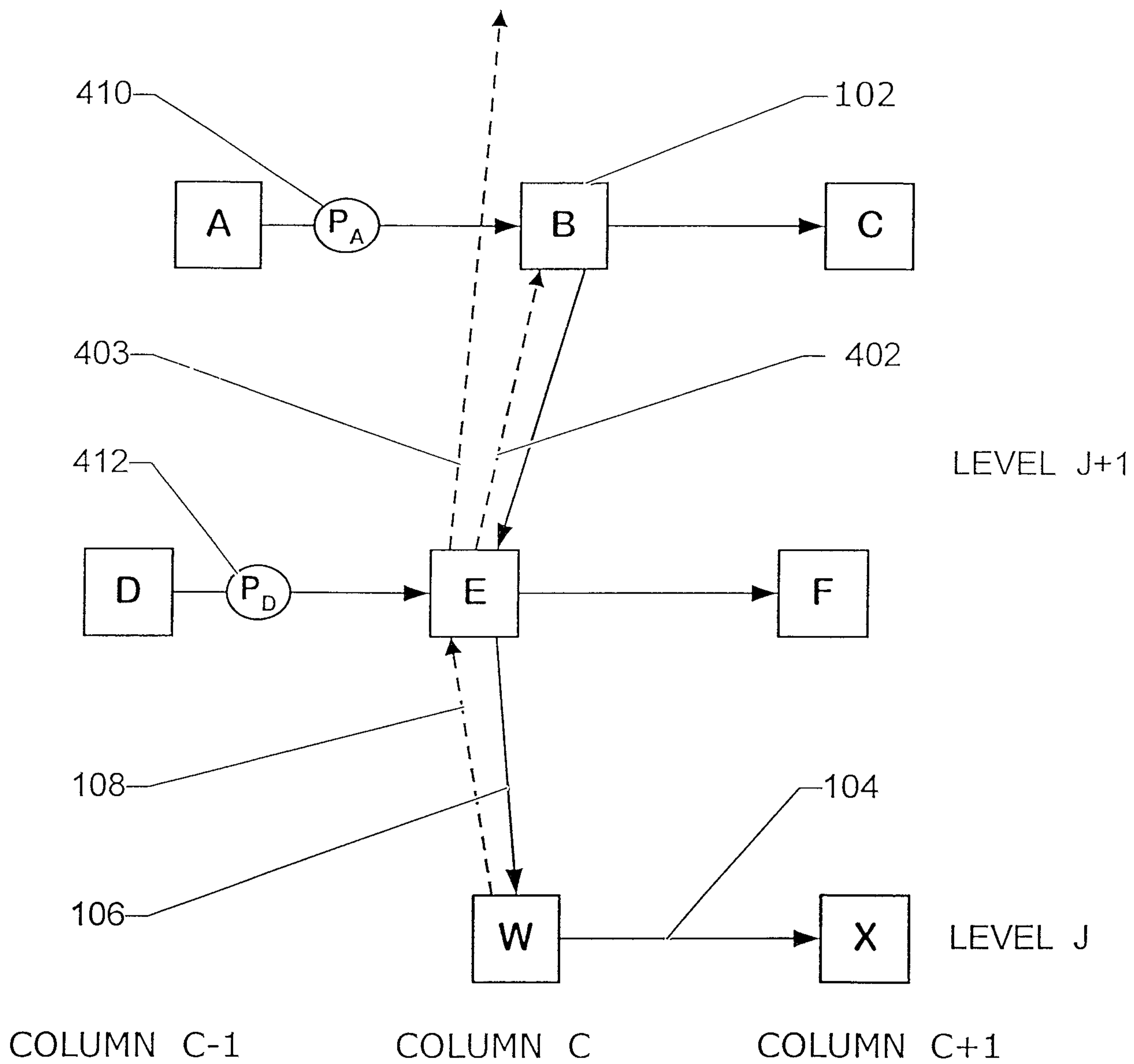

Fig 4B

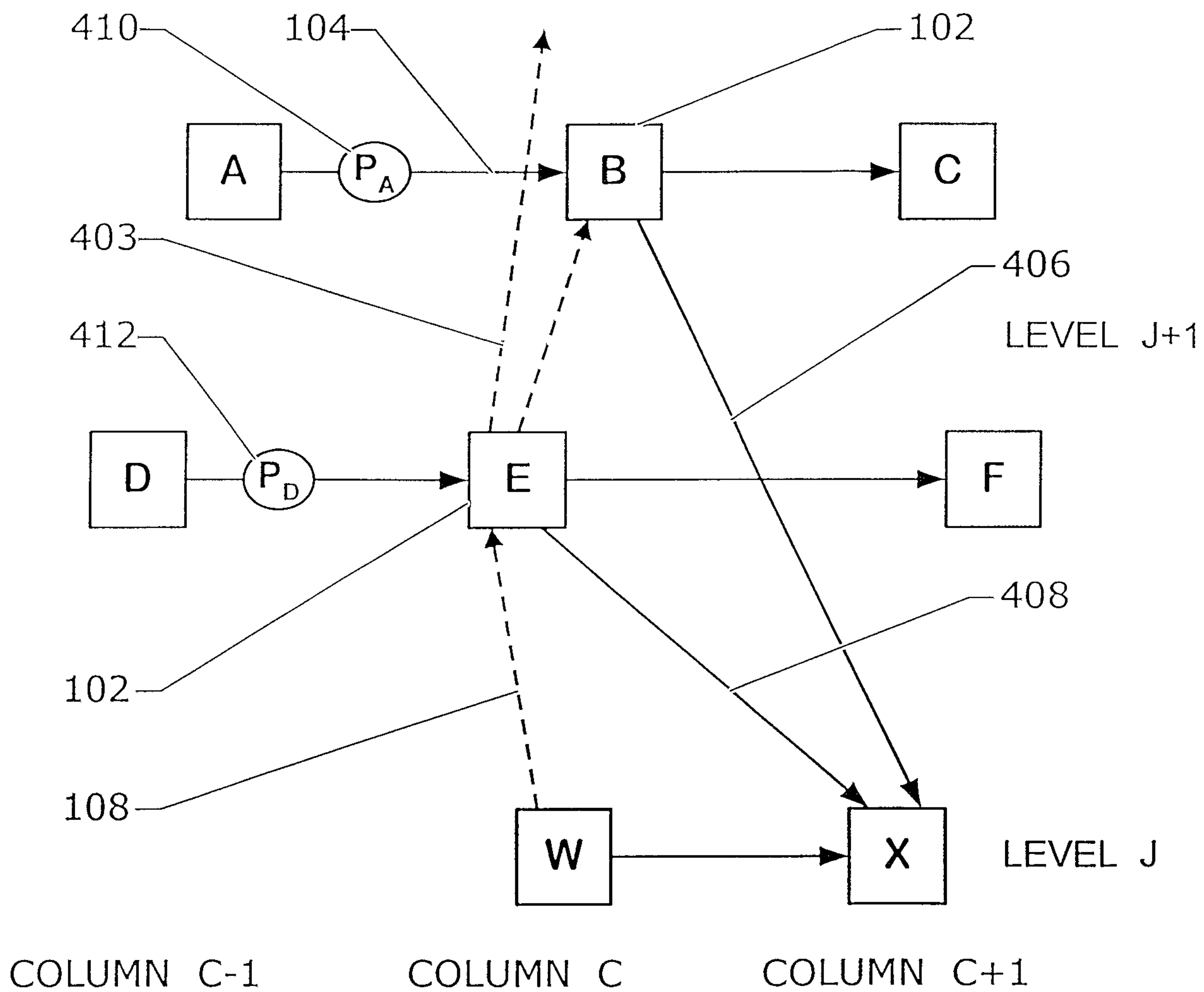

Fig 4C

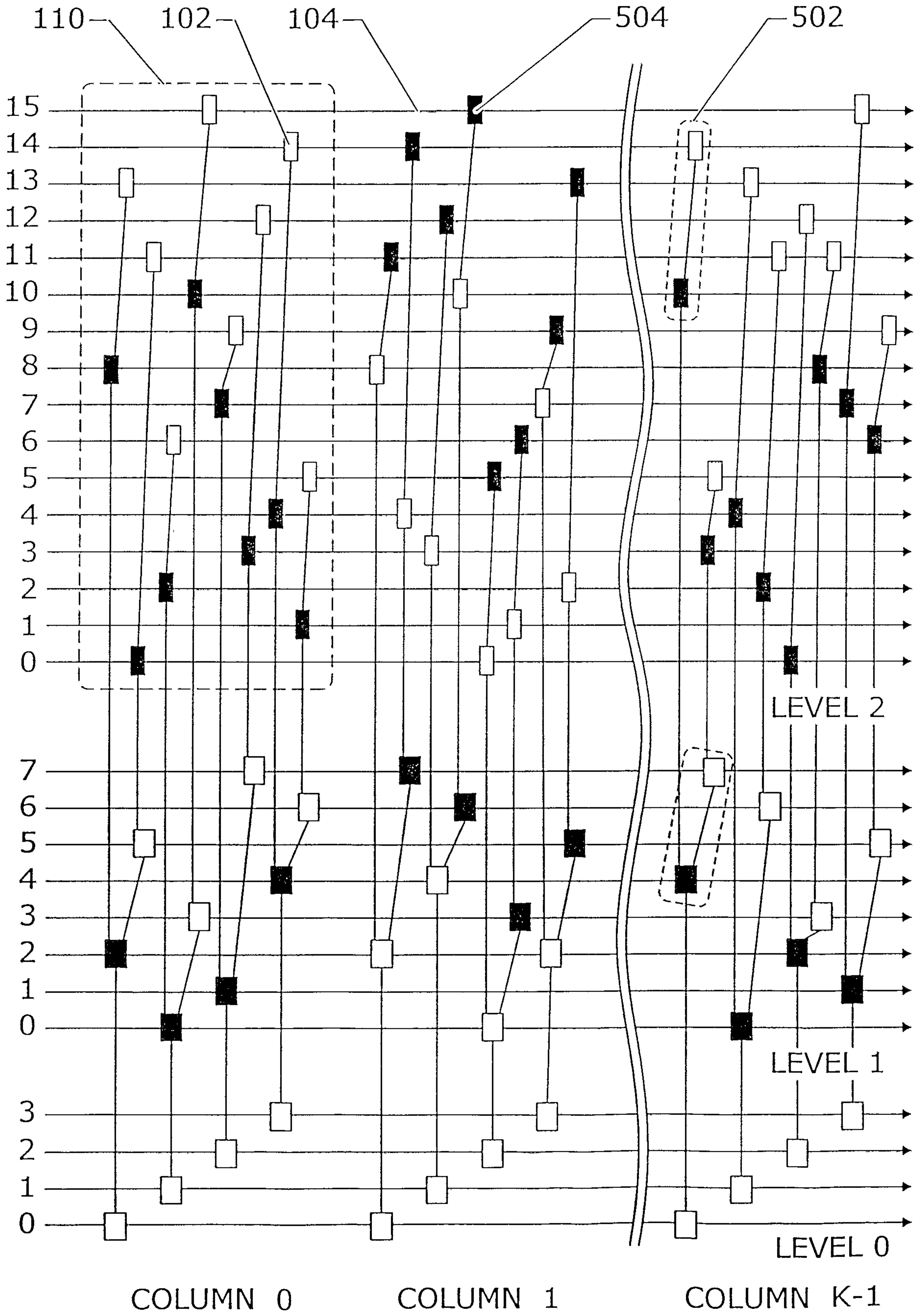

Fig 5

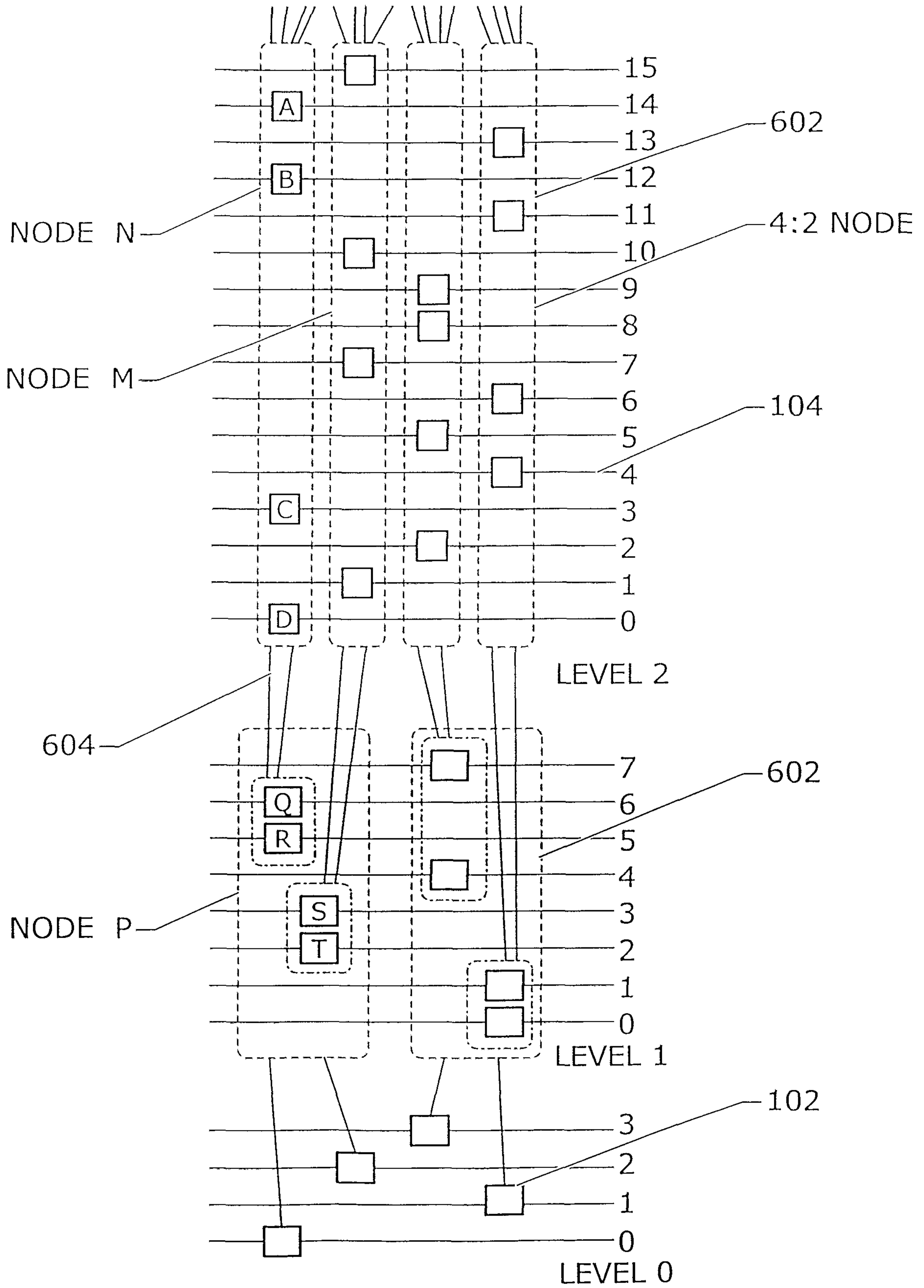

Fig 6A

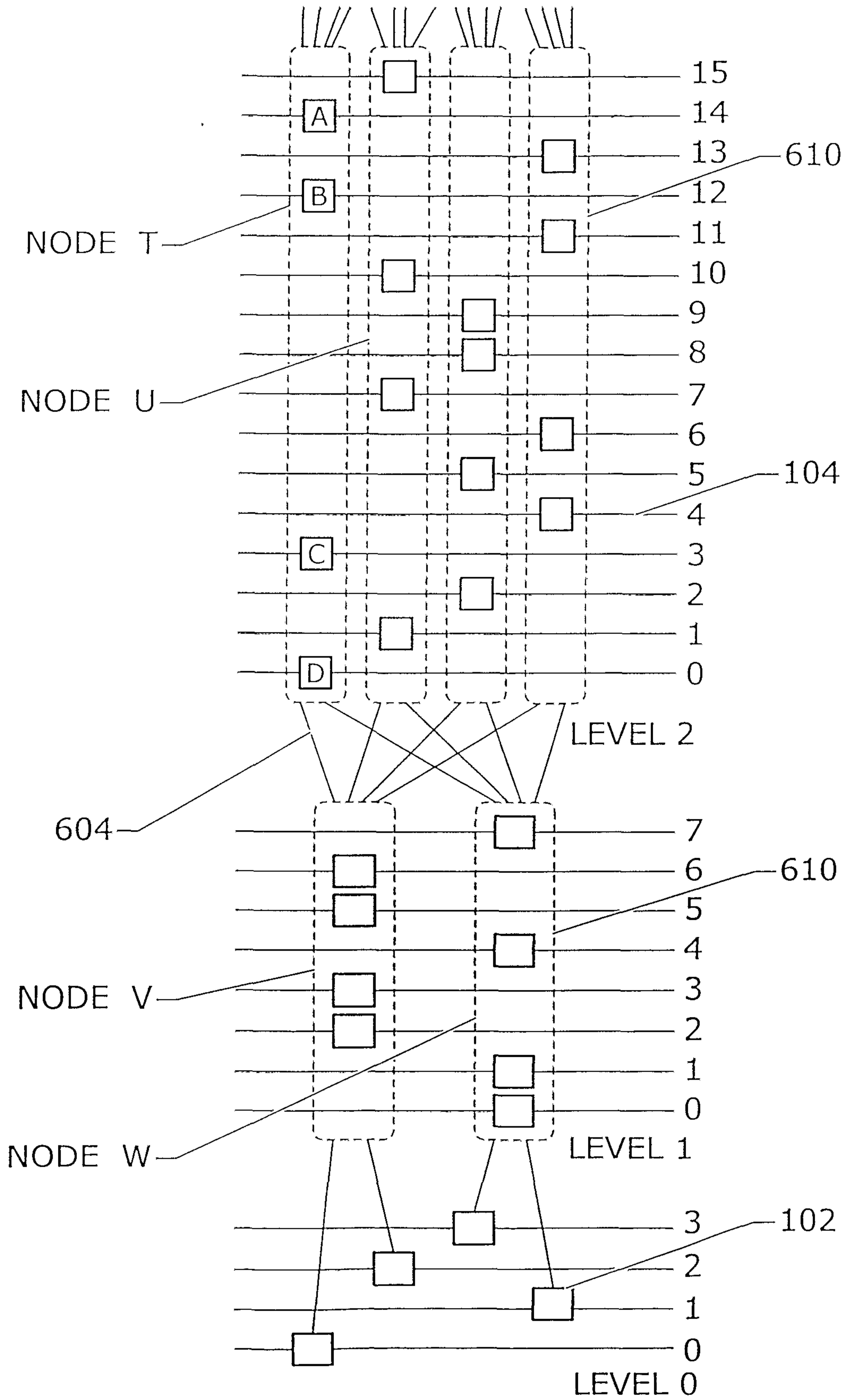

Fig 6B

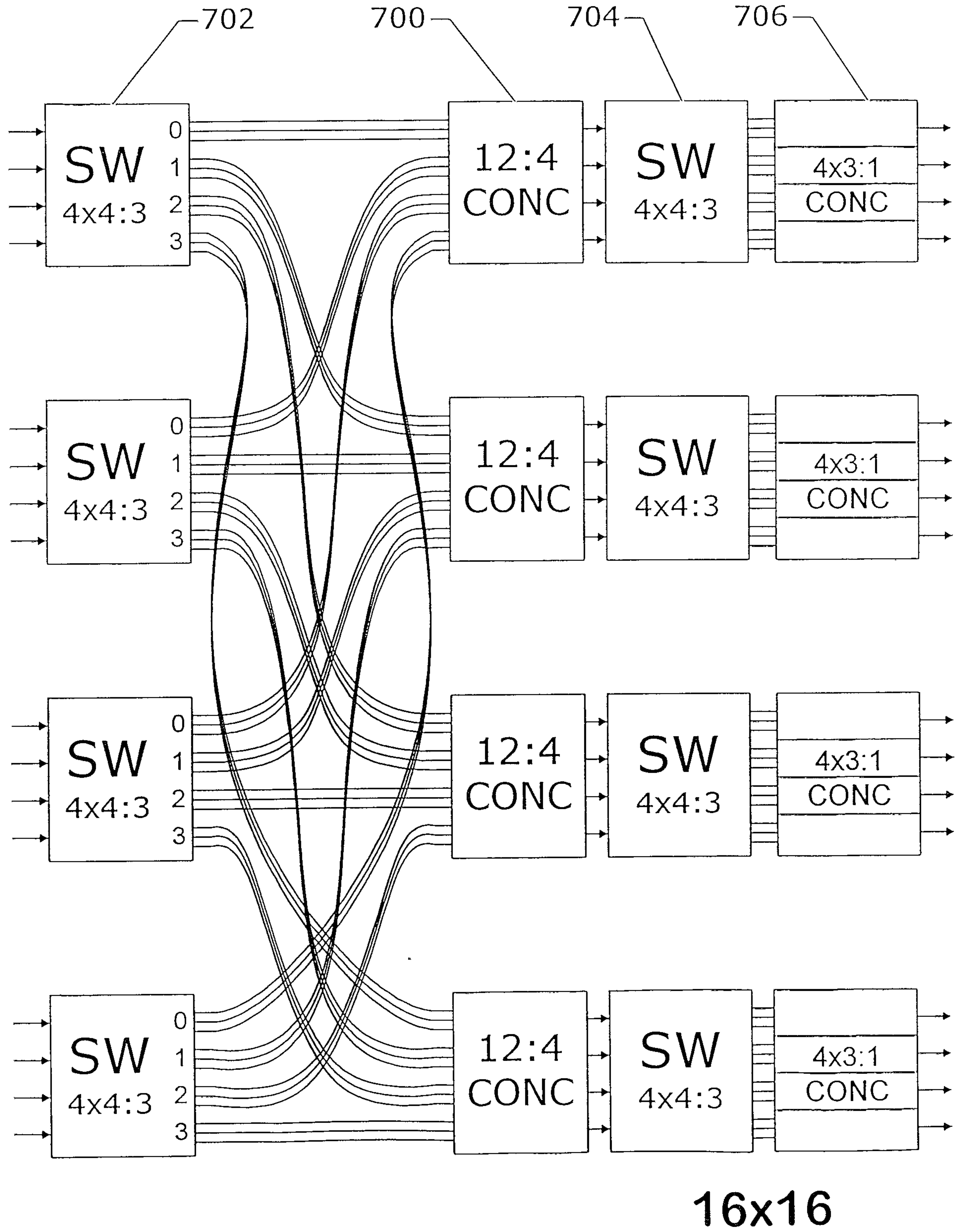
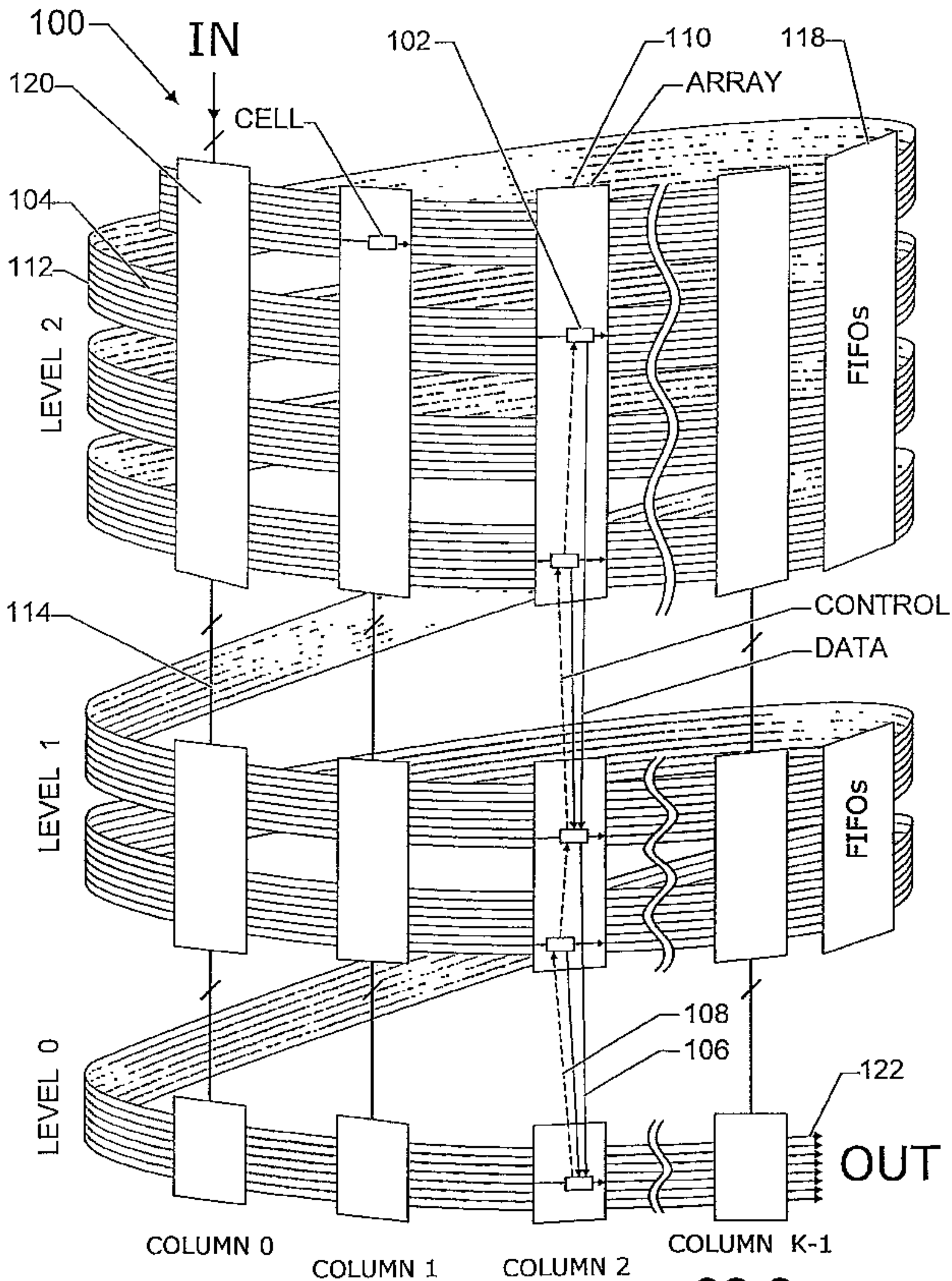

Fig 7



32:8