



(72) CANNON, PETER RICHARD ANDREW, GB

(71) TRELLEBORG AB, SE

(51) Int.Cl.⁶ F16F 1/54

(30) 1998/05/12 (9809996.3) GB

(54) ELEMENT DE MONTAGE ELASTOMERE

(54) ELASTOMERIC MOUNTING

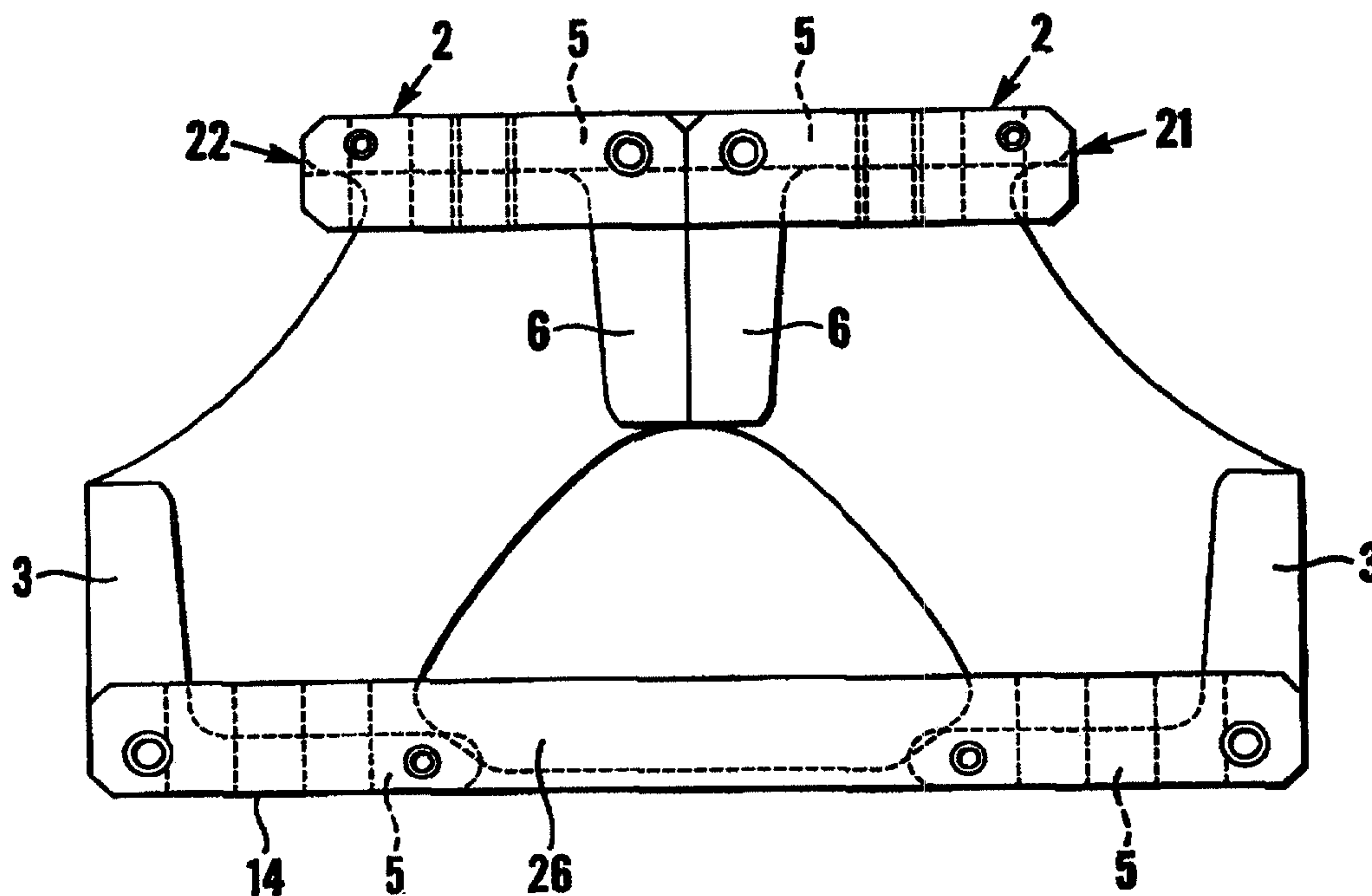

(57) L'invention concerne un module (1) de montage élastomère conçu pour être utilisé avec un second module, les deux module formant un ensemble (20) de montage. Ce module comprend deux éléments (2, 3) terminaux rigides présentant une section en forme de L, et un élément (4) en matériau élastomère qui s'étend entre les des éléments terminaux (10, 11) dirigées vers l'intérieur, et fixé sur ces surfaces, les zones de surface de fixation respectives des deux éléments terminaux rigides étant au moins partiellement décalés par rapport à la direction d'une sollicitation en compression normale et dans une direction transversale perpendiculaire à cette direction de sollicitation.

(57) An elastomeric mounting module (1) suitable for use as one of a pair of modules for forming an elastomeric mounting assembly (20) comprises two rigid end members (2, 3) of L-shape section and an element (4) of elastomeric material extending between and bonded to inwardly facing surfaces (10, 11) of the end members, respective bonded surface zones of the two rigid end members being offset at least in part as considered in the direction of normal compression loading and in a transverse direction perpendicular to said loading direction.



PCT

WORLD INTELLECTUAL PROPERTY ORGANIZATION
International Bureau

INTERNATIONAL APPLICATION PUBLISHED UNDER THE PATENT COOPERATION TREATY (PCT)

(51) International Patent Classification ⁶ : F16F 1/54	A1	(11) International Publication Number: WO 99/58871 (43) International Publication Date: 18 November 1999 (18.11.99)
<p>(21) International Application Number: PCT/GB99/01370</p> <p>(22) International Filing Date: 4 May 1999 (04.05.99)</p> <p>(30) Priority Data: 9809996.3 12 May 1998 (12.05.98) GB</p> <p>(71) Applicant (for all designated States except US): BTR INDUSTRIES LIMITED [GB/GB]; BTR House, Carlisle Place, London SW1P 1BX (GB).</p> <p>(72) Inventor; and (75) Inventor/Applicant (for US only): CANNON, Peter, Richard, Andrew [GB/GB]; 16B Main Street, Fleckney, Leicester LE8 8AN (GB).</p> <p>(74) Agent: BADGER, John, Raymond; BTR Group Intellectual Property, Knights House, 2 Parade, Sutton Coldfield, West Midlands B72 1PH (GB).</p>	<p>(81) Designated States: AL, AM, AT, AU, AZ, BA, BB, BG, BR, BY, CA, CH, CN, CU, CZ, DE, DE (Utility model), DK, EE, ES, FI, GB, GD, GE, GH, GM, HR, HU, ID, IL, IN, IS, JP, KE, KG, KP, KR, KZ, LC, LK, LR, LS, LT, LU, LV, MD, MG, MK, MN, MW, MX, NO, NZ, PL, PT, RO, RU, SD, SE, SG, SI, SK, SL, TJ, TM, TR, TT, UA, UG, US, UZ, VN, YU, ZA, ZW, ARIPO patent (GH, GM, KE, LS, MW, SD, SL, SZ, UG, ZW), Eurasian patent (AM, AZ, BY, KG, KZ, MD, RU, TJ, TM), European patent (AT, BE, CH, CY, DE, DK, ES, FI, FR, GB, GR, IE, IT, LU, MC, NL, PT, SE), OAPI patent (BF, BJ, CF, CG, CI, CM, GA, GN, GW, ML, MR, NE, SN, TD, TG).</p> <p>Published <i>With international search report. Before the expiration of the time limit for amending the claims and to be republished in the event of the receipt of amendments.</i></p>	

(54) Title: ELASTOMERIC MOUNTING

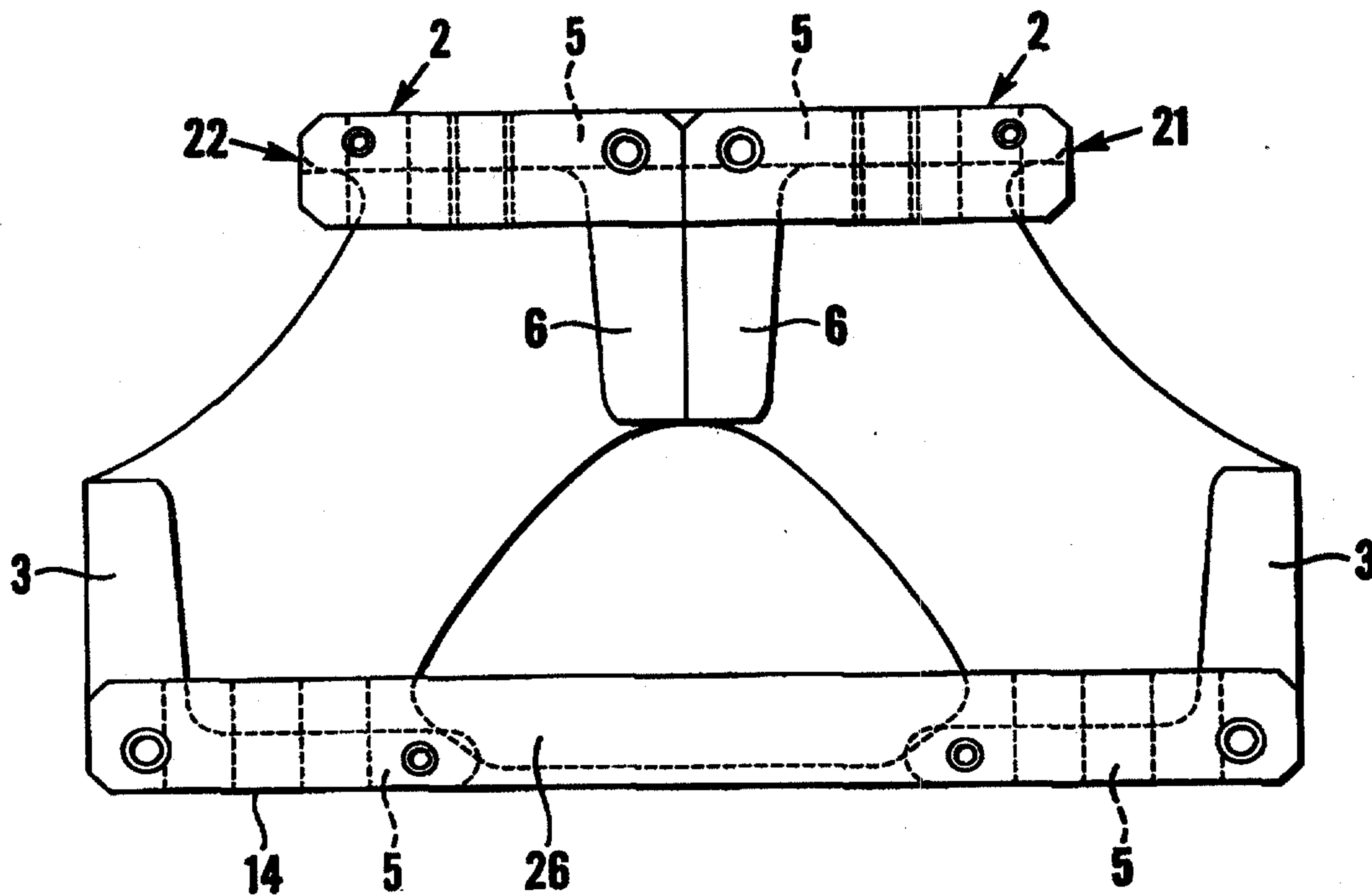

(57) Abstract

An elastomeric mounting module (1) suitable for use as one of a pair of modules for forming an elastomeric mounting assembly (20) comprises two rigid end members (2, 3) of L-shape section and an element (4) of elastomeric material extending between and bonded to inwardly facing surfaces (10, 11) of the end members, respective bonded surface zones of the two rigid end members being offset at least in part as considered in the direction of normal compression loading and in a transverse direction perpendicular to said loading direction.

WO 99/58871

PCT/GB99/01370

"ELASTOMERIC MOUNTING"

This invention relates to an elastomeric mounting and in particular, though not exclusively, to an elastomeric mounting adapted to accommodate a high degree of deflection in a direction of normal compression loading.

It relates also, though not exclusively, to an elastomeric mounting which preferably allows relatively unrestricted movement in at least one direction in a plane perpendicular to the direction of normal compression loading.

The invention has as one object the provision of an elastomeric mounting which has an improved compression deflection capability and which potentially is of lower cost than established designs of mountings. Preferably the elastomeric mounting is effective also to dampen the transmission of acoustic frequency vibrations.

According to one aspect of the invention an elastomeric mounting module comprises two rigid end members, each end member being substantially of L-shape in cross-section and orientated with two inwardly facing surfaces of the L-shape generally facing towards inwardly facing surfaces of the other end member, and an element of elastomeric material extending between and bonded to said inwardly facing surfaces, respective bonded surfaces of said end members being offset at least in part as considered in the direction of normal compression loading and in a transverse direction perpendicular to said loading direction.

It is envisaged that preferably the two inwardly facing, bonded surfaces of an end member will lie relative to one another at an angle in the range 80° to 115° , more preferably in the range 85° to 100° . The bonded surfaces of each end member may lie in planes substantially perpendicular relative to one another.

The two end members may be identical, so helping to minimise production costs.

Preferably the respective bonded surfaces are partly overlapped as viewed along said direction of normal compression loading. Viewed in a first transverse direction perpendicular to the compression loading direction said

bonded surfaces preferably are spaced apart, at least in the absence of compression loading. Viewed in a second transverse direction perpendicular to said first transverse direction the elastomeric element preferably is substantially free from direct compression loading at least at normal operating loads.

The relative shapes of the module parts and their sizes preferably are selected so that during initial loading in said direction of compression the elastomeric element is loaded in shear and compression, in combination.

The elastomeric element preferably is bereft of any internal reinforcement or interleaves. Preferably in at least one transverse direction it is free from either internal or external structure that might inhibit its freedom to bulge, at least until any buffer action occurs under extreme or shock load conditions.

Preferably, but not necessarily, the elastomeric element is of a substantially solid shape. Preferably it is bereft of cavities, and more preferably it is bereft of any openings extending therethrough in a direction perpendicular to the cross-sectional plane of said L shape.

Preferably the elastomeric material extends wholly into the corner space region between the two inwardly facing surfaces of an end member. It is believed that this usefully assists in deadening the transmission of sound through the mounting.

Unbonded end surfaces of the rigid members may be provided with location means, such as tapped holes, to allow rigid members of one module to be located relative to corresponding rigid members of a second module.

Tie bars may be provided one to secure one pair of end members in proximity to one another, e.g. in direct back-to-back contact, and another to secure the other pair at a prescribed spacing.

The invention provides also an elastomeric mounting assembly which is comprised by two or more elastomeric mounting modules secured in position relative to one another. The assembly may be secured to supported or

supporting structure which is utilised to maintain rigid members of the modules in a predetermined spatial relationship.

The assembly may comprise modules having elastomeric elements of different sizes and/or of different volumes. Preferably none of the elastomeric elements of the assembly have a volume greater than 15 litres.

Preferably the same cross-sectional size and shape of rigid end member is used in two or more modules of different sizes or which have elastomeric elements of different volumes.

Embodiments of the invention are now described by way of example with reference to the accompanying Drawings wherein:

Figures 1 to 3 show end, side and top views of a mounting module of the invention,

Figures 4 to 6 show end, side and top views of a mounting assembly of the invention,

Figures 7 & 8 show side and top views of another mounting assembly of the invention,

Figures 9 & 10 show side and top views of yet another assembly of the invention,

Figure 11 shows a vertical load-deflection curve, and

Figure 12 shows end views of five design variations each unloaded and fully loaded vertically.

A modular type elastomeric mounting 1 shown in Figures 1 to 3 comprises two identical rigid, metal end members 2, 3 bonded to and interconnected by an elastomeric element 4.

Each end member 2, 3 has a right angled L shape in cross section as shown in Figure 1 and has two limb portions 5, 6 of equal length.

One limb 5 is of uniform thickness. The other limb 6 is slightly tapered, to reduce in thickness away from a corner region 7.

Outer faces 8, 9 of the limbs 5, 6 are at right angles.

The elastomeric element 4 extends generally diagonally between the inwardly facing end member surfaces 10, 11 to which it is bonded, as viewed in Figure 1. Element 4 is bonded to substantially the whole of each face 10, 11 and to the far end surface 12 of each tapered limb 6. Element 4 therefore fully occupies the corner space region 18 between the two inwardly facing surfaces 10,11 of each end member.

The diagonal length of the elastomeric element 4 is sufficient to vertically space apart the end surfaces 12 of the tapered limbs 6 as shown by distance X of Figure 1. This ensures that when the limbs 6 move transversely towards one another the elastomeric element is loaded primarily only in shear at least during the initial stages of that movement.

The diagonal length and shape of the elastomeric element is selected to create a part overlap of the horizontal limbs 5 when viewed in a vertical direction and as shown by the distance Y of Figure 1.

The outer faces 8 of the limbs 5 are provided with plain holes 14 for attachment to supporting or supported structure.

The end faces 17 of the end members 2, 3 also have tapped and plain holes 15, 16 for a purpose described below in the context of an elastomeric mounting assembly which comprises a plurality of the modular mountings 1.

An elastomeric mounting assembly 20 shown in Figures 4 to 6 comprises four of the modular mountings 1 of Figures 1 to 3. The four mountings 21-24 are positioned in pairs, the two pairs lying side-by-side with end members 2,3 aligned, and the two mountings of each pair being in a back-to-back configuration with a pair of tapered limbs 6 of upper end members 2 adjacent one another and the associated limbs 5 being co-planar.

Limbs 6 of a back-to-back pair of adjacent upper end members 2 are held together by an upper end tie bar 25 and a pin which extends through the bar into the holes 15,16. Limbs 5 of lower end members 3 similarly are maintained spaced by a lower tie bar 26.

The two back-to-back pairs of mountings 21-24 are held in alignment by dowel pins 27 in confronting end faces 17 of the end members 2,3. Axial

separation of the pairs of mountings is resisted by the supported and supporting structure to which the mountings are secured with the aid of the plain holes 14.

Inwardly facing surfaces 28 of the upper and lower tie bars 25,26 are curved to provide preferential resistance to bulging movement of the elastomeric elements. The curvature is selected in relation to desired load-deflection characteristics of the mounting assembly at conditions under which the elastomer bulges axially, which is sideways as viewed in Figure 5.

Figures 7 and 8 show a variation of the construction of Figures 4 to 6. Intermediate tie bars 30,31 are positioned between the pairs of mountings 21-24. The tie bars 30,31 have curved buffer surfaces 32,33 shaped to aid tuning of the mounting to the desired load-deflection characteristics.

Figures 9 and 10 show another variation of the construction of Figures 4 to 6. This variation has an additional pair 35,36 of mounting modules provided between the two pairs of mountings 21-24. The axial length of the mountings 35,36, as viewed in the horizontal direction of the Figures, is less than that of the mountings 21-24.

Figure 11 shows a sample of a vertical load-deflection curve for the mountings of the invention. The initial stage relates to vertical shear and compression loading. The bulge stage relates to axial, longitudinal extension (side to side direction of Figure 2) and in the buffer stage the elastomeric material at one module presses against the elastomeric elements of neighbouring modules and any axial buffer surfaces of the tie bars.

Figure 12 shows a selection of design alternatives each in unloaded and fully loaded states. Alternatives 12c and 12d have a longitudinally continuous space 40 between the lower end members 41. This allows the mounting to collapse further under vertical load than is possible with the other design alternatives.

CLAIMS:

1. An elastomeric mounting module (1) comprising two rigid end members (2,3), each substantially of L-shape in cross-section and an element (4) of elastomeric material extending therebetween and bonded thereto said end members (2,3) having respective bonded surfaces (10,11) which are offset (y,x) at least in part as considered in the direction of normal compression loading and relative to a transverse direction perpendicular to said loading direction, characterised in that each end member (2,3) is orientated with the two inwardly facing, bonded surfaces (10,11) thereof generally facing towards inwardly facing surfaces (10,11) of the other end member.
2. A mounting module in accordance with claim 1, characterised in that said two inwardly facing surfaces (10,11) of an end member (2,3) lie at an angle in the range 80° to 115° relative to one another as considered in the cross-section of said L shape.
3. A mounting module in accordance with claim 1 or claim 2, characterised in that said angle is in the range 85° to 100° .
4. A mounting module in accordance with any one of the preceding claims, characterised in that said bonded surfaces (10,11) of each end member lie in planes substantially perpendicular relative to one another.
5. A mounting module in accordance with any one of the preceding claims, characterised in that said two rigid end members (2,3) are identical.
6. A mounting module in accordance with any one of the preceding claims, characterised in that said respective bonded surfaces (10,11) are partly overlapped (y) as viewed along said direction of normal compression loading.
7. A mounting module in accordance with any one of the preceding claims, characterised in that said bonded surfaces (10,11) are spaced apart (x), in the absence of compression load, when viewed in a first transverse direction perpendicular to the compression loading direction.
8. A mounting module in accordance with claim 7, characterised in that when viewed in a second transverse direction perpendicular to said first

transverse direction the elastomeric element (4) is substantially free from direct compression loading at normal operating loads.

9. A mounting module in accordance with any one of the preceding claims, characterised in that during initial loading in said direction of compression the elastomeric element (4) is subject to a combination of shear and compression.

10. A mounting module in accordance with any one of the preceding claims, characterised in that the elastomeric element (4) is bereft of internal reinforcement or interleaves.

11. A mounting module in accordance with any one of the preceding claims, characterised in that in at least one transverse direction the elastomeric element (4) is free from additional internal or external structure that might inhibit the freedom of the material to bulge during normal working load conditions.

12. A mounting module in accordance with any one of the preceding claims, characterised in that the elastomeric element (4) is of a substantially solid shape.

13. A mounting module in accordance with any one of the preceding claims, characterised in that the elastomeric element (4) is bereft of cavities therein.

14. A mounting module in accordance with any one of the preceding claims, characterised in that the elastomeric element (4) is bereft of any openings extending therethrough in a direction perpendicular to the cross-sectional plane of said L shape.

15. A mounting module in accordance with any one of the preceding claims, characterised in that unbonded end surfaces (17) of the rigid members (2,3) comprise location means (15,16) whereby said rigid members (2,3) of the module may be located relative to corresponding rigid members of another module.

16. A mounting module in accordance with any one of the preceding claims characterised in that it comprises tie bars (25,26) whereby one pair of respective end members (2) of two modules (1) may be secured in proximity to one another and the other pair of respective end members (3) may be secured at a prescribed spacing relative to one another.

17. An elastomeric mounting assembly characterised in that it comprises at least two elastomeric mounting modules (1) in accordance with any one of the preceding claims and secured in position relative to one another.

18. An elastomeric mounting assembly in accordance with claim 17 characterised in that supported or supporting structure is utilized to maintain rigid members of the modules in a predetermined spatial relationship.

19. An elastomeric mounting assembly in accordance with claim 17 or claim 18, and characterised in that it comprises at least two modules (1) having elastomeric elements (21-24; 35,36) of different sizes.

20. An elastomeric mounting assembly in accordance with any one of claims 17 to 19, characterised in that it comprises at least two modules (1) having elastomeric elements (21-24; 35,36) of different volumes.

21. An elastomeric mounting assembly in accordance with any one of claims 17 to 20, characterised in that none of the elastomeric elements has a volume greater than 15 litres.

22. An elastomeric mounting assembly in accordance with any one of claims 17 to 21, characterised in that the same size and shape of rigid end member is used in two modules of different sizes.

23. An elastomeric mounting assembly in accordance with any one of claims 17 to 22, characterised in that the same size and shape of rigid end member is used in two modules which have elastomeric elements of different volumes.

1/7

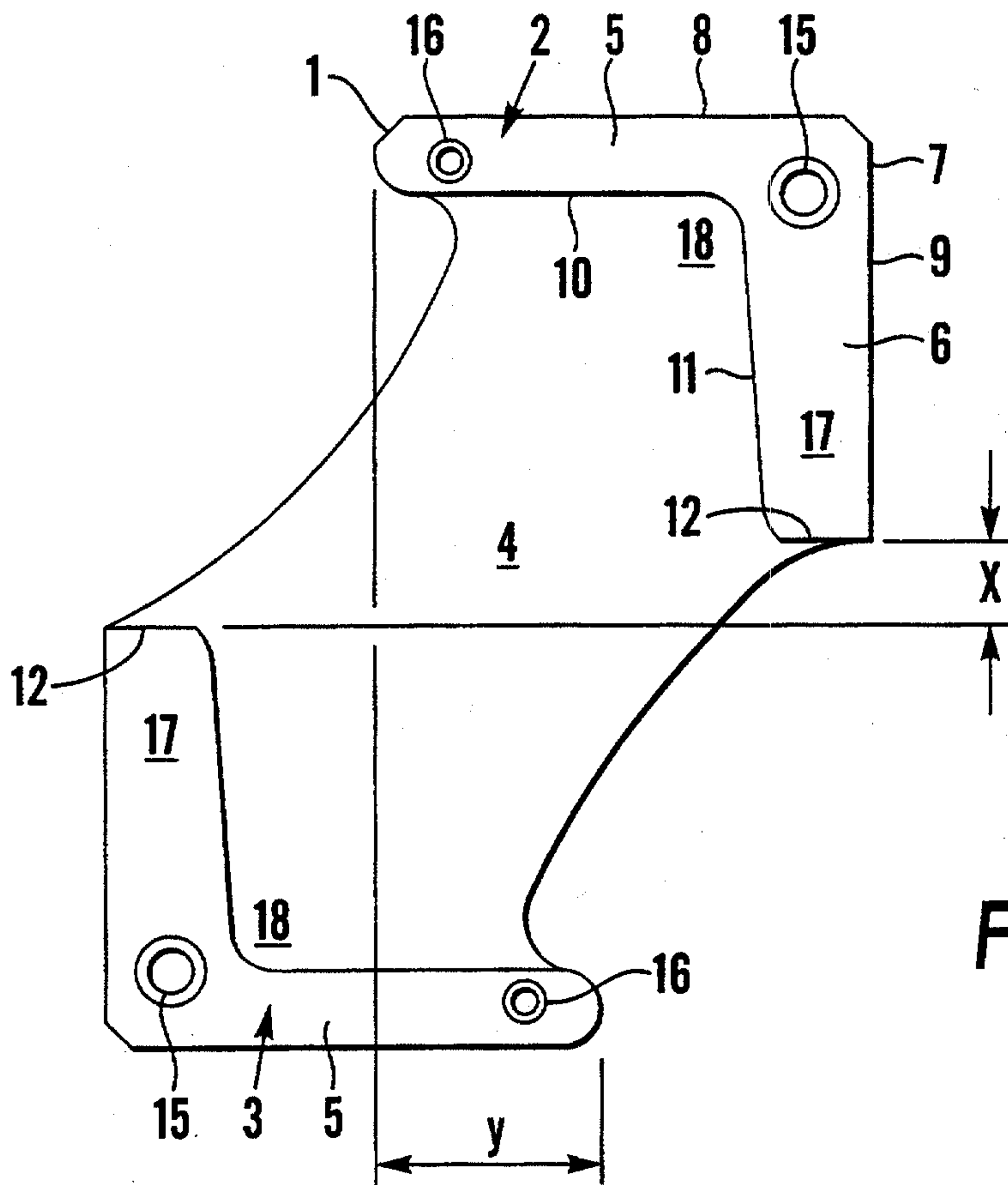

Fig. 1

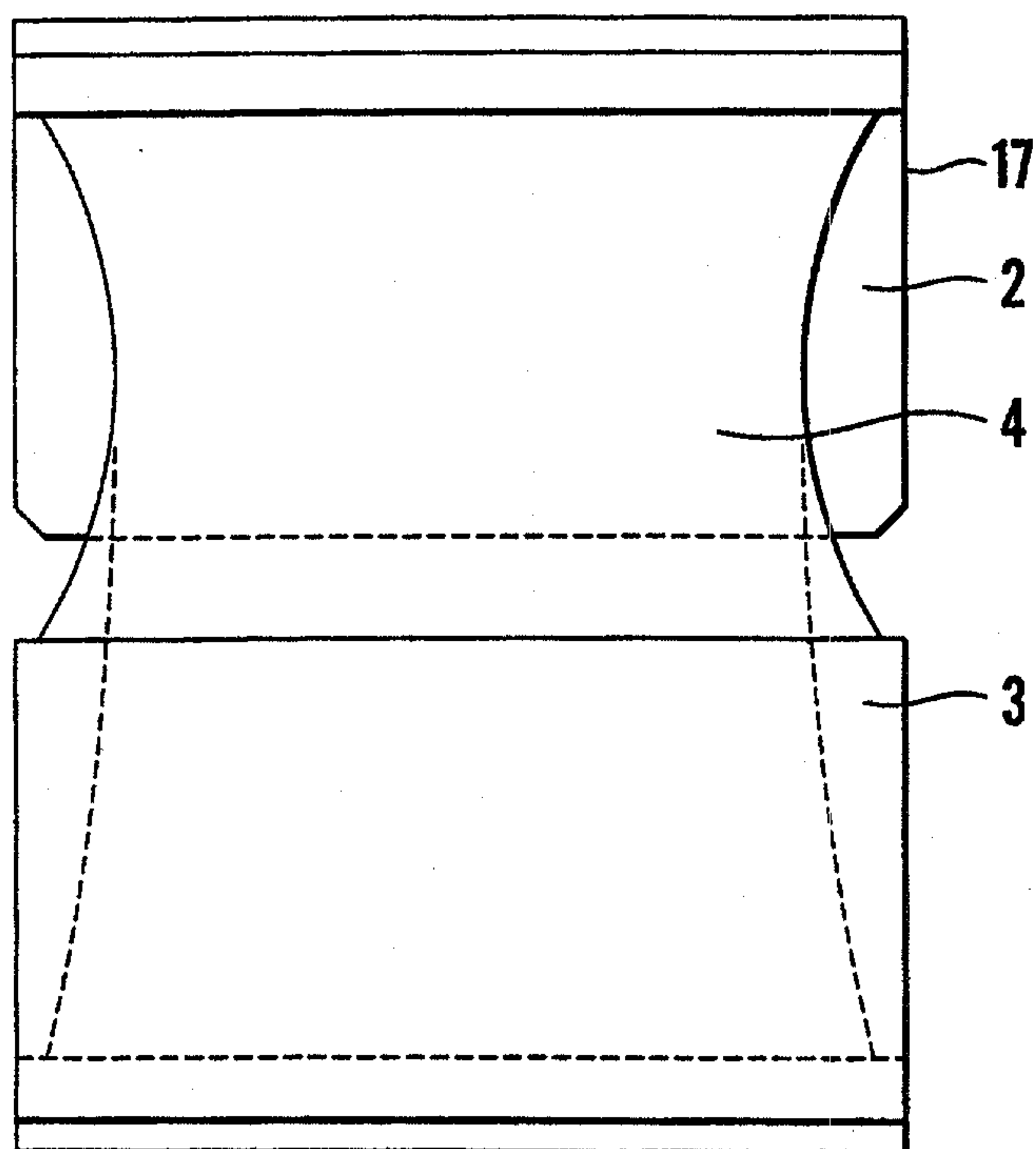

Fig. 2

2/7

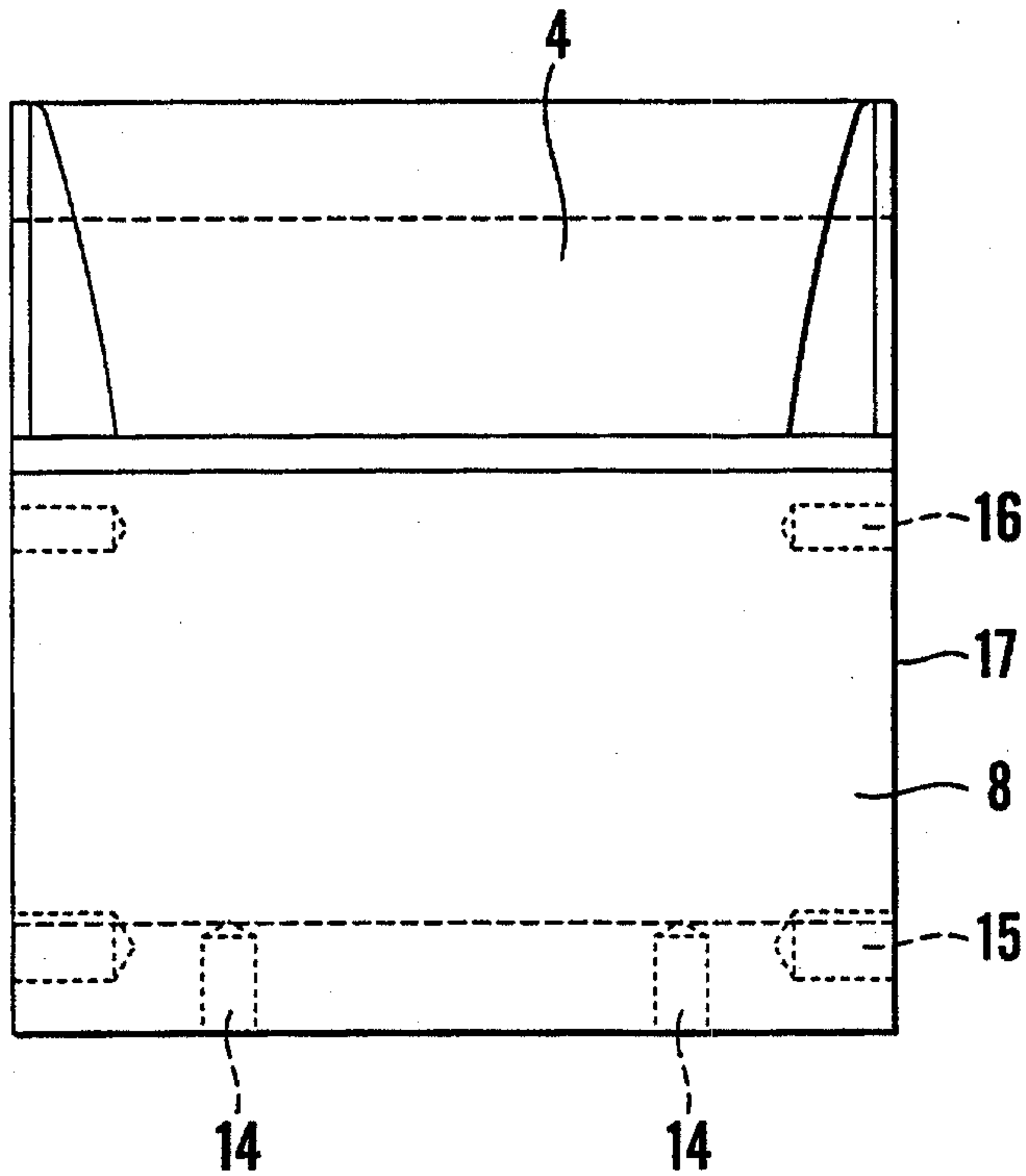

Fig.3

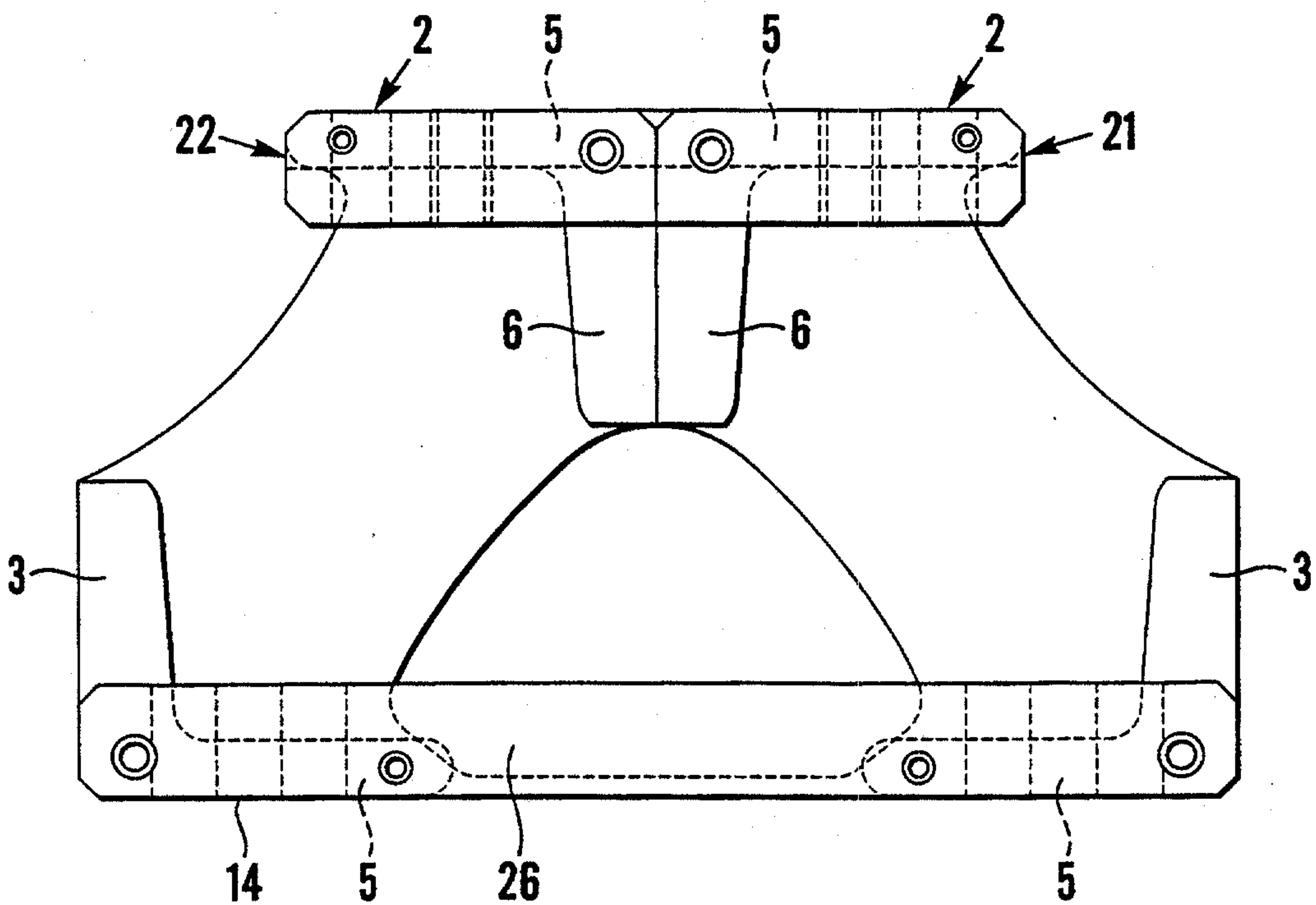

Fig.4

3/7

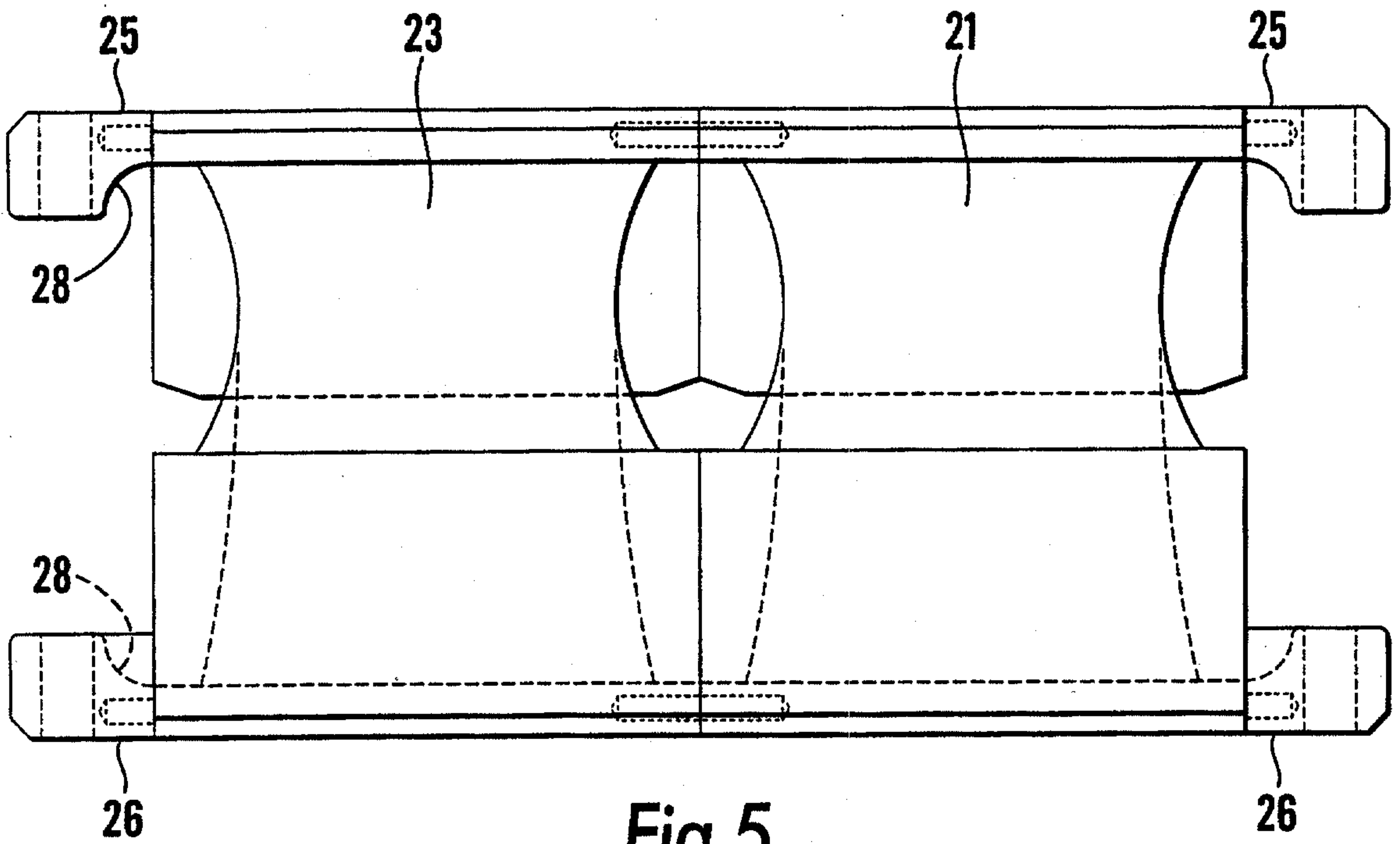

Fig. 5

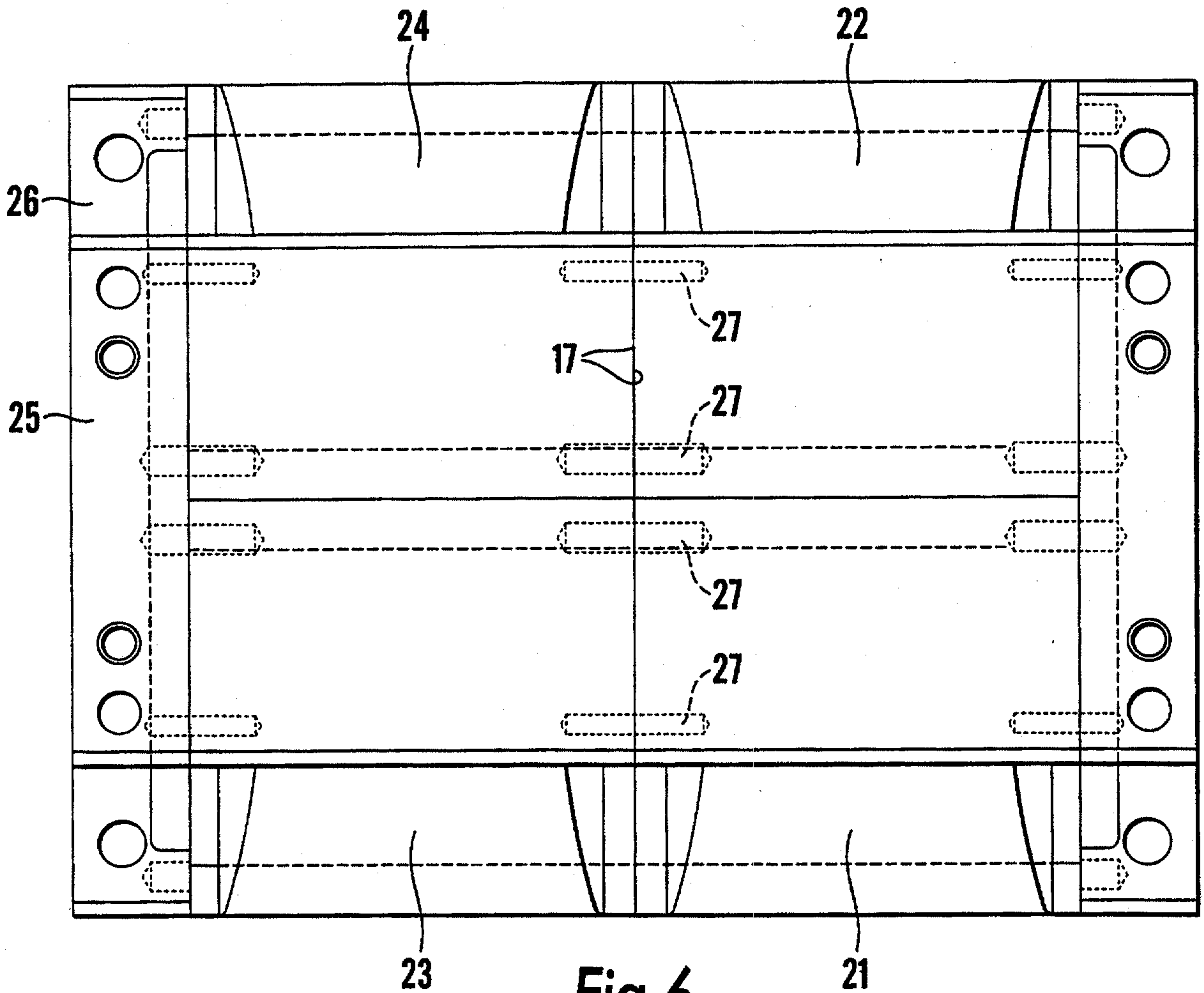

Fig. 6

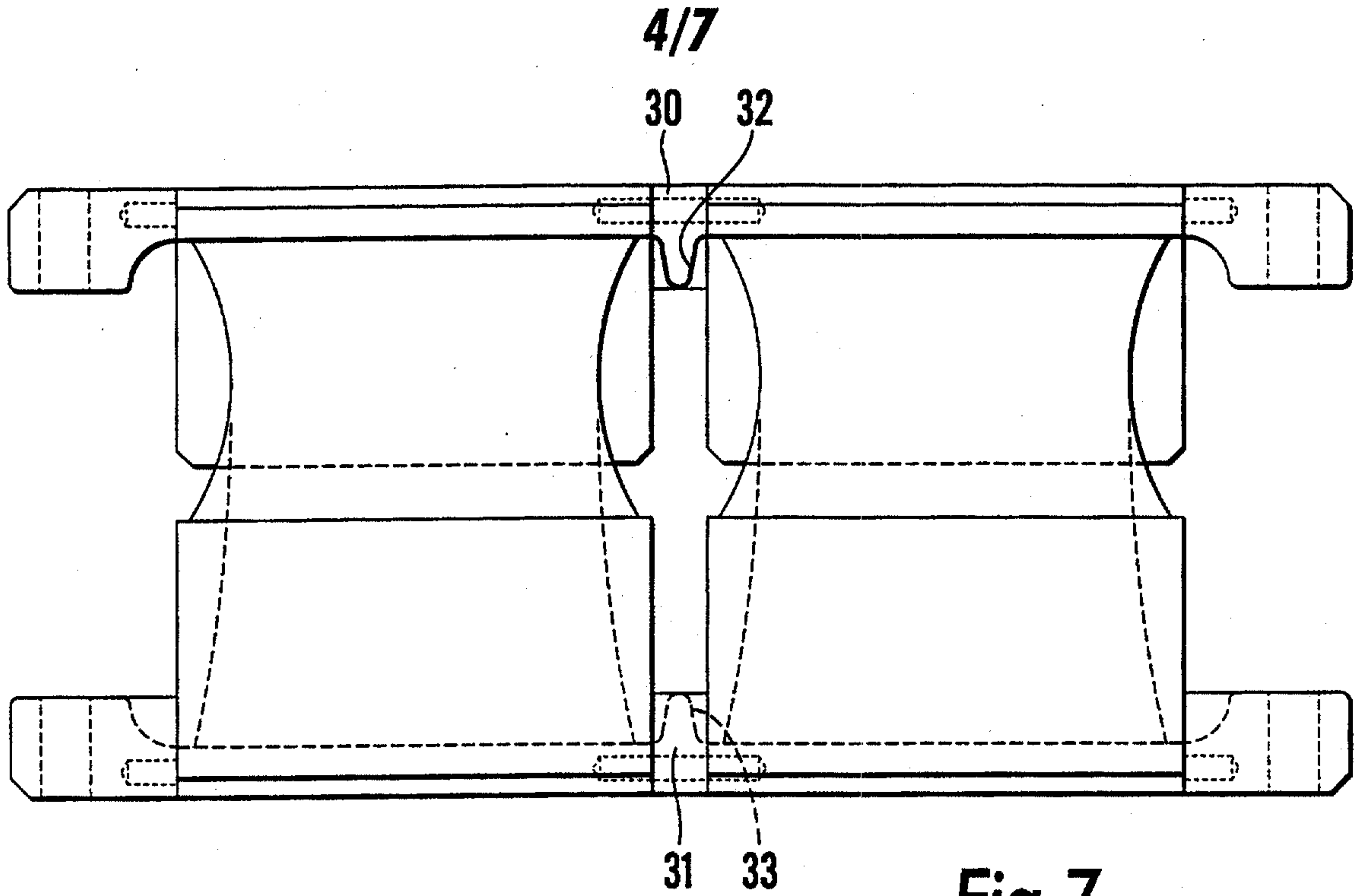

Fig.7

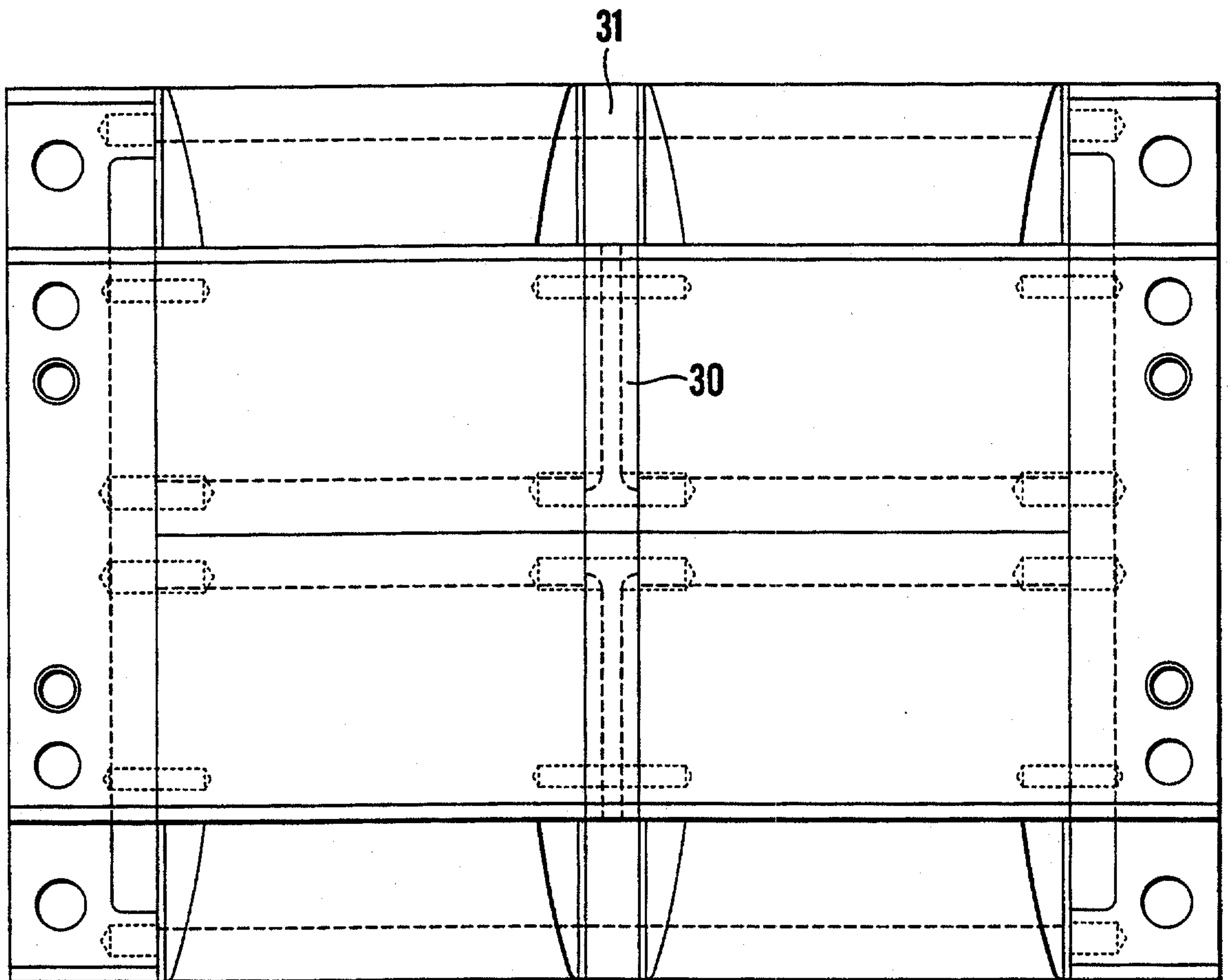

Fig.8

5/7

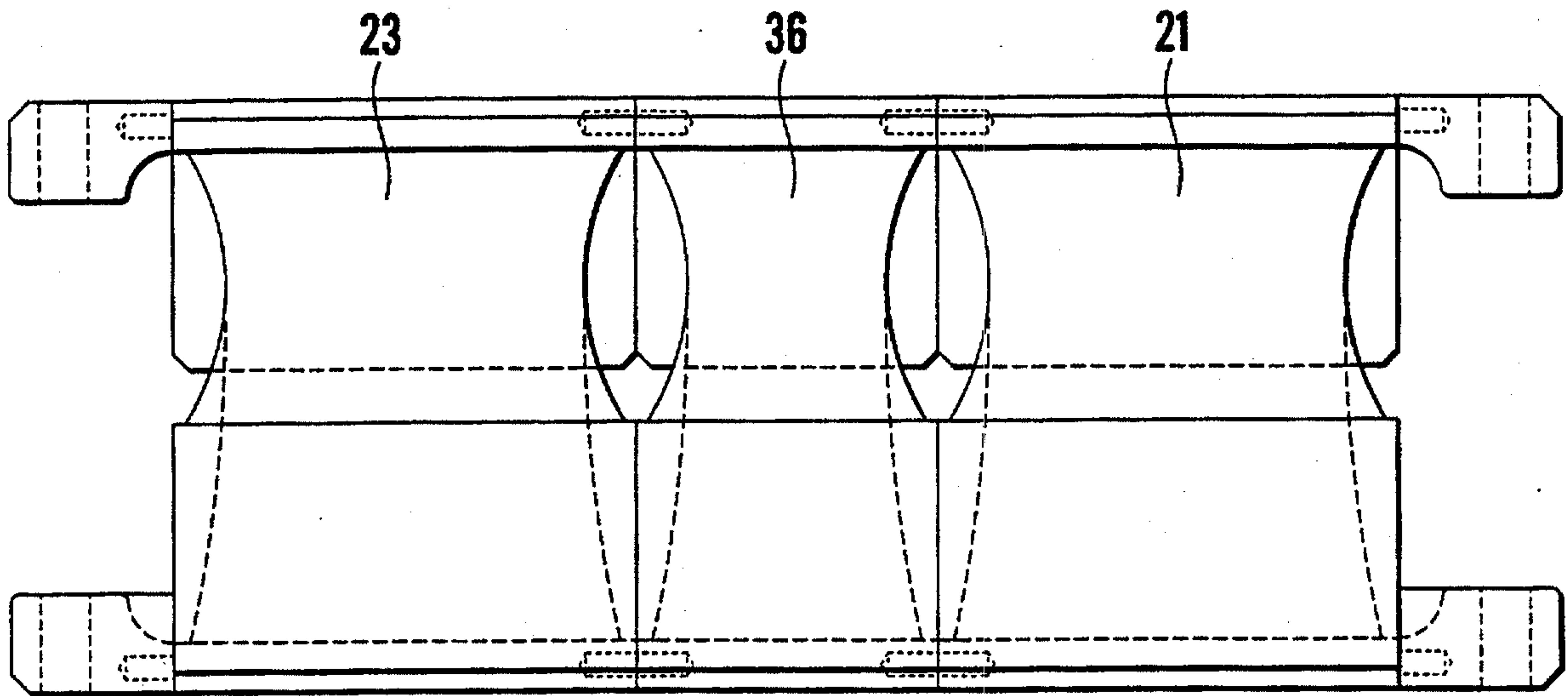

Fig. 9

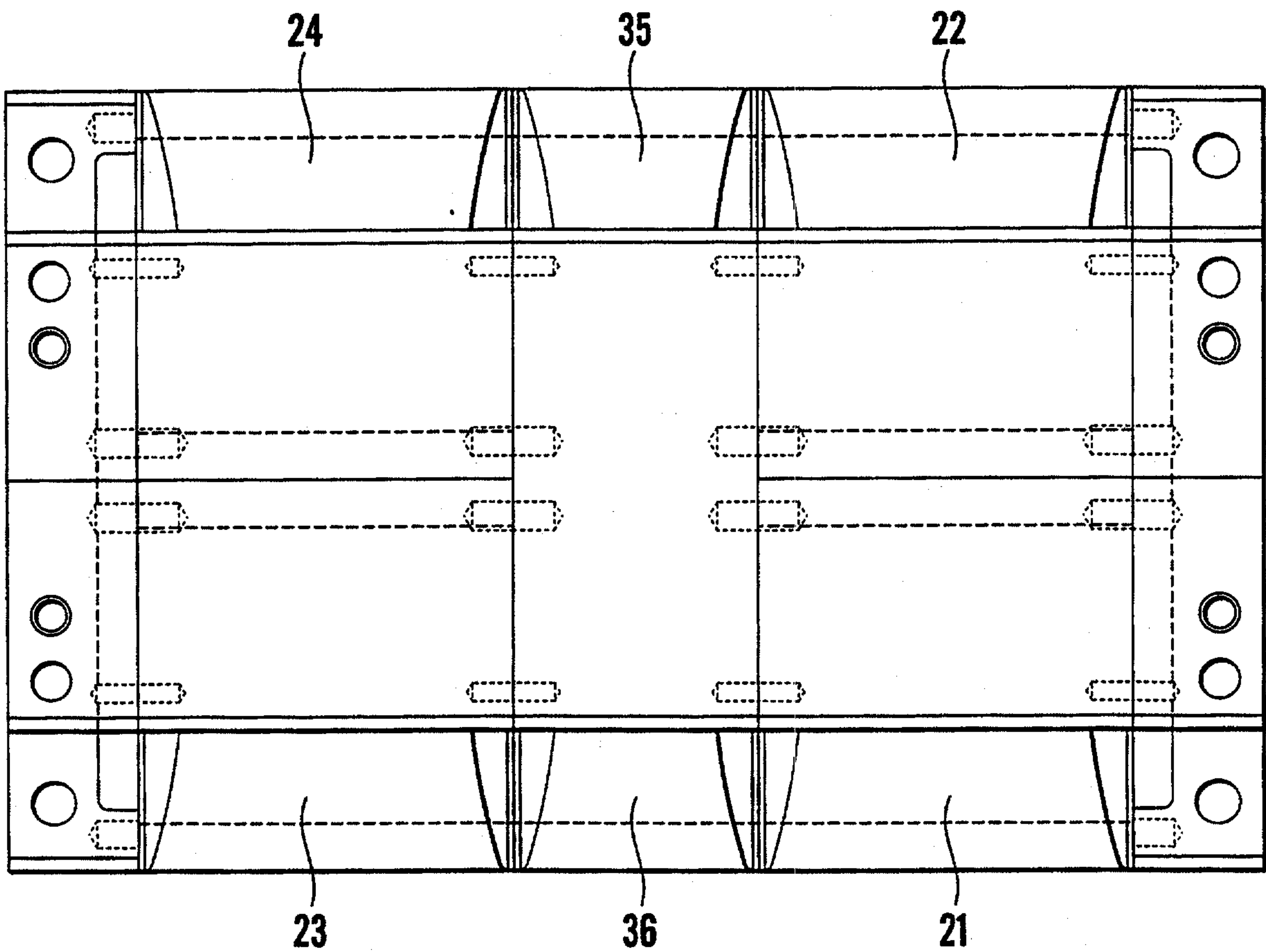

Fig. 10

STIFFNESS CHARACTERISTICS

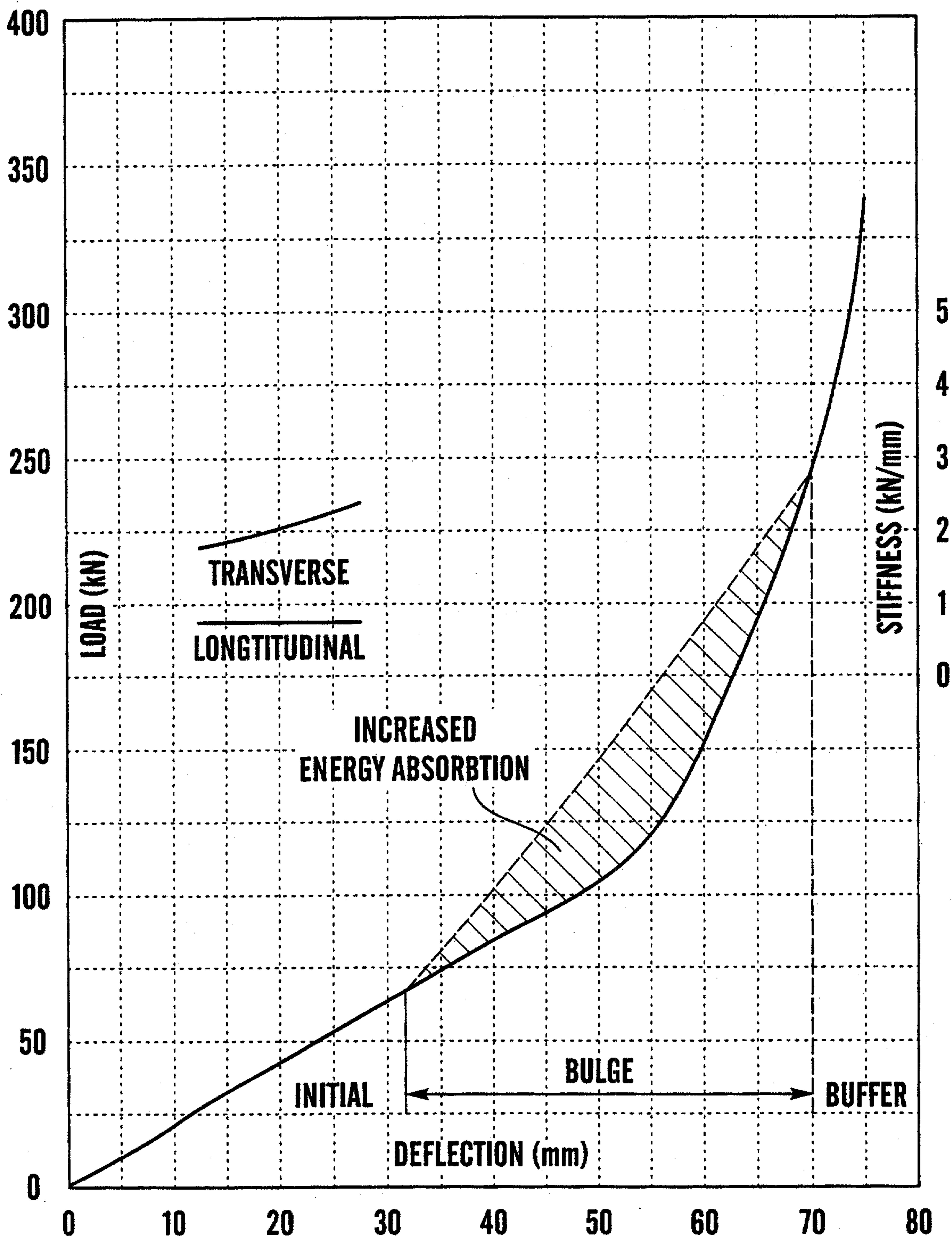

Fig. 11

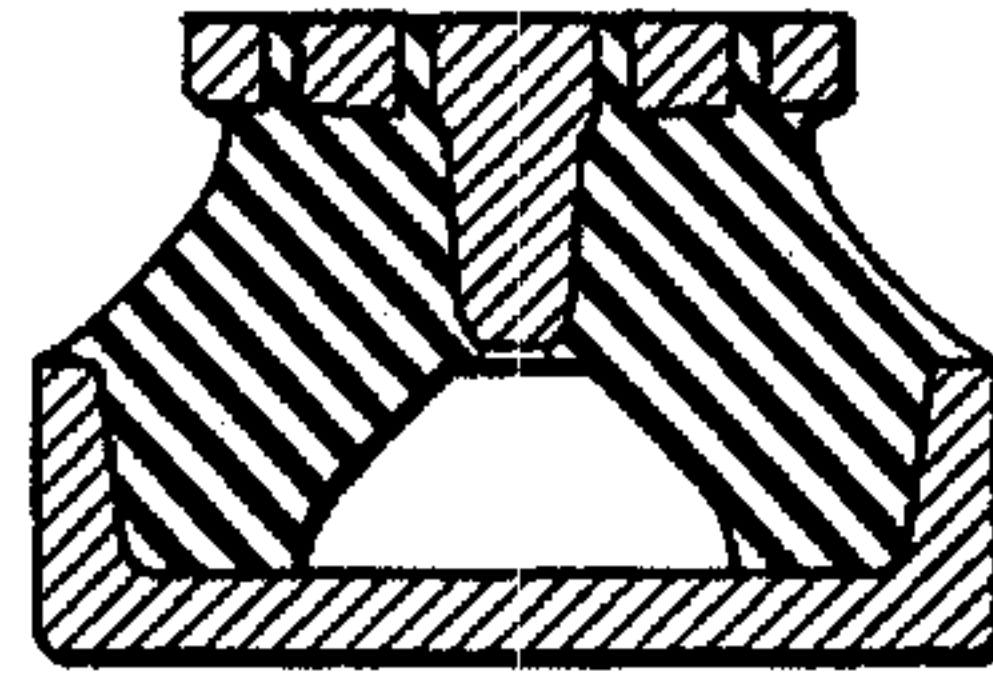
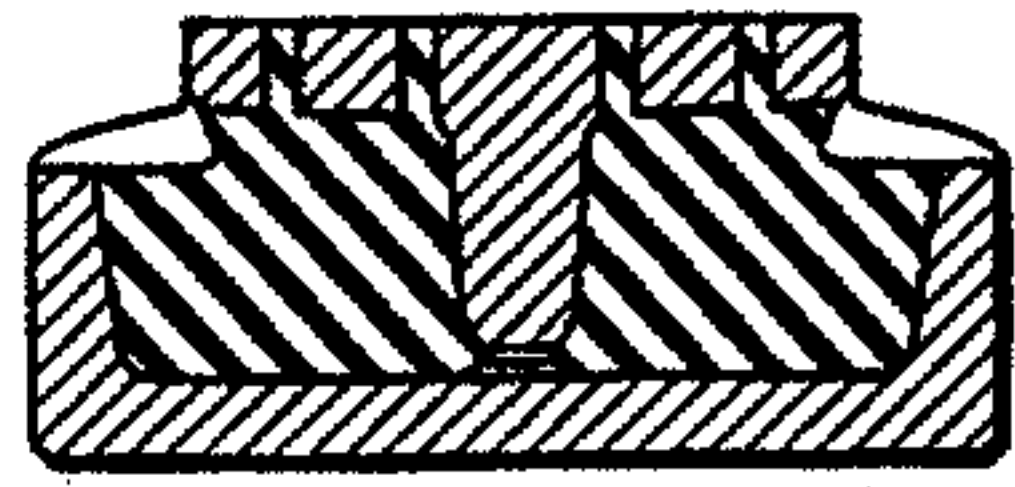

Fig. 12a

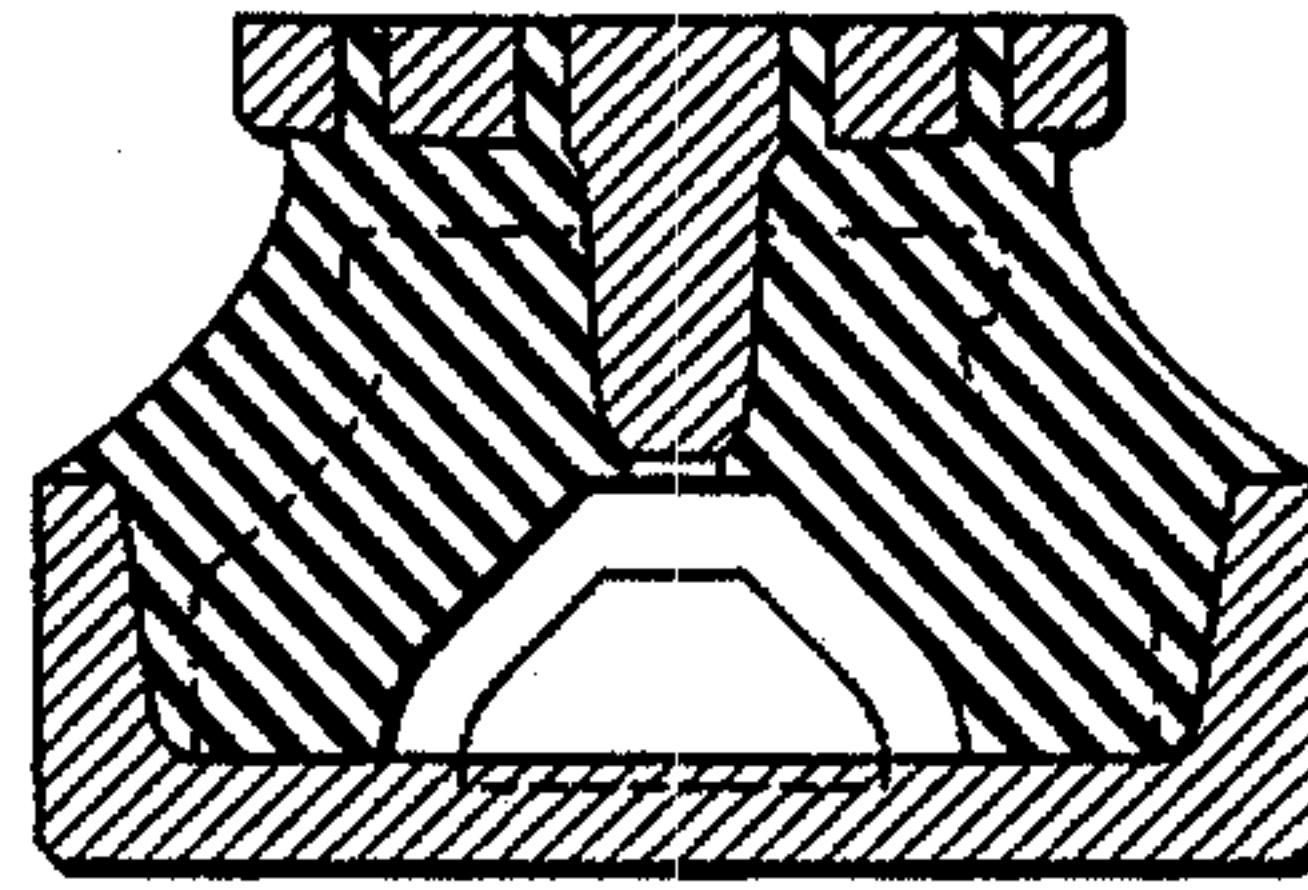
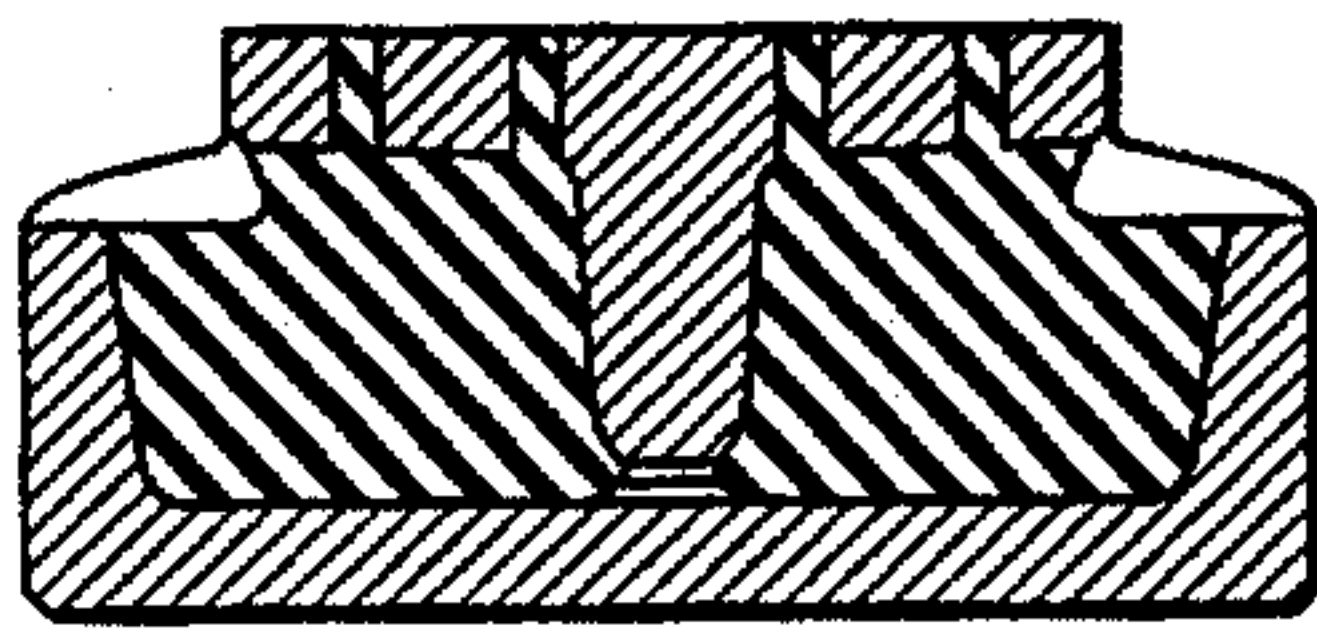

Fig. 12b

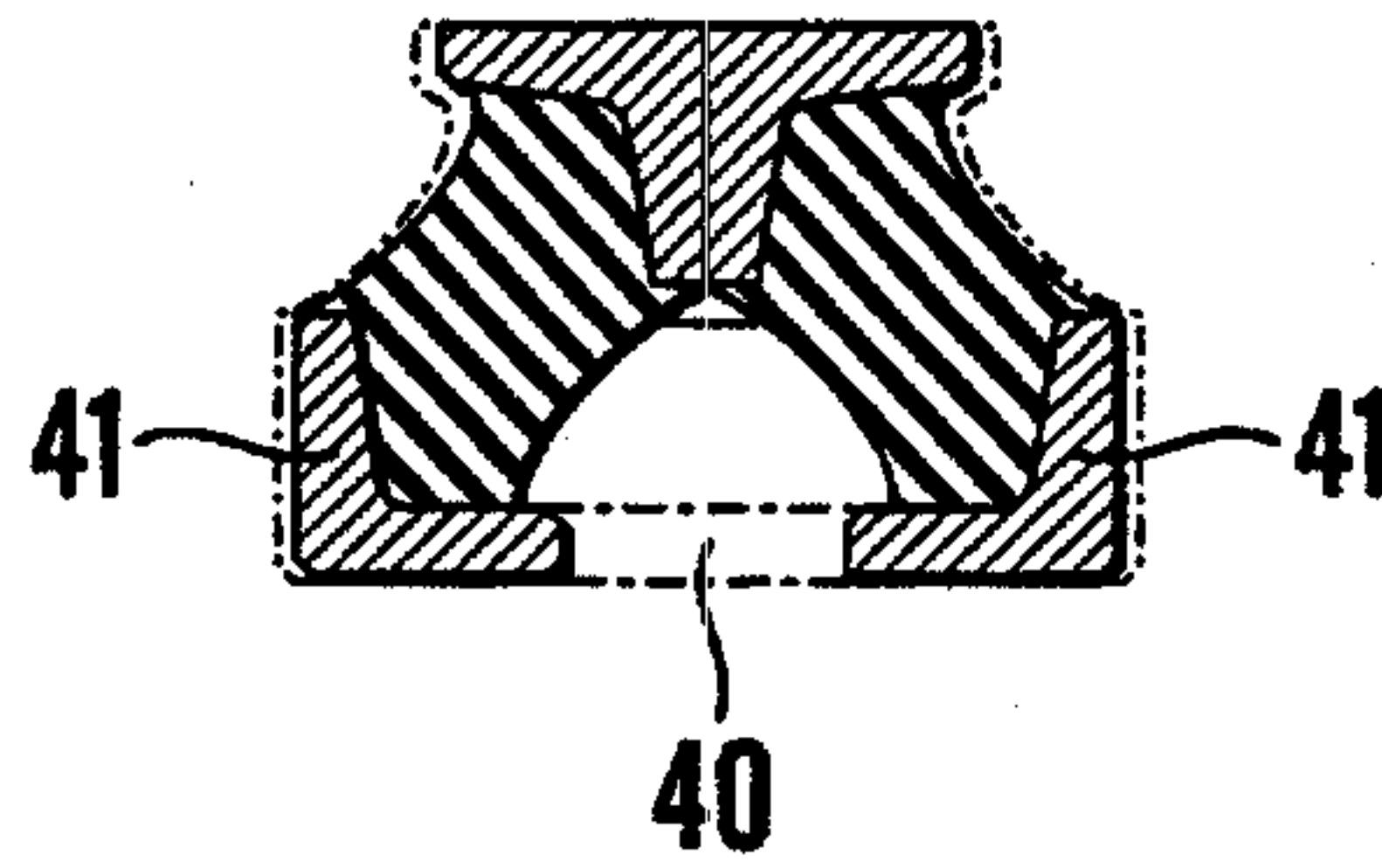

Fig. 12c

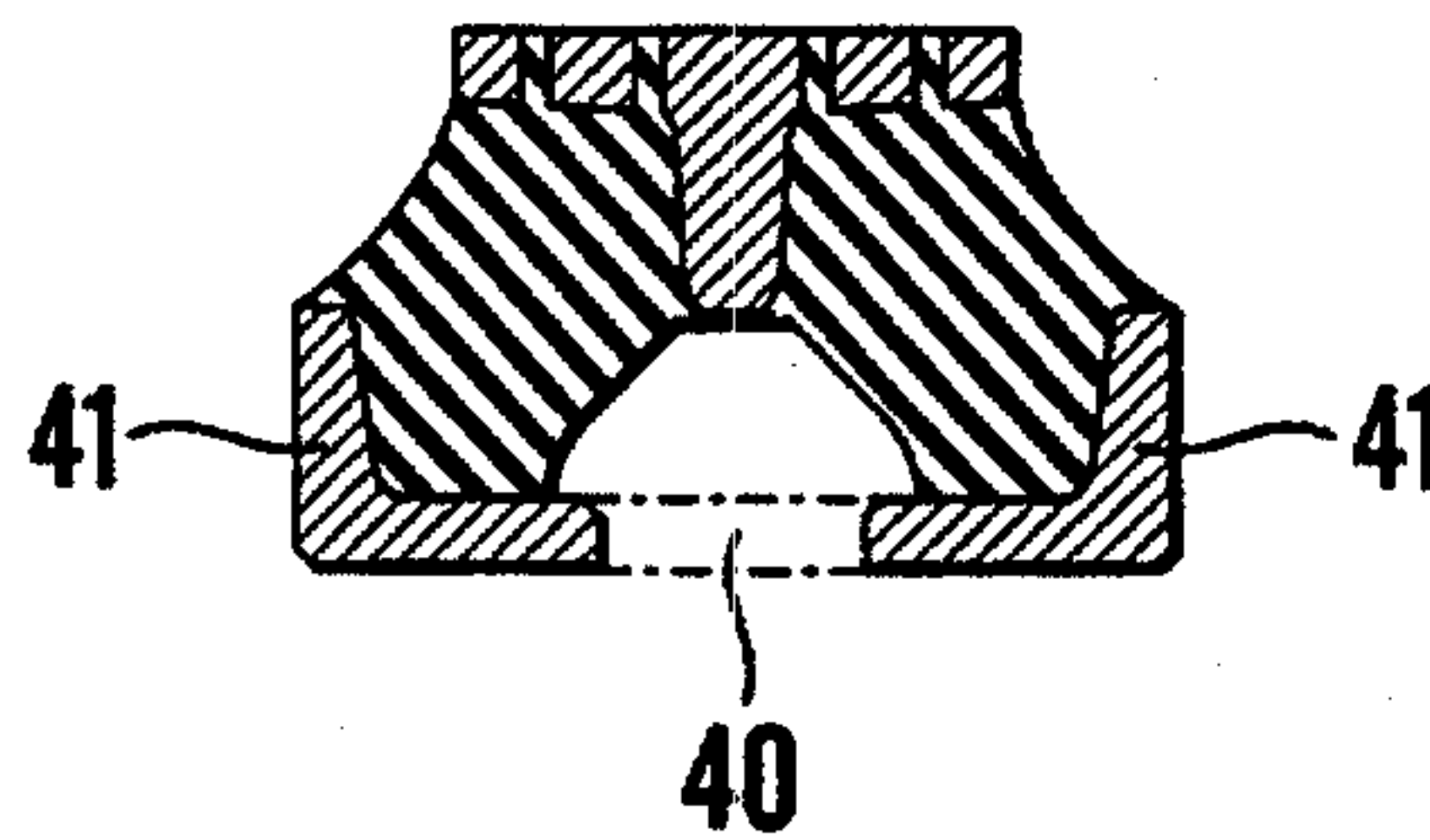

Fig. 12d

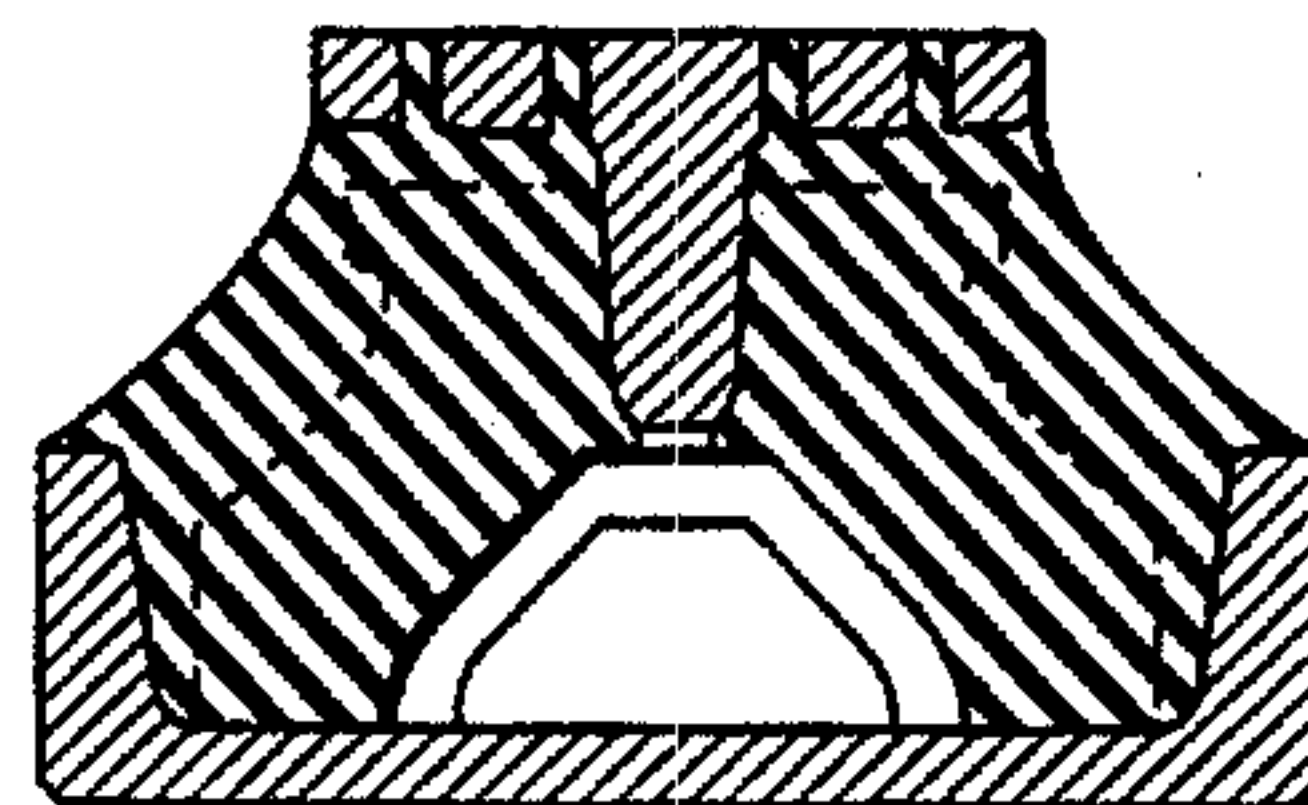
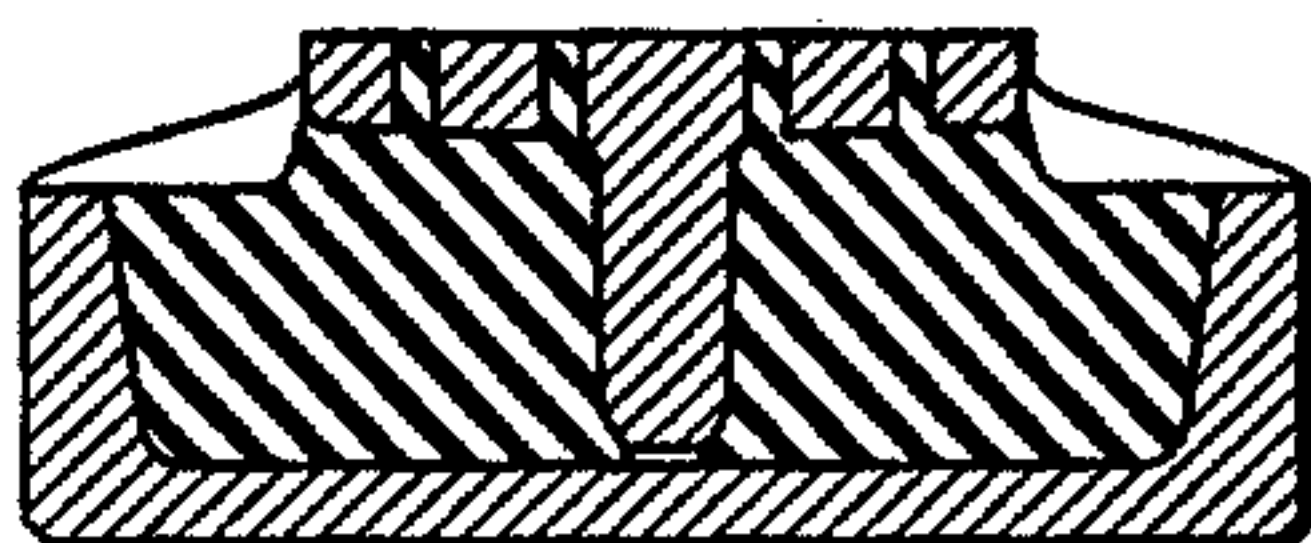

Fig. 12e

