

(19) World Intellectual Property Organization
International Bureau



(43) International Publication Date
26 January 2012 (26.01.2012)

PCT

(10) International Publication Number
WO 2012/012604 A1

- (51) International Patent Classification:
F04D 29/04 (2006.01)
- (21) International Application Number:
PCT/US2011/044796
- (22) International Filing Date:
21 July 2011 (21.07.2011)
- (25) Filing Language: English
- (26) Publication Language: English
- (30) Priority Data:
61/366,309 21 July 2010 (21.07.2010) US
- (71) Applicant (for all designated States except US): **ITT MANUFACTURING ENTERPRISES, INC.** [US/US]; 1105 North Market Street, Suite 1217, Wilmington, DE 19801 (US).
- (72) Inventors; and
- (75) Inventors/Applicants (for US only): **DAVIS, Mark, Alan** [US/US]; 9 Leland Drive, Seneca Falls, NY 13148 (US). **FALKIEWICZ, Timothy, Martin** [US/US]; 40 Lansing Street, Auburn, NY 13021 (US). **PLAYFORD, Mark, Alexander** [US/US]; 2229 Morris Drive, Seneca Falls, NY 13148 (US).
- (74) Agent: **BARBER, William, J.**; Ware, Fressola, Van Der Sluys & Adolphson LLP, 755 Main Street, P.O. Box 224, Monroe, CT 06468 (US).

(81) Designated States (unless otherwise indicated, for every kind of national protection available): AE, AG, AL, AM, AO, AT, AU, AZ, BA, BB, BG, BH, BR, BW, BY, BZ, CA, CH, CL, CN, CO, CR, CU, CZ, DE, DK, DM, DO, DZ, EC, EE, EG, ES, FI, GB, GD, GE, GH, GM, GT, HN, HR, HU, ID, IL, IN, IS, JP, KE, KG, KM, KN, KP, KR, KZ, LA, LC, LK, LR, LS, LT, LU, LY, MA, MD, ME, MG, MK, MN, MW, MX, MY, MZ, NA, NG, NI, NO, NZ, OM, PE, PG, PH, PL, PT, RO, RS, RU, SC, SD, SE, SG, SK, SL, SM, ST, SV, SY, TH, TJ, TM, TN, TR, TT, TZ, UA, UG, US, UZ, VC, VN, ZA, ZM, ZW.

(84) Designated States (unless otherwise indicated, for every kind of regional protection available): ARIPO (BW, GH, GM, KE, LR, LS, MW, MZ, NA, SD, SL, SZ, TZ, UG, ZM, ZW), Eurasian (AM, AZ, BY, KG, KZ, MD, RU, TJ, TM), European (AL, AT, BE, BG, CH, CY, CZ, DE, DK, EE, ES, FI, FR, GB, GR, HR, HU, IE, IS, IT, LT, LU, LV, MC, MK, MT, NL, NO, PL, PT, RO, RS, SE, SI, SK, SM, TR), OAPI (BF, BJ, CF, CG, CI, CM, GA, GN, GQ, GW, ML, MR, NE, SN, TD, TG).

Published:

- with international search report (Art. 21(3))
- before the expiration of the time limit for amending the claims and to be republished in the event of receipt of amendments (Rule 48.2(h))

(54) Title: PUMP DESIGNED FOR INSTALLATION CONVERSION

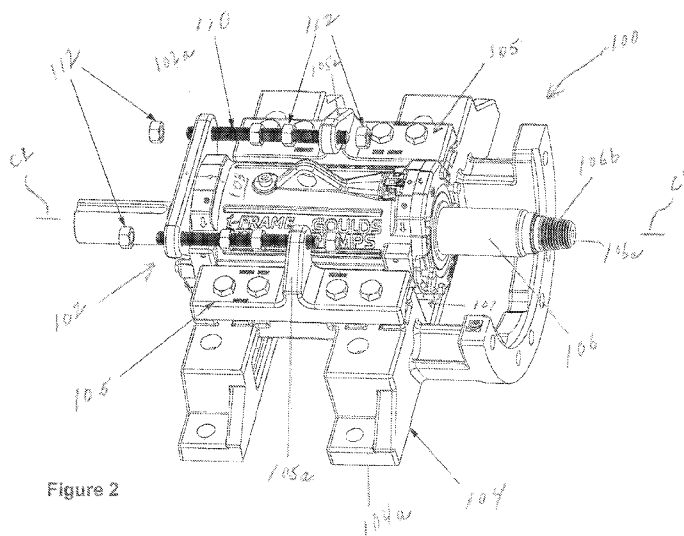

(57) Abstract: Apparatus is provided featuring a bearing cartridge in combination with a pedestal. The bearing cartridge may be configured to be coupled to a pumping assembly combination and having a predetermined centerline. The pedestal may be configured with an axial channel to receive and support the bearing cartridge and allow the bearing cartridge to slide therein. The bearing cartridge and the pedestal are configured to couple together substantially at or above the centerline of the bearing cartridge in order to reduce center height requirements of the apparatus, where the center height is defined as the distance between the centerline of the bearing cartridge and the bottom surface of the pedestal supporting the bearing cartridge. The apparatus takes the form of a pump or pumping assembly, arrangement or combination, including a slurry-type pump or a centrifugal pump.



WO 2012/012604 A1

PUMP DESIGNED FOR INSTALLATION CONVERSION

CROSS REFERENCE TO RELATED PATENT APPLICATION

This application claims benefit to patent application serial no. 61/366,309, filed
5 21 July 2010, which is hereby incorporated by reference in its entirety.

BACKGROUND OF THE INVENTION

1. Field of the Invention

The present invention relates to a pump or pumping assembly, arrangement
10 or combination; and more particularly relates to a pump or pumping assembly,
arrangement or combination designed for installation conversion, e.g., for a
centrifugal pump, a slurry-type pump, as well as other types or kinds of rotary
equipment such as fans or compressors.

15 2. Brief Description of Related Art

When pumps get old and/or worn out, they need to be replaced. However,
when an older pump is replaced with a newer pump, issues can arise in relation to
an installation conversion. For example, known pump designs have a wide variety of
center heights, bolt patterns, and drive configurations, many times making it difficult
20 to interchange the pump, e.g., without removing concrete foundations. This is
typically expensive and can lead to significant delays in the pump replacement
process.

By way of example, Figures 1a, 1b, 1c show prior art pump designs.

Figure 1a shows a known pedestal design generally indicated as 10 having an
25 adjusting bolt arrangement generally indicated by an arrow 12 arranged in a base 13
under a bearing cartridge generally indicated as 14 having a power transmitting shaft

17 arranged therein, the bolt arrangement 12 configured for adjusting the relationship between the bearing cartridge 14 and a pump shell 18 having an impeller (not shown) arranged therein.

5 Figure 1b shows another known pump design generally indicated as 20 also having its adjusting screw 22 arranged in a base 23 under a bearing cartridge generally indicated by arrow 24 having a power transmitting shaft 27 arranged therein, the adjusting screw 22 configured for adjusting, e.g., the clearance of an impeller 26 coupled to the shaft 27 arranged in a pump shell 28.

10 Figure 1c shows still another known design generally indicated as 30 also having its adjusting screw arrangement generally indicated by arrow 32 arranged in a base 33 underneath a bearing assembly generally indicated by arrow 34 having a power transmitting shaft 37 coupled to an impeller 36 arranged therein, the adjusting screw arrangement 32 configured for adjusting the relationship between the bearing cartridge 34, impeller 36 and a pump shell 38.

15 One problem with these known pump designs in Figures 1a, 1b and 1c is that each requires increasing the center height (CH) (see Figure 1a) to allow someone to gain access to the adjusting screw when the pump is assembled, where the center height (CH) is defined as the distance between the axis or centerline (CL) of the bearing cartridge and the bottom of the base supporting the bearing cartridge. The
20 increased center height (CH) of these known pumps can become a significant limiting factor during pump installation conversion, especially in cases where the pump being replaced has one center height and is situated on a concrete foundation that has a predetermined height of its own. These combined heights will affect the center height of the replacement pumps that can be used in the installation

conversion and determine whether the replacement of the pump can be made without removing concrete foundations.

In view of this, there is a long felt need in the industry for an improved pump design or technique that solves the problems related to installation conversion when
5 pumps need to be replaced.

SUMMARY OF THE INVENTION

To overcome the aforementioned problems, a new technique has been developed that takes the form of apparatus featuring a bearing cartridge in
10 combination with a pedestal. The bearing cartridge may be configured to be coupled to a pumping assembly combination and having a predetermined centerline. The pedestal may be configured with an axial channel to receive and support the bearing cartridge and allow the bearing cartridge to slide therein. The bearing cartridge and the pedestal are configured to couple together substantially at or above the
15 centerline of the bearing cartridge in order to reduce center height requirements of the apparatus, where the center height is defined as the distance between the centerline of the bearing cartridge and the bottom surface of the pedestal supporting the bearing cartridge. The apparatus takes the form of a pump or pumping assembly, arrangement or combination, including a slurry-type pump or a centrifugal
20 pump.

According to some embodiments, and provided by way of example, the apparatus may also include one or more of the following features:

1) The bearing cartridge and the pedestal are configured to couple together by an adjustable mounting assembly.

2) The adjustable mounting assembly may include, e.g., at least one mounting member coupled to the pedestal; at least one corresponding mounting member coupled to the bearing cartridge; and an arrangement of threaded bolts or rods and nuts configured to couple the at least one mounting member of the pedestal and at least one corresponding mounting member of the bearing cartridge so as to slide the bearing cartridge in relation to the pedestal when one or more of the nuts is turned.

3) The apparatus may also include a base adapter configured to be arranged between the pedestal and a pre-existing supporting foundation and to support the pedestal on the pre-existing supporting foundation.

One advantage of the new design or technique is that it offers users the ability to completely replace an existing pump without disturbing the original foundation or suction/discharge piping (depending on user preference). The user can then benefit from improvements in a bearing cartridge or assembly design as well as improvements in wet end design with very little installation effort.

An additional advantage is afforded to the manufacturer as a pump with a low center height and corresponding foundation cannot be replaced by competitors, requiring new foundations and dissuading customers from replacing the piece of equipment.

In effect, the new design or technique consists of a pump with a wet end and a powerframe (also called a bearing frame or power end). The powerframe has a center to base height very near the minimum achievable with current materials technology, significantly less than current offerings. This allows for cast, fabricated, or machined spacers to be put between the powerframe of the new pump and the existing foundation to allow the adjustment of the new pump's center height and position relative to drive elements (motor and gearbox shafts) and suction or

discharge piping. Different spacers can be provided to allow a single model of pump to be adapted to multiple models of competitor equipment.

This reduction in center height is achieved by a number of new, unique design features:

- 5 • Bearing cartridge lubricant sump designed to allow optimal lubrication oil volume while decreasing centerline height.
- Wet end (casing, impeller, and gland components) attached to bearing pedestal solely by members at or near centerline. Traditional designs connect wet end to bearing pedestal using at least one member below the centerline.
- 10 • Design of pedestal and bearing cartridge that moves sliding interface between bearing cartridge and pedestal substantially at or above centerline of bearing cartridge. This allows a greater mass of material to be incorporated in the pedestal to add strength and absorb vibration while still maintaining a low center height. There are many slurry pump manufacturers and almost all make conversion
- 15 kits for competitor pumps, but none are known to have specifically designed a complete pump for use in converting competitor installations. The typical approach is to produce a wet end conversion kit, which substitutes only the wetted wear parts of the original pump for a competitor's and leaves the existing bearing frame & support pedestal intact. This design or technique replaces the entire pump, giving the end
- 20 user the benefit of bearing frame and pedestal improvements as well as wetted wear part improvements. This design or technique specifically targets complete pump replacements, in accordance with the disclosure provided herein.

According to some embodiments of the present invention, the apparatus may comprise bearing cartridge means for coupling to a shaft of a motor and having a

25 predetermined centerline; pedestal means for receiving and supporting the bearing

cartridge and allowing the bearing cartridge to slide within an axial channel; and means for coupling together the bearing cartridge means and the pedestal means substantially at or above the centerline of the bearing cartridge in order to reduce center height requirements of the apparatus, consistent with that disclosed herein.

5

BRIEF DESCRIPTION OF THE DRAWING

The drawing includes the following Figures, not necessarily drawn to scale:

Figure 1a shows a side view of a pump that is known in the art.

Figure 1b shows a side cross-sectional view of another pump that is known in
10 the art.

Figure 1c shows a side cross-sectional view of still another pump that is known in the art.

Figure 2 shows a top perspective view of a powerframe having a shaft with tapered threads according to some embodiments of the present invention.

15 Figure 3 shows an exploded view of a pumping arrangement having an impeller with corresponding tapered impeller threads according to some embodiments of the present invention.

Figure 4 shows a cross-section view of a pump or pumping assembly, arrangement or combination according to some embodiments of the present
20 invention.

Figure 5 is a diagram of a pump or pumping assembly, arrangement or combination according to some embodiments of the present invention.

In the following description of the exemplary embodiment, reference is made to the accompanying drawings, which form a part hereof, and in which is shown by way of illustration of an embodiment in which the invention may be practiced. It is to be understood that other embodiments may be utilized, as structural and operational changes may be made without departing from the scope of the present invention.

DETAILED DESCRIPTION OF THE INVENTION

Figures 2 and 3

By way of example, the present invention is described in relation to the pump assembly, arrangement or combination shown in Figures 2-3, although the scope of the invention is intended to include apparatus, such as other types or kinds of rotary equipment, assemblies, arrangements, devices or combinations having a rotating shaft coupled directly to an impeller, that are either now known or later developed in the future. For example, Figures 2-3 show apparatus in the form of a part of a pump assembly, arrangement or combination, where Figure 2 shows apparatus or combination generally indicated as 100 having a power frame 102, a bearing cartridge 103, a pedestal 104 and a power transmission shaft 106; and where Figure 3 shows a pumping assembly combination generally indicated as 200 having outer casing sub-components 202a and 202b, a pump or volute liner 204, an impeller 206, front and rear liners and/or covers 208a, 208b and a gasket 210. The pedestal 104 is configured with an axial channel generally indicated by arrow 107 to receive and support the bearing cartridge 103 and allow the bearing cartridge 103 to slide therein. The power transmission shaft 106 has an end 106a with tapered threads 106b. The impeller 206 has a bore 206a having corresponding threads 206b. By way of example, when the bearing cartridge is coupled or assembled to the pumping

assembly combination 200, , the power transmission shaft 106 may be coupled directly to the impeller 206 so that the tapered threads 106b of the power transmission shaft 106 rotationally mate and frictionally engage the corresponding tapered threads 206b of the impeller 206, although the scope of the invention is intended to include other types or kind of couplings either now known or later developed in the future. Other parts of the apparatus or combination 100 (Figure 2) and the pumping assembly combination 200 are also mated together, which do not form part of the underlying invention and are not described in detail.

In Figure 2, the power frame 102 has an end cover 102a having bores and turns (unlabeled). The pedestal 104 also has hold down plates 105 having wings 105a with holes that penetrate to allow threaded bolts or rods 110 to pass through. A bearing cartridge 103 may be mounted in the pedestal 104 on wings (not shown) that mate with machined grooves or ways (not shown) in the pedestal 104. The apparatus or combination 100 also includes an adjustable mounting assembly configured with threaded bolts or rods 110 arranged in holes of the end cover 102a and the corresponding holes in the wings 105a. The adjustable mounting assembly also includes nuts 112 for adapting on the threaded bolts or rods 110, which may be loosened and tightened in a manner that would be appreciated by one skilled in the art without undue experimentation in order to move, slide or adjust the power frame 102 and bearing cartridge 103 in relation to the pedestal 104, and further in relation to the pumping assembly combination 200. The hold-down plates 105 are configured to clamp the bearing cartridge 103 in the pedestal 104 to prevent its movement after it has been appropriately adjusted, and are also configured with grooves machined therein (not shown). Appropriate pairs of nuts 112 are suitably

tightened on both sides of the end plate 102a and the wings 105a in order to secure the bearing cartridge 103 in relation to pedestal 104 and the pumping assembly combination 200.

The bearing cartridge 103 has a predetermined centerline that is indicated, by way of example, as reference label CL. For the purpose of describing some embodiments of the present invention, in Figure 2 the centerline is shown about or approximately in line with the axis of the power frame shaft 106, although the scope of the invention is not intended to be limited to how the centerline CL is predetermined. For example, embodiments of the invention are envisioned in which the centerline is predetermined to be above or below the axis of the power frame shaft 106 within the spirit of the present invention.

The pedestal 104 has a bottom surface 104a. According to some embodiments of the present invention, the bearing cartridge 103 and the pedestal 104 are configured to couple together above the centerline CL of the bearing cartridge 103 in order to reduce center height requirements of the apparatus 100, where the center height CH is defined as the distance between the centerline CL of the bearing cartridge 103 and the bottom surface 104a of the pedestal 104 supporting the bearing cartridge 103. By way of example, the centerheight CH is marked and shown in Figure 4.

According to the present invention, the bearing cartridge 103 and the pedestal 104 are configured to couple together substantially at or above the centerline CL of the bearing cartridge 103 in order to reduce center height requirements of the apparatus 100. According to the present invention, the phrase "substantially at" is intended to include embodiments or implementations where the bearing cartridge 103 and the pedestal 104 are coupled together at or near the centerline of the

bearing cartridge 103, and the term "above" is intended to include embodiments or implementations where the bearing cartridge 103 and the pedestal 104 are coupled together over or higher than the centerline CL of the bearing cartridge 103.

The other parts of the pumping assembly combination 200 shown in Figure 3, including the outer casing sub-components 202a and 202b, the pump or volute liner 204, the front and rear liners and/or covers 208a, 208b and the gasket 210 do not form part of the underlying invention, are known in the art, and are not described in detail herein. Embodiments are also envisioned in which a doubled casing design may be used, e.g., such that expensive hard metal parts are contained within an outer casing of ductile iron.

Moreover, the bearing cartridge 103 may also be configured to be coupled to a shaft or a motor (not shown). This coupling does not form part of the underlying invention, especially in relation to the features of the apparatus 100, and thus is not shown or described in detail. In view of this, the scope of the invention is not intended to be limited to the way the bearing cartridge 103 and motor are coupled together. For example, the bearing cartridge 103 may be coupled to the motor by various means or techniques within the scope and spirit of the present invention, including being directly coupled, being coupled through belt drives, as well as being coupled through some other intermediate equipment or apparatus either now known or later developed in the future.

Figure 4

Figure 4 shows apparatus 100' according to some embodiments of the present invention, which places the mounting arrangement, including adjusting threaded bolts or rods above the centerline CL of the bearing cartridge 103' to

reduce center height requirements. Similar parts in Figures 2-3 are numbered with similar reference numerals in Figure 4 with the addition of a single quote mark (" ' ").

In Figure 4, the apparatus 100' may also include a base adapter 150 configured to be arranged between the pedestal 104' and a pre-existing supporting foundation indicated with reference label 155 and also configured to support the pedestal 104' on the pre-existing supporting foundation 155. Base adapters are known in the art, and the scope of the present invention is not intended to be limited to any particular type or kind thereof, and may include base adapter configuration both now known and later developed in the future.

10

Figure 5

Figure 5 shows apparatus 100" according to some embodiments of the present invention. In Figure 5, the mounting arrangement is not shown. Similar parts in Figures 2-4 are numbered with similar reference numerals in Figure 5 with the addition of a double quote mark (' " '). The centerline CL" and center height CH" are indicated and determined consistent with that set forth above, which is an indication of the distance from the axis of the shaft 106" and the bottom surface 104a" of the pedestal 104". In this embodiment, the bearing cartridge 103" is configured with wings 103a and 103b extending laterally from an upper surface of the bearing cartridge as shown. Each wing 103a and 103b has a mounting member 103a1 and 103b1 having a respective hole configured therein for receiving a threaded bolt or rod (not shown in Figure 5) and for coupling to a corresponding mounting member 104d1 and 104d2 of the pedestal 104", consistent with that set

20

forth herein. This embodiment is shown as another example of an implementation of the present invention, and the scope of the invention is intended to include other implementations within the spirit of the present invention.

5

THE SCOPE OF THE INVENTION

It should be understood that, unless stated otherwise herein, any of the features, characteristics, alternatives or modifications described regarding a particular embodiment herein may also be applied, used, or incorporated with any other embodiment described herein. Also, the drawings herein are not drawn to
10 scale.

Although the invention has been described and illustrated with respect to exemplary embodiments thereof, the foregoing and various other additions and omissions may be made therein and thereto without departing from the spirit and scope of the present invention.

15

WHAT WE CLAIM IS:

1. Apparatus comprising:

a bearing cartridge configured to be coupled to a pumping assembly

combination and having a predetermined centerline; and

5 a pedestal configured with an axial channel to receive and support the bearing cartridge and allow the bearing cartridge to slide therein; and

the bearing cartridge and the pedestal configured to couple together substantially at or above the centerline of the bearing cartridge in order to reduce center height requirements of the apparatus.

10

2. Apparatus according to claim 1, wherein the center height is defined as the distance between the centerline of the bearing cartridge and the bottom surface of the pedestal supporting the bearing cartridge

15

3. Apparatus according to claim 1, wherein the bearing cartridge and the pedestal are configured to couple together by an adjustable mounting assembly.

4. Apparatus according to claim 3, wherein the adjustable mounting assembly comprises

at least one mounting member coupled to the pedestal;

at least one corresponding mounting member coupled to the bearing

5 cartridge; and

an arrangement of threaded bolts or rods and nuts configured to couple the at least one mounting member of the pedestal and at least one corresponding mounting member of the bearing cartridge so as to slide the bearing cartridge in relation to the pedestal when one or more of the nuts is turned.

10

5. Apparatus according to claim 4, wherein the at least one mounting member includes hold down plates having wings with holes that penetrate to allow the threaded bolts or rods to pass through.

15

6. Apparatus according to claim 5, wherein the hold-down plates are configured to clamp the bearing cartridge in the pedestal to prevent its movement after it has been adjusted.

20

7. Apparatus according to claim 1, wherein the apparatus takes the form of a pump or pumping assembly, arrangement or combination, including a slurry-type pump or a centrifugal pump.

8. Apparatus according to claim 1, wherein the apparatus comprises a base adapter configured to be arranged between the pedestal and a pre-existing supporting foundation and to support the pedestal on the pre-existing supporting foundation.

5

9. Apparatus according to claim 3, wherein the adjustable mounting assembly also includes nuts for adapting on threaded bolts or rods, which are configured to be loosened and tightened in order to move, slide or adjust a power frame and the bearing cartridge in relation to the pedestal, and further in relation to the pumping assembly combination.

10

10. Apparatus comprising:

bearing cartridge means for coupling to a pumping assembly combination and having a predetermined centerline;

15

pedestal means for receiving and supporting the bearing cartridge and allowing the bearing cartridge to slide within an axial channel; and

means for coupling together the bearing cartridge means and the pedestal means substantially at or above the centerline of the bearing cartridge in order to reduce center height requirements of the apparatus.

20

11. Apparatus according to claim 10, wherein the center height is defined as the distance between the centerline of the bearing cartridge means and the bottom surface of the pedestal means supporting the bearing cartridge

12. Apparatus according to claim 10, wherein the means for coupling together the bearing cartridge means and the pedestal means comprises an adjustable mounting assembly means.

5 13. Apparatus according to claim 12, wherein the adjustable mounting assembly means comprises

 at least one mounting member coupled to the pedestal means;

 at least one corresponding mounting member coupled to the bearing cartridge means; and

10 an arrangement of threaded bolts or rods and nuts configured to couple the at least one mounting member of the pedestal means and at least one corresponding mounting member of the bearing cartridge means so as to slide the bearing cartridge means in relation to the pedestal when one or more of the nuts is turned.

15 14. Apparatus according to claim 13, wherein the at least one mounting member includes hold down plates having wings with holes that penetrate to allow the threaded bolts or rods to pass through.

20 15. Apparatus according to claim 14, wherein the hold-down plates are configured to clamp the bearing cartridge in the pedestal to prevent its movement after it has been adjusted.

25 16. Apparatus according to claim 10, wherein the apparatus takes the form of a pump or pumping assembly, arrangement or combination, including a slurry-type pump or a centrifugal pump.

17. Apparatus according to claim 10, wherein the apparatus comprises a base adapter means for arranging between the pedestal means and a pre-existing supporting foundation and for supporting the pedestal means on the pre-existing supporting foundation.

5

18. Apparatus according to claim 12, wherein the adjustable mounting assembly also includes nuts for adapting on threaded bolts or rods, which are configured to be loosened and tightened in order to move, slide or adjust a power frame and the bearing cartridge in relation to the pedestal, and further in relation to

10 the pumping assembly combination.

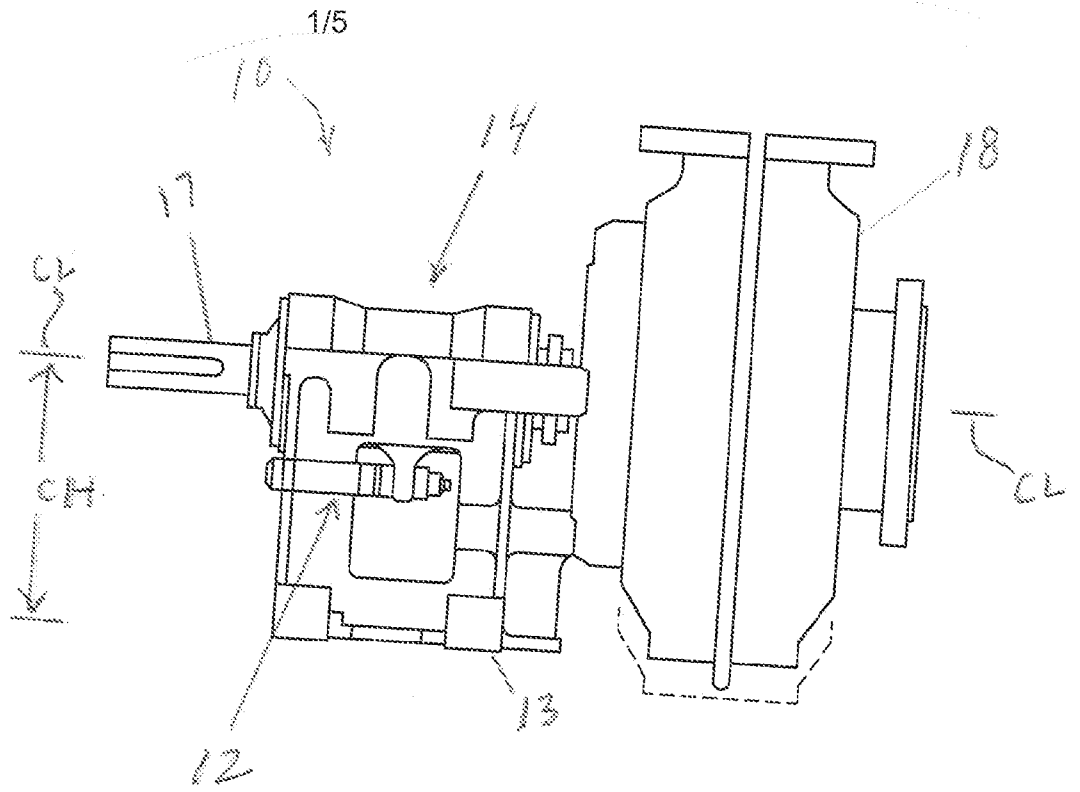

FIG. 1a

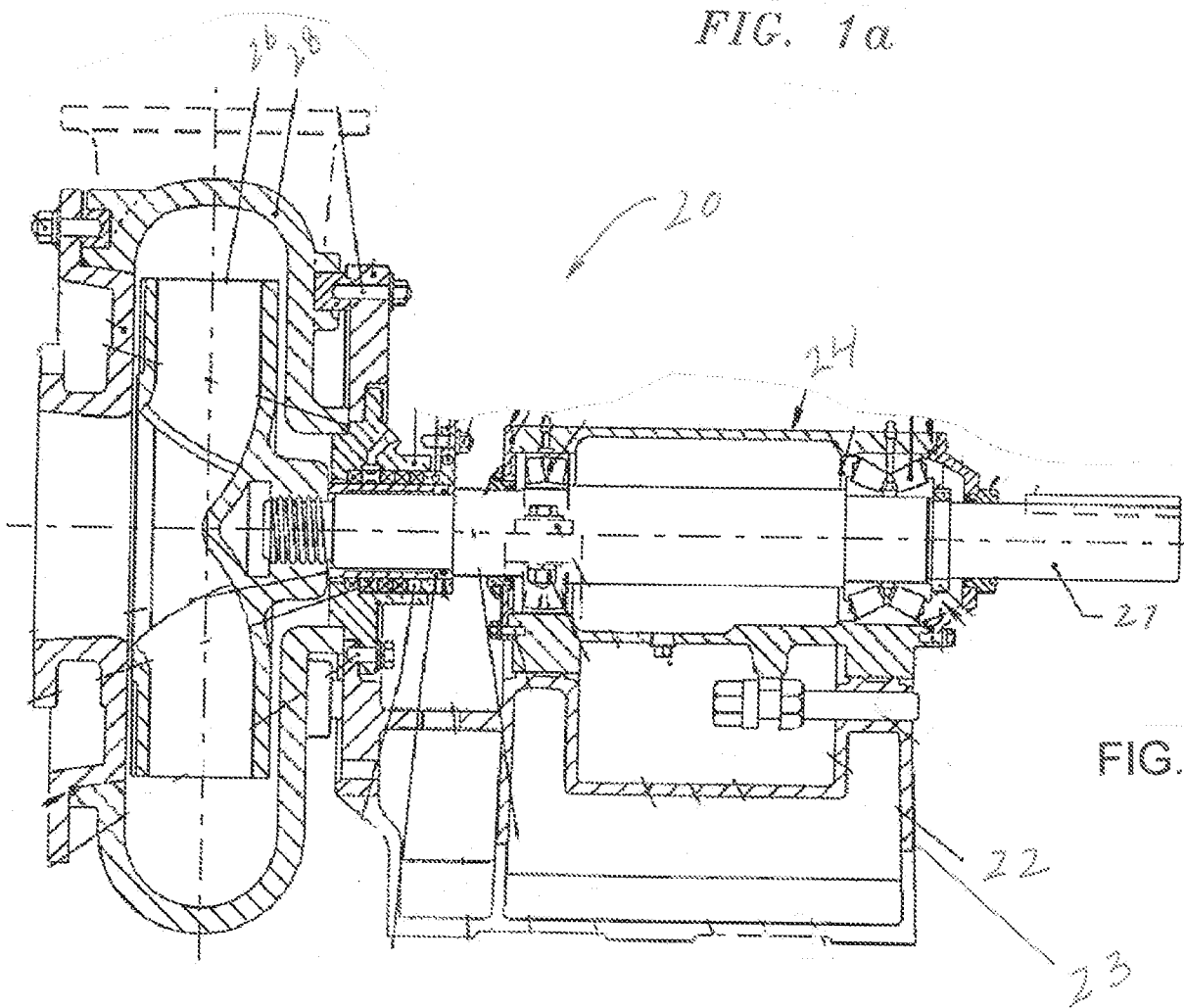

FIG. 1b

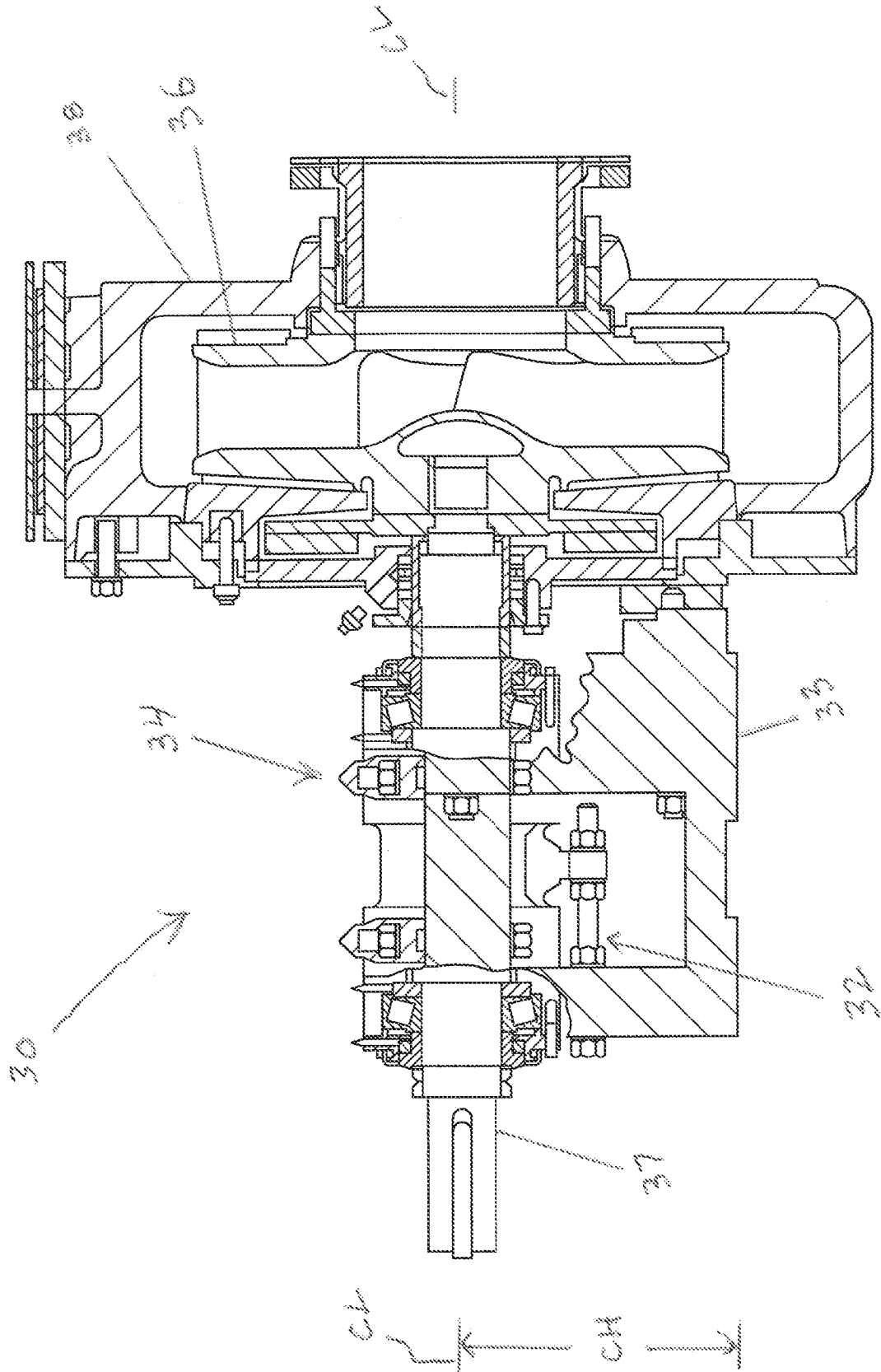

FIG. 1c

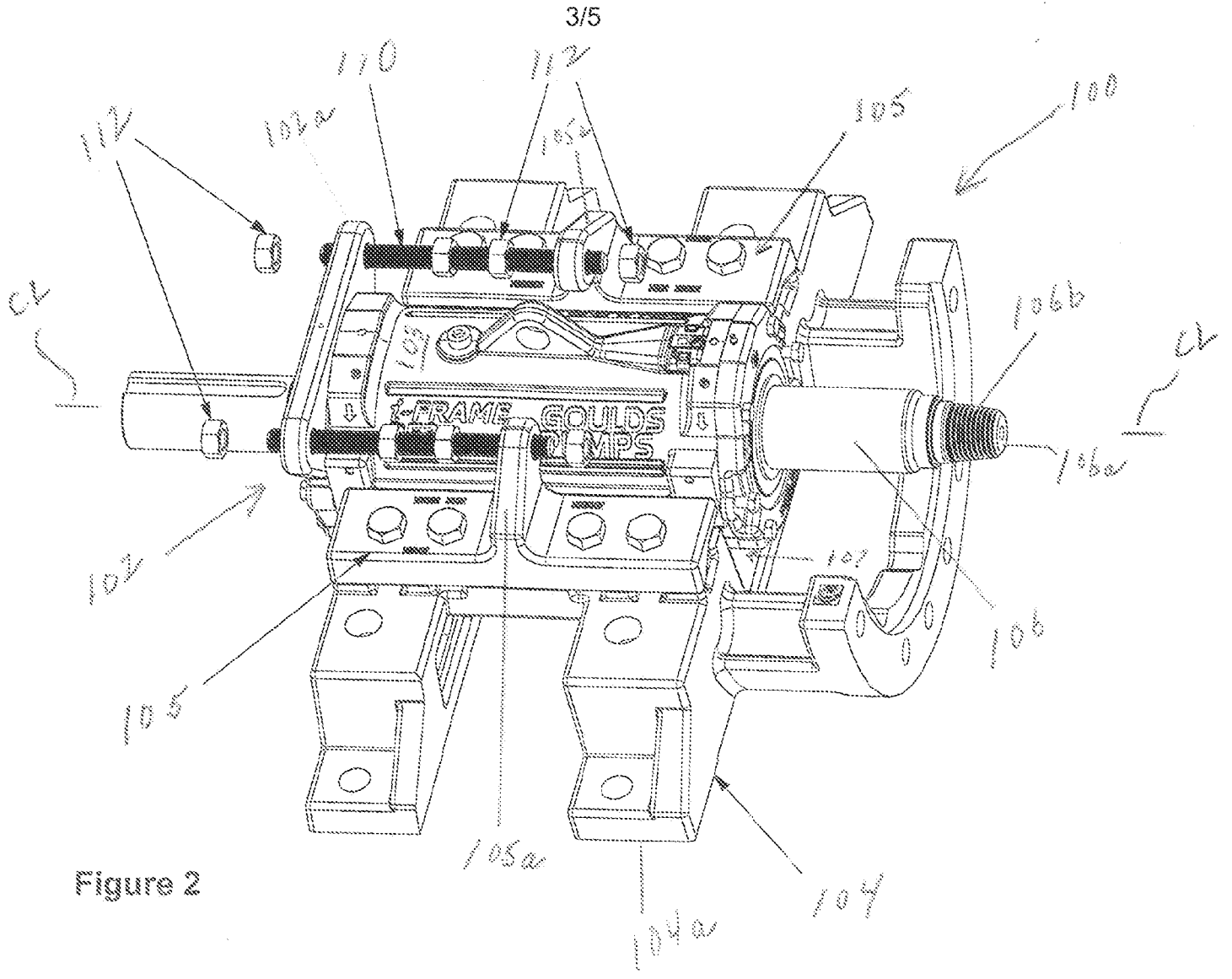

Figure 2

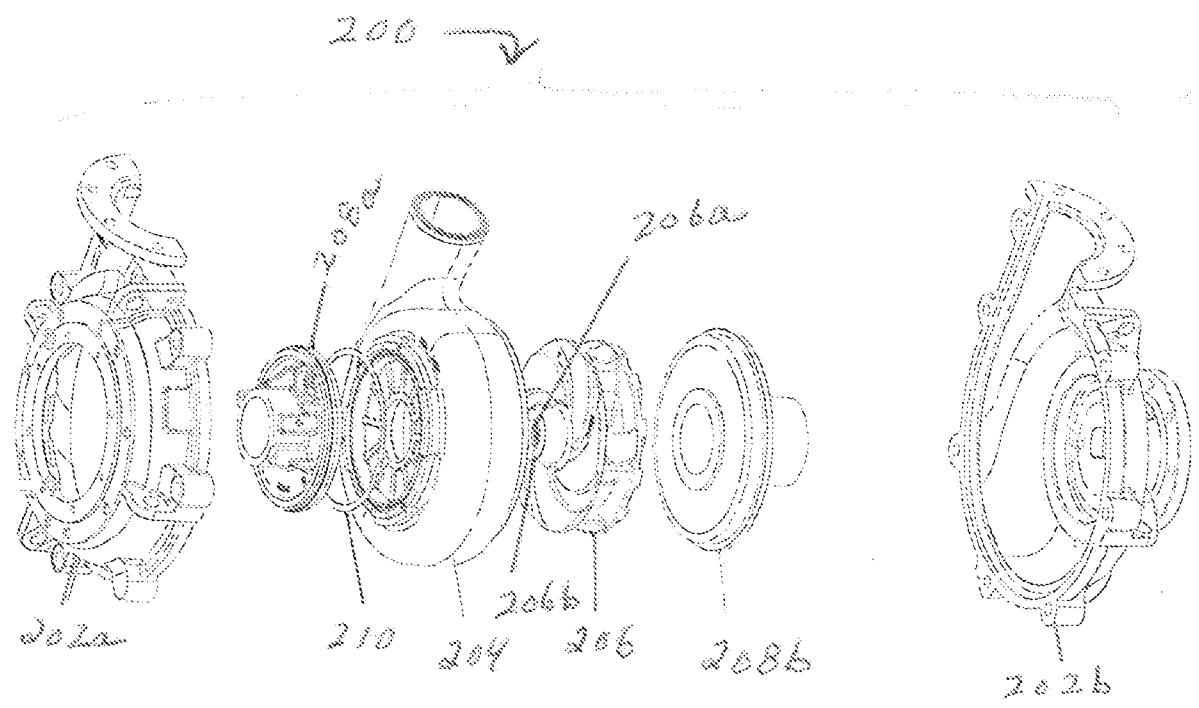

Figure 3

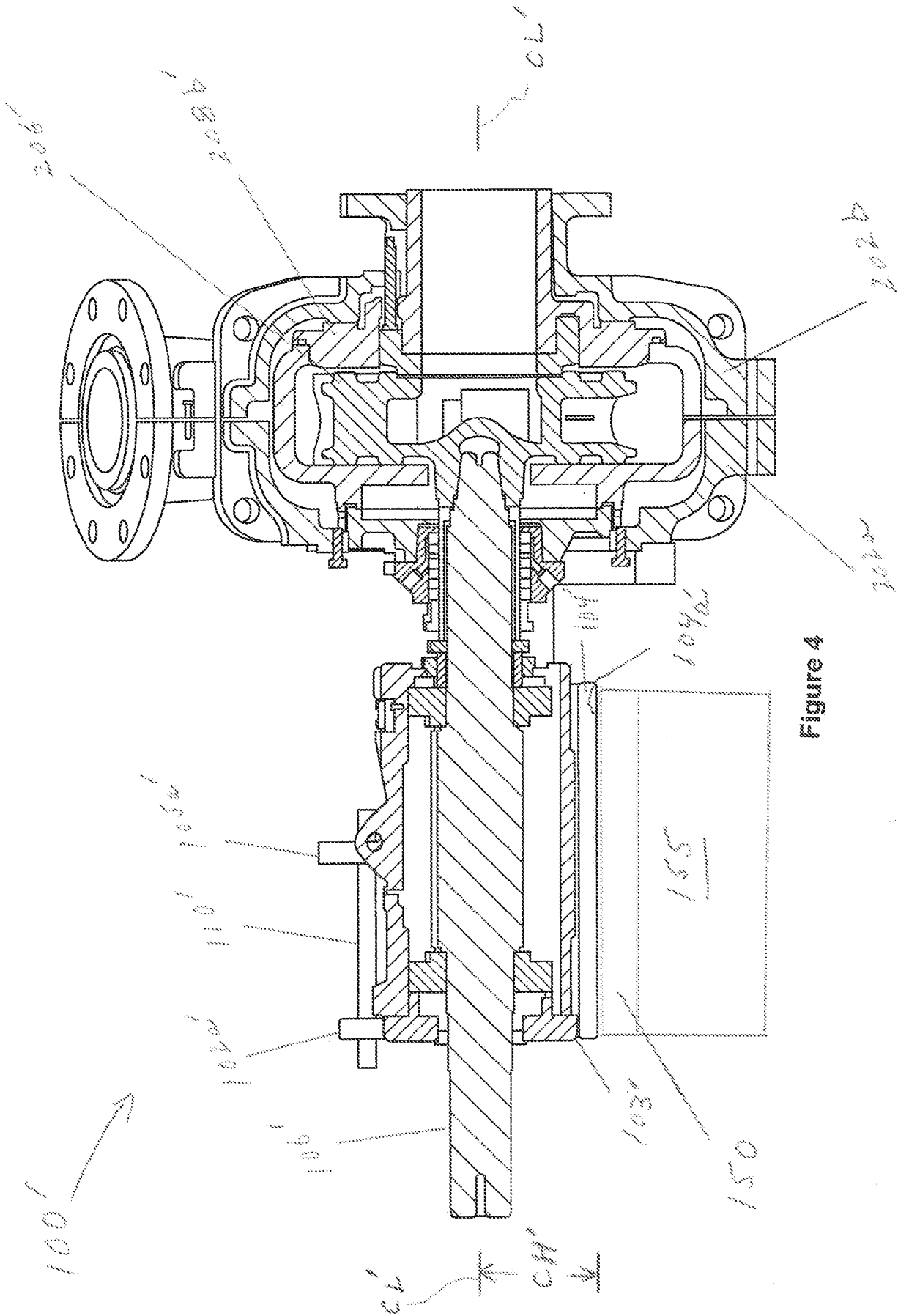

Figure 4

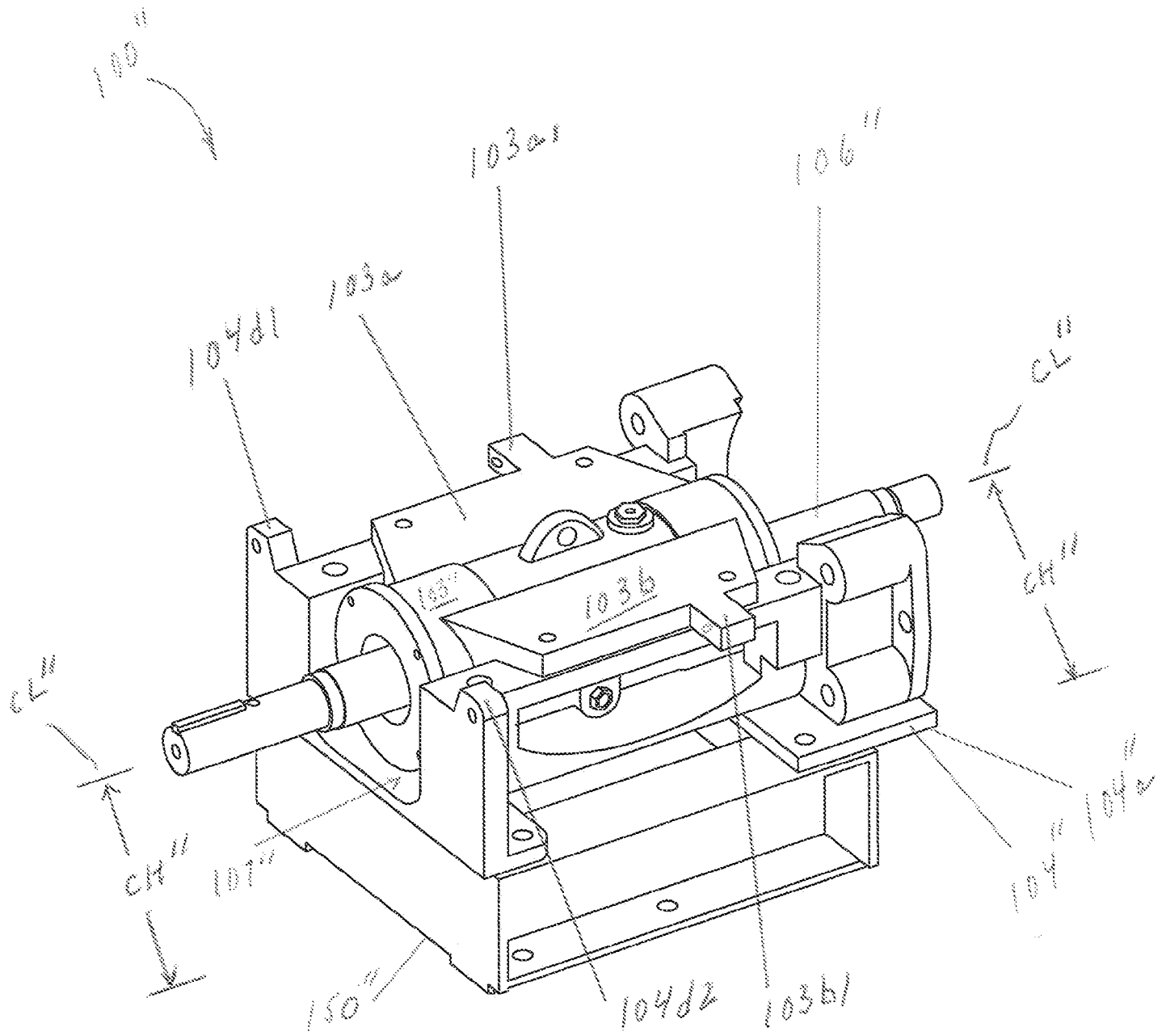

Figure 5

INTERNATIONAL SEARCH REPORT

International application No.

PCT/US2011/044796

A. CLASSIFICATION OF SUBJECT MATTER

IPC(8) - F04D 29/04 (2011.01)

USPC - 417/359

According to International Patent Classification (IPC) or to both national classification and IPC

B. FIELDS SEARCHED

Minimum documentation searched (classification system followed by classification symbols)

IPC(8) - F04D 1/00, 17/08, 29/04, 29/042, 29/60, 29/62 (2011.01)

USPC - 415/128, 131, 170.1, 174.1, 196, 229; 417/359, 360, 365, 900

Documentation searched other than minimum documentation to the extent that such documents are included in the fields searched

Electronic data base consulted during the international search (name of data base and, where practicable, search terms used)

USPTO EAST System (US-PGPUB; USPAT; USOCR; FPRS; EPO; JPO; DERWENT), PatBase

C. DOCUMENTS CONSIDERED TO BE RELEVANT

Category*	Citation of document, with indication, where appropriate, of the relevant passages	Relevant to claim No.
X	US 4,521,151 A (FRATER et al) 04 June 1985 (04.06.1985) entire document	1-5, 7, 8, 10-14, 16-17
A	US 2006/0051198 A1 (TORRES-REYES) 09 March 2006 (09.03.2006) entire document	1-18
A	US 5,344,291 A (ANTKOWIAK) 06 September 1994 (06.09.1994) entire document	1-18
A	US 7,074,017 B2 (CORAY et al) 11 July 2006 (11.07.2006) entire document	1-18

Further documents are listed in the continuation of Box C.

* Special categories of cited documents:

"A" document defining the general state of the art which is not considered to be of particular relevance

"E" earlier application or patent but published on or after the international filing date

"L" document which may throw doubts on priority claim(s) or which is cited to establish the publication date of another citation or other special reason (as specified)

"O" document referring to an oral disclosure, use, exhibition or other means

"P" document published prior to the international filing date but later than the priority date claimed

"T" later document published after the international filing date or priority date and not in conflict with the application but cited to understand the principle or theory underlying the invention

"X" document of particular relevance; the claimed invention cannot be considered novel or cannot be considered to involve an inventive step when the document is taken alone

"Y" document of particular relevance; the claimed invention cannot be considered to involve an inventive step when the document is combined with one or more other such documents, such combination being obvious to a person skilled in the art

"&" document member of the same patent family

Date of the actual completion of the international search

15 December 2011

Date of mailing of the international search report

28 DEC 2011

Name and mailing address of the ISA/US

Mail Stop PCT, Attn: ISA/US, Commissioner for Patents

P.O. Box 1450, Alexandria, Virginia 22313-1450

Facsimile No. 571-273-3201

Authorized officer:

Blaine R. Copenheaver

PCT Helpdesk: 571-272-4300

PCT OSP: 571-272-7774