

(19) World Intellectual Property Organization
International Bureau



(43) International Publication Date
8 April 2004 (08.04.2004)

PCT

(10) International Publication Number
WO 2004/028712 A1

(51) International Patent Classification⁷: B08B 7/00, G21F 9/00

Tristan, Goronwy [GB/GB]; British Nuclear Fuels plc, Research & Technology, Rutherford House, Risley, Warrington WA3 6AS (GB).

(21) International Application Number: PCT/GB2003/004103

(74) Agent: BARKER, Rosemary, Anne; Harrison Goddard Foote, Orlando House, 11c Compstall Road, Marple Bridge, Stockport SK6 5HH (GB).

(22) International Filing Date: 26 September 2003 (26.09.2003)

(81) Designated States (national): AE, AG, AL, AM, AT, AU, AZ, BA, BB, BG, BR, BY, BZ, CA, CH, CN, CO, CR, CU, CZ, DE, DK, DM, DZ, EC, EE, EG, ES, FI, GB, GD, GE, GH, GM, HR, HU, ID, IL, IN, IS, JP, KE, KG, KP, KR, KZ, LC, LK, LR, LS, LT, LU, LV, MA, MD, MG, MK, MN, MW, MX, MZ, NI, NO, NZ, OM, PG, PH, PL, PT, RO, RU, SC, SD, SE, SG, SK, SL, SY, TJ, TM, TN, TR, TT, TZ, UA, UG, US, UZ, VC, VN, YU, ZA, ZM, ZW.

(25) Filing Language: English

(26) Publication Language: English

(30) Priority Data: 0222341.0 26 September 2002 (26.09.2002) GB

(84) Designated States (regional): ARIPO patent (GH, GM, KE, LS, MW, MZ, SD, SL, SZ, TZ, UG, ZM, ZW), Eurasian patent (AM, AZ, BY, KG, KZ, MD, RU, TJ, TM), European patent (AT, BE, BG, CH, CY, CZ, DE, DK, EE, ES, FI, FR, GB, GR, HU, IE, IT, LU, MC, NL, PT, RO, SE, SI, SK, TR), OAPI patent (BF, BJ, CF, CG, CI, CM, GA, GN, GQ, GW, ML, MR, NE, SN, TD, TG).

(71) Applicant (for all designated States except US): BNFL (IP) LIMITED [GB/GB]; Risley, Warrington, Cheshire WA3 6AS (GB).

(72) Inventors; and

(75) Inventors/Applicants (for US only): BROWN, Stephen, Christopher, Neil [GB/GB]; British Nuclear Fuels plc, Research & Technology, Rutherford House, Risley, Warrington WA3 6AS (GB). SPENCER, Julian, Timothy [GB/GB]; British Nuclear Fuels plc, Research & Technology, Rutherford House, Risley, Warrington WA3 6AS (GB). BENJAMIN, Andrew, William [GB/GB]; British Nuclear Fuels plc, Research & Technology, Rutherford House, Risley, Warrington WA3 6AS (GB). THOMAS,

Declaration under Rule 4.17:

— of inventorship (Rule 4.17(iv)) for US only

Published:

— with international search report

[Continued on next page]

(54) Title: SURFACE TREATMENT OF CONCRETE

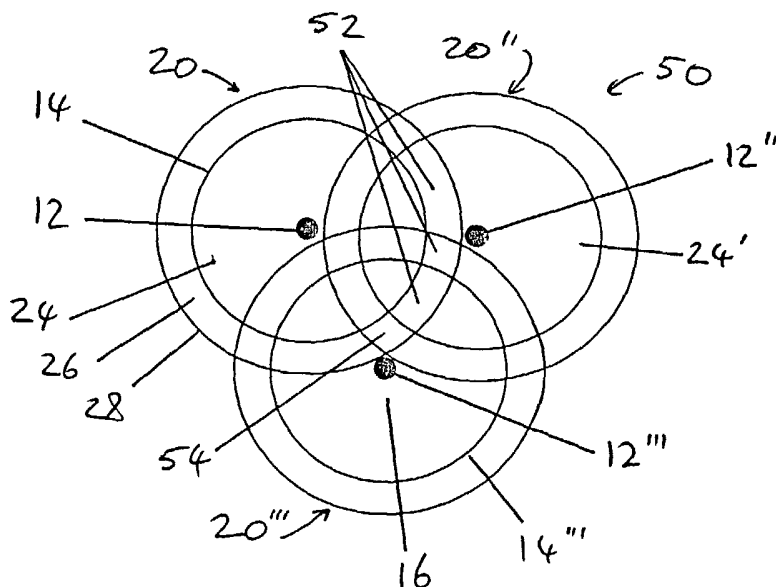

(57) Abstract: A method of treating a surface for the removal of a surface portion is described comprising the steps of: irradiating the surface with laser light characterised in that the irradiation is effected by covering said surface in a sequential manner with a plurality of discrete spots of laser light. The spots of laser light overlap and may be arranged in a geometric arrangement defined by the locations of the centres of the spots of laser light. The spots of laser light may be applied sequentially.

WO 2004/028712 A1



-
- *before the expiration of the time limit for amending the claims and to be republished in the event of receipt of amendments* *For two-letter codes and other abbreviations, refer to the "Guidance Notes on Codes and Abbreviations" appearing at the beginning of each regular issue of the PCT Gazette.*

Surface treatment of Concrete

5 Field of the invention

The present invention concerns surface removal from inorganic non-metallic structures, in particular concrete structures, primarily though not exclusively for the purpose of removing radioactive contamination contained
10 in surface layers.

Discussion of the Prior Art

15 In the nuclear industry surfaces of concrete structures may become contaminated with radionuclides. Common contaminants include uranium oxide, plutonium oxide, strontium-90, caesium-137 and cobalt-60. Typically this contamination is only present in a surface layer of
20 concrete. Such layers may be around 1 to 4mm or more in thickness. By removal of such a surface layer the degree of contamination of a surface and of the structure as a whole may be greatly reduced. However, simple mechanical methods may be unsuitable for use where a potential for
25 contamination makes it desirable for an operator to be remote from a surface to be operated upon.

Various techniques are known for the surface removal of concrete, stone and similar surfaces. One such method is
30 the heat treatment of a surface such as to degrade that surface and release a surface layer.

JP 3002595 describes the removal of a concrete surface layer by crushing due to the heat generated by the use of microwaves to irradiate a contaminated surface layer.

5 GB 2316528 describes a process for decontaminating a surface using a pulsed laser beam. Pulsed laser beams emit very high energy in very short pulses. The document describes pulses of 28ns duration, and a maximum
10 repetition rate of 250Hz (i.e. a pulse every 4ms), hence the time between pulses is approximately 140,000 times that of the duration of each pulse. Such high energy pulses often have peak power densities per pulse which are of the order of several tens of MW/cm², but which only last for the duration of the pulse. Such high peak
15 power densities give rise to ablative processes, such as vaporisation, sublimation or plasma formation, to effect removal of a very thin surface layer. Pulsed laser processes are characteristic in that the time interval between the very high energy, short pulses is several
20 orders of magnitude longer than the duration of each pulse. This gives a very high instantaneous energy intensity during the short duration of each pulse, but a lower power density when the output is averaged continuously over time.

25

EP-A-0653762 describes a method, termed scabbling, of modifying concrete by ejecting solid surface fragments, chips or flakes of material of significant size (e.g. several grams) and volume, thus causing surface removal.
30 In the method described a laser is used which is scanned across the surface in a raster scan. In such a method energy from the laser light heats the surface and causes surface fragments to break away or be ejected, often

violently, due to the generation of either steam or thermal stresses below the surface. This latter phenomenon of ejecting solid surface fragments, chips or flakes of material by use of a laser is known in the art
5 as laser scabbling.

However, it has been found that some surfaces, including some types of concrete having aggregate therein, whilst able to be successfully laser scabbled on a first scan of
10 the laser beam over the surface, may fail to scabble, or do so only with reduced efficiency, on areas which are either within or adjacent to a first scanned track when subjected to laser irradiation on either a subsequent re-treatment of the same area or on an adjacent scanned
15 track.

Summary of the invention

According to the present invention there is provided a
20 method of treating a surface for the removal of a surface portion comprising the step of irradiating the surface with laser light, characterised in that the irradiation is effected by covering said surface in a plurality of discrete spots of laser light each having an average
25 power density over the area of the spot of up to 200 W/cm².

The locations at which the laser is applied in the aforesaid, optionally sequential, manner may be defined
30 by the centres of the spots of laser light. The spots of laser light may overlap. The geometry of each spot of laser light at the point of application on the surface may be circular, ovoid, ellipsoidal, rectangular or

square dependent on the shape of the emitted laser beam and any modification of it by intervening optical elements.

5 A laser used for laser scabbling has a substantially continuous, rather than pulsed, output, although the laser may optionally be switched off during the periods of movement of the laser deployment system between the spot locations.

10

The spots of laser light are typically several tens of millimetres in diameter at the point of application on the element of the said surface and each spot is held stationary over the element of the surface being treated
15 for a period of seconds to tens of seconds before the laser is moved to the next application point.

The spots of laser light may be applied sequentially.

20 The method of the invention, of laser scabbling using spots of laser light, significantly reduces the creation of areas treated by the laser light which subsequently resist further laser scabbling treatments, when compared to other known methods of applying laser light of
25 substantially continuous power. In addition the method results in a flatter scabbled surface than with other known methods of laser scabbling.

The method of the invention, of laser scabbling using
30 spots of laser light, requires an average power density on the surface at the point of application of a spot, i.e. per spot, of laser light of above $30\text{W}/\text{cm}^2$ or thereabouts and below around $200\text{W}/\text{cm}^2$ or thereabouts.

Above an average power density of around $200\text{W}/\text{cm}^2$ the concrete may scabble for a short time, but this will usually result in melting of the concrete matrix which hinders further scabbling. Below an average power density of around $30\text{W}/\text{cm}^2$ the threshold energy intensity, which gives a heating rate sufficient to cause scabbling is unlikely to be reached.

A preferred average power density range for laser scabbling according to the invention is $50\text{W}/\text{cm}^2$ to $150\text{W}/\text{cm}^2$. An average power density per spot of laser light found to produce optimum scabbling results is of the order of $100\text{W}/\text{cm}^2$. The precise optimum average power density used will depend upon the characteristics of the surface to be scabbled such as concrete type, reflectivity etc.

The term average power density refers to power as averaged over the area of a spot of laser light. This is in contrast with a power density as averaged over time, which is not meant.

The scabbling of a concrete surface by a laser of substantially continuous power may be compared to the treatment of a surface by the pulsed laser typically used in ablative processes, and the resulting effects are significantly different. When scabbling by applying the continuous laser to the element of surface being treated for a duration of seconds or tens of seconds, the heat has sufficient time, and therefore the opportunity, to diffuse below the surface and build up the stresses and/or steam in an appreciable volume of material, resulting in the ejection of solid fragments, chips or

flakes of material of significant size. However, when using a pulsed ablative system, because of the short duration of the laser pulses (nanoseconds to milliseconds) in relation both to the interval between the pulses and to the time taken for heat to diffuse below the surface of the concrete, the energy input from the short pulses is of insufficient duration to heat the concrete beneath a very thin surface layer. Thus neither mechanical stresses nor steam can build up within a significant volume of material below the surface layer, and scabbling by ejection of solid fragments, chips or flakes of the material cannot therefore occur.

The energy delivered to a surface per spot of incident light in laser scabbling, which uses a laser of substantially constant intensity, lies between approximately 200 and 1350 J/cm², compared to around 0.7J/cm² for an ablative system, with a pulsed laser. The time over which a spot of laser light energy is delivered in laser scabbling is in the order of 1 to 30 seconds for the present invention. The equivalent time for ablative systems using a pulsed laser is typically in the order of 20ns.

The power density of a typical spot of laser light required for scabbling in the mode of the present invention, which is tens or hundreds of W/cm², is many orders of magnitude lower than that required for ablative processes such as are typical for pulsed laser treatment which is in the order of several tens of MW/cm²

The use of pulsed laser ablative processes would often be considered disadvantageous for the removal of radioactive

contaminants, as either the creation of plasmas or the vapourisation or sublimation of contaminants would lead to further airborne spread of contamination. Scabbling avoids these problems because relatively large (mm to cm) and solid surface fragments, chips or flakes are forcibly ejected from a surface being scabbled and can be readily collected using conventional solids collection methods, such as air extraction and filters.

However, problems have been found in the prior art with surface removal by laser scabbling which are associated with a non-uniform power distribution, for example, quasi-Gaussian, across a laser beam spot, and in particular with the presence of lower power density regions of an incident beam of laser light on the surface to be treated. The part of a beam of laser light incident upon a surface that is above a critical, or threshold, power density able to effect scabbling causes scabbling of the surface to occur. Any part of an incident laser beam, usually a peripheral part, which is below that threshold power density level, i.e. a part not subjecting a surface portion on which it is incident to a power density above a critical value, does not give rise to surface removal by scabbling, but the element of the surface treated by it is nevertheless heated. Such heating without scabbling may cause a number of processes to occur in the material, such as relaxation, dehydration and chemical change. These processes can result in the heat-affected surface no longer being amenable to subsequent surface removal by laser scabbling, even when that subsequent treatment is above the threshold power density to achieve scabbling. That is at least when laser light is used in a manner whereby surface removal would

otherwise be effected by scabbling, i.e. the ejection of surface chips, rather than by ablation.

Furthermore a non-uniform power distribution across a laser beam incident upon a surface may result in differential surface removal by scabbling between surface portions where a highest and a lower laser power density, both of which are above the threshold power density, are incident. For this reason, when linearly scanning or tracking a laser beam at a constant speed across a surface in order to scabble it, a furrow, or channel with sloping sides may be formed in a surface by a scanned laser beam impinging perpendicular to a surface. A subsequent scabbling attempt adjacent to this track by a similar perpendicular beam may result in laser light impinging upon that sloping surface portion resulting in a lower incident power density on the sloping surface area. The sloping sides may therefore cause an otherwise sufficient power density to either become insufficient; i.e. to fall below the threshold power density, or to scabble less surface material because of reduced power density and therefore reduced scabbling efficiency. As a result a whole surface when scabbled using laser light may be uneven.

25

In addition, laser scabbling processes may cause explosive detachment of surface fragments of a material being treated, as in the scabbling of concrete. To overcome potential shrapnel damage to the laser and associated optics, laser beams may be focussed through a relatively very small aperture before defocusing to form the spot. A high velocity stream of air may also be ejected under pressure from this aperture so as to

prevent ingress of debris. Such focussing and defocusing may serve to increase the divergence of a laser beam, due to the surface to be treated being remote from the focus, and induce or increase a spread of power density within a spot of incident laser light.

The use of spots, particularly overlapping spots, particularly sequential, of laser light to scabble a surface has been found to reduce the proportion of the treated surface which is treated by peripheral parts of a laser beam, i.e in which scabbling is inhibited because the power density of the laser does not reach the threshold for causing scabbling for the appropriate duration, and which may therefore inhibit further surface removal. Surprisingly, it has been found that whilst the area subjected to a lower incident laser beam power density, i.e. a power density below a critical threshold, is increased using the method of the invention as compared to a linearly scanned laser beam, the efficiency of surface removal is increased and a more even scabbled surface results.

Said plurality of spots of laser light may be arranged in a geometric arrangement. The geometric arrangement may be defined by the arrangement of the locations of the centres of the spots of laser light.

A centre of a spot of laser light may be defined as the geometric centre of the spot of incident laser light. A centre of a spot of laser light may be the highest power density region of an incident spot of laser light.

The geometric arrangement of a plurality of spots of laser light may be that of a simple geometric figure. Suitable simple geometric figures include triangles, rectangles, rhombi, pentagons, hexagons and the like. The simple geometric figure is preferably an equilateral triangle. The simple geometric figures may be tessellated, that is fit together exactly to cover a surface without gaps between the figures. The spots of laser light may be arranged as a series of geometric arrangements, such as a series of triangles, so that an array of spots of laser light is described on the surface by the method.

The extent of the overlap of overlapping spots of laser light may be such that for a given geometric arrangement, full coverage of the area within the whole spot pattern occurs during one treatment cycle. I.e. no area not, at one time during use of the method, exposed to laser light is present between the locations at which the spots of laser light are applied.

The spots of laser light may be ovoid. The spots of laser light may be ellipsoidal. The spots of laser light may be square or rectangular. The spots of laser light may be circular. The width of a spot of laser light may be a diameter of an incident spot of laser light. That width may be defined as that diameter of the spot exceeding a threshold power density level for scabbling. In one embodiment of the method of the present invention the distance between the centres of the spots of laser light may be in the range $4/7$ to $6/7$, and preferably $5/7$ (71%) of a spot diameter measured as that diameter of the spot exceeding a threshold power density level for scabbling.

A spot of laser light may be defined as an area of laser light incident upon a surface, wherein the area is an area in which the laser light is above a threshold power density level for causing scabbling. The diameter of a spot of laser light may be a diameter of that area of a spot of laser light in which the laser light is above a threshold power density level for causing scabbling.

In one embodiment of the present invention using a variable output YAG laser of up to 4 kW power the total diameter of an area of a surface upon which incident laser light falls may be from 20mm to 250mm in diameter and more preferably from 30mm to 130mm in diameter. In such an embodiment the width of the spot of laser light which is above the threshold power density level to cause scabbling, may correspondingly be from 30 to 80 mm, or from 50 to 75 mm in the preferred range. In general, larger spot sizes are preferred as they give more reproducible results.

If sequential spotting of laser light is used the time interval between successive spots of laser light may typically be between 0.1s and 2s. The time interval between each successive spot of laser light being applied may be substantially equal.

The time of irradiation of a surface location for any given spot of laser light may typically be between 1s and 30s. The time of irradiation for each successive spot of laser light applied may be substantially equal.

The duration of irradiation of a surface location for any given spot may be longer than the time interval between subsequent spots of laser light, preferably more than 5 times longer and most preferably 10 or more times longer.

5

The ratio of the spot treatment duration to the time interval between successive treatment spots in the case of laser scabbling is therefore over one million times more than is typical for a pulsed laser as described, for example, in GB 2316528. The time delay between adjacent spots when using the method of the invention is dictated primarily by the traversal speed of the laser deployment device, such as a robot arm. Optionally the laser may remain switched on during the traverse motion. Whereas in the case of a pulsed laser system the delay between pulses, typically less than 0.005s, is required to allow the laser to 'charge' and for the power to build up to the required level.

10

15

The average power density found in the method of the invention to produce optimum scabbling results for a Portland cement based concrete surface is of the order of $100\text{W}/\text{cm}^2$, based upon sequential spotting of laser light using a 70mm diameter spot, and a treatment time of 15-20 seconds per spot with a 3kW YAG laser. The average power density used will increase when using smaller spots, and may be nearly double when using a 40mm diameter spot of light from an equivalent laser, with a corresponding decrease in treatment time to approximately 3 seconds.

25

The optimum average power density and duration chosen for a spot of laser light represents a trade off between the proportion of the spot surface area which is above the threshold power density for scabbling, the desired

30

removal rate and the desired removal efficacy (e.g. no melting, or no creation of adjacent areas potentially resistant to scabbling), among other factors.

5 Any suitable method of creating individual spots of laser light for laser irradiation may be used. A continuous laser beam may be interrupted by a shutter or the beam may be turned on and off. More than one laser source may be used.

10

Any suitable method for moving the individual spots of laser light relative to the material being scabbled may be used including moving the laser, moving the object to be scabbled, moving a laser light conduit (such as a
15 fibre-optic cable) or the employment of optical methods such as mirrors and the like. It is optionally within the scope of the invention to move a beam, without turning it off, at such a velocity that the beam has a negligible residence time between individual spots of laser light in
20 proportion to the treatment time for each spot, such that individual successive incident spots of laser light are effectively created.

The spots of laser light irradiation for use in the
25 invention may have an uneven power density within the area of a spot.

A laser light source for use in the invention may typically be of total continuous power from 0.5 kW to 4
30 kW. Despite optionally being turned off during the motion between spots, this power is delivered substantially constantly over time. The laser is therefore not a

'pulsed laser' in the sense used in the technical field of laser technology.

5 A threshold power density for surface removal by scabbling for concrete may typically be in the range of $50\text{W}/\text{cm}^2$ to $80\text{W}/\text{cm}^2$ depending upon the surface to be treated, i.e. a value of $70\text{W}/\text{cm}^2$ or thereabouts.

10 The power of the laser, the size of the incident spot of laser light and the residence time of the spot of laser light are interrelated and for any given surface will be optimised so as to achieve the most effective surface removal. The interrelationships of the above factors are governed by established physical laws known to persons
15 skilled in the art.

A suitable laser source may be a Yttrium Aluminium Garnet (YAG) laser, a diode laser array or a fibre laser. The beams of laser light sources for use in the invention may
20 have a non-uniform power density in cross-section.

A range of different removal depths is obtainable in a single pass of an array of laser beam spots. A single treatment spot can remove anywhere between 1 and 30mm of
25 material at the deepest point. However, this depth will generally not be consistent across each treatment spot, typically showing a crater type geometry particularly with deeper scabbling. It has been found that concrete removal depths of about 1mm to 30mm may be achieved on a
30 surface, the coverage of which is carried out using a single array of spots of laser light according to the method of the invention.

Multiple passes each comprising an array of spots of laser light may be applied subsequent to one another to a surface to achieve a greater depth of surface removal by removing several layers of material in a sequential manner. The array of spots of laser light for subsequent irradiations may be placed out of alignment with a previous array. The location of spots of laser light, of sequential arrays applied to a given area may optionally be placed at the interstices of previous arrays, so as to define a three dimensional matrix.

The laser beam may be transmitted to a delivery head by means of a fibre optic cable. The laser beam may be alternatively described as laser light or laser radiation.

A delivery head for projecting a laser beam onto a surface to be treated may comprise focussing optics to focus the beam through a focal point. The optics may include means for changing the direction of the laser light through a right angle. The beam and any optics may be shrouded up to the focal point. The shroud may be frusto-conical. After the focal point the beam may diverge before impinging upon a surface to be treated. The surface to be treated may be 270mm from the focal point when optics of focal length 120mm are used giving a spot of incident laser light of around 70mm diameter on the surface to be treated.

Suitable laser equipment for practising the invention is supplied by TRUMPF GmbH and Co. KG. of Stuttgart, Germany. The laser delivery head may be deployed and guided by a robotic arm.

The laser beam may effect surface removal by the effects of thermal shock. The method of the invention may give no or negligible surface removal by melting or vaporisation
5 of the surface being treated.

The method may comprise a step of wetting the surface to be treated before irradiation with the laser beam.

10 The method may comprise a step of coating the surface to be treated before irradiation with laser light. Examples of suitable coatings are described in EP 0 653 762 A1.

The presence of radionuclides may affect the nature of
15 the scabbling process and the adsorption or absorption of incident laser radiation.

The method of the invention may typically be used for decontamination in conjunction with fume extraction, dust
20 or solids collection and other subsidiary protective processes to prevent the spread of any contamination, particularly where radioactivity is involved.

The surface for treatment according to the method of the
25 invention may be an inorganic non-metallic surface such as a concrete, i.e. a cement, e.g. a Portland cement matrix having aggregate therein. The surface may alternatively comprise a natural stone such as limestone, for example, or an engineered ceramic material such as
30 brick.

Brief description of the drawings

In order that the present invention may be more fully understood, examples will now be given by way of illustration only, with reference to the accompanying drawings, in which:

Figure 1 shows a schematic representation of power density across the width of a laser beam;

10

Figure 2 shows a schematic representation of an incident spot of laser light;

Figure 3 shows schematically a known method of laser scabbling comprising scanning a laser beam over a surface to be scabbled;

15

Figure 4 shows schematically an example of a pattern of spots of laser light for scabbling a surface in accordance with the invention;

20

Figure 5 shows schematically detail of the example shown in Figure 4 of a pattern of laser light irradiation in accordance with the present invention shown in;

25

Figure 6 shows schematically a further example of a pattern of laser light irradiation of a surface in accordance with the present invention;

Figure 7 shows schematically a yet further example of a pattern of laser light irradiation of a surface in accordance with the present invention; and

30

Figure 8 which shows a schematic representation of laser equipment suitable for use in the method of the invention.

- 5 In the accompanying figures like features are denoted by like reference numerals.

Description of preferred embodiments of the invention

- 10 A beam of laser light may be non-uniform in power density across a width of the beam. A schematic representation of power density across a laser beam is shown in Figure 1. Figure 1 depicts a graph 2 with a y axis of laser power density (I) and an x axis of distance (d) across the
- 15 beam. The curve 4 describes a quasi-Gaussian type power distribution from which it may be seen that the laser beam has a central area 16 of highest power density. The curve may be divided into two portions, the boundary between being defined by a threshold power density level
- 20 18. A portion 6 of the curve 4 above this power density threshold represents part of the laser beam capable of giving rise to scabbling of a surface, the portion 8 below represents an area not capable of giving rise to scabbling of such a surface. However, the low power
- 25 density portion 8 may give rise to surface modification which makes the surface resistant to scabbling by subsequent passes with a laser beam, even if that subsequent beam has a power density above the threshold
- 18.

30

Figure 2 depicts a representation of a laser beam, of uneven power density, such as described in Figure 1 when impinged, orthogonally, upon a surface. The surface, such

as one to be scabbled, is represented here and in other diagrams by the plane of the paper. The spot of laser light 20 comprises a centre 12 of highest power density and an immediately surrounding area 16 of high power density. The centre point 12, and area 16, forms part of area 24 wherein the light is above a threshold power density 18 for scabbling. Towards the periphery of the spot of laser light scabbling may be less effective (i.e. less material may be removed) until a boundary 14 is reached which corresponds to the threshold power density 18 for effecting scabbling. A further area 26 of low incident power exists between the first boundary 14 and a nominal outer boundary of the beam and is described by line 28 beyond which point incident power is very low, such as may be due to scattering, for example.

In the prior art an incident spot of laser light may be used to scabble a surface by traversing that surface in a known raster scan pattern 32. Figure 3 schematically depicts features 30 of such a method. The incident laser spot 20 moves over the surface in a raster scan pattern traced by the centre of the spot 12 along a line 32. The surface impinged upon by the high power density region of the spot at and within the boundary 14 scabbles. That impinged upon by the low power density region of the area of laser light 26 does not scabble but the surface is modified to varying degrees by effects such as relaxation, dehydration and chemical change. This occurs as the incident beam 20 traverses a first track 37, area 38 of the spot leaving modified, but un-scabbled surface area 36. Other surface area traversed by the low power density region of the laser light is also traversed by the higher power density region and thus scabbles.

Subsequently the laser spot traverses a second, adjacent, track 39. The surface impinged upon by the high power density region 24' of the spot 20' generally scabbles. However, surface area 36 substantially resists scabbling even though it is impinged by the high power density region 24' of the incident laser light. This is a significant disadvantage with current laser scabbling methodology.

10 The method of the invention relates to an improved method of treating a surface to be scabbled.

Figure 4 shows a pattern 40 of spot irradiation for the scabbling of a surface in accordance with the invention. A laser beam (not shown) is made to momentarily impinge as a spot 20 of light on a concrete surface to be scabbled (as represented by the plane of the paper) for 15s. The spot is then turned off, the laser moved, and a subsequent spot 20'' irradiated for the same length of time in an adjacent position. The spot is then turned off and a further spot 20''', overlapping spots 20 and 20'', is then irradiated. Still further spots of laser light as indicated by other circles are then irradiated. An array of spots of laser light is therefore built up as indicated. This may be visualised by identifying the centres of spots 12, 12'', 12'''. Joining the centres of such spots of laser light with notional lines 42 to establish a geometric shape, in this example represented as an equilateral triangle 44. This is an example of a simple geometric shape as referred to previously.

Detail of the effects of scabbling as illustrated in Figure 4 are shown in Figure 5. An initial spot of laser

light 20 causes scabbling in area 24. Area 26, of power density below the threshold power density for scabbling may start to become modified in such a way as to inhibit scabbling. The incident laser light is then moved to a
5 second location 20'' and further scabbling in area 24' occurs. Area 24' encompasses area 52 and any difficulty in scabbling due to prior irradiation with area 26 is overcome with the high power, higher near the centre 12'', area of incident laser light 24'. The relatively
10 small area indicated at 54 is further irradiated with lower power density laser light and may become difficult to scabble. However, when the incident spot of laser light is moved to location 12''' the potentially difficult to scabble small area 54 is located near the
15 highest power density part 16 of the laser spot 20''' and is given a higher incident power density than the threshold power density for scabbling present along boundary 14'''. The method of irradiating a surface for scabbling according to the method of the invention
20 therefore enables the highest power density region of an incident laser beam to impinge upon that part of a surface to be scabbled that is most likely to be resistant to scabbling.

25 As scabbling of the surface occurs with each spot a layer of the surface of the concrete is thereby systematically detached. The detached material may be ejected with some force or may be removed by conventional air pressure, vacuum or alternative methods and collected.

30

In alternative uses of the method of the invention alternative permutations of spot irradiation sequences may be used. Examples of such sequences are illustrated

in Figures 6 and 7. In Figure 6 a pattern of laser spot irradiation 60 is shown. The method comprises irradiating sequential spots of light 20, 20'' and so on along in an extended linear path 62 to scabble a line along the surface. A similar parallel row 63 of spots of laser light, offset by about a radius of the spots in a longitudinal direction from the first row of spots are then used to scabble the surface. Further rows, such as row 64 are then added to further scabble the surface. As the centres of the spots of laser light in a further row 63 are placed near the indentations 66 in an adjacent track 62 even scabbling of the surface occurs giving a relatively even surface and concentrating the most effective part of a laser spot for scabbling at or near regions 66 (c.f. combined regions 52 and 54) least likely to scabble.

A further pattern of irradiation of a surface with spots of laser light for effecting scabbling is shown in Figure 7. Sequential spots of laser light 20, 20'' and 20''' are used to irradiate the surface for scabbling. The sequence of spots follows the sequence indicated by lines 70, 72, 74, 76 and describes a herring-bone pattern upon the surface being scabbled. This variant of the method of the invention has the advantage that areas 66 are irradiated for scabbling soon after their creation by earlier spots of laser light in the sequence (20, 20'', 20''' etc).

A schematic representation of laser equipment suitable for use in the method of the invention is shown in Figure 8. A laser light source 100, emits laser light which may be channelled along a fibre optic channel 102 to focussing optics 104. The focussing optics comprise

lenses to focus the laser light to a focus 106. The laser light is shrouded by a frusto-conical shroud 108, one end 110 of which surrounds the focal point of the laser light. The shroud serves to protect the optics and other
5 components and forms part of an overall protective shroud (not shown) of the equipment. Compressed air is ejected at high velocity through the end of the shroud 110 to also stop ingress of debris such as fumes and particles. Outside the equipment the laser light diverges 112 and
10 impinges upon a surface to be treated 114.

The laser equipment may be mounted on a robotic arm for movement about a surface to be scabbled. Alternatively a robotic arm may move a laser head for emitting laser
15 light on to a surface to be scabbled wherein the head is connected to a stationary laser source by a fibre optic cable. Other deployment means may also be envisaged.

In use of a laser beam otherwise in accordance with the
20 invention interruption of the laser beam, e.g. by a shutter or by turning the continuous laser on and off, such as to not significantly affect the power density requirements is still considered within the scope of the invention.

Claims

1. A method of treating a surface for the removal of a surface portion comprising the step of irradiating the surface with laser light, characterised in that the irradiation is effected by covering said surface in a plurality of discrete spots of laser light having an average power density per spot of up to 200 W/cm².
2. A method of treating a surface according to claim 1 wherein the spots of laser light overlap.
3. A method of treating a surface according to either claim 1 or claim 2 wherein said plurality of spots of laser light are arranged in a geometric arrangement defined by the locations of centres of the spots of laser light.
4. A method of treating a surface according to claim 3 wherein the geometric arrangement of a plurality of spots of laser light is that of a simple geometric figure.
5. A method of treating a surface according to claim 4 wherein the simple geometric figure is chosen from the group consisting of triangles, rectangles, rhombi, pentagons, and hexagons.
6. A method of treating a surface according to claim 5 wherein the simple geometric figure is an equilateral triangle.

7. A method of treating a surface according to any one of claims 4, 5 or 6 wherein the simple geometric figures are tessellated.
- 5 8. A method of treating a surface according to any one of claim 2 to 7 wherein the extent of overlap of overlapping spots of laser light are such that no area not, at one time during use of the method, exposed to laser light is present between the locations of the
10 spots of laser light.
9. A method of treating a surface according to any previous claim wherein the spot of laser light is circular.
15
10. A method of treating a surface according to claim 9 wherein a distance between the centres of the spots of laser light is in the range $\frac{4}{7}$ to $\frac{6}{7}$ of the diameter, above a threshold power density level for
20 scabbling, of the circular spot of laser light.
11. A method of treating a surface according to any previous claim wherein the spots of laser light are defined as an area of laser light incident upon a
25 surface, wherein the area of laser light is that area above a threshold power density level for causing scabbling.
12. A method of treating a surface according to any
30 previous claim wherein the incident laser light has an incident power density range of $30\text{W}/\text{cm}^2$ to $200\text{W}/\text{cm}^2$.

13. A method of treating a surface according to any previous claim wherein each spot of laser light irradiates the surface for a duration between 1s and 30s.
- 5
14. A method of treating a surface according to any previous claim wherein the spots of laser light for use in the invention have an uneven power density across the beam.
- 10
15. A method of treating a surface according to any previous claim wherein multiple arrays of spots of laser light are applied subsequent to one another to a surface to achieve a greater depth of surface removal by removing layers in a sequential manner.
- 15
16. A method of treating a surface according to claim 15 wherein the location of spots of laser light of sequential arrays are placed at the interstices of previous arrays, so as to define a three dimensional matrix.
- 20
17. A method according to any previous claim wherein the laser is an Yttrium Aluminium Garnet (YAG) laser, diode laser or fibre laser.
- 25
18. A method according to any previous claim wherein the surface is a concrete surface.
- 30
19. A method according to claim 18 wherein the surface is a cement or concrete surface contaminated with radionuclides.

20. A method according to any previous claim wherein the surface portion is removed by the effects of thermal shock.
- 5 21. A method of treating a surface for the removal of a surface portion substantially as hereinbefore described with reference to the accompanying description and any one of drawings 4, 5, 6 and 7.

Figure 1

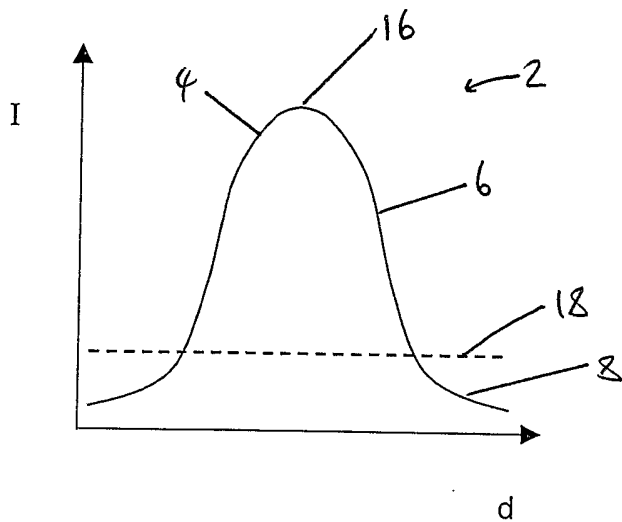

Figure 2

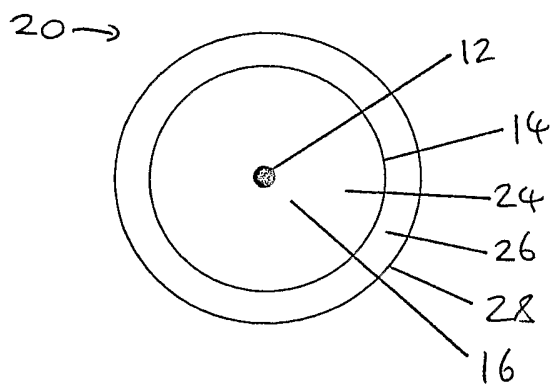
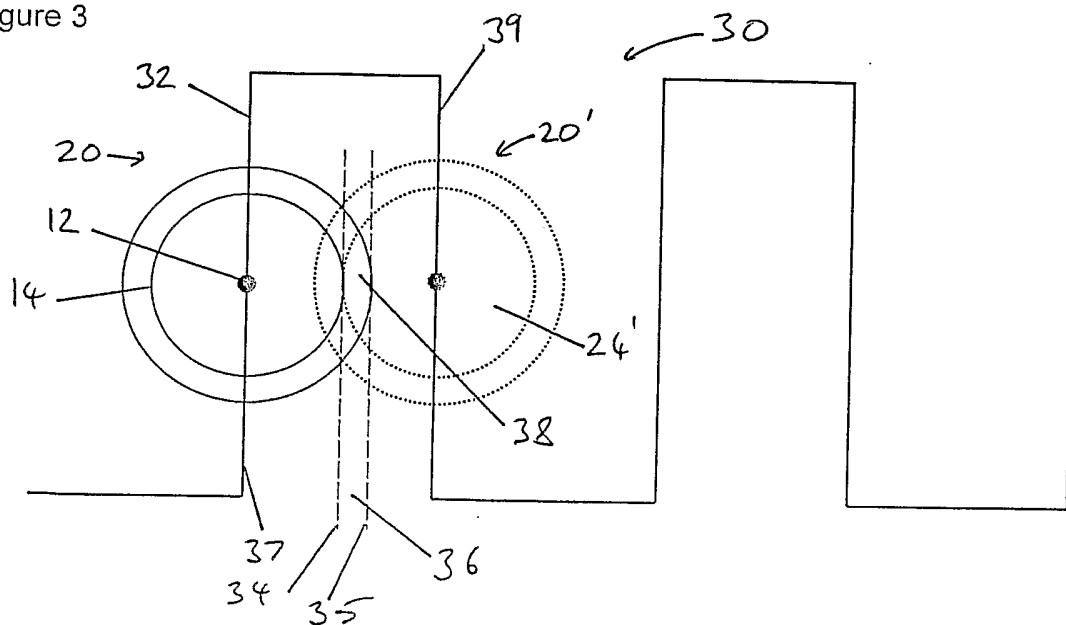

Figure 3



2 / 4

Figure 4

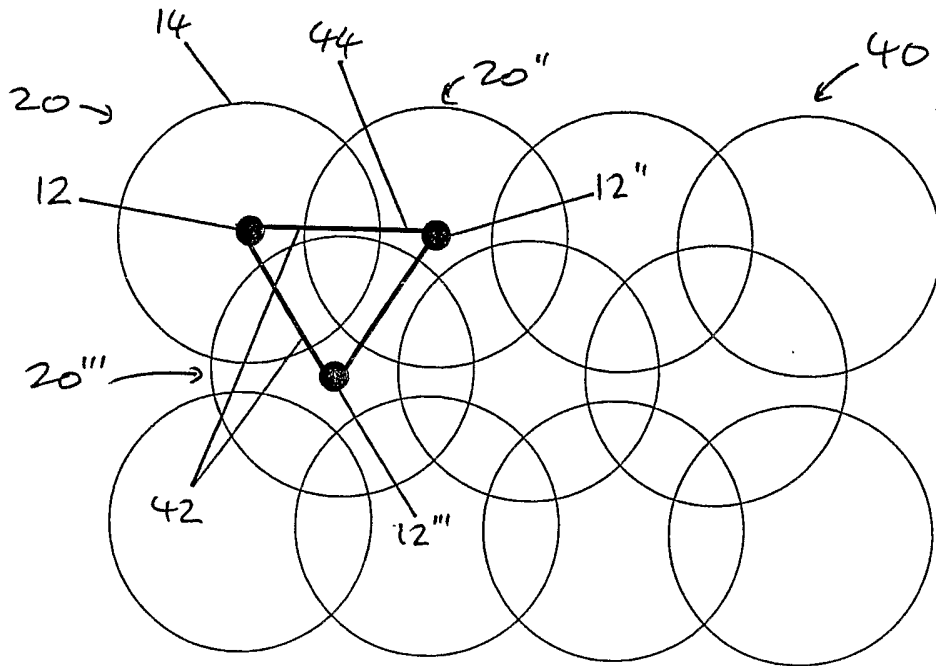

Figure 5

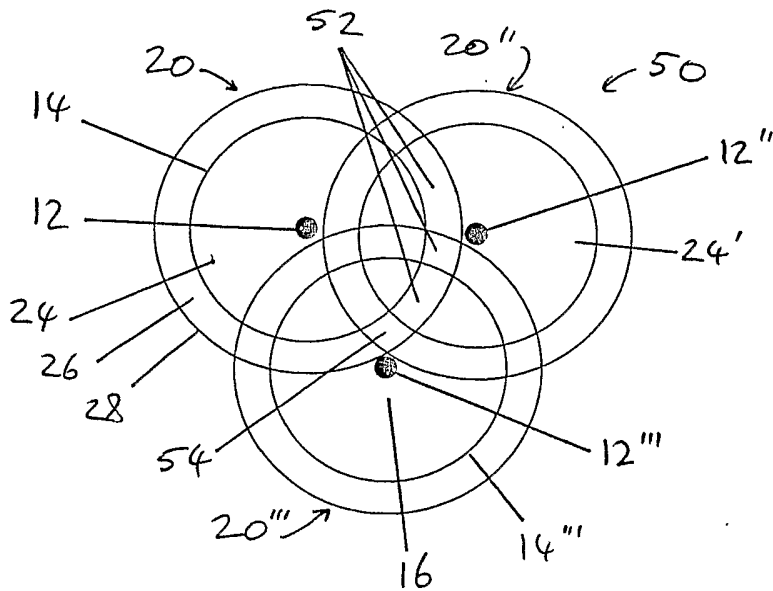

Figure 6

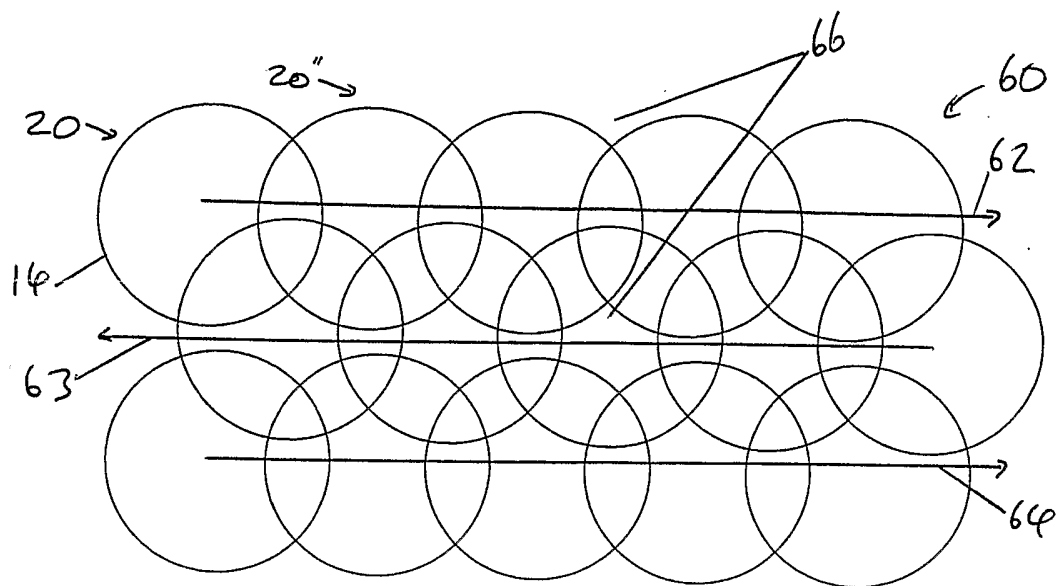

Figure 7

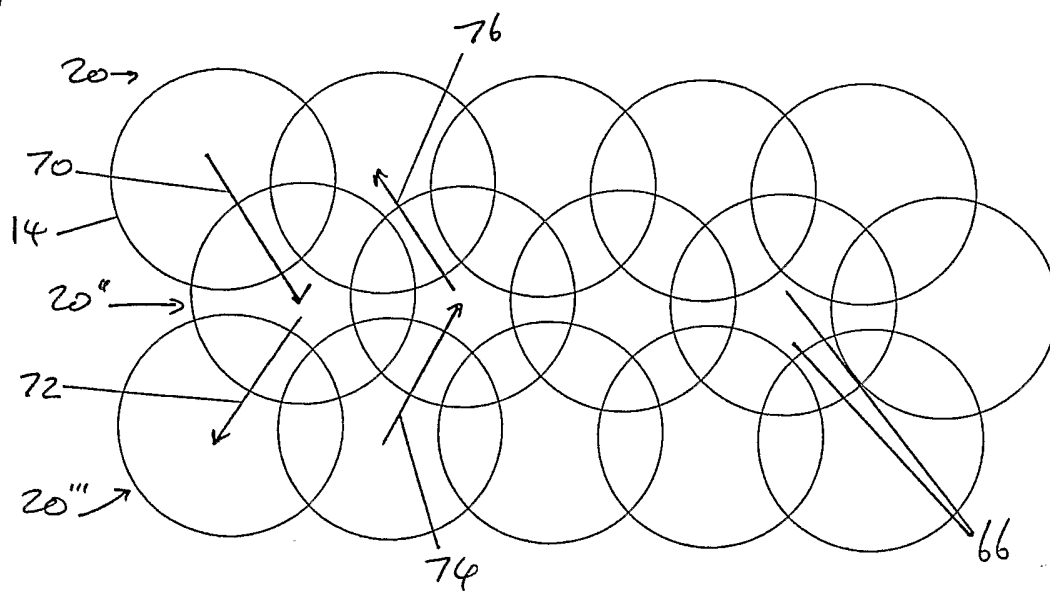
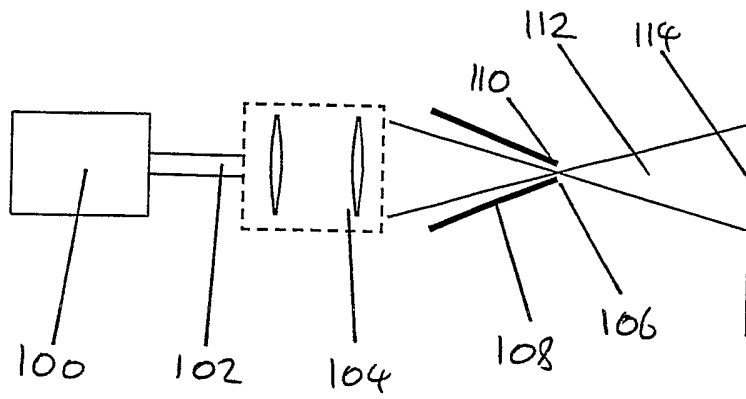

Figure 8



INTERNATIONAL SEARCH REPORT

International Application No
PCT/GB 03/04103

A. CLASSIFICATION OF SUBJECT MATTER IPC 7 B08B7/00 G21F9/00		
According to International Patent Classification (IPC) or to both national classification and IPC		
B. FIELDS SEARCHED		
Minimum documentation searched (classification system followed by classification symbols) IPC 7 B08B G21F		
Documentation searched other than minimum documentation to the extent that such documents are included in the fields searched		
Electronic data base consulted during the international search (name of data base and, where practical, search terms used) EPO-Internal		
C. DOCUMENTS CONSIDERED TO BE RELEVANT		
Category *	Citation of document, with indication, where appropriate, of the relevant passages	Relevant to claim No.
X	EP 0 653 762 A (BRITISH NUCLEAR FUELS PLC) 17 May 1995 (1995-05-17) cited in the application column 2, line 57 -column 3, line 40 column 6, line 9-28; figure 2 ---	1-9, 11, 12, 17-20
X	FR 2 760 403 A (LASERALP IND) 11 September 1998 (1998-09-11) page 2, line 28 -page 3, line 22; figures 1-3 ---	1-12, 15, 17, 20
X	EP 0 642 846 A (ONET SA) 15 March 1995 (1995-03-15) column 4, line 49 -column 5, line 22 column 13, line 2-17; figures 1-3 --- -/--	1-12, 15, 16, 20
<input checked="" type="checkbox"/> Further documents are listed in the continuation of box C. <input checked="" type="checkbox"/> Patent family members are listed in annex.		
* Special categories of cited documents :		
A document defining the general state of the art which is not considered to be of particular relevance *E* earlier document but published on or after the international filing date *L* document which may throw doubts on priority claim(s) or which is cited to establish the publication date of another citation or other special reason (as specified) *O* document referring to an oral disclosure, use, exhibition or other means *P* document published prior to the international filing date but later than the priority date claimed	*T* later document published after the international filing date or priority date and not in conflict with the application but cited to understand the principle or theory underlying the invention *X* document of particular relevance; the claimed invention cannot be considered novel or cannot be considered to involve an inventive step when the document is taken alone *Y* document of particular relevance; the claimed invention cannot be considered to involve an inventive step when the document is combined with one or more other such documents, such combination being obvious to a person skilled in the art. *&* document member of the same patent family	
Date of the actual completion of the international search <p style="text-align: center; font-size: 1.2em;">30 January 2004</p>	Date of mailing of the international search report <p style="text-align: center; font-size: 1.2em;">11/02/2004</p>	
Name and mailing address of the ISA European Patent Office, P.B. 5818 Patentlaan 2 NL - 2280 HV Rijswijk Tel. (+31-70) 340-2040, Tx. 31 651 epo nl, Fax: (+31-70) 340-3016	Authorized officer <p style="text-align: center; font-size: 1.2em;">Jandl, F</p>	

INTERNATIONAL SEARCH REPORT

International Application No

PCT/GB 03/04103

C.(Continuation) DOCUMENTS CONSIDERED TO BE RELEVANT		
Category °	Citation of document, with indication, where appropriate, of the relevant passages	Relevant to claim No.
X	WO 97 48536 A (BRITISH NUCLEAR FUELS PLC ;LAWRENCE JONATHAN (GB); LI LIN (GB); SP) 24 December 1997 (1997-12-24) page 5, line 1-9 page 10, line 1 -page 11, line 24 page 12, line 29 -page 13, line 8; figures 1,2 -----	1-12,14, 17,18,20
A	EP 0 724 929 A (TOKYO SHIBAURA ELECTRIC CO) 7 August 1996 (1996-08-07) column 3, line 16-49 column 8, line 12-24 column 10, line 32 -column 11, line 19 column 13, line 35 -column 14, line 46 column 16, line 22-33; figures 1-6 -----	1-11, 14-17,20

INTERNATIONAL SEARCH REPORT

International application No.
PCT/GB 03/04103

Box I Observations where certain claims were found unsearchable (Continuation of item 1 of first sheet)

This International Search Report has not been established in respect of certain claims under Article 17(2)(a) for the following reasons:

1. Claims Nos.:
because they relate to subject matter not required to be searched by this Authority, namely:

2. Claims Nos.: 21
because they relate to parts of the International Application that do not comply with the prescribed requirements to such an extent that no meaningful International Search can be carried out, specifically:
see FURTHER INFORMATION sheet PCT/ISA/210

3. Claims Nos.:
because they are dependent claims and are not drafted in accordance with the second and third sentences of Rule 6.4(a).

Box II Observations where unity of invention is lacking (Continuation of item 2 of first sheet)

This International Searching Authority found multiple inventions in this international application, as follows:

1. As all required additional search fees were timely paid by the applicant, this International Search Report covers all searchable claims.

2. As all searchable claims could be searched without effort justifying an additional fee, this Authority did not invite payment of any additional fee.

3. As only some of the required additional search fees were timely paid by the applicant, this International Search Report covers only those claims for which fees were paid, specifically claims Nos.:

4. No required additional search fees were timely paid by the applicant. Consequently, this International Search Report is restricted to the invention first mentioned in the claims; it is covered by claims Nos.:

Remark on Protest

- The additional search fees were accompanied by the applicant's protest.
- No protest accompanied the payment of additional search fees.

FURTHER INFORMATION CONTINUED FROM PCT/ISA/ 210

Continuation of Box I.2

Claims Nos.: 21

No features are given in claim 21

The applicant's attention is drawn to the fact that claims, or parts of claims, relating to inventions in respect of which no international search report has been established need not be the subject of an international preliminary examination (Rule 66.1(e) PCT). The applicant is advised that the EPO policy when acting as an International Preliminary Examining Authority is normally not to carry out a preliminary examination on matter which has not been searched. This is the case irrespective of whether or not the claims are amended following receipt of the search report or during any Chapter II procedure.

INTERNATIONAL SEARCH REPORT

Information on patent family members

International Application No

PCT/GB 03/04103

Patent document cited in search report		Publication date	Patent family member(s)	Publication date
EP 0653762	A	17-05-1995	DE 69409066 D1	23-04-1998
			DE 69409066 T2	13-08-1998
			EP 0653762 A1	17-05-1995
			JP 7209491 A	11-08-1995
			US 5538764 A	23-07-1996
FR 2760403	A	11-09-1998	FR 2760403 A1	11-09-1998
EP 0642846	A	15-03-1995	FR 2708877 A1	17-02-1995
			DE 69410900 D1	16-07-1998
			DE 69410900 T2	11-02-1999
			EP 0642846 A1	15-03-1995
			ES 2117236 T3	01-08-1998
WO 9748536	A	24-12-1997	DE 69719989 D1	24-04-2003
			EP 0912308 A1	06-05-1999
			WO 9748536 A1	24-12-1997
EP 0724929	A	07-08-1996	JP 3461948 B2	27-10-2003
			JP 8206869 A	13-08-1996
			CA 2168413 A1	01-08-1996
			DE 69612411 D1	17-05-2001
			DE 69612411 T2	06-12-2001
			EP 0724929 A2	07-08-1996
			US 6084202 A	04-07-2000
			US 5790620 A	04-08-1998