

A. WISNER.

Apparatus for Applying Button Staples to Shoes, &c.

No. 201,858.

Patented March 26, 1878.

FIG. 2.

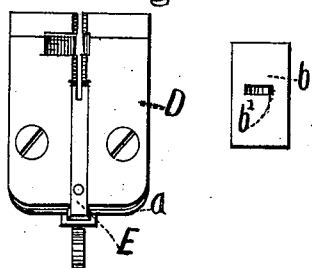

FIG. 1.

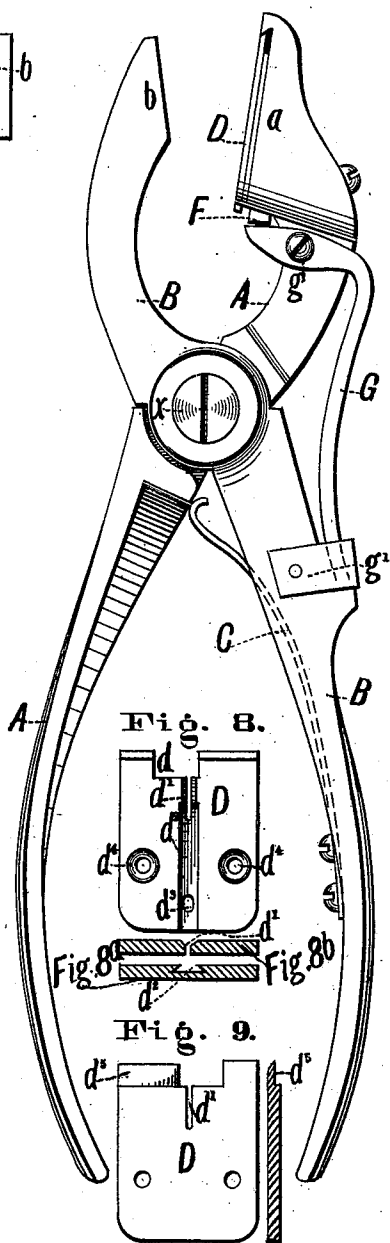

FIG. 3.

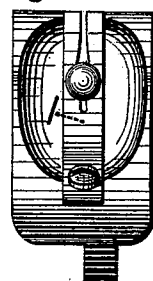

FIG. 4.

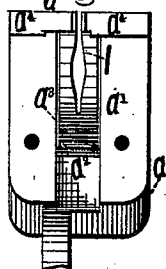

FIG. 5.

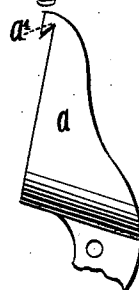

FIG. 6.

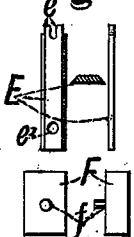

FIG. 7.

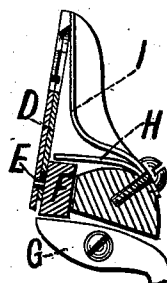

FIG. 8.

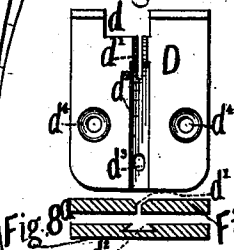
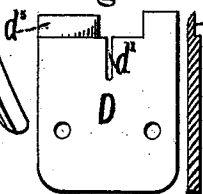

FIG. 9.



WITNESSES  
T. S. West,  
Cornelius Cox.

INVENTOR:  
ALBERT WISNER,  
BY  
A. W. Beadle & Co.  
ATTYS.

A. WISNER.  
Apparatus for Applying Button Staples to Shoes, &c.

No. 201,858.  
Fig. 10.

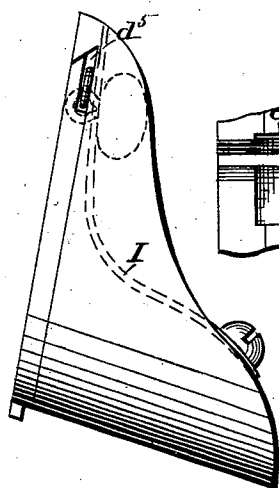

Patented March 26, 1878.

Fig. 11.

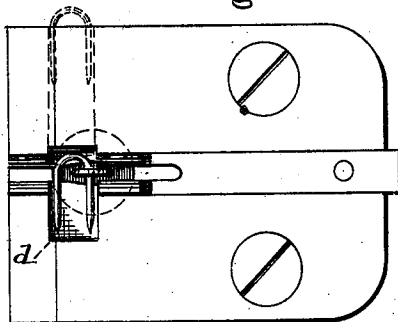

Fig. 13.

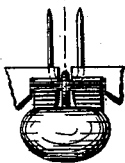
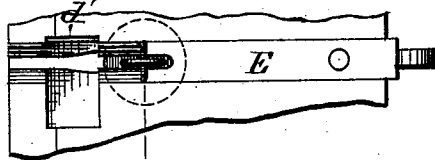

Fig. 12.

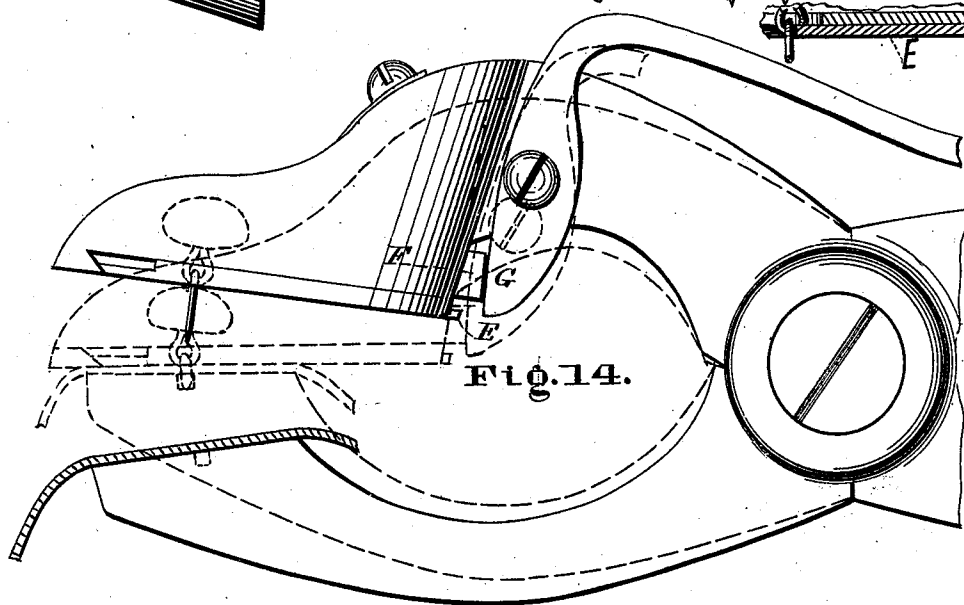
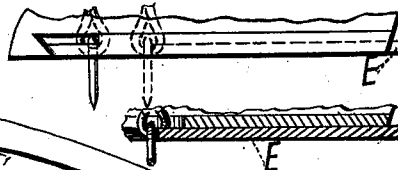
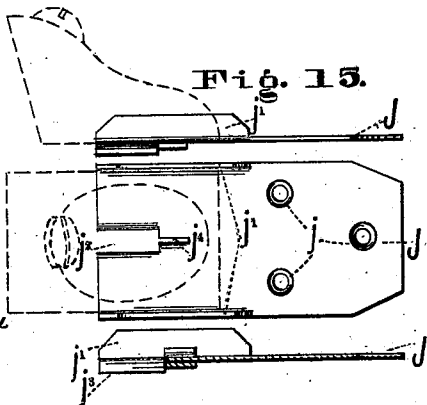

Fig. 14.

Fig. 15.



WITNESSES:

*J. S. West*  
*Cornelius Cox*

INVENTOR:  
ALBERT WISNER,  
BY  
*H. W. Beadler & Co.*  
ATTYS.

# UNITED STATES PATENT OFFICE.

ALBERT WISNER, OF BRIDGEPORT, CONNECTICUT.

IMPROVEMENT IN APPARATUS FOR APPLYING BUTTON-STAPLES TO SHOES, &c.

Specification forming part of Letters Patent No. **201,858**, dated March 26, 1878; application filed February 25, 1878.

*To all whom it may concern:*

Be it known that I, ALBERT WISNER, of Bridgeport, county of Fairfield, and State of Connecticut, have invented new and useful Improvements in Tools for Applying Button-Staples to Shoes; and I do hereby declare that the following is a full and exact description of the same, reference being had to the accompanying drawings, and to the letters of reference marked thereon.

This invention is an improved tool, which is specially designed for use in applying staples to shoes, for the purpose of securing thereto the ordinary buttons, in the manner described in my patent of December 11, 1877, No. 197,957.

Its novelty consists, mainly, first, in providing the tool with a proper slot or opening through a portion of the same, which is adapted to receive the staple and guide the same to the eye of the button; second, in the combination, with a peculiarly-constructed plate, having a recess adapted to receive the bend of the staple, of a sliding plate for clamping the staple and holding it in proper position while being applied to the shoe; third, in the combination, with the sliding clamping-plate, of a lever for actuating the same.

It consists, further, in certain details of construction, which, in connection with the foregoing, will be fully described hereinafter.

In the drawings, Figure 1 represents a side elevation of my improved tool. Fig. 2 represents plan views of the faces of jaws *a* and *b* detached; Fig. 3, a plan view of the rear side of jaw *b*; Fig. 4, a plan view of the face of jaw *a* with the plate D removed; Fig. 5, a side view of the same; Fig. 6, views of the parts E and F detached; Fig. 7, a longitudinal sectional elevation of the jaw *a*; Figs. 8 and 9, views of plate D removed; Figs. 10, 11, 12, 13, and 14, enlarged views of various parts illustrating the operation of the tool; and Fig. 15, a plate of peculiar construction, which may be employed in connection with the tool, if desired.

To enable others skilled in the art to make and use my invention, I will now proceed to describe the same fully and the manner of operation.

The tool, as a whole, resembles a pair of

pinchers in its general construction. A and B represent the two main parts, which cross each other at a common pivot-point, and are united together by means of the pivot-pin *x*, as shown. C represents a spring, of any proper construction, by means of which the handles of the tool are separated, when the spring is free to act for the purpose of holding open the jaws.

*a*, Figs. 1 and 4, represents the head or jaw of the part A, consisting of a block of any proper form, having an upper face, *a*<sup>1</sup>, Fig. 4, a central recess, *a*<sup>2</sup>, an elongated slot or opening, *a*<sup>3</sup>, and the bearing-shoulders *a*<sup>4</sup> *a*<sup>4</sup>, Figs. 4 and 5, separated by the open space *a*<sup>5</sup>, Fig. 4, as shown.

D, Figs. 8 and 9, represents a plate adapted in form and size to rest upon the face *a*<sup>1</sup> of the jaw *a*, which is provided with the transverse opening *d* at its front end, the central slot or opening *d*<sup>1</sup>, the central recess *d*<sup>2</sup>, having the elongated opening *d*<sup>3</sup>, and the screw-holes *d*<sup>4</sup>, by means of which it is adapted to be strongly secured to the face of the jaw.

*d*<sup>5</sup>, Fig. 9, represents a transverse recess formed at its front end on the lower side. The edges of the recess *d*<sup>2</sup>, Fig. 8<sup>a</sup>, are beveled, it will be observed, for the purpose of retaining properly in place the sliding piece E, hereinafter referred to, which moves therein. The edges, also, of the plate on each side of the central slot *d*<sup>1</sup>, Fig. 8<sup>b</sup>, in front of the recess, are beveled to permit the passage of the staple, as will be described hereinafter.

E, Fig. 6, represents the sliding piece before referred to, consisting of a metal bar, having inclined edges adapted to fit the corresponding edges of the recess *d*<sup>2</sup>, Fig. 8<sup>a</sup>, in which it slides, and at its front end projecting fingers *e*, and at its rear end the pin-opening *e*<sup>1</sup>, as described. F represents a block adapted to fit the recess *a*<sup>2</sup>, Fig. 4, of the part *a*, and slide freely therein, which is provided with a pin or stud, *f*, adapted to rest in the opening *e*<sup>1</sup> of the sliding piece E, as shown.

G, Figs. 1 and 7, represents a lever pivoted to the part A by the pin *g*, the long arm of which is bent at right angles and extended in a rearward direction, as shown. *g*<sup>1</sup> represents a proper socket-piece upon the arm, by means

of which the arm is properly held in place. The end of the short arm bears against the outer end of the sliding block F, as shown.

H, Fig. 7, represents a spring of any proper construction, the free end of which bears against the opposite end of the block F, and gives the same its proper return movement after it has been actuated by the lever.

I, Figs. 3, 4, and 7, represents a spring having a central slot, as shown, which is adapted, when the button is in place, to exert a pressure upon the staple, as will be described hereinafter. *b* represents the jaw of the part B, which is provided with the recess *b*<sup>1</sup>, having a curved bottom surface, as shown.

The parts, when united, are represented in Figs. 1 and 2. The front edges of the recess *d*<sup>2</sup> of the plate D and the opposite ends of the clamping-piece E form a rectangular recess or cavity, as shown in Fig. 2, which is adapted to receive the bend of the staple, as will be hereinafter described. The recess *d*<sup>5</sup> of the plate D forms, in connection with the face *a*<sup>1</sup> of the part *a*, a slot or passage-way, through which the staples pass to engage with the eye of the button, as will be described hereinafter.

The operation is substantially as follows: The tool being held in the position shown in Fig. 10, and a button having been inserted into the central slot in such manner as to bring the center of its eye in line below one side of the recess *d*<sup>5</sup>, a staple is inserted in the latter, points downward, as shown in Fig. 11, and released, when the same, falling by its own weight through the recess, is caught by the eye of the button, one of its legs passing through the same, as shown. The proper descent of the legs of the staple below the eye of the button is permitted by the transverse opening *d*, as shown.

The position of the tool now being changed, as shown in Fig. 12, the staple will hang from the eye in its proper position at right angles thereto. The button and attached staple are then carried backward in the central slot, as indicated in dotted lines, until the recess between the edges of the central slot *d*<sup>1</sup> and the clamping-plate E is reached, as shown in Fig. 13. In order to make this movement, the spring I is caused to yield sufficiently to permit the bend of the staple to slide along the beveled edges of the plate; but when the recess is reached the former reacts, and, drawing on the button, pulls the bend of the staple down into the recess for the purpose of properly holding the same.

The tool now may be applied to the shoe at the proper point, as indicated in Fig. 14, and the handles be brought together to accomplish the desired result. As soon, however, as the movement of the handles begins, the lever G is actuated to throw forward the sliding block F, and consequently, also, the clamping-piece E, which is attached thereto. By means of this action the bend of the staple is clamped

and strongly held before the points enter the leather.

By the continued movement of the handles the points are caused to pass through the leather and come in contact with the curved surface of the opposite jaw, by means of which they are properly clinched. By compressing the spring I, the staple may be moved out of its recess and slipped out of the slot, to disengage the shoe and the button from the tool.

Some of the advantages of the described construction are as follows: By means of the recess *d*<sup>5</sup> the staple is easily connected with the button-eye. By means of the spring I the staple is drawn down into the recess far enough to permit it to be properly supported. By means of the clamping-piece the staple is strongly held in its proper position, so that its proper entry into the leather is insured. A feeding-gage, which may be employed in connection with this tool, is represented in Fig. 15.

J represents a plate having screw-holes *j*, by means of which it may be strongly secured to any proper means of support. *j*<sup>1</sup> *j*<sup>1</sup> represent flanges extending upward in a vertical direction, which inclose sufficient space between them to permit the jaw *a* to slide snugly therein. *j*<sup>2</sup> represents a central slot, having the downwardly-extending flanges *j*<sup>3</sup>, adapted to guide the staple properly in its movement. *j*<sup>4</sup> represents a central stud projecting upward from the plate, which is adapted to bear against the eye of the button.

The operation will be readily understood. The staple having been caused to engage with the button-eye, as previously described, and as shown in full lines, Fig. 12, the jaw *a* is laid upon the plate and pressed forward until the button and staple are forced into their proper positions. The flange *j*<sup>1</sup> serves to guide the jaw properly in its movement, and the flanges *j*<sup>3</sup> the staple. The stud *j*<sup>4</sup> provides a bearing, by means of which the button is held as the jaw is moved.

Having thus fully described my invention, what I claim as new, and desire to secure by Letters Patent, is—

1. The clamping-tool provided with a central slot for the eye of the button and a side recess for delivering the staple to the latter, the arrangement being such that the eye will be held in proper position to receive the staple as the latter falls through the recess, as and for the purpose described.

2. In combination with the plate D, having a recess, as described, a movable clamping-piece for securing the staple therein, substantially as described.

3. In combination with the sliding piece E, the lever G and handle B for actuating the lever, substantially as described.

4. In combination with the plate D, having a central recess adapted to hold a button-eye, the spring I, adapted to draw the eye through the recess for the purpose of holding the sta-

ple in proper position, substantially as described.

5. In combination with the sliding piece and actuating-lever, the return-spring, substantially as described.

6. In combination with the plate E and block F, the actuating-lever G and handle B, substantially as described.

7. The tool described, consisting, essentially, of the jaws A and B, the jaw A having a central recess and sliding piece, E, actuated by the le-

ver G and the spring I, combined and arranged as and for the purpose set forth.

8. The feeding-gage having the central slot and flanges, substantially as described.

This specification signed and witnessed this 1st day of February, 1878.

ALBERT WISNER.

Witnesses:

W. L. SHERWOOD,  
ARTHUR ELWOOD.