



US 20060061506A1

(19) **United States**

(12) **Patent Application Publication**
Murphy

(10) **Pub. No.: US 2006/0061506 A1**

(43) **Pub. Date: Mar. 23, 2006**

(54) **METHOD AND APPARATUS FOR PROVIDING AN INTEGRATED COMMUNICATIONS, NAVIGATION AND SURVEILLANCE SATELLITE SYSTEM**

Publication Classification

(51) **Int. Cl.**
G01S 5/14 (2006.01)
(52) **U.S. Cl.** **342/357.01**

(76) **Inventor: Timothy A. Murphy, Lynnwood, WA (US)**

(57) **ABSTRACT**

Correspondence Address:
HARNES, DICKEY & PIERCE, P.L.C.
P.O. BOX 828
BLOOMFIELD HILLS, MI 48303 (US)

A system provides integrated communications, navigation and surveillance capabilities. The system includes a space segment having a plurality of satellites broadcasting multiple navigation signals and a communication signal. A user segment includes a user device that is operable to broadcast communication signals to the satellites and of using the navigation signals broadcast by the satellites to determine a position of the user device. The satellites are operable to receive the communication signals from the user device and determine a position of the user device based upon the received communication signals. The satellites broadcast one of the navigation signals and the communication signal at a same frequency. The navigation signal acts as a pilot tone for the system to acquire and synchronize the user device with the system.

(21) **Appl. No.: 11/205,918**

(22) **Filed: Aug. 17, 2005**

Related U.S. Application Data

(60) Division of application No. 10/738,314, filed on Dec. 17, 2003, now Pat. No. 6,963,304, which is a continuation of application No. 09/972,355, filed on Oct. 5, 2001, now Pat. No. 6,674,398.

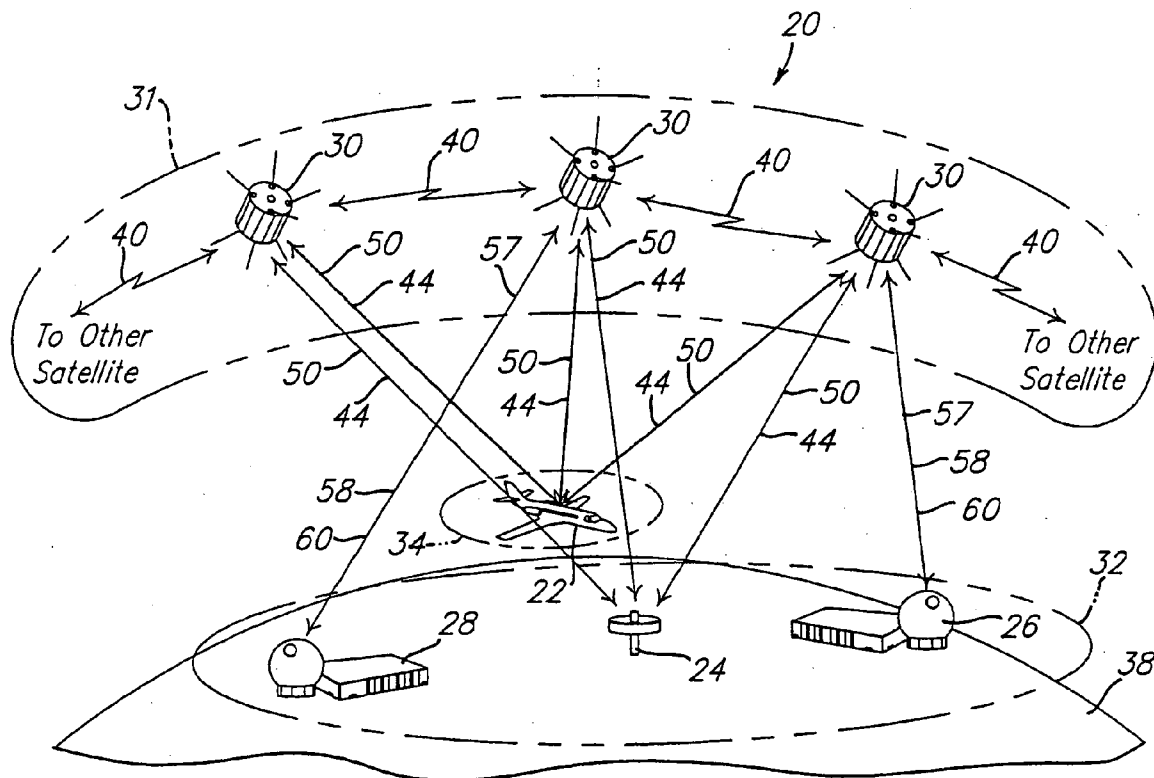

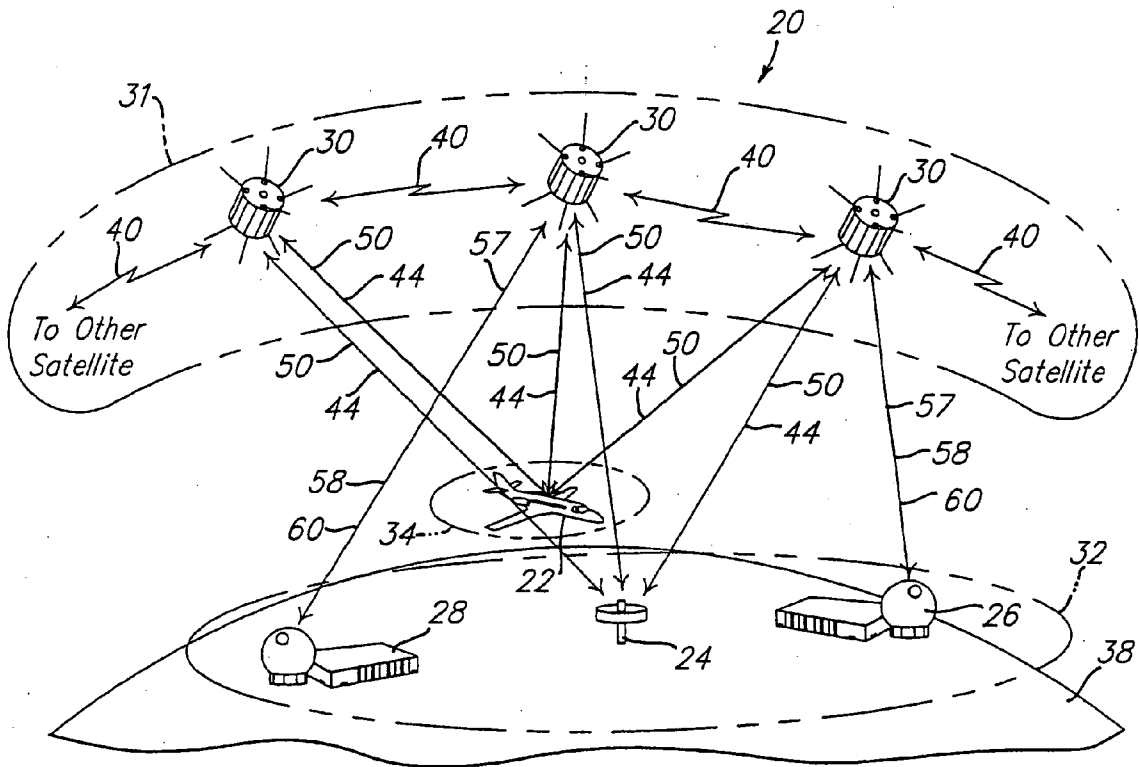

FIG. 1.

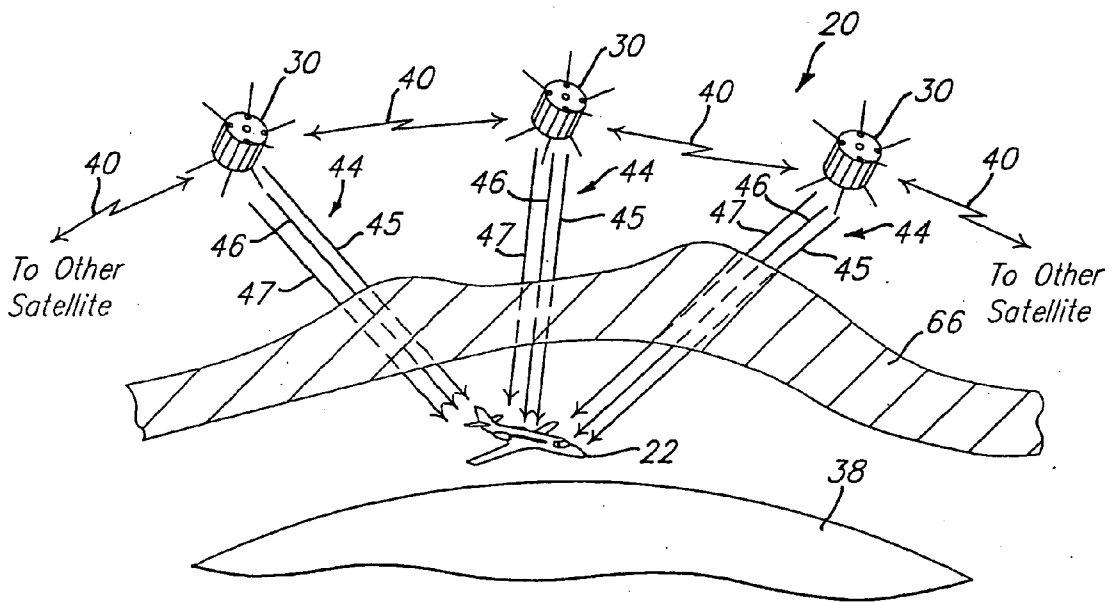

FIG. 2.

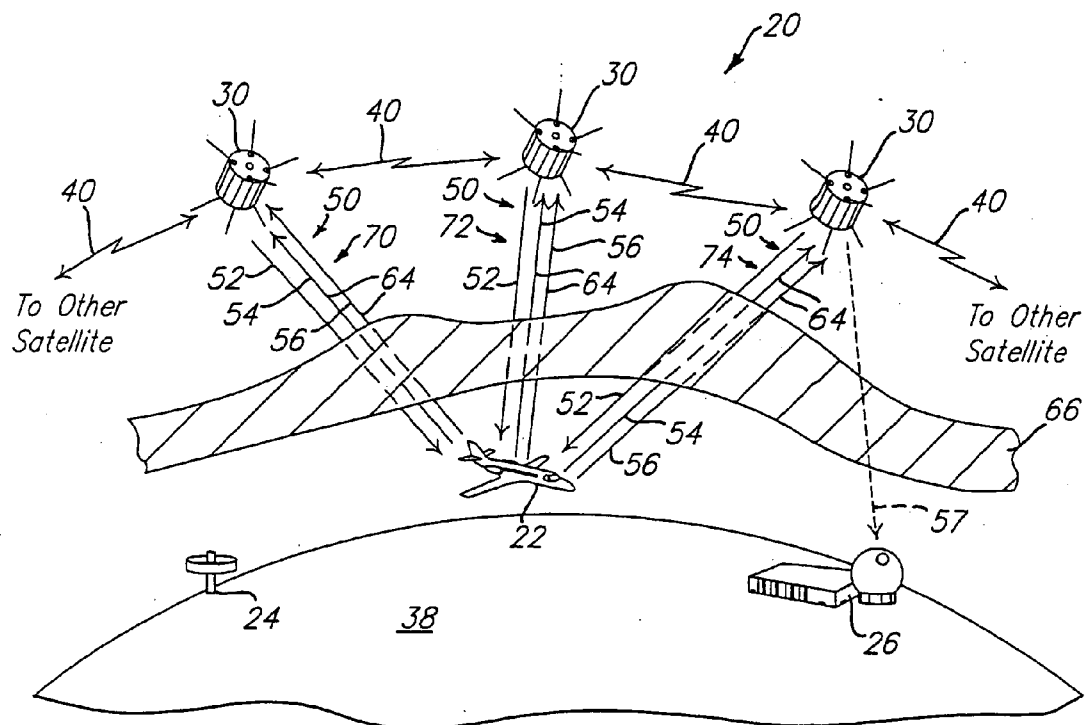

FIG. 3.

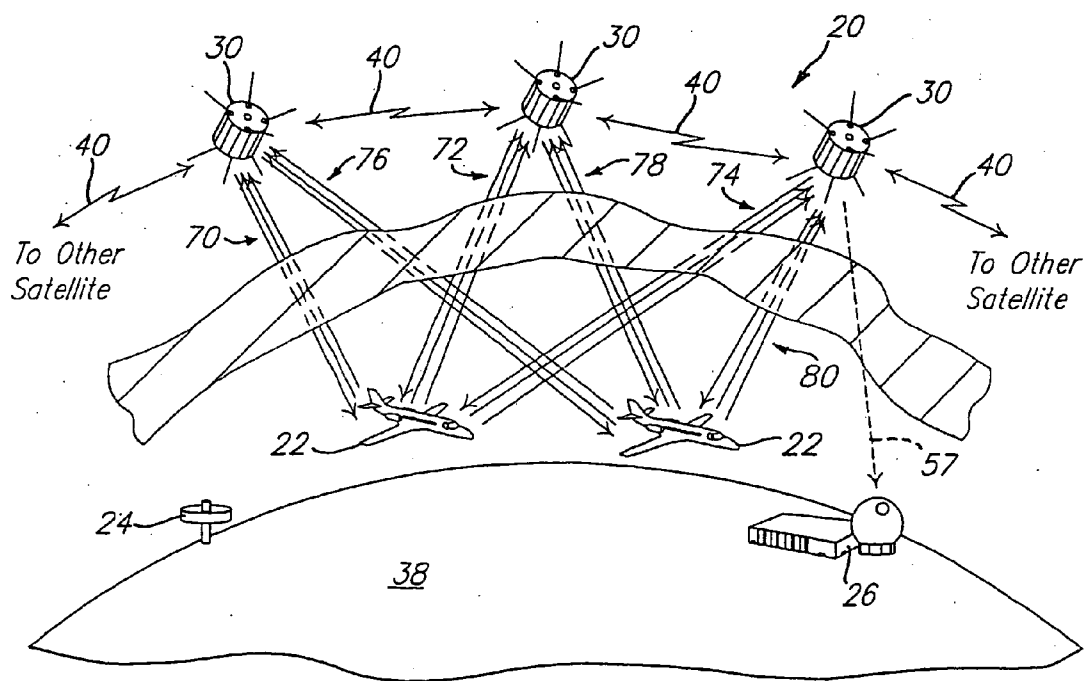

FIG. 4.

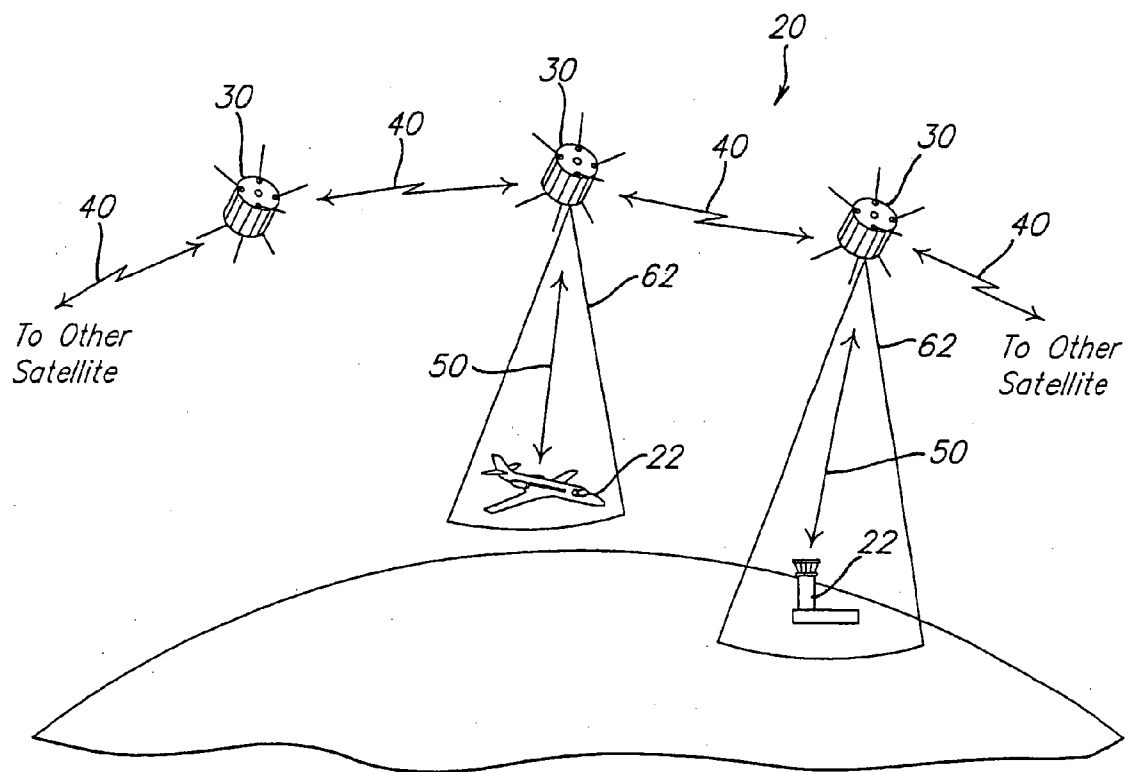

FIG. 5.

METHOD AND APPARATUS FOR PROVIDING AN INTEGRATED COMMUNICATIONS, NAVIGATION AND SURVEILLANCE SATELLITE SYSTEM

CROSS-REFERENCE TO RELATED APPLICATIONS

[0001] This application is a continuation of U.S. patent application Ser. No. 09/972,355 filed on Oct. 5, 2001, and now issued as U.S. Pat. No. _____, the disclosure of which is incorporated herein by reference.

FIELD OF THE INVENTION

[0002] The present invention relates to a global integrated communications, navigation and surveillance satellite system.

BACKGROUND OF THE INVENTION

[0003] Current satellite systems provide positioning and time information by broadcasting navigation signals to properly equipped users. For example, the US Global Positioning System (GPS) consists of 24 satellites orbiting the earth twice a day at an altitude of approximately twelve thousand miles, as well as a network of ground stations to monitor and manage the satellite constellation. The GPS satellites transmit continuous Navigation Data and Ranging (NDR) information 24 hours a day toward the earth. A GPS receiver which properly decodes, tracks and interprets these transmissions from the GPS satellites can compute the position of the GPS receiver as well as determine accurate time. The basic functioning of GPS and GPS receivers, is well known in the art. The GPS satellite system currently broadcasts for civilian use a Standard Positioning Service (SPS) on a single frequency (1575.42 MHz) called L1. The current GPS receivers and the GPS satellites are not capable of two-way communication with each other. GPS is a broadcast only service.

[0004] The GPS was conceived, designed and deployed as a military force enhancement. Consequently much of the capability of the GPS (i.e. the Precise Positioning Service or PPS) is not available to Civil users. Furthermore, even the GPS SPS service which is available to the civil community was not designed with adequate integrity, reliability or availability necessary to support safety of life civil applications. Furthermore, the SPS includes a relatively low power signal on only a single frequency and is consequently vulnerable to intentional or unintentional interference. These problems with the integrity and robustness of the civil GPS services are well known in the art.

[0005] As the SPS signals travel from the GPS satellites to the GPS receivers the SPS signals travel through the ionosphere which encircles the earth. The ionosphere acts as a dispersive medium and refracts the SPS signals as they travel through the ionosphere. As a result, the SPS signals do not appear to travel at the speed of light, which is assumed in the calculation of the position of the GPS receiver. The ionospheric induced delay in the reception of the SPS signals limits the accuracy of the determination of the position of the GPS receiver and is the largest location dependent error source in the calculation of the position of the GPS receiver. Therefore, the use of the GPS SPS signals to compute a position of the GPS receiver has limited

accuracy and cannot be used for applications requiring a high degree of precision in the determination of the position of the GPS receiver.

[0006] To overcome the aforementioned shortcomings of the GPS, a number of space based augmentation systems (SBAS) are under development. For example, there are currently three SBAS systems under development worldwide: the Wide Area Augmentation System (WAAS) under development by the Federal Aviation Administration; the European Geostationary Navigation Overlay Service (EGNOS) under development by the European Space Agency in conjunction with EURO CONTROL and the European Union; and the MTSAT Satellite Augmentation System (MSAS) under development by the Japanese Civil Aviation Bureau. These SBASs provide for a way to measure and correct for the ionospheric delay caused by the SPS signals traveling through the ionosphere on its way toward earth and provide for basic integrity monitoring of the GPS SPS service sufficient to meet the requirements for civil aviation applications. However, all these SBAS will operate on the same GPS L1 frequency and will ultimately depend on the availability of basic GPS SPS. Hence SBAS does little or nothing to address the robustness concerns of GPS.

[0007] The electron density of the ionosphere varies as a function of geographic location. In a vectorized, wide area differential solution such as that employed by an SBAS, a large number of sampling locations are needed to compute an accurate model of the variation of the time delay induced in a signal traveling through various locations in the ionosphere. Therefore, in order to get adequate sampling of the state of the ionosphere, the SBASs employ a number of reference stations over a wide region that are fixed to the earth. These reference stations are connected via a ground based telecommunications network to a central processing facility. Each reference station observes the transmitted SPS signals from the GPS satellites visible at the reference station, performs some signal integrity monitoring, and passes the data on to the central processing facility via the ground based telecommunications network. These stations also track a component of the PPS using a codeless tracking technique in order to make dual frequency measurements of the ionosphere. The central processing facility uses the data from the reference stations to compute "wide-area" differential corrections where separate corrections are given for various satellite pseudo range error components. The SBASs then provide estimates of the vertical ionospheric delay at predefined grid points over the region covered by the SBAS to users of the SBAS. The estimates are broadcast from the SBAS to the user via a satellite link which is designed to be very similar to a GPS signal. The GPS receiver can then compute an estimate of the ionospheric delay for each pseudo range based on the user's location and the geometry of the satellites and compute its position more accurately by accounting for the ionospheric delay in the SPS signals and by applying the other differential correction components included in the SBAS signal.

[0008] The SBAS architecture is attractive in that it supports operations over a wide area and may even be capable of providing a level of service sufficient to support category 1 precision approach aircraft operations. However, the complexity and cost of such a system makes it impractical for most States or regions to consider employing such a system. Particularly, the cost of the ground based telecommunica-

tions network can be very significant. Also, in order to get good sampling of the ionosphere and a more accurate grid of the errors introduced by the ionosphere, a large number of reference stations are required, which in turn increases the cost of connecting all the reference stations with the ground based telecommunication networks.

[0009] Therefore, it is desirable to develop a system and method for accurately measuring and correcting the time delay induced in signals traveling through the ionosphere. Additionally, it is desirable to perform the ionospheric delay sampling without the need for an extensive network of ground based monitoring stations. It is also desirable to provide monitoring stations without the need for the monitoring stations to be connected to the central processing facility by expensive ground based telecommunication networks.

SUMMARY OF THE INVENTION

[0010] The present invention is directed to a method and apparatus for providing a global communication, navigation and surveillance (GCNS) system that overcomes the shortcomings of the GPS without the need for an extensive SBAS. Additionally, the present invention provides for an entirely new class of capabilities heretofore unavailable with either the GPS or SBAS.

[0011] In one preferred embodiment, the GCNS system of the present invention makes use of a plurality of time synchronized satellites. Each satellite broadcasts multiple navigation signals, can engage in two-way communications, and can receive and relay surveillance signals. Each satellite of the plurality of satellites is part of a network that allows each satellite of the plurality of satellites to communicate with any other satellite of the plurality of satellites. There is a terrestrial segment that has a processing apparatus that is capable of two way communication with any satellite of the plurality of satellites through the network. There is also at least one mobile user device that is capable of two-way communication with the plurality of satellites. The at least one user device can directly communicate with each satellite of the plurality of satellites that are within a line of sight of the user device and with the remaining satellites through the network. The at least one user device is also capable of receiving the navigation signals broadcast by the plurality of satellites and computing a position of the at least one user device based on the received navigation signals. The at least one user device can broadcast a surveillance signal to the plurality of satellites so that the position of the at least one user device can be computed by the processing apparatus.

[0012] Preferably, the surveillance signal broadcast by the at least one user device is a dual frequency surveillance signal which the processing apparatus uses to compute correction factors for ionospheric induced time delays in signals traveling through the ionosphere between the at least one user device and each satellite of the plurality of satellites that received the surveillance signal. The processing apparatus using the correction factors and the surveillance signals can compute a more accurate position of the user device. Preferably, the correction factors are transmitted to the at least one user device so that the at least one user device can use the correction factors along with navigation signals to compute a more accurate position of the at least one user device. The GCNS system thereby provides surveillance

capabilities for the plurality of satellites that correct for ionospheric delay and also provides the at least one user device with correction factors so that a more accurate position of the at least one user device can be computed by the at least one user device.

[0013] Preferably, each satellite of the plurality of satellites has communication switching capabilities so that each satellite of the plurality of satellites can route communication signals to a desired recipient. The network can be formed by having each satellite of the plurality of satellites directly communicating with at least two other satellites of the plurality of satellites, with at least two ground stations, or with at least one other satellite of the plurality of satellites and at least one ground station so that redundant communication paths exist and each satellite of the plurality of satellites is capable of communicating with any other satellite of the plurality of satellites either directly or through the network.

[0014] Preferably, the at least one user device is one of a plurality of user devices with each user device of the plurality of user devices providing dual frequency surveillance signals to the plurality of satellites. The processing apparatus is capable of using the dual frequency surveillance signals to compute a model which describes variation of an ionospheric induced time delay in signals traveling through the ionosphere as a function of geographic location. Correction factors for the ionospheric induced time delay in signals passing through the ionosphere are computed for each line of sight between the plurality of user devices and the plurality of satellites that receive the surveillance signals. The model along with the correction factors are broadcast by the plurality of satellites so that a device capable of receiving and processing these broadcasts can use the navigation signals along with the model and correction factors to compute a more accurate position of the device. The GCNS system thereby provides a map of the ionosphere along with correction factors to allow for increased accuracy in the determination of the position of one of the user devices without the need for extensive use of ground based monitoring stations. Because the ionospheric delay scales linearly with frequency, the ionospheric delay model broadcast by the system can be used to correct for ionospheric delay on any frequency used by the system. Consequently, improved accuracy can be achieved for single frequency navigation or surveillance users.

[0015] The GCNS system also provides the ability to verify the accuracy of the position determined by a user device. The user device can broadcast its computed position (based on received navigation signals) along with the surveillance signals. The processing apparatus can use the surveillance signal broadcast by a user device to compute a position of the user device. The location of the user device based on the surveillance signals can be compared to the reported position of the user device to determine the difference between the two computed positions. This comparison provides a degree of integrity checking to the system. If the positions differ by more than a predetermined amount an error is probably occurring somewhere in the system and the processing apparatus can perform a system integrity check of the plurality of satellites to verify that each satellite is broadcasting correct navigation signals. Additionally, the GCNS system can notify the user device of the difference

between the two computed positions and whether the system integrity has been verified so that the user can have a correct position of the user device.

[0016] Monitoring stations can be provided that are fixed on the earth at known positions and are capable of receiving the navigation signal and of two-way communication with the plurality of satellites. The monitoring stations can operate similarly to the user devices. The monitoring stations can monitor the navigation signals and compute the indicated position of the monitoring station based on the navigation signals so that the integrity of the system can be checked. The monitoring stations can also broadcast dual frequency surveillance signals to the satellites so that the delay in signals travelling through the ionosphere between the monitoring stations and the satellites that receive the surveillance signals can be measured and corrected for. In this way, adequate sampling of the ionosphere can be achieved even in geographic regions where user densities are too low to otherwise provide a large enough number of ionospheric delay observations.

[0017] Additional capabilities are also realized with the GCNS system. When a user device is not able to receive the navigation signals being broadcast by the plurality of satellites the user device can communicate to the GCNS system that it is not receiving the navigation signals. The processing apparatus can then perform a system integrity check to ensure that the plurality of satellites are properly broadcasting the navigation signals. If the plurality of satellites are found to be operating correctly, then either the user device is malfunctioning or there is an interference source that is interfering with the reception of the navigation signals by the user device. When there are a plurality of user devices within a region that report not receiving navigation signals and the satellites are found to be operating correctly, the processing apparatus can use the positions of the plurality of user devices (computed based upon surveillance signals sent by the user devices) to determine the probable location of an interference source that is preventing the reception of the navigation signals. The GCNS system can then report the problem and the probable location of the interference source to a desired recipient such as a state's frequency management authority. In this manner, the operation of the GCNS system can be continually monitored and probable locations of interference sources can be determined.

[0018] The GCNS system provides a robust navigation capability because the tightly coupled communications, navigation and surveillance capabilities allow the surveillance and navigation capabilities to act as a backup for each other. For example, if one of the plurality of user devices is unable to receive the navigation signals broadcast by the plurality of satellites, the system can use the surveillance function to obtain a position fix for the user and provide the position fix to the user over the communications link. A backup navigation mode is realized in this manner. Similarly, if the system is unable to perform the surveillance function for a particular user device, then the user device may broadcast its position as determined from the navigation signals broadcast from the satellites. A backup surveillance mode is realized in this manner.

[0019] Another benefit realized by the GCNS system is that the processing apparatus is capable of computing the ephemeris of each satellite of the plurality of satellites based

upon signals broadcast by each satellite of the plurality of satellites. Preferably, the processing apparatus uses the computed ephemeris of each satellite of the plurality of satellites to compare it with the navigation signals being broadcast by each satellite of the plurality of satellites to ensure that the plurality of satellites are broadcasting correct navigation signals. Because the satellites communicate with each other, the processing apparatus can correct the navigation signals being broadcast by each satellite of the plurality of satellites found to be in error. The GCNS system can thereby autonomously monitor and correct itself when incorrect navigation signals are being broadcast by one of the satellites.

[0020] Further areas of applicability of the present invention will become apparent from the detailed description provided hereinafter. It should be understood that the detailed description and specific examples, while indicating the preferred embodiment of the invention, are intended for purposes of illustration only and are not intended to limit the scope of the invention.

BRIEF DESCRIPTION OF THE DRAWINGS

[0021] The present invention will become more fully understood from the detailed description and the accompanying drawings, wherein:

[0022] **FIG. 1** is a simplified overview of the GCNS system of the present invention;

[0023] **FIG. 2** is a diagram of the GCNS system of **FIG. 1** showing the navigation signals travelling through the ionosphere to a user device;

[0024] **FIG. 3** is a diagram of the GCNS system of **FIG. 1** showing a user device communicating with the satellites of the GCNS system via the ICS signals with the ICS signals travelling through the ionosphere;

[0025] **FIG. 4** is a diagram of the GCNS system of **FIG. 3** with two user devices communicating with the satellites via ICS signals traveling through the ionosphere; and

[0026] **FIG. 5** is a drawing of the GCNS system showing the ability for peer to peer communication.

DETAILED DESCRIPTION OF THE PREFERRED EMBODIMENTS

[0027] The following description of the preferred embodiment(s) is merely exemplary in nature and is in no way intended to limit the invention, its application, or uses.

[0028] Referring to **FIG. 1**, there is shown a GCNS system **20** in accordance with a preferred embodiment of the present invention. The GCNS system **20** provides communications, navigation and surveillance capabilities to and from a mobile user device **22**, a monitoring station **24**, a master control station (MCS) **26**, a satellite network access gateway (SNAG) **28** and/or a plurality of satellites **30**. The MCS and SNAG are also referred to as ground stations.

[0029] The GCNS system **20** generally comprises a space segment **31**, a terrestrial segment **32**, and a user segment **34**. The space segment **31** may include any number of satellites **30** needed to provide coverage for any given region of the earth **38** where mobile user devices **22** are expected to be used. Preferably, there are enough satellites **30** so that a user device **22** is within a line of site of at least three satellites **30**

and even more preferably is within a line of site of at least four satellites **30**. The satellites **30** are time synchronized. As is well known in the art and as will be explained below, if the user device **22** has a line of sight to three satellites **30** a position of the user device **22** can be determined based upon signals sent between the satellites **30** and the user device **22**.

[0030] In order to provide adequate coverage for the entire earth **38**, the GCNS system **20** will preferably use between **18** to **30** satellites **30**. Preferably, the satellites **30** are high powered medium earth orbit satellites. However, geosynchronous satellites may also be integrated into the GCNS system **20**. Each satellite **30** is preferably a state-of-the-art digital processing satellite that is programmable on orbit. Because the satellites **30** are programmable on orbit, modifications to services or entirely new services can be introduced as the system evolves without the need to wait for the satellites **30** to be refreshed. The programmable on orbit capability allows the GCNS system **20** to evolve to meet the needs of the civil community.

[0031] Each satellite **30** of the space segment **31** carries a Navigation and Timing (NT) payload (not shown) as well as an Integrated Communications/Surveillance (ICS) payload (not shown). The satellites **30** also include a very large aperture antennae (approximately 20 to 50 feet in diameter) (not shown) to support the ICS capabilities of the satellites **30**. Preferably, at least one of the satellites **30** is capable of measuring the Time of Arrival (TOA) or Time Difference of Arrival (TDOA) of surveillance signals received by the satellites **30**, as will be explained in more detail below. Even more preferably, each satellite **30** is capable of measuring the TOA or TDOA of surveillance signals received by the satellites **30**.

[0032] Each satellite **30** is part of a network that allows each satellite **30** to communicate with any other satellite **30** of the plurality of satellites **30** in the GCNS system **20**. Preferably, the network is formed by having each satellite **30** connected to at least two other satellites **30** via wide band cross links **40**. However, it should be understood that while it is preferred to use cross links **40**, other satellite constellation architectures that do not employ cross links **40** are possible and are within the scope of the invention as defined by the claims. The cross links **40** allow the satellites **30** to transfer data to/from other satellites **30**. The cross links **40** have a high data transfer capacity sufficient to support the communications and surveillance functions of the GCNS system **20**. The cross links **40** connect all of the satellites **30** to form a network with redundant paths so that information can be moved from any satellite **30** to any other satellite **30** in the space segment **31** via the cross links **40**. The cross links **40** are monitored by the satellites **30** and may be used to develop a range measurement between satellites **30**. If a satellite **30** fails or is removed from the network, the network is reconfigured by establishing new cross links **40** that bypass the removed satellite **30** so that the network continues to operate. In the same manner, a new or repaired satellite **30** can be introduced into the network. The ICS payload allows each satellite **30** of the space segment **31** to operate as a communication switch to route communications signals to a desired recipient. The linked space segment **31** thereby forms a robust communications backbone through which the full capabilities of the GCNS system **20** can be realized.

[0033] The network can also be formed by having each satellite **30** directly communicating with at least one other satellite **30** and at least one ground station or by having each satellite **30** directly communicating with at least two ground stations. The network thereby provides redundant communication paths so that information can be moved from any satellite **30** to any other satellite **30** in the space segment **31** via the network. The communication between the satellites **30** and the ground stations will be discussed in more detail below.

[0034] Preferably, the GCNS system **20** operates on nine frequencies. The navigation services provided by the GCNS system **20** build on the services currently provided by GPS. The GCNS system **20** provides ranging or navigation signals **44** on three different frequencies. Preferably, all three navigation signals **44** are in frequency bands allocated by the ITU for Aeronautical Radionavigation Services (ARNS) as well as for Radio Determination Satellite Services (RDSS). The first navigation signal **45**, is preferably broadcast at 1575.42 megahertz and is equivalent to the L1 C/A signal used by the GPS today. In addition, the first navigation signal **45** preferably includes a new set of codes with improved cross correlation properties and is broadcast in quadrature with the C/A code signal. The second navigation signal **46**, is preferably broadcast at 1176 megahertz and is equivalent to the L5 signal as defined in RTCA DO-261. The third navigation signal **47**, is similar in structure to the second navigation signal **46**. The frequency at which the third navigation signal **47** is to be broadcast has yet to be determined. The third navigation signal **47** is designed to support three frequency carrier ambiguity resolution positioning for the user segment **34**.

[0035] The integrated communications/surveillance capabilities of the satellites **30** are performed via the ICS signals **50**. The ICS signals **50** comprise three signals, C1, C2, and C3 which are indicated as **52**, **54**, and **56**. The ICS signals **50** are preferably one to five megachip spread spectrum signals similar to those defined in CDMA-2000. The C1 signal **52** provides communication from the satellites **30** to the user segment **34** and/or the monitoring stations **24**. The C2 signal **54** provides communications/surveillance from the user segment **34** and/or the monitoring stations **24** to the satellites **30**. The C3 signal **56** is a second communications/surveillance signal from the user segment **34** and/or the monitoring stations **24** to the satellites **30**. The C3 signal **56** preferably is at a frequency several hundred MHz above or below the frequency of the C2 signal **54**. In a preferred embodiment, the third navigation signal **47** is placed in the same band as the C1 signal **52** so that the third navigation signal **47** may also act as a pilot tone for initial acquisition and synchronization of the user equipment within the GCNS system **20**.

[0036] The terrestrial segment **32** communicates with the space segment **31** via feeder link signals **57**. However, some components of the terrestrial segment **32**, such as the monitoring stations **24**, may communicate with the space segment **31** via the ICS signals **50**. The feeder link signals **57** are comprised of two signals, FL1 and FL2 **58**, **60**. The FL1 signal **58** is the feeder link between the terrestrial segment **32** and the space segment **31**. The FL2 signal **60** is the feeder link from the space segment **31** to the terrestrial segment **32**.

Both the FL1 and FL2 signals **58**, **60** are preferably at a frequency band typically used for such feeder links **57**, such as the Ka or Ku band.

[0037] While the above description of some of the various signals used in the GCNS system **20** have been described with references to specific frequencies and other properties, it is to be understood that these descriptions are provided for exemplary purposes and are not to be construed as limiting the scope of the invention as defined by the claims. Additionally, the frequencies and properties of the various signals may change to increase the performance of the GCNS system **20** or to meet regulatory requirements of various government agencies that control the frequencies on which the GCNS system **20** can operate.

[0038] The user segment **34** is comprised of at least one mobile user device **22** and preferably a plurality of mobile user devices **22**. The GCNS system **20** is designed to support simple, inexpensive, integrated mobile user devices **22**. Because the user devices **22** are mobile, the GCNS system **20** is designed to support small, lightweight equipment with low power consumption requirements. However, it is to be understood that the user devices **22** will come in packages that range from small hand held units to rack mounted base station transceiver units with expanding capabilities. The mobile user device **22** could comprise aircraft, cruise ships, or any other moving vehicle. Thus, the illustration of the mobile user device **22** as aircraft in the FIGS. herein should not be construed as limiting the applicability of the system **20** to only aircraft. The GCNS system **20** is designed to work with all these various types of user devices **22**. Additionally, while the user devices **22** are discussed as being mobile, it is not necessary for the user devices **22** to be mobile to operate with the GCNS system **20**. The user devices **22** connect to the satellites **30** via the three ICS signals **50** and the three navigation signals **44**.

[0039] The terrestrial segment **32** comprises the MCS **26** and, preferably, one or more backup MCSs (not shown). The terrestrial segment **32** may also comprise the SNAG **28** and any number of monitoring stations **24**. The MCS **26** and the SNAG **28** facilities are connected to one or more satellites **30** of the space segment **31** via the feeder link signals **57** and/or the three ICS signals **50**. The monitoring stations **24** are preferably connected to the satellites **30** via the three ICS signals **50** and the three navigation signals **44**. A processing apparatus (not shown), such as a computer or the like, is also included in the terrestrial segment **32**. As is known in the art, the processing apparatus monitors the GCNS system **20** and performs positioning calculations for user devices **22**, satellites **30** and any other device connected to the GCNS system **20**. The processing apparatus can also control the communications functions of the space segment **31**. The processing apparatus can be located in the MCS **26** or can be in a different ground station. It is also possible to have the processing apparatus located in one of the satellites **30** of the space segment **31**.

[0040] The MCS **26** is preferably the primary control segment for the GCNS system **20**. The MCS **26** is responsible for the Telemetry and Control (T&C) communications with the satellites **30**. T&C instructions for the space segment **31** are delivered to all the satellites **30** via the FL1 signal **58**, the network, and the cross links **40**, as required, so that T&C commands can be delivered to or issued from

any satellite **30** at any time. Preferably, the MCS **26** is capable of directly communicating with a minimum of three satellites **30** at all times via the feeder link signals **57**. The network, the cross links **40**, and the ability of the MCS **26** to communicate simultaneously with a minimum of three satellites **30** via the backhaul signals **57** results in redundant, full time monitoring and control of the space segment **31**. The MCS **26** may also operate as a Network Operation Center (NOC)(not shown). The NOC controls the operations of the communications capabilities of the GCNS system **20**. The NOC may also be separate from the MCS **26**. Preferably, the processing apparatus is part of the NOC.

[0041] The SNAG **28** provides a connection between the communications capabilities of the GCNS system **20** and the terrestrial communications network (not shown) in various regions around the world. The SNAG facilities **28** could be operated by regional service providers or service resellers of the communication and surveillance capabilities of the GCNS system **20**. The SNAG facilities **28** access one or more satellites **30** using the feeder link signals **57**. Because the SNAG facilities **28** can be operated by regional service providers or service resellers, the SNAG facilities **28** do not have T&C capabilities.

[0042] The monitoring stations **24** are similar to the user devices **22**. The monitoring stations **24** have navigation receivers (not shown) capable of receiving the navigation signals **44** and of receiving and sending the ICS signals **50**. The monitoring stations **24** communicate with the MCS **26** or other appropriate devices within the system (not shown) by communicating with the space segment **31** via the ICS signals **50** and the space segment **31** in turn communicates with the MCS **26** or other appropriate devices (not shown) via the feeder link signals **57**. The monitoring stations **24** check various aspects of the navigation signals **44** and the ICS signals **50** and sends an alarm via the ICS signals **50** if a problem is found. Otherwise, the monitoring stations **24** report nominal status with a short burst of data on two frequencies, such as the C2 and C3 signals **54**, **56** that can be used by the GCNS system **20** to measure ionospheric delay, as will be discussed below. The short data bursts also protect the monitoring stations **24** from exposure to latent failures. The monitoring stations **24** can check the navigation signals **44** continuously, at scheduled intervals, and/or as requested or polled by the GCNS system **20**.

[0043] The GCNS system's **20** communication services are based on spread spectrum communications. The wave forms and signaling protocols are designed to support basic data and voice communications. FIG. 5 illustrates a typical peer to peer communications connection between user devices **22**. In this example, one user device is on an aircraft flying through the air and the other user device is in a stationary building perhaps halfway around the world. The primary link between either user device **22** and a satellite **30** is through a single spot beam **62** on a single satellite **30**. The communications switching capabilities of the satellites **30** are used to connect the two user devices **22**. The user device **22** could also be connected to a monitoring station **24**, the MCS **26**, or a SNAG **28** by using the communications switching capabilities of the satellites **30**. If the monitoring station **24**, the MCS **26**, a SNAG **28**, or other user device **22** is connected to another satellite **30**, as is shown in FIG. 5, one or more cross links **40** and one or more satellites **30** may be required to be used to facilitate the connection. Thus, the

GCNS system 20 supports user to user or peer to peer communication along with communication between all of the components of the GCNS system 20.

[0044] Referring now to FIG. 2, the navigational capabilities of the GCNS system 20 are shown. The satellites 30 broadcast navigation signals 44 from each satellite 30 of the space segment 31. The navigation signals 44 contain information related to the position of the satellite 30 from whence the signal originated along with the time at which the signal was sent. Preferably, each satellite 30 of the space segment 31 have multiple atomic clocks and a very accurate system time is transferred to each satellite 30 of the space segment 31 through the network or cross links 40 so that all the satellites 30 are time synchronized and the GCNS system 20 can provide useful navigational services. The synchronizing of the time on each satellite 30 is performed by methods well known in the art. Preferably, the navigation signals 44 broadcast by each satellite 30 of the space segment 31 are three signals broadcast on three different frequencies, as was discussed above. A user device 22 receiving the navigation signals 44 broadcast by the satellites 30 can compute its position based upon the received navigation signals 44, as will be discussed in more detail below.

[0045] The GCNS system 20 also includes a surveillance capability. The surveillance capability and the navigation capabilities operate along the same principles. As shown in FIG. 3, the user device 22 can broadcast omni directional surveillance signals 64 to the space segment 31 via the C2 and C3 signals 54, 56. Preferably, the surveillance signals 64 sent by the user device 22 include a special coded sequence designed for rapid acquisition and precise determination of the time of arrival (TOA) of the surveillance signals 64. This coded sequence is used to independently measure the position of the user device 22 when it is using the communication capabilities of the GCNS system 20. To use this capability, the user device 22, after being turned on, logs in to the GCNS system 20. The user device 22 negotiates a surveillance reporting interval with the GCNS system 20. Then at the prescribed time, the user device 22 broadcasts omni directionally the coded sequence within the surveillance signals 64. The satellites 30 search for the coded sequence based on the last known or current projected position of the user device 22. The surveillance signals 64 are then received by three or more satellites 30 and, preferably, by four or more satellites 30 in order to achieve the best accuracy. Each satellite 30 then correlates the received surveillance signals 64 with a local replica of the expected coded sequence in order to establish the TOA of the coded sequence within the surveillance signal 64. The surveillance signals 64 may also include a sequence that corresponds to other measurements performed by the user device 22 or provided to the user device 22 from another source. For example, when the user device 22 is on an aircraft the surveillance signals 64 may include a sequence that informs the GCNS system 20 of the barometric altitude of the user device 22 at the time of the broadcasting of the surveillance signals 64. The fusion of sensor readings into the surveillance signals 64 to aid in the position solution is known to those skilled in the art.

[0046] After reception, the TOA, the user ID and any other data attached to the surveillance signals 64 are forwarded via the cross links 40, FL1 signal 58, and/or C1 signal 52 to the processing apparatus. The processing apparatus receives

multiple TOA information from each satellite 30 that received the surveillance signals 64 from the user device 22. The TOA along with the time of transmission from the user device 22 give a time interval which can be considered to be a pseudo range measurement from the satellite 30 to the user device 22. Preferably, the measure of the time interval is performed on one or more of the satellites 30 in the space segment 31 and then communicated to the processing apparatus so that the processing apparatus is provided with the time interval to be used as a pseudo range measurement from the satellite 30 to the user device 22. Given the precise knowledge of the locations of the satellites 30 that is available throughout the GCNS system 20, the pseudo ranges can be used to solve for the user device's 22 position. Each pseudo range defines the radius of a sphere about the known position of the satellite 30 that received the surveillance signals 64. The user device 22 must be positioned on the surface of that sphere. Multiple pseudo ranges define multiple spheres and the position of the user device 22 must be somewhere on the intersection of the spheres. Thus the GCNS system 20 is capable of determining the position of a user device 22 based on the surveillance signals sent by the user device 22. This type of position solution is well known from current GPS applications and can also be used by the user device 22 to compute the position of the user device 22 when receiving the navigation signals 44 from the GCNS system 20.

[0047] Alternatively, Time Difference of Arrival (TDOA) techniques may be used to determine the position of the user device 22 based on surveillance signals 64 sent by the user device 22. For each set of TOAs, the GCNS system 20 can compute $N!/(2!(N-2)!)$ time differences of arrival. Preferably, the TOAs are computed by one or more satellites 30 in the space segment 31 and then communicated to the processing apparatus which in turn computes the TDOAs for various satellite pairs. Each TDOA defines a surface (which happens to be a hyperbola) upon which the user device 22 must be in order for the two observers (the two satellites 30 that provided the set of TOAs) to see the associated TDOA. Multiple TDOAs define multiple hyperbolas upon which the user device 22 must be located. Therefore, the user device 22 must be positioned at the intersection of the multiple hyperbolas.

[0048] In use, the surveillance capabilities of the GCNS system 20, as shown in FIGS. 3 and 4, can be used to monitor the time delay induced in signals traveling through the ionosphere 66 which is located between the space segment 31 and the terrestrial segment 32 and/or the user segment 34. Preferably, the surveillance signals 64 broadcast by the user device 22 are two signals on two different frequencies, such as the C2 signal 54 and the C3 signal 56. Even more preferably, the C2 and C3 signals 54, 56 are phase coherent and chip synchronous at the phase center of a transmit antenna (not shown) (to the extent possible) on the user device 22. The ionosphere 66 will induce different time delays in the two surveillance signals 64. The relative difference between the two arrival times of the surveillance signals 64 on the two different frequencies can be used to measure the ionospheric delay induced in signals traveling through the ionosphere 66, as is known to those skilled in the art. In this way, the GCNS system 20 directly collects information about the ionosphere 66 from any user device 22 that broadcasts surveillance signals 64 on two different frequencies.

[0049] The satellites 30 that receive the surveillance signals 64 transmitted on two different frequencies provide the time of arrival information for both the C2 signal 54 and the C3 signal 56 to the processing apparatus. The processing apparatus will then compute the delay induced by the ionosphere 66 in signals traveling through the ionosphere 66. Alternatively, the difference in the TOAs of the two frequencies may be computed on the satellite 30 and the result sent to the processing apparatus. Because the surveillance signals 64 are received by multiple satellites 30 the surveillance signals 64 travel through different portions of the ionosphere 66. The locations at which the surveillance signals 64 (or any signals) travel through the ionosphere 66 are called pierce points. The processing apparatus collects slant range ionospheric delay measurements for pierce points where the line of sight from the user device 22 to the satellites 30 passes through the ionosphere 66. Because the electron density of the ionosphere 66 varies throughout the ionosphere 66, the delay induced by the ionosphere 66 in signals travelling through the ionosphere 66 may be different for each pierce point or specific line of sight between the user device 22 and the satellites 30. Therefore, the processing apparatus will measure the slant range ionospheric delay for each pierce point based upon the path the surveillance signals 64 travel to reach the various satellites 30. As is known in the art, an international standard has been created that divides the ionosphere 66 into a sampling grid of known coordinates. The ionospheric delay for each pierce point can be used with the grid to develop a model of the measured ionospheric delay for the various grid locations for which measurements are available. When the number of user devices 22 is large, the GCNS system 20 will be collecting ionospheric delay measurements for a very large number of pierce points and may allow the development of new grid coordinates that are more compact due to the large number user devices 22 that provide signals that can be used to measure ionospheric delay. Therefore, the GCNS system 20 may allow for a denser grid to be created for the ionosphere 66 and result in a more precise model of time delays caused by the ionosphere 66.

[0050] The slant range ionospheric delay measurements can be used to determine a nominal vertical delay at any arbitrary point by interpolating the pierce point measurements after correction by an obliquity factor as is well known in the art. The nominal vertical delay model of the ionosphere 66 developed from the ionospheric delay measurements then becomes a resource that the GCNS system 20 can use to compute the expected delay for any arbitrary line of sight through the ionosphere 66 covered by the sampling grid. Because the time delay scales directly with frequency, ionospheric delay data measured via the surveillance signals 64 may be used to develop corrections for the delay experienced by the navigation signals 44 on their respective frequencies. Similarly, the delay model may also be used to determine the ionospheric delay for a single frequency surveillance user.

[0051] As can be seen in FIG. 3, when the surveillance signals 64 travel from a single user device 22 to three different satellites 30 the user device 22 has three different lines of sight 70, 72, 74 to the three different satellites 30 and the ionosphere is pierced in three different places based on the three different lines of sight 70, 72, 74 the surveillance signals 64 follow to reach the satellites 30. The processing apparatus measures the time delay induced in the surveil-

lance signals 64 on each of the three lines of sight 70, 72, 74. For example, the processing apparatus will measure the time delay in the surveillance signals 64 caused by the surveillance signals 64 traveling along line of sight 70 of the ionosphere 66. The processing apparatus will do the same for the lines of sight 72, 74.

[0052] The number of pierce points by which the ionosphere 66 is sampled is dependent upon the number of user devices 22 broadcasting surveillance signals 64 and the number of satellites 30 that receive the surveillance signals 64. As can be seen in FIG. 4, when two user devices 22 are broadcasting surveillance signals 64, the ionosphere 66 might be sampled by six pierce points that correspond to the six lines of sight 70, 72, 74, 76, 78, 80 between the two user devices 22 and the three satellites 30 that receive the surveillance signals 64. In this manner, the GCNS system 20 uses the user devices 22 to monitor the state of the ionosphere 66 and correct for ionospheric induced time delays in the surveillance signals 46.

[0053] Preferably, the processing apparatus broadcasts the vertical delay model as sampled at an appropriately spaced grid of coordinates. The coordinates of the grid are known to the user devices and adhere to a simple numbering system. The coordinate numbers and the correction factors can be included in the navigation signals 44 or sent via the ICS signals 50. Preferably, the user device 22 can receive the correction information along with the coordinate numbers and compute corrections for the ionospheric induced time delays in signals from the GCNS system 20 received by the user device 22 that travel along the line of sight specific to the user device's 22 location. This will allow the user device 22 to calculate a more accurate position of the user device 22.

[0054] The GCNS system 20 also makes it possible for the user device 22 to measure the ionospheric delay caused in navigation signals 44 travelling from the satellites 30 through the ionosphere 66 and to the user device 22. Like the surveillance signals 64, the satellites 30 can broadcast navigation signals 44 on two different frequencies, such as the first navigation signal 45 and the second navigation signal 46. Preferably, the satellites 30 can broadcast navigation signals 44 on three different frequencies, as discussed above. When using the user device 22 to measure the ionospheric induced time delays, it is preferred that the first and second navigation signals 45, 46 be phase coherent and chip synchronous at the phase center of a satellite transmit antenna (not shown) (to the extent possible) so that the relative difference between the two arrival times of the first and second navigation signals 45, 46 can be used to measure the ionospheric induced time delay. The user device 22 can then correct for the ionospheric delay in the received navigation signals 44 and calculate a more accurate position of the user device 22.

[0055] The user device 22 can also communicate the results of measuring the ionospheric induced time delay to the space segment 31 so that the space segment 31 can use the measurements to correct for ionospheric induced time delays in signals received by the space segment 31 and/or share the correction information with other users of the GCNS system 20. In this way, the GCNS system 20 directly collects information about the ionosphere from any suitably equipped user device 22. Because the user devices 22 are

mobile, the portion of the ionosphere 66 being measured at any given time by a single user device 22 can vary and measures of the ionosphere 66 can be made from locations where terrestrial based monitoring stations 24 are impractical, such as over the water. Furthermore, because the line of sight for the ionospheric delay observations is relatively insensitive to the position uncertainty of the user device 22, ionospheric data can be obtained from non-stationary platforms such as buoys etc. In this way, the monitoring network can be extended into regions simply not possible for an SBAS which relies on terrestrial communications capabilities.

[0056] Because the GCNS system 20 can directly measure the ionosphere 66 from signals broadcast by user devices 22 and can collect ionospheric measurements made by user devices 22 the need for ground based monitoring stations 24 is reduced and can possibly be eliminated in some areas. However, if not enough user devices 22 are actively using the GCNS system 20, monitoring stations 24 can be utilized to fill in any gaps in information about the ionosphere 66. Therefore, the GCNS system 20 is preferably designed so that the monitoring stations 24 can also be used to measure the ionospheric induced time delay in signals traveling through the ionosphere 66. The monitoring stations 24 can be equipped similar to the user devices 22 in that the monitoring stations 24 would be capable of sending surveillance signals 64 on two different frequencies and also capable of receiving dual frequency navigation signals 44 from the satellites 30. The monitoring stations 24 can then function just as the above described user devices 22 function. Because the monitoring stations 24 communicate with the space segment 31 via the ICS signals 50, the need for a terrestrial based communication network to connect the monitoring stations 24 to the processing apparatus is eliminated.

[0057] The GCNS system 20 can be used to confirm the position of a user device 22 calculated by the user device 22. As was described above, the user device 22 can calculate its position based on navigation signals 44 received by the user device 22. The user device 22 can then communicate its calculated position to the space segment 31 via the C2 signal 54 and/or the C3 signal 56. The user device 22 can also transmit surveillance signals 64 to the space segment 31 so that the processing apparatus can independently compute a position of the user device 22. The processing apparatus can compare the position computed by the user device 22 with the position computed by the processing apparatus. If the two calculated positions differ by more than a predetermined amount there may be an error in the GCNS system 20.

[0058] When the two calculated positions differ by more than the predetermined amount, the processing apparatus can check the integrity of the space segment 31 to see if an error is occurring in the space segment 31. The processing apparatus can request, via the cross links 40 or the network, the navigation signals 44 being broadcast by each satellite 30 and compare the navigation signals 44 of each satellite 30 with the ephemeris of the satellites 30 to ensure that each satellite 30 is broadcasting a correct navigation signal 44. If an error in the navigation signals 44 being broadcast by any of the satellites 30 is found, the space segment 31 can be reconfigured to exclude the satellite 30 that is experiencing the error in its navigation signals 44. When the error is corrected, the space segment 31 can again be reconfigured to

include the repaired satellite 30 in the space segment 31. The processing apparatus can report the error to the master control station 26 via the FL2 signal 60. Additionally, the space segment 31 can transmit to the user device 22 via the C1 signal 52 a message indicating that an error is occurring in the space segment 31. The user device 22 will then know to disregard the affected satellite 30 and compute the position of the user device 22 based only on healthy satellites 30. In this manner, the GCNS system 20 is self monitoring and can autonomously detect and correct errors occurring in the GCNS system 20 and the user device 22 can obtain its correct position.

[0059] If the two calculated positions differ by more than the predetermined amount and an error in the space segment 31 is not found, the space segment 31 can transmit to the user device 22 via the C1 signal 52 the position of the user device 22 calculated by the space segment 31 and a message indicating that no error in the space segment 31 has been found. A user of the user device 22 is then aware that the user device 22 may be malfunctioning and should be checked while also being provided with a correct position of the user device 22. In this manner, the GCNS system 20 enables a user with a malfunctioning user device 22 to continue to use the user device 22 to monitor the position of the user device 22.

[0060] The GCNS system 20 can also monitor the ephemeris of the space segment 31. The relative ephemeris of the space segment 31 can be determined and monitored by the space segment 31. Preferably, each satellite 30 is connected via cross links 40 to three other satellites 30 and even more preferably to four or more satellites 30. The satellites 30 can transmit their navigation signals 44 to the other satellites 30 via the cross links 40 and the processing apparatus can then compute the position of any satellite 30 relative to any other satellite 30 of the space segment 31 based on the navigation signals 44 and satellite 30 to satellite 30 range measurements made via the cross links 40. In this scenario, the navigation signals 44 are treated as surveillance signals 64 and are used to determine the position of the transmitting satellite's 30 position relative to the position of the receiving satellites' 30 positions. The relative positions are determined based on the TOA and/or TDOA techniques discussed above. Additionally, the ephemeris of the satellites 30 relative to the earth can also be determined by the GCNS system 20. When three and preferably four terrestrial segment 32 components, such as a monitoring station 24, the MCS 26, and/or a SNAG 28 receive navigation signals 44 broadcast from the same satellite 30, that satellite's 30 position relative to the earth can be calculated by treating the broadcast navigation signals 44 as surveillance signals 64 and by using the TOA and/or TDOA techniques discussed above. The ephemeris of the remaining satellites 30 of the space segment 31 can then be determined relative to the satellite 30 whose ephemeris was determined relative to the earth. Because the cross links 40 do not travel through distorting mediums, such as the ionosphere, when travelling between the satellites 30, the positions of the satellites 30 relative to each other can be more accurately and easily determined. In this manner, the GCNS system 20 is capable of precise monitoring of the ephemeris of the space segment 31.

[0061] Another capability of the GCNS system 20 is the ability to detect and locate an interference source (not shown) that is interfering with one of the signals used by the

GCNS system 20. For example, when a user device 22 is not receiving one of the navigation signals 44 being broadcast by the satellites 30, the user device 24 can communicate to the space segment 31 via the C2 signal 54 or C3 signal 56 that it is not receiving one of the navigation signals 44. The processing apparatus can then check the integrity of the space segment 31 and verify that each satellite 30 is broadcasting navigation signals 44. If all the satellites 30 are found to be broadcasting navigation signals 44, either the user device 22 is malfunctioning or something is interfering with the reception of the navigation signals 44 by the user device 22. In this manner, the GCNS system 20 can monitor the reception of the navigation signals 44 and detect if something is interfering with the reception of the navigation signals 44. If a number of user devices 22 all report to the space segment 31 that the same navigation signals 44 are not being received, the processing apparatus can determine the positions of the multiple user devices 22 based on surveillance signals 64 sent by the multiple user devices 22 and determine the probable location of the interference source. The space segment 31 can then report to a desired recipient that interference is occurring and also the probable location of the interference source.

[0062] Additionally, the space segment 31 can transmit via the C1 signal 52 to the user devices 22 that are not receiving the navigation signals 44 the position of the user device 22 calculated by the processing apparatus based on the surveillance signals 64 broadcast by the user devices 22. In this manner, when a user device 22 is not capable of computing its position based on navigation signals 44 received from the space segment 31, the space segment 31 can inform the user device 22 of its position. Thus, the GCNS system 20 provides redundancy in the determination of a position of a user device 22. Similarly, if one of the ICS signals 50 is not available, the user device 22 can report its autonomously derived position based upon received navigation signals 44 to the space segment 31 via the ICS signal 50 that is available.

[0063] The combination of navigation capabilities along with communication/surveillance capabilities provides significant capabilities to the GCNS system 20. The integrated communications capability provides connectivity to the monitoring stations 24. This saves the cost of a ground based network to connect the monitoring stations 24 to the processing apparatus. This architecture also enables a large, reconfigurable network of potentially simple monitoring stations 24. The surveillance signals 64 provide independent measurements of the ionospheric delay. In this way, every user device 22 can function as a monitoring station for ionospheric delay measurements. This will allow airplanes having a user device 22 on board that are flying over the ocean to provide measurement data about the state of the ionosphere 46 where no ground base monitoring station 24 is practical. Connecting the satellites 30 by cross links 40 supports satellite to satellite ranging for autonomous precise ephemeris determination and monitoring. Also, very precise orbit information can be generated and provided as a service for a fee. The two-way ranging provides redundancy for integrity monitoring. For surveillance applications, the user device 22 can broadcast its best estimate of its position. The GCNS system 20 can also independently measure the position of the user device 22. The two positions can be compared in order to detect integrity failures.

[0064] The ionospheric measurements and precise ephemeris may enable tropospheric measurements to be made, both by simple monitoring stations 24 and by the GCNS system 20 itself based on the surveillance ranging capability. If a sufficient number of user devices 22 or monitoring stations 24 are used in the GCNS system 20, a tomography of the ionosphere 66 can be created due to the large numbers of different lines of sight between the user devices 22 and/or monitoring stations 24 and the satellites 30. The ionospheric delay information can be also used to estimate water vapor content of the atmosphere. Furthermore, if other meteorological sensors are integrated into the relatively simple monitoring stations 24, the monitoring stations 24 should enable the development of a large reconfigurable network of meteorological stations.

[0065] The description of the invention is merely exemplary in nature and, thus, variations that do not depart from the gist of the invention are intended to be within the scope of the invention. Such variations are not to be regarded as a departure from the spirit and scope of the invention.

1-10. (canceled)

11. A system for providing integrated communications, navigation and surveillance information, the system comprising:

a plurality of time synchronized satellites networked together, each of said satellites broadcasting navigation signals and being capable of two way communication and of relaying surveillance signals; and

at least one mobile user device, for communicating with said satellites, said user device receiving said navigation signals broadcast by said satellites and using said received navigation signals to compute a position of said user device, and

wherein each of said satellites broadcasts a first navigation signal at a first frequency and sends a communication signal at said first frequency, and said first navigation signal acts as a pilot tone for the system.

12. The system of claim 11, wherein said pilot tone operates for initial acquisition of said user device.

13. The system of claim 11, wherein said each of said satellites broadcasts three navigation signals at three different frequencies, one of said three different frequencies being said first frequency.

14. The system of claim 11, wherein said user device is capable of broadcasting a surveillance signal to said satellites, and further comprising a processing apparatus capable of two way communication with any of said satellites through said network, said processing apparatus receiving surveillance signals relayed by said satellites and determining a position of said user device that broadcast said surveillance signal.

15. The system of claim 11, wherein each of said satellites has communication switching capabilities so that each of said satellites can route communication signals to a desired recipient.

16. The system of claim 11, wherein said network is formed by each of said satellites directly communicating with at least two other of said satellites so that redundant communication paths exist and each of said satellites is capable of communicating with any other of said satellites either directly or through said network.

17-27. (canceled)

28. An integrated communications, navigation and surveillance information system comprising:

a plurality of satellites operable to broadcast navigation signals and a communication signal; and

at least one user device operable to receive said navigation signals and determine its position based on said received navigation signals, wherein said satellites broadcast a first one of said navigation signals and said communication signal at a common frequency, and said first navigation signal acts as pilot tone for initial acquisition of said navigational signals by said user device with the system.

29. The system of claim 28, wherein said satellites broadcast second and third ones of said navigation signals at different frequencies than said first navigation signal.

30. The system of claim 29, wherein said satellites broadcast three navigation signals each at a different frequency.

31. The system of claim 28, wherein the user device is operable to broadcast a communication signal to said satellites at a frequency different than that of said communication signal broadcast by said satellites and can engage in two-way communication with said satellites.

32. The system of claim 31, wherein said user device is operable to broadcast two communications signals and further comprising a processing apparatus operable to determine a position of said user device based upon said communication signals broadcast by said user device.

33. The system of claim 28, wherein said satellites are networked together.

34. The system of claim 28, wherein said user device is a mobile user device.

35. The system of claim 28, wherein said user device registers itself with the system in response to receipt of said pilot tone.

36. A method of acquiring and synchronizing a user device with an integrated communications, navigation and surveillance system, the method comprising:

(a) broadcasting a communication signal from a plurality of satellites at a first frequency;

(b) broadcasting navigation signals from said plurality of satellites, one of said navigation signals being broadcast at said first frequency and serving as a pilot tone;

(c) receiving said broadcast navigation signals with the user device; and

(d) acquiring the user device with the system in response to the user device receiving said pilot tone.

37. The method of claim 36, further comprising broadcasting at least one communication signal from the user device to said satellites.

38. The method of claim 37, further comprising determining a position of said user device based upon said communication signal.

39. The method of claim 36, wherein (b) includes broadcasting at least two navigation signals from said satellites at frequencies other than said first frequency.

40. The method of claim 36, further comprising determining a position of the user device based upon navigation signals received by the user device.

41. The method of claim 40, further comprising reporting said determined position of the user device to the system.

* * * * *