



US 20060265058A1

(19) **United States**

(12) **Patent Application Publication**
Silvestrini

(10) **Pub. No.: US 2006/0265058 A1**

(43) **Pub. Date: Nov. 23, 2006**

(54) **CORNEAL MASK FORMED OF
DEGRADATION RESISTANT POLYMER AND
PROVIDING REDUCED CORNEAL
DEPOSITS**

Publication Classification

(51) **Int. Cl.**
A61F 2/14 (2006.01)
G02C 7/16 (2006.01)
A61F 2/16 (2006.01)
(52) **U.S. Cl.** **623/5.13; 623/5.16; 351/163;
623/6.17**

(76) Inventor: **Thomas A. Silvestrini**, Alamo, CA
(US)

(57) **ABSTRACT**

Correspondence Address:
KNOBBE MARTENS OLSON & BEAR LLP
2040 MAIN STREET
FOURTEENTH FLOOR
IRVINE, CA 92614 (US)

Disclosed are masks configured to be implanted in a cornea of a patient. In one embodiment, the body of the mask has a light transmitting portion, a light blocking portion disposed about the light transmitting portion, and an outer periphery surrounding the light blocking portion. The mask is adapted to reside between two intracorneal layers of a cornea. In a preferred embodiment, the mask is formed from a material comprising a highly fluorinated polymeric material and an opacification agent and is resistant to degradation upon exposure to ultraviolet light. In another embodiment, the mask is formed from a material which comprises a polyanionic compound. In some embodiments, the mask includes one or more wound healing modulator compounds to aid in proper healing following implantation.

(21) Appl. No.: **11/404,048**

(22) Filed: **Apr. 13, 2006**

Related U.S. Application Data

(63) Continuation-in-part of application No. 11/106,043,
filed on Apr. 14, 2005.

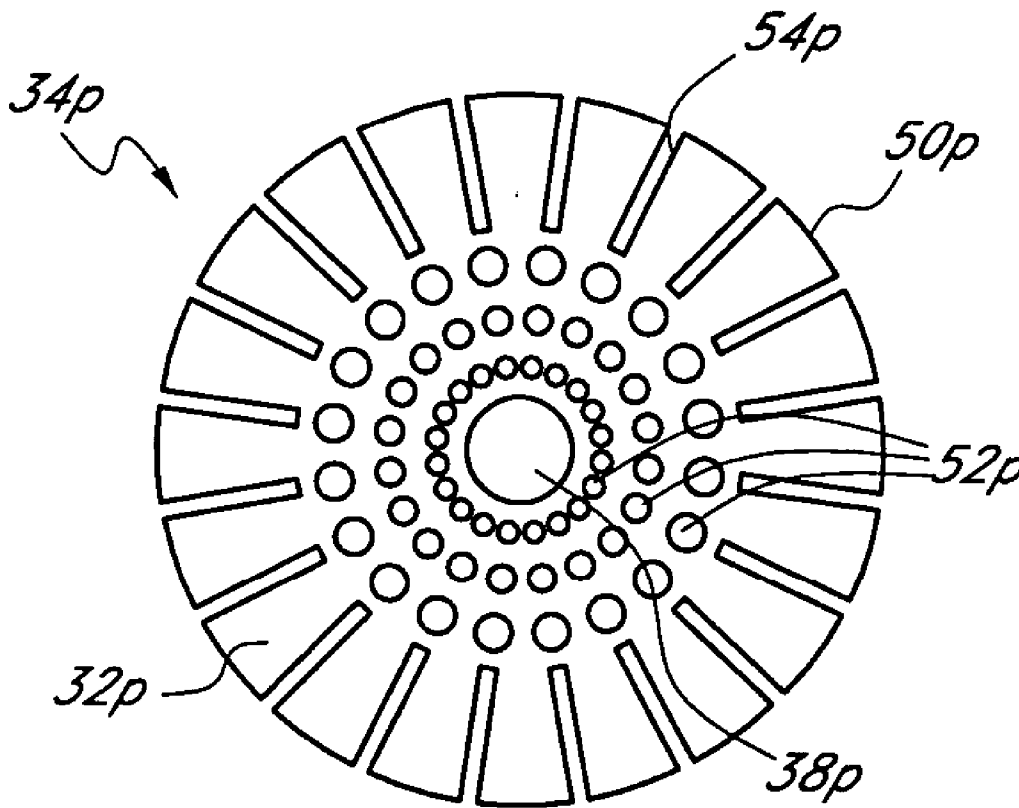

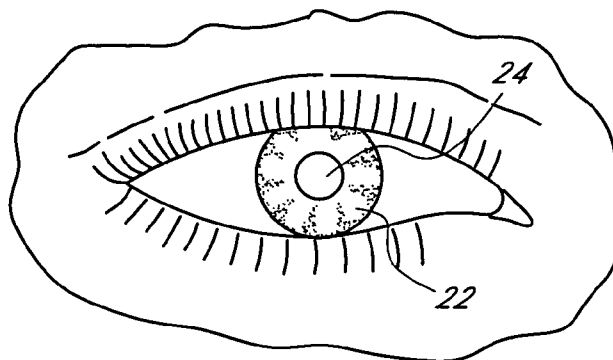

FIG. 1

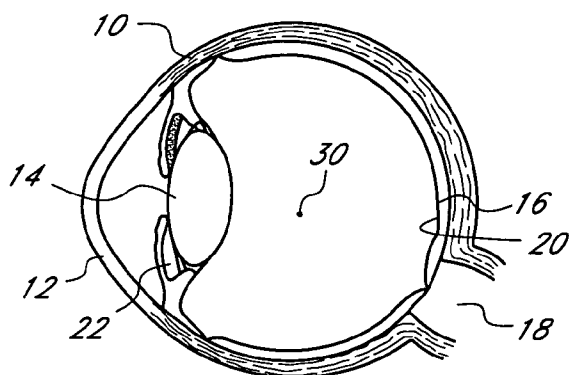

FIG. 2

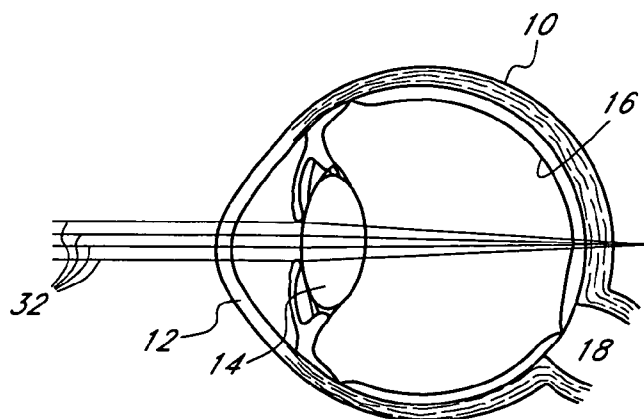

FIG. 3

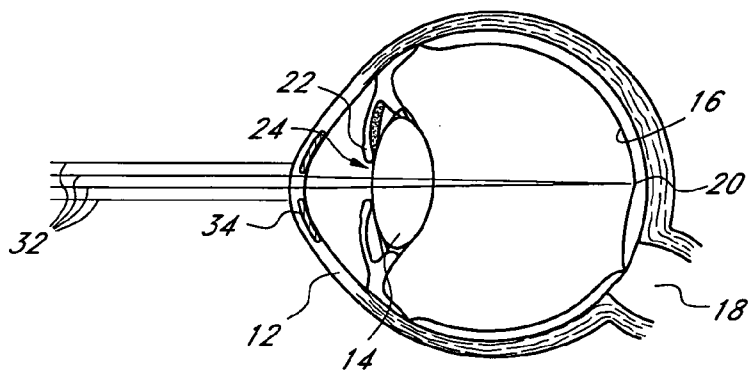

FIG. 4

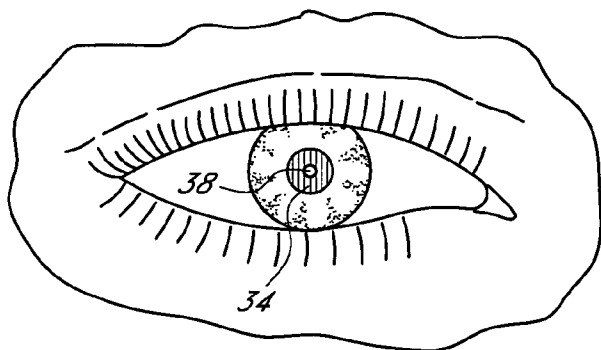

FIG. 5

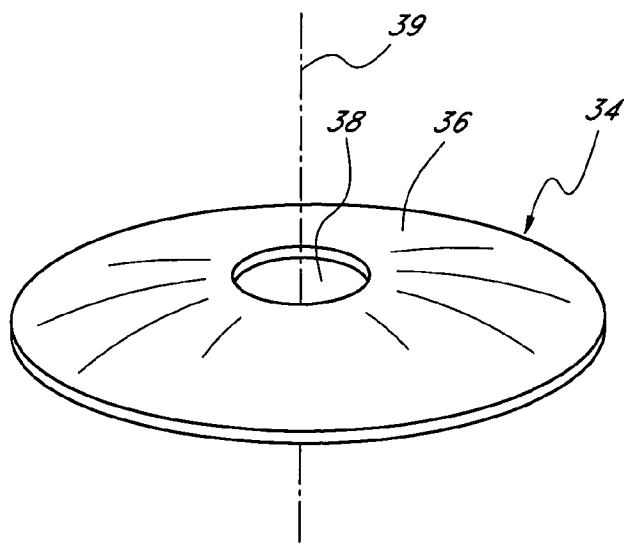

FIG. 6

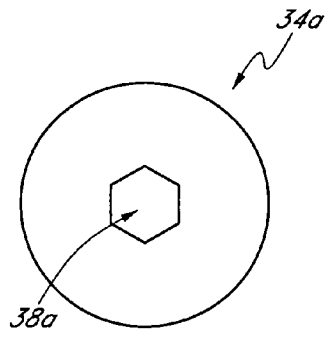

FIG. 7

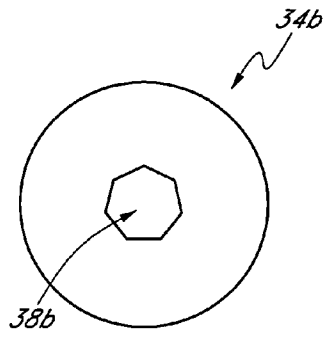

FIG. 8

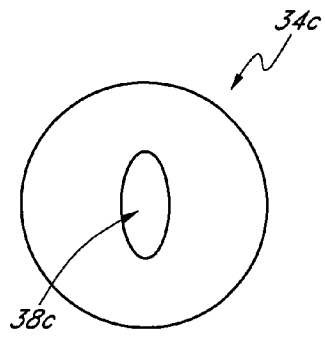

FIG. 9

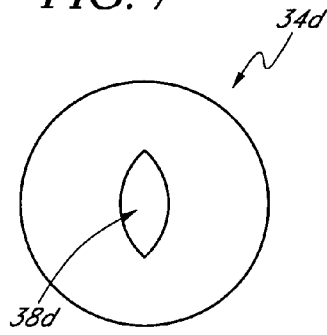

FIG. 10

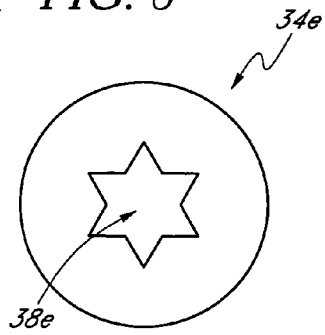

FIG. 11

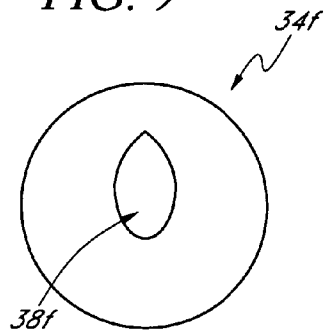

FIG. 12

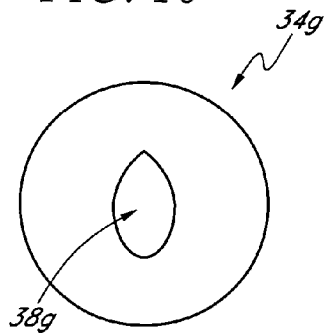

FIG. 13

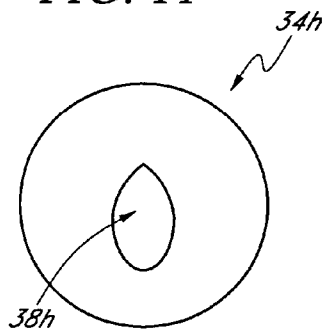

FIG. 14

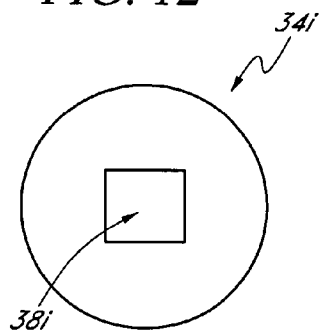

FIG. 15

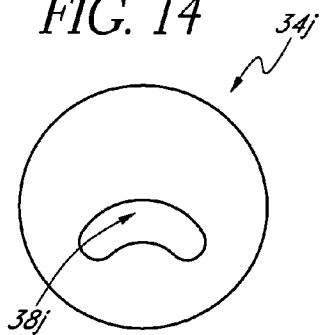

FIG. 16

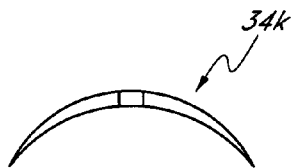

FIG. 17

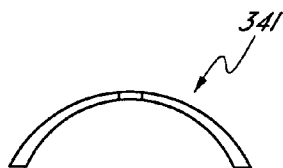

FIG. 18

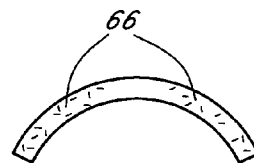

FIG. 19

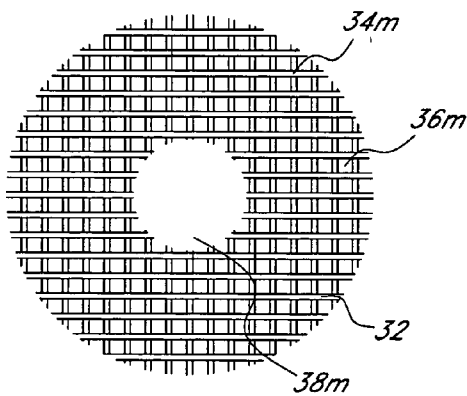

FIG. 20

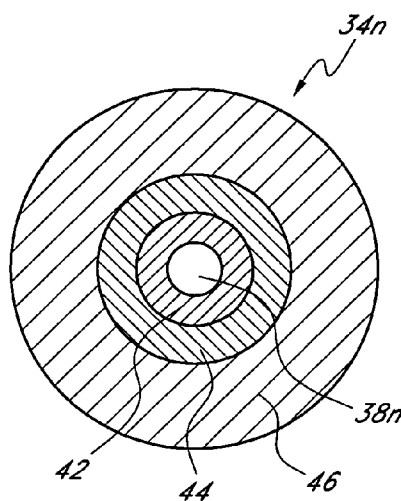

FIG. 22



FIG. 21

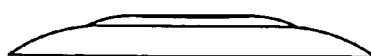

FIG. 23

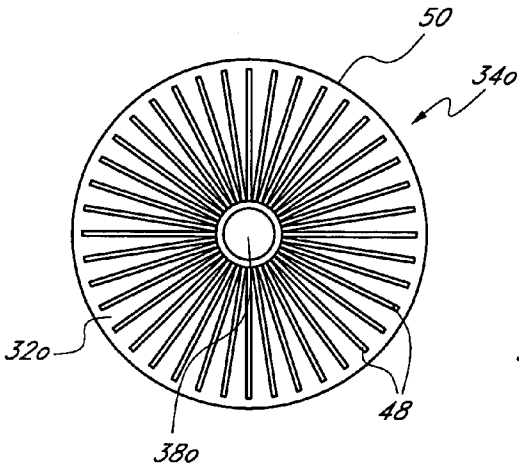

FIG. 24



FIG. 25

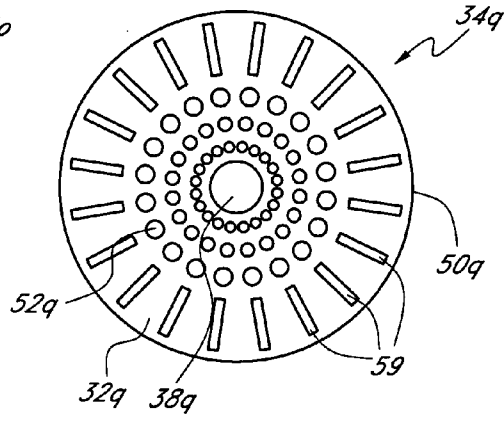

FIG. 28

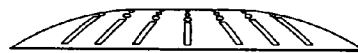

FIG. 29

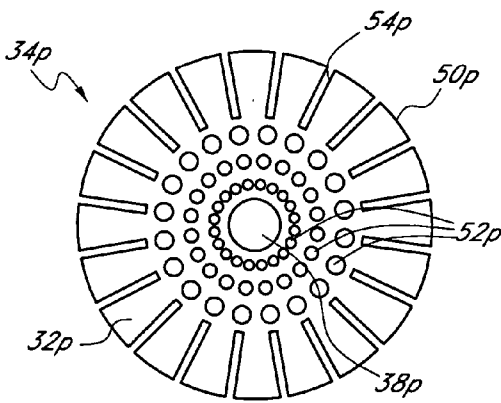

FIG. 26



FIG. 27

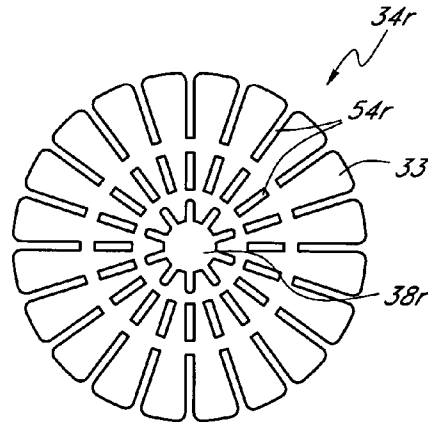

FIG. 30



FIG. 31

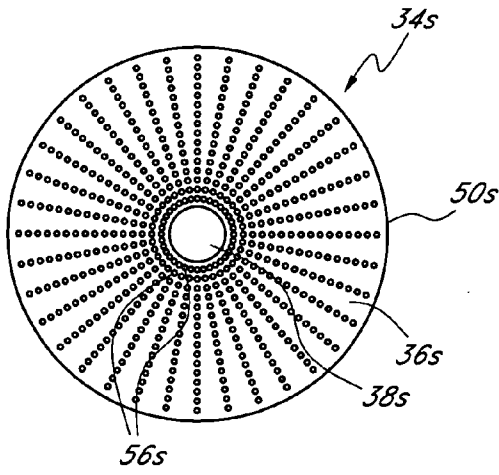

FIG. 32



FIG. 33

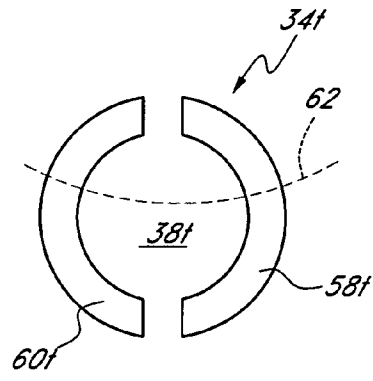

FIG. 34

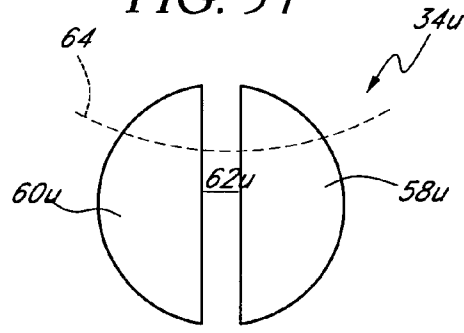

FIG. 35

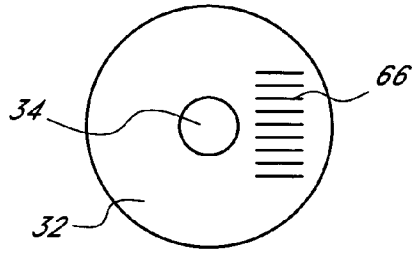

FIG. 39

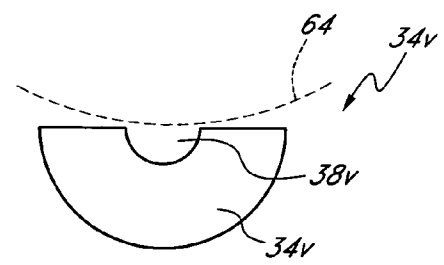

FIG. 36

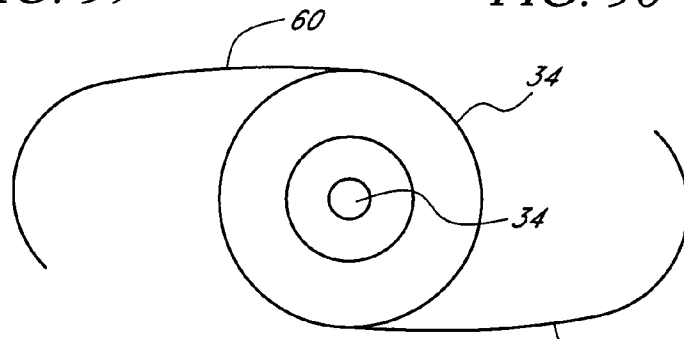

FIG. 40

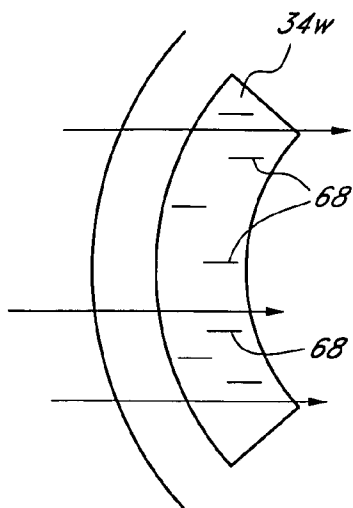

FIG. 37

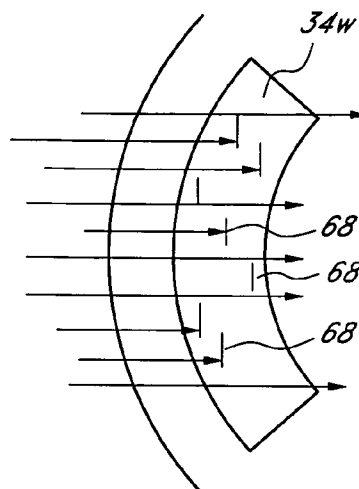

FIG. 38

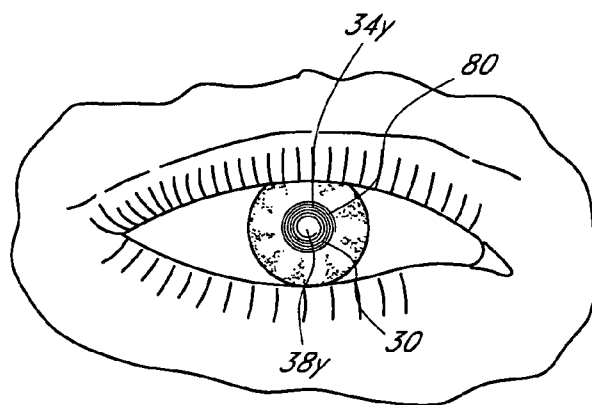

FIG. 41

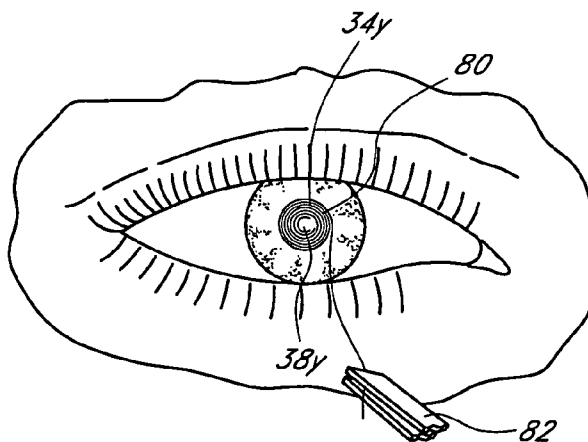

FIG. 42

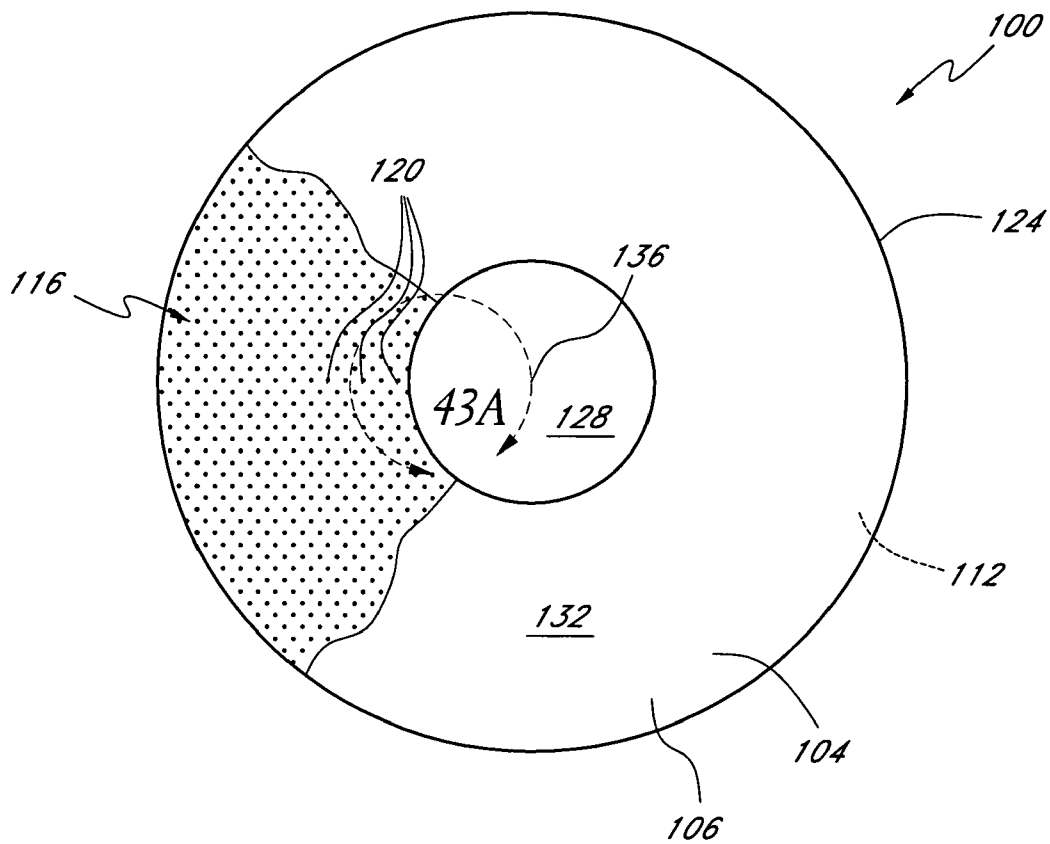

FIG. 43

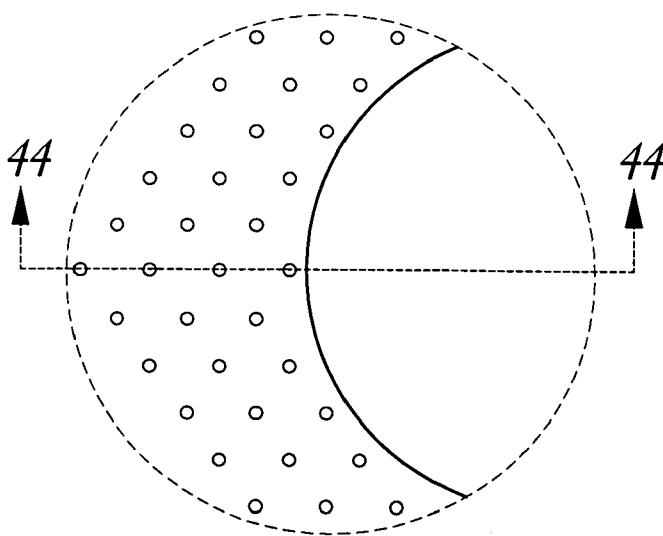

FIG. 43A

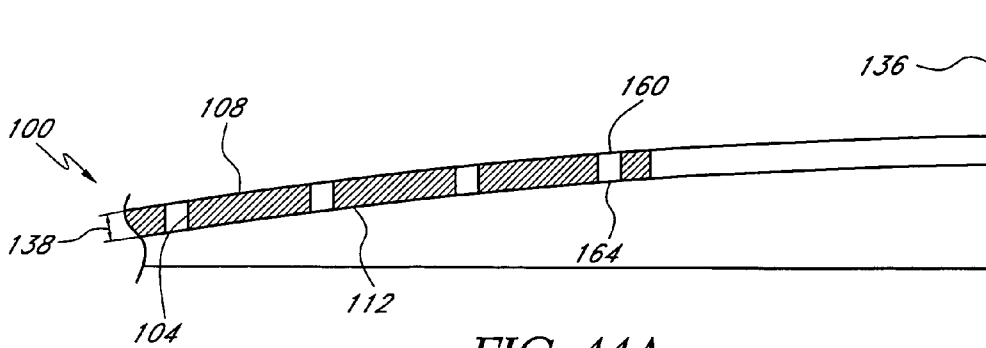

FIG. 44A

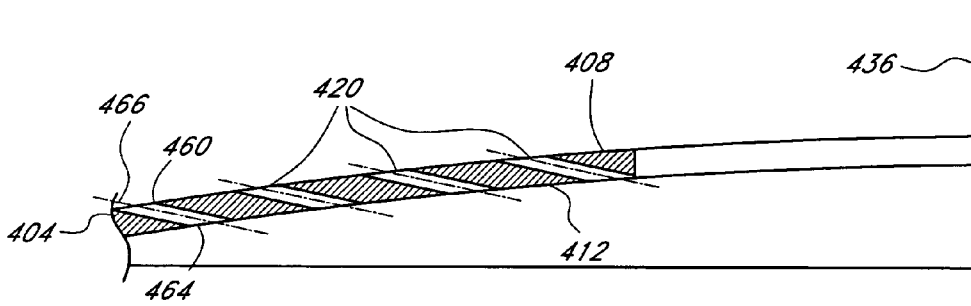

FIG. 44B

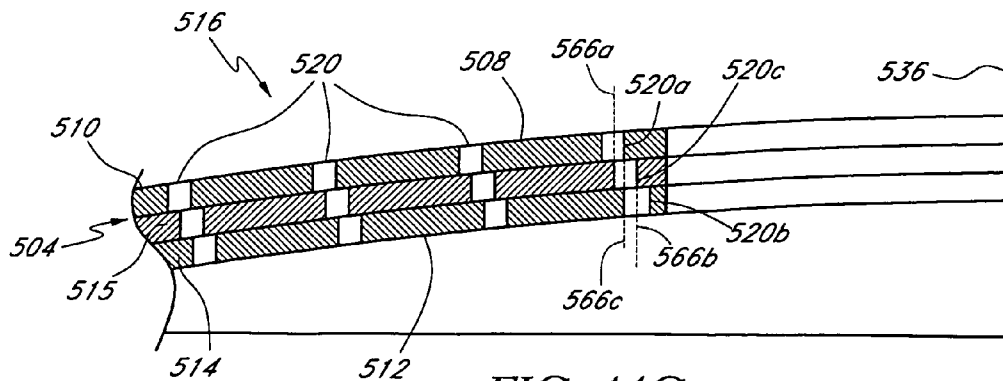

FIG. 44C

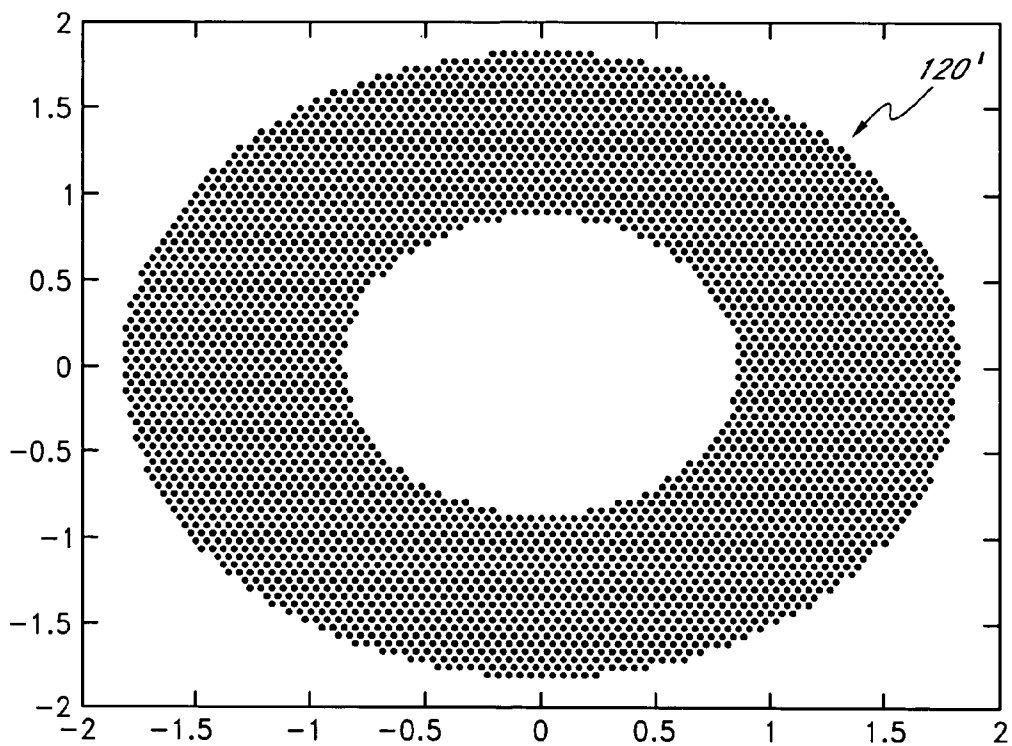

FIG. 45A

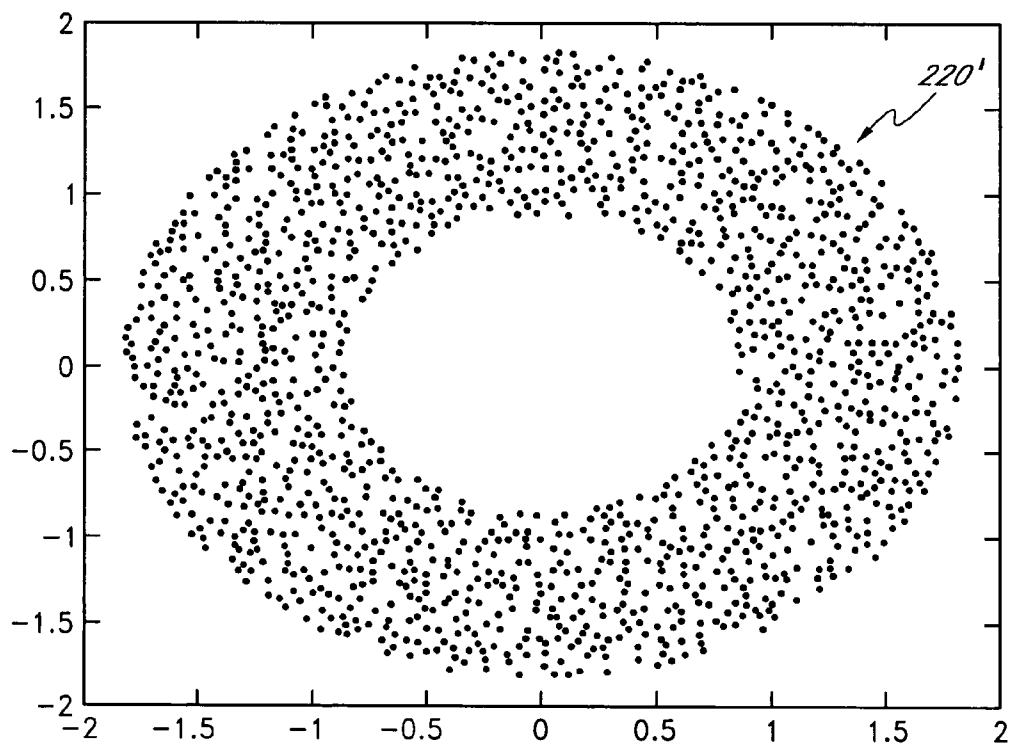

FIG. 45B

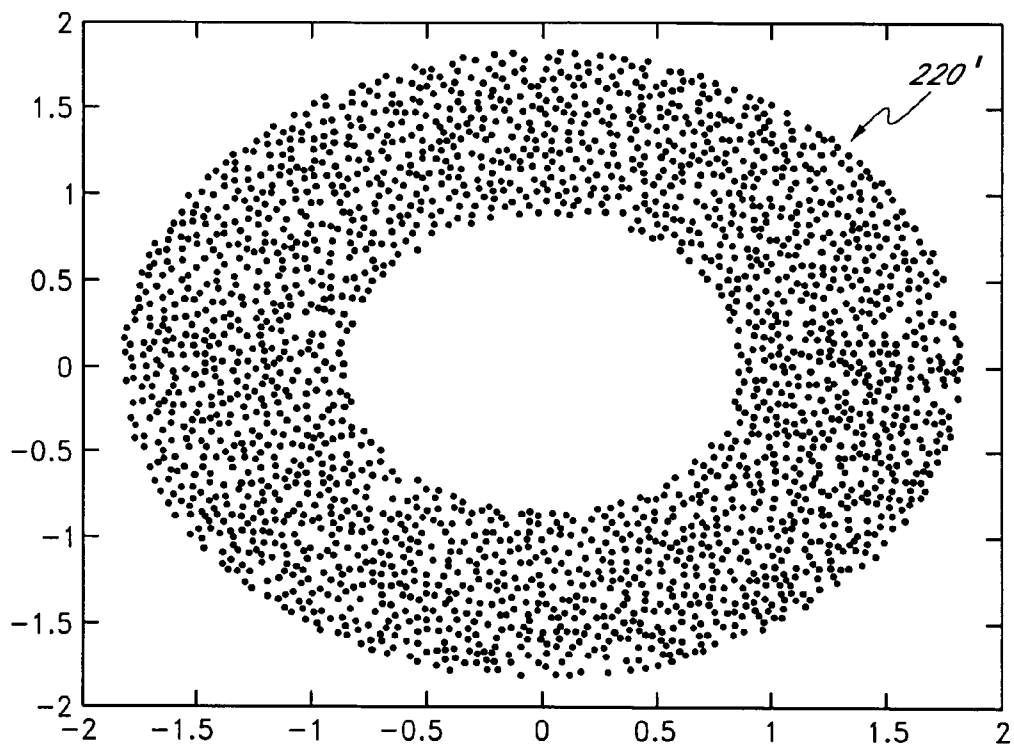

FIG. 45C

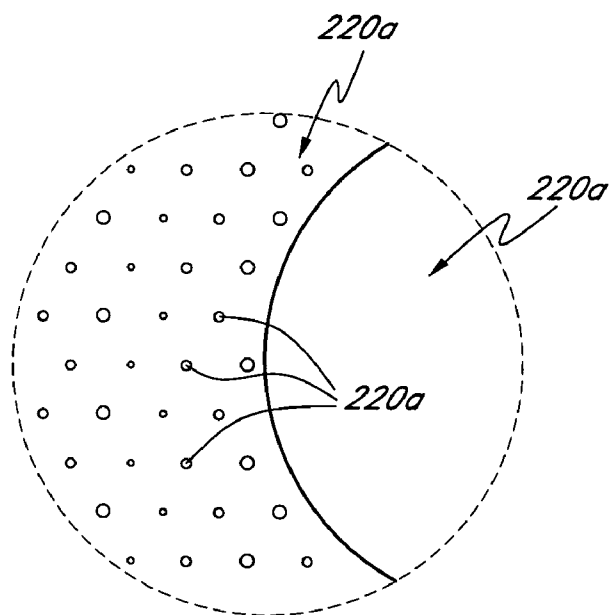

FIG. 46A

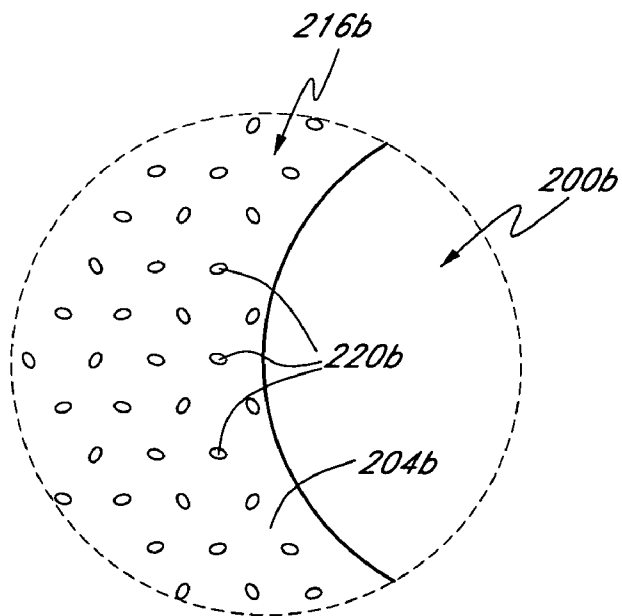

FIG. 46B

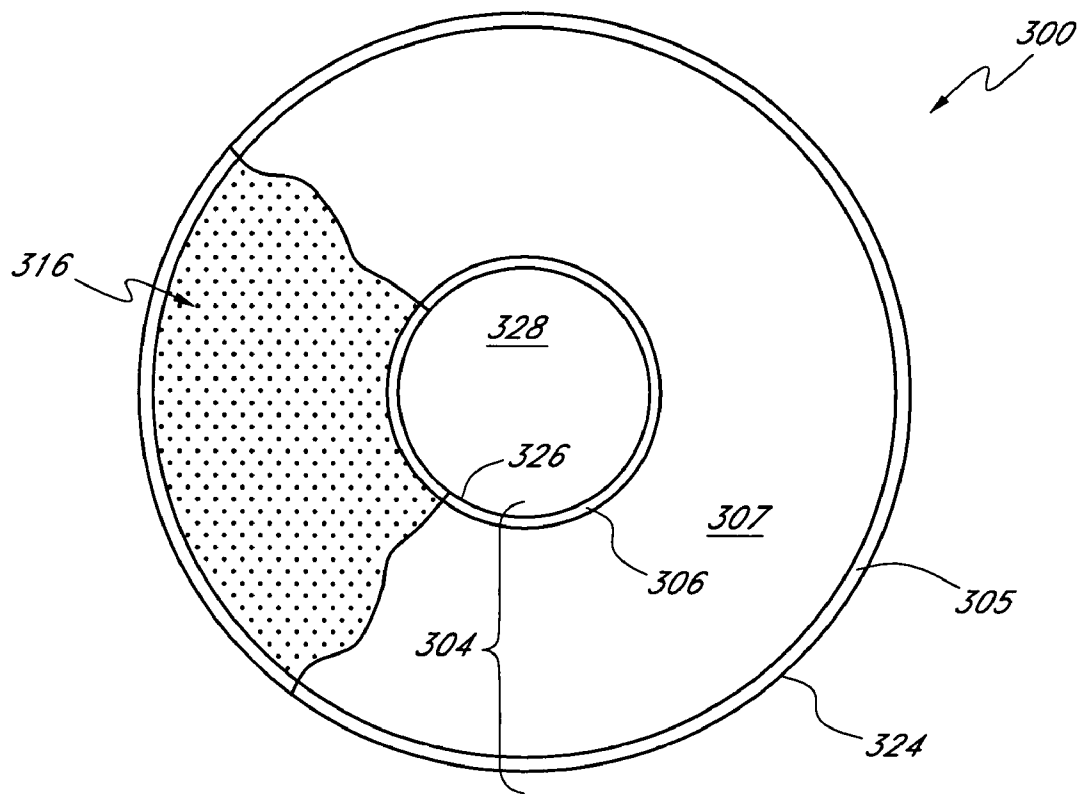

FIG. 47

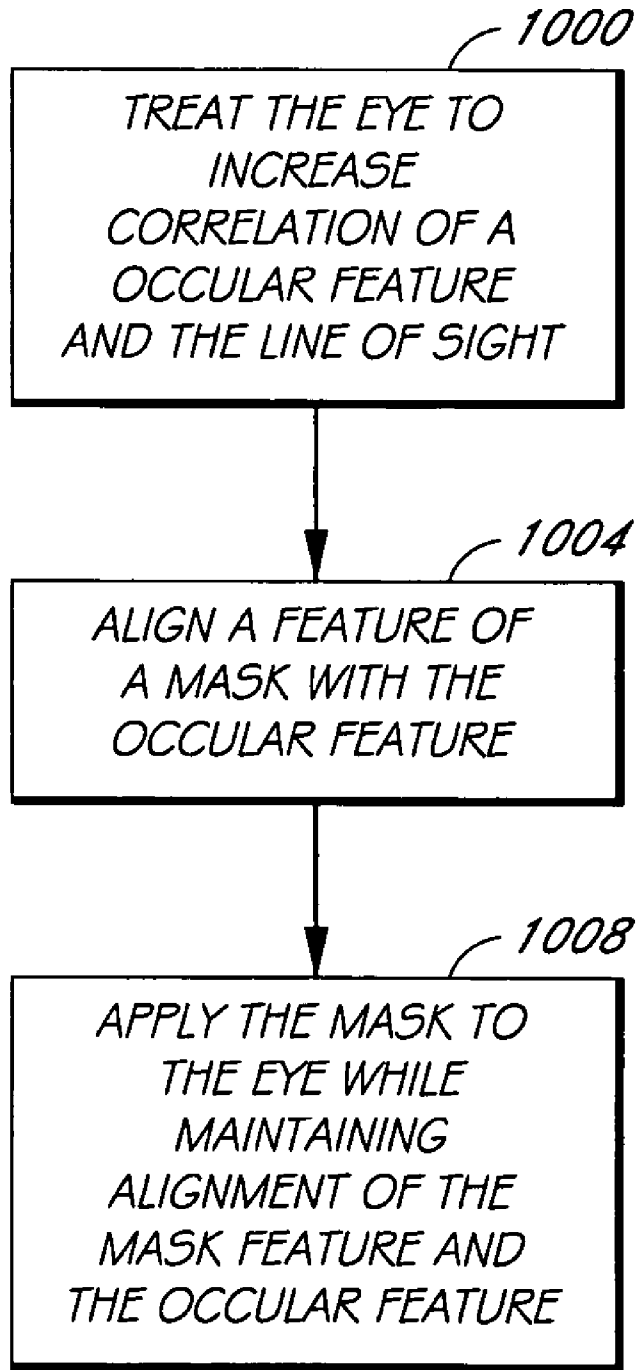

FIG. 48

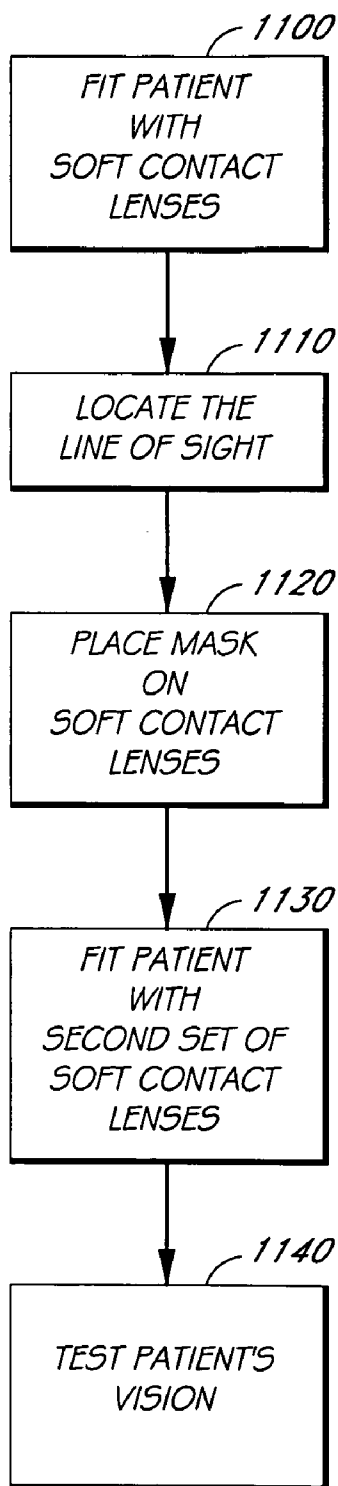

FIG. 49

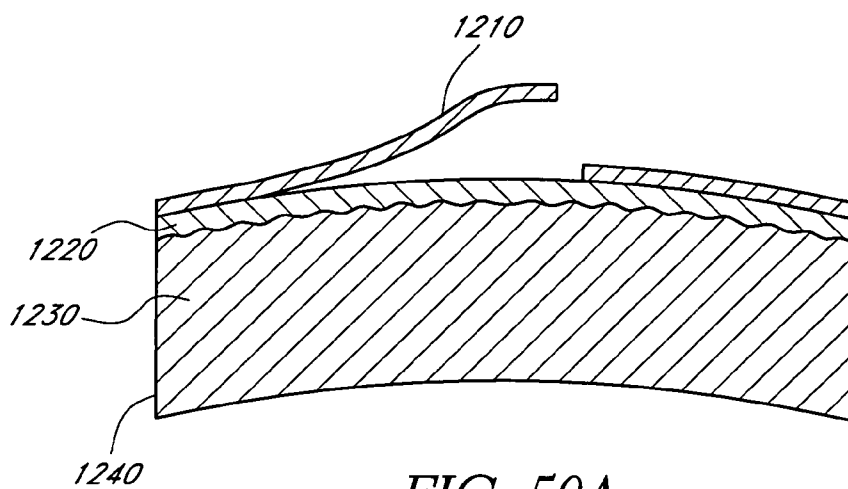

FIG. 50A

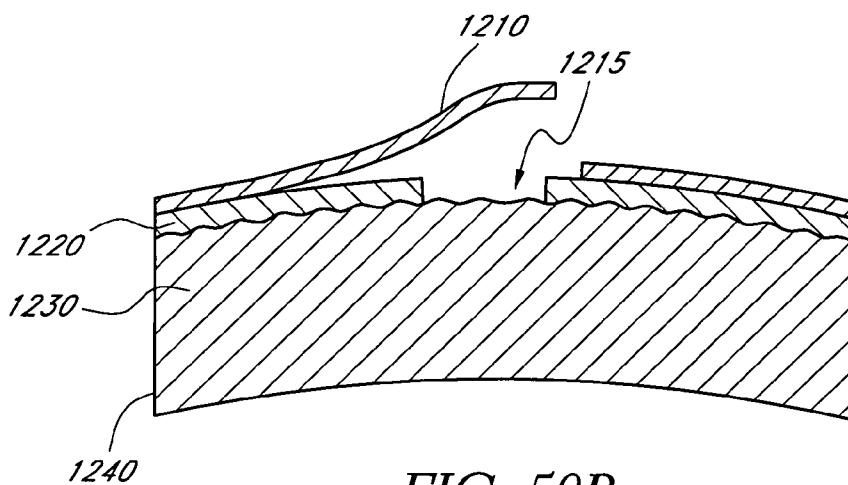

FIG. 50B

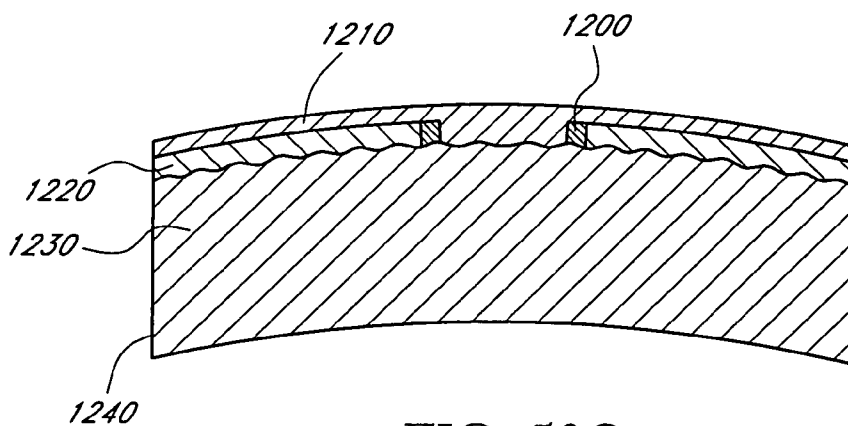

FIG. 50C

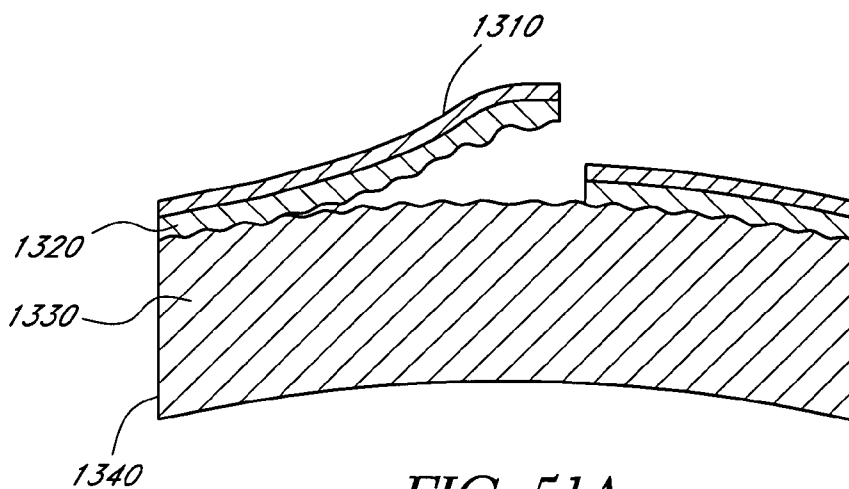

FIG. 51A

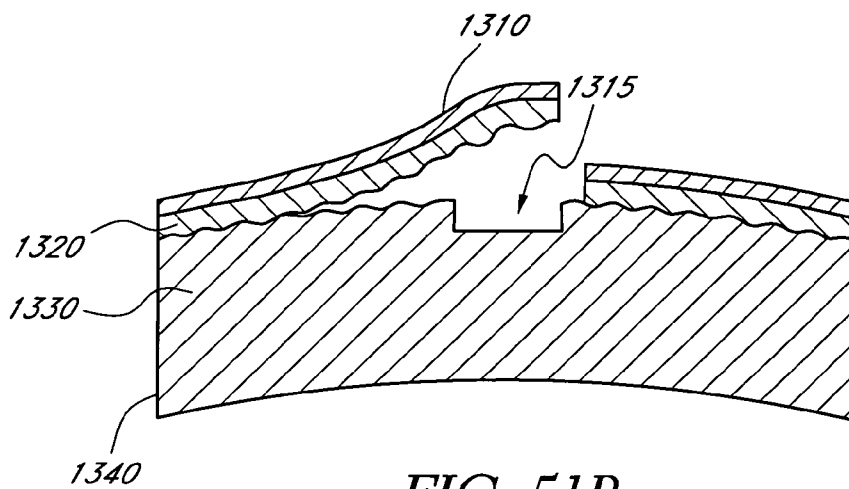

FIG. 51B

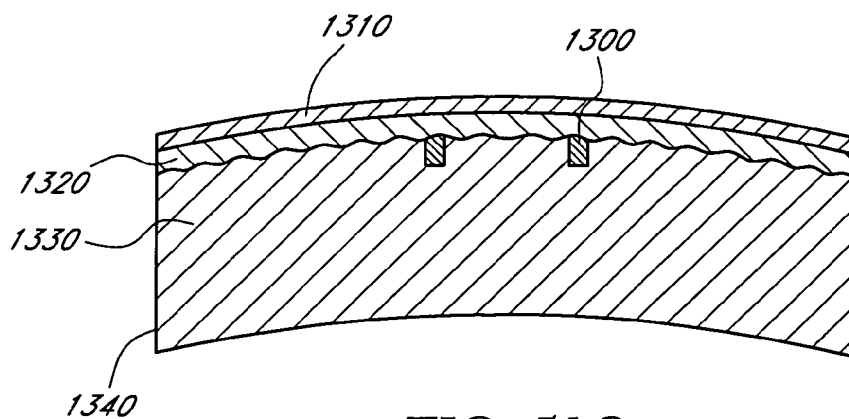

FIG. 51C

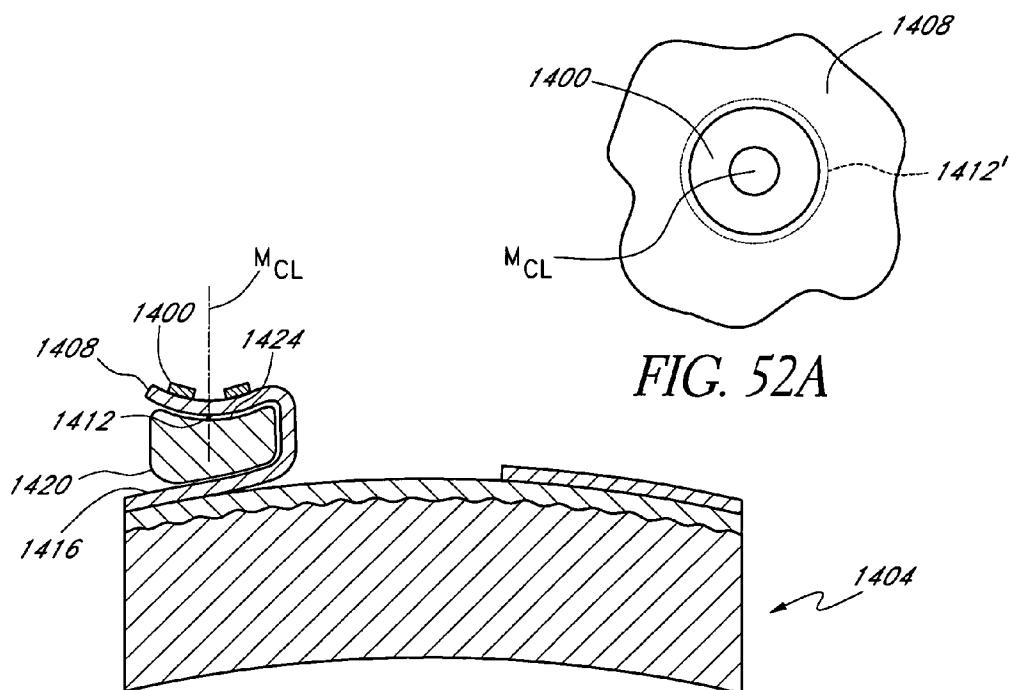

FIG. 52

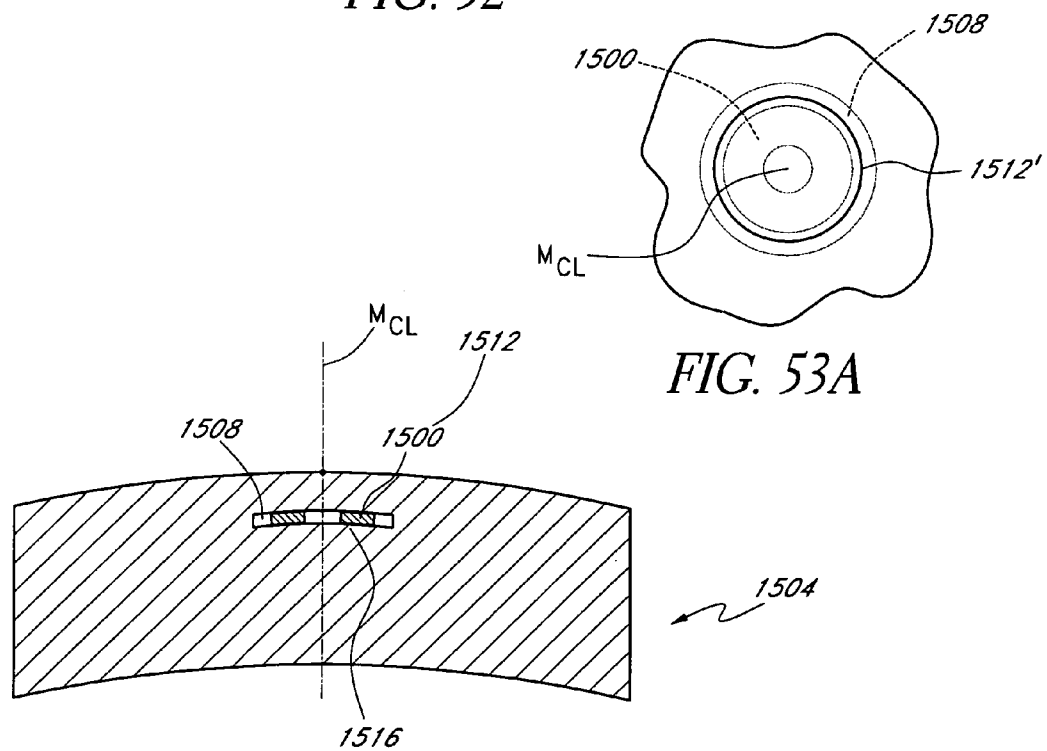

FIG. 53

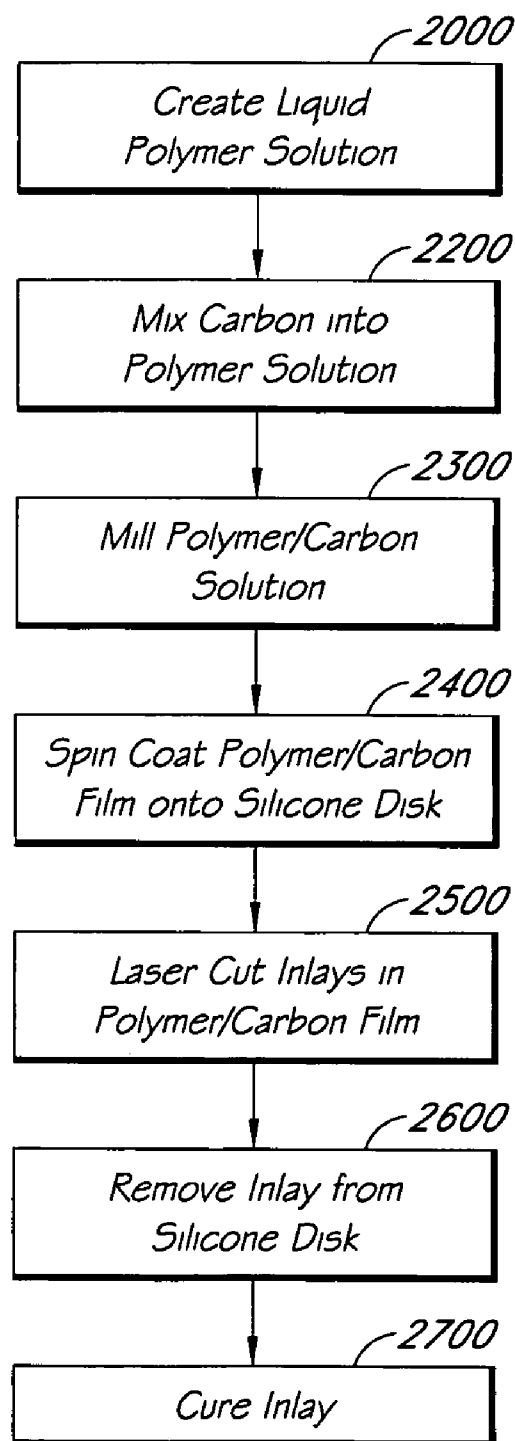

FIG. 54

**CORNEAL MASK FORMED OF DEGRADATION
RESISTANT POLYMER AND PROVIDING
REDUCED CORNEAL DEPOSITS**

RELATED APPLICATION INFORMATION

[0001] This application is a continuation-in-part of U.S. patent application Ser. No. 11/106,043, filed Apr. 14, 2005, the disclosure of which is hereby incorporated by reference in its entirety.

BACKGROUND OF THE INVENTION

[0002] 1. Field of the Invention

[0003] This application is related to corneal inlay devices. More particularly, this application is directed to corneal inlays that are configured not to degrade over the useful life of the inlay, and that can include one or more compounds to aid in proper healing following implantation and/or include one or more materials which reduce the amount of corneal deposits formed thereon as compared to a mask without such material.

[0004] 2. Description of the Related Art

[0005] A normally functioning human eye is capable of selectively focusing on either near or far objects through a process known as accommodation. Accommodation is achieved by inducing deformation in a lens located inside the eye, which is normally referred to as the "intraocular lens". Such deformation is induced by muscles called ciliary muscles. As some individuals age, the ability to accommodate diminishes and these individuals cannot see up close without vision correction. If far vision also is deficient, such individuals are prescribed bifocal lenses.

[0006] While this approach is sometimes satisfactory, some have proposed implanting devices inside the eye to improve accommodation for older patients. One such implant is a pin-hole imaging device that can be implanted in the cornea of an eye. While this type of device has been discussed in various contexts, and a need for the device has been identified, no such device is currently on the market.

[0007] Several factors make a successful device of this type elusive. In particular, the device needs to improve the depth of field of a patient's vision and, because it is surgically implanted, the device has to have a very long life-span. No known device has been proposed that has an adequate life-span.

[0008] Because corneal implants are exposed to a great deal of sunlight during their lifetime, resistance to degradation of the polymer due to UV exposure is important. In the contact lens and IOL arts, commercially available stabilizers have been added to the lenses to prevent degradation of the lenses due to this exposure and also to exposure to UV light used as a means of sterilization. Stabilizers dissipate the energy of ultraviolet rays to prevent degradation of the lens material. The stabilizers may be physically combined with the polymer or they may be part of a monomer which is copolymerizable with the polymeric material which forms the lens. Copolymerization reduces extractability, a problem with many stabilizers that are merely physically combined with a polymer.

SUMMARY OF THE INVENTION

[0009] Notwithstanding the foregoing, there remains a need for a mask, such as a corneal inlay device, that is

sufficiently resistant to degradation of the type described above and for this and other similar applications.

[0010] In preferred embodiments, a mask includes a polyanionic compound and/or a wound healing modulator compound. In accordance with a preferred embodiment, there is provided a mask configured to be implanted in a cornea of a patient. The mask comprises a body formed from a polymeric material, the body having a light transmitting portion, a light blocking portion disposed about the light transmitting portion, an anterior surface, and a posterior surface, the anterior surface configured to reside adjacent a first intracorneal layer, the posterior surface configured to reside adjacent a second intracorneal layer, wherein the polymeric material includes one or more polyanionic compounds and/or wound healing modulator compounds, preferably loaded into the polymeric material.

[0011] In accordance with a preferred embodiment, there is provided a mask configured to be implanted in a cornea of a patient. The mask comprises a body formed from a material comprising a polymeric material, preferably a highly fluorinated polymeric material, the body having a light transmitting portion, a light blocking portion disposed about the light transmitting portion, an anterior surface, and a posterior surface, the anterior surface configured to reside adjacent a first intracorneal layer, the posterior surface configured to reside adjacent a second intracorneal layer, wherein the material comprising a polymeric material has loaded therein one or more polyanionic compounds. In a preferred embodiment, the total weight of the one or more polyanionic compounds is about 10% to 20% by weight.

[0012] The material forming the light blocking portion of the body may be of a type which comprises an opacification agent selected from the group consisting of organic dyes organic pigments, inorganic dyes, and inorganic pigments. In one preferred embodiment, the opacification agent comprises carbon. In a preferred embodiment, the mask includes at least one wound healing modulator compound.

[0013] In preferred embodiments, the mask includes an outer periphery surrounding the light blocking portion.

[0014] In accordance with a preferred embodiment, there is provided a mask comprising an aperture, preferably having a major axis of about 2.2 mm or less and an annular body extending between the aperture and an outer periphery of the mask. In a preferred embodiment, the annular body has an anterior surface and a posterior surface and is formed of a material comprising a polymeric material, preferably a highly fluorinated polymeric material, an opacification agent, and one or more polyanionic compounds and/or wound healing modulator compounds. The opacification agent is preferably present in sufficient quantity to prevent at least a substantial portion of light incident on the anterior surface from being transmitted from the anterior surface to the posterior surface. In a preferred embodiment, the anterior surface is configured to reside adjacent a first intracorneal layer of a cornea, and the posterior surface is configured to reside adjacent a second intracorneal layer. Other preferred embodiments may include one or more of the following features: a mask which does not substantially alter the curvature of a cornea following application of the mask to a cornea; an annular body that has a substantially constant thickness between the anterior and posterior surfaces, preferably of about 20 microns or less.

[0015] In accordance with a preferred embodiment, there is provided a mask configured to be implanted in a cornea of a patient. The mask comprises a body formed from a polymeric material, the body having a light transmitting portion, a light blocking portion disposed about the light transmitting portion, an anterior surface configured to reside adjacent a first intracorneal layer, a posterior surface configured to reside adjacent a second intracorneal layer, and at least one polyanionic compound and/or wound healing modulator. A wound healing modulator, if present, is preferably bound to at least one of the anterior surface and the posterior surface.

[0016] Preferred embodiments of the embodiments discussed above may have one or more additional properties. Preferred wound healing modulator compounds include, without limitation, antibiotics, antineoplastics including antimetabolites, antimetabolites and antibiotic types, anti-inflammatories, immunosuppressants, and antifungals. Preferred compounds include, but are not limited to, fluorouracil, mitomycin C, paclitaxel, NSAIDs (e.g. ibuprofen, naproxen, flurbiprofen, carprofen, suprofen, ketoprofen), and cyclosporins. Other preferred compounds include proteoglycans, glycosaminoglycans, and salts and derivatives thereof, as well as other carbohydrates and/or proteins. The wound healing modulator compound may be loaded into the polymer and/or adsorbed or coated onto at least one surface. In one embodiment, at least a portion of the wound healing modulator compound is adsorbed to a carbon opacification agent. In preferred embodiments, the polymeric material is UV-resistant, and preferably comprises a highly fluorinated polymeric material such as polyvinylidene fluoride (PVDF).

[0017] In preferred embodiments, the total weight of the one or more polyanionic compounds is about 0.1% by weight to about 50% by weight, including about 5% by weight to about 20% by weight, about 12% by weight to about 17% by weight, about 0.5% by weight to about 4% by weight, and about 5% by weight to about 15% by weight. Preferred polyanionic compounds include carbohydrates, proteins, natural proteoglycans, and/or the glycosaminoglycan moieties of proteoglycans, as well as derivatives (such as sulfated derivatives) and salts of compounds such as those in the recited categories. Preferred polyanionic compounds include one or more of dermatan sulfate, chondroitin sulfate, keratan sulfate, heparan sulfate, heparin, dextran sulfate, hyaluronic acid, pentosan polysulfate, xanthan, carrageenan, fibronectin, laminin, chondronectin, vitronectin, poly L-lysine salts, and anionic, preferably sulfated, carbohydrates such as alginate may also be used, as well as salts and derivatives of the listed compounds. Examples of preferred anionic compounds and combinations of polyanionic compounds include keratan sulfate/chondroitin sulfate-proteoglycan, dermatan sulfate proteoglycan, and dextran sulfate.

BRIEF DESCRIPTION OF THE DRAWINGS

[0018] FIG. 1 is a plan view of the human eye.

[0019] FIG. 2 is a cross-sectional side view of the human eye.

[0020] FIG. 3 is a cross-sectional side view of the human eye of a presbyopic patient wherein the light rays converge at a point behind the retina of the eye.

[0021] FIG. 4 is a cross-sectional side view of a presbyopic eye implanted with one embodiment of a mask wherein the light rays converge at a point on the retina.

[0022] FIG. 5 is a plan view of the human eye with a mask applied thereto.

[0023] FIG. 6 is a perspective view of one embodiment of a mask.

[0024] FIG. 7 is a frontal plan view of an embodiment of a mask with a hexagon-shaped pinhole like aperture.

[0025] FIG. 8 is a frontal plan view of an embodiment of a mask with an octagon-shaped pinhole like aperture.

[0026] FIG. 9 is a frontal plan view of an embodiment of a mask with an oval-shaped pinhole like aperture.

[0027] FIG. 10 is a frontal plan view of an embodiment of a mask with a pointed oval-shaped pinhole like aperture.

[0028] FIG. 11 is a frontal plan view of an embodiment of a mask with a star-shaped pinhole like aperture.

[0029] FIG. 12 is a frontal plan view of an embodiment of a mask with a teardrop-shaped pinhole like aperture spaced above the true center of the mask.

[0030] FIG. 13 is a frontal plan view of an embodiment of a mask with a teardrop-shaped pinhole like aperture centered within the mask.

[0031] FIG. 14 is a frontal plan view of an embodiment of a mask with a teardrop-shaped pinhole like aperture spaced below the true center of the mask.

[0032] FIG. 15 is a frontal plan view of an embodiment of a mask with a square-shaped pinhole like aperture.

[0033] FIG. 16 is a frontal plan view of an embodiment of a mask with a kidney-shaped oval pinhole like aperture.

[0034] FIG. 17 is a side view of an embodiment of a mask having varying thickness.

[0035] FIG. 18 is a side view of another embodiment of a mask having varying thickness.

[0036] FIG. 19 is a side view of an embodiment of a mask with a gel to provide opacity to the lens.

[0037] FIG. 20 is frontal plan view of an embodiment of a mask with a weave of polymeric fibers.

[0038] FIG. 21 is a side view of the mask of FIG. 20.

[0039] FIG. 22 is a frontal plan view of an embodiment of a mask having regions of varying opacity.

[0040] FIG. 23 is a side view of the mask of FIG. 22.

[0041] FIG. 24 is a frontal plan view of an embodiment of a mask that includes a centrally located pinhole like aperture and radially extending slots emanating from the center to the periphery of the mask.

[0042] FIG. 25 is a side view of the mask of FIG. 24.

[0043] FIG. 26 is a frontal plan view of an embodiment of a mask that includes a central pinhole like aperture, surrounded by a plurality of holes radially spaced from the pinhole like aperture and slots extending radially spaced from the holes and extending to the periphery of the mask.

[0044] FIG. 27 is a side view of the mask of FIG. 26.

[0045] **FIG. 28** is a frontal plan view of an embodiment of a mask that includes a central pinhole like aperture, a region that includes a plurality of holes radially spaced from the aperture, and a region that includes rectangular slots spaced radially from the holes.

[0046] **FIG. 29** is a side view of the mask of **FIG. 28**.

[0047] **FIG. 30** is a frontal plan view of an embodiment of a mask that includes a non-circular pinhole like aperture, a first set of slots radially spaced from the aperture, and a region that includes a second set of slots extending to the periphery of the mask and radially spaced from the first set of slots.

[0048] **FIG. 31** is a side view of the mask of **FIG. 30**.

[0049] **FIG. 32** is a frontal plan view of an embodiment of a mask that includes a central pinhole like aperture and a plurality of holes radially spaced from the aperture.

[0050] **FIG. 33** is a side view of the mask of **FIG. 32**.

[0051] **FIG. 34** is an embodiment of a mask that includes two semi-circular mask portions.

[0052] **FIG. 35** is an embodiment of a mask including two half-moon shaped portions.

[0053] **FIG. 36** is an embodiment of a mask that includes a half-moon shaped region and a centrally-located pinhole like aperture.

[0054] **FIG. 37** is an enlarged, diagrammatic view of an embodiment of a mask that includes particulate structure adapted for selectively controlling light transmission through the mask in a low light environment.

[0055] **FIG. 38** is a view of the mask of **FIG. 37** in a bright light environment.

[0056] **FIG. 39** is an embodiment of a mask that includes a barcode formed on the annular region of the mask.

[0057] **FIG. 40** is another embodiment of a mask that includes connectors for securing the mask within the eye.

[0058] **FIG. 41** is a plan view of an embodiment of a mask made of a spiraled fibrous strand.

[0059] **FIG. 42** is a plan view of the mask of **FIG. 41** being removed from the eye.

[0060] **FIG. 43** is a top view of another embodiment of a mask configured to increase depth of focus.

[0061] **FIG. 43A** is an enlarged view of a portion of the view of **FIG. 43**.

[0062] **FIG. 44A** is a cross-sectional view of the mask of **FIG. 43A** taken along the section plane **44-44**.

[0063] **FIG. 44B** is a cross-sectional view similar to **FIG. 44A** of another embodiment of a mask.

[0064] **FIG. 44C** is a cross-sectional view similar to **FIG. 44A** of another embodiment of a mask.

[0065] **FIG. 45A** is a graphical representation of one arrangement of holes of a plurality of holes that may be formed on the mask of **FIG. 43**.

[0066] **FIG. 45B** is a graphical representation of another arrangement of holes of a plurality of holes that may be formed on the mask of **FIG. 43**.

[0067] **FIG. 45C** is a graphical representation of another arrangement of holes of a plurality of holes that may be formed on the mask of **FIG. 43**.

[0068] **FIG. 46A** is an enlarged view similar to that of **FIG. 43A** showing a variation of a mask having non-uniform size.

[0069] **FIG. 46B** is an enlarged view similar to that of **FIG. 43A** showing a variation of a mask having a non-uniform facet orientation.

[0070] **FIG. 47** is a top view of another embodiment of a mask having a hole region and a peripheral region.

[0071] **FIG. 48** is a flow chart illustrating one method of aligning a mask with an axis of the eye based on observation of an anatomical feature of the eye.

[0072] **FIG. 49** is a flow chart illustrating one method of screening a patient for the use of a mask.

[0073] **FIGS. 50A-50C** show a mask, similar to those described herein, inserted beneath an epithelium sheet of a cornea.

[0074] **FIGS. 51A-51C** show a mask, similar to those described herein, inserted beneath a Bowman's membrane of a cornea.

[0075] **FIG. 52** is a cross-sectional view of an eye illustrating a treatment of a patient wherein a flap is opened to place an implant and a location is marked for placement of the implant.

[0076] **FIG. 52A** is a partial plan view of the eye of **FIG. 52** wherein an implant has been applied to a corneal flap and positioned with respect to a ring.

[0077] **FIG. 53** is a cross-sectional view of an eye illustrating a treatment of a patient wherein a pocket is created to place an implant and a location is marked for placement of the implant.

[0078] **FIG. 53A** is a partial plan view of the eye of **FIG. 53** wherein an implant has been positioned in a pocket and positioned with respect to a ring.

[0079] **FIG. 54** is a flow chart illustrating one method for making a mask from a composition comprising a highly fluorinated polymer and an opacification agent.

DETAILED DESCRIPTION OF THE PREFERRED EMBODIMENT

[0080] This application is directed to masks for improving the depth of focus of an eye of a patient and methods and apparatuses for making such masks. The masks generally employ pin-hole vision correction and have nutrient transport structures in some embodiments. The masks may be applied to the eye in any manner and in any location, e.g., as an implant in the cornea (sometimes referred to as a "corneal inlay"). The masks can also be embodied in or combined with lenses and applied in other regions of the eye, e.g., as or in combination with contact lenses or intraocular lenses. In some applications, discussed further below, the masks are formed of a stable material, e.g., one that can be implanted permanently.

I. Overview of Pin-Hole Vision Correction

[0081] As discussed above, mask that has a pinhole aperture may be used to improve the depth of focus of a human eye. As discussed above, presbyopia is a problem of the human eye that commonly occurs in older human adults wherein the ability to focus becomes limited to inadequate range. FIGS. 1-6 illustrate how presbyopia interferes with the normal function of the eye and how a mask with a pinhole aperture mitigates the problem.

[0082] FIG. 1 shows the human eye, and FIG. 2 is a side view of the eye 10. The eye 10 includes a cornea 12 and an intraocular lens 14 posterior to the cornea 12. The cornea 12 is a first focusing element of the eye 10. The intraocular lens 14 is a second focusing element of the eye 10. The eye 10 also includes a retina 16, which lines the interior of the rear surface of the eye 10. The retina 16 includes the receptor cells which are primarily responsible for the sense of vision. The retina 16 includes a highly sensitive region, known as the macula, where signals are received and transmitted to the visual centers of the brain via the optic nerve 18. The retina 16 also includes a point with particularly high sensitivity 20, known as the fovea. As discussed in more detail in connection with FIG. 8, the fovea 20 is slightly offset from the axis of symmetry of the eye 10.

[0083] The eye 10 also includes a ring of pigmented tissue known as the iris 22. The iris 22 includes smooth muscle for controlling and regulating the size of an opening 24 in the iris 22, which is known as the pupil. An entrance pupil 26 is seen as the image of the iris 22 viewed through the cornea 12 (See FIG. 7). A central point of the entrance pupil 28 is illustrated in FIG. 7 and will be discussed further below.

[0084] The eye 10 resides in an eye-socket in the skull and is able to rotate therein about a center of rotation 30.

[0085] FIG. 3 shows the transmission of light through the eye 10 of a presbyotic patient. Due to either an aberration in the cornea 12 or the intraocular lens 14, or loss of muscle control, light rays 32 entering the eye 10 and passing through the cornea 12 and the intraocular lens 14 are refracted in such a way that the light rays 32 do not converge at a single focal point on the retina 16. FIG. 3 illustrates that in a presbyotic patient, the light rays 32 often converge at a point behind the retina 16. As a result, the patient experiences blurred vision.

[0086] Turning now to FIG. 4, there is shown the light transmission through the eye 10 to which a mask 34 has been applied. The mask 34 is shown implanted in the cornea 12 in FIG. 4. However, as discussed below, it will be understood that the mask 34 can be, in various modes of application, implanted in the cornea 12 (as shown), used as a contact lens placed over the cornea 12, incorporated in the intraocular lens 14 (including the patient's original lens or an implanted lens), or otherwise positioned on or in the eye 10. In the illustrated embodiment, the light rays 32 that pass through the mask 34, the cornea 12, and the lens 14 converge at a single focal point on the retina 16. The light rays 32 that would not converge at the single point on retina 16 are blocked by the mask 34. As discussed below, it is desirable to position the mask 34 on the eye 10 so that the light rays 32 that pass through the mask 34 converge at the fovea 20.

[0087] Turning now to FIG. 6, there is shown one embodiment of the mask 34. A variety of variations of the mask 34

are discussed hereinbelow. Section III discusses some materials that can be used to make the mask 34 and any of the variation thereof discussed hereinbelow. As seen, the mask 34 preferably includes an annular region 36 surrounding a pinhole opening or aperture 38 substantially centrally located on the mask 34. The pinhole aperture 38 is generally located around a central axis 39, referred to herein as the optical axis of the mask 34. The pinhole aperture 38 preferably is in the shape of a circle. It has been reported that a circular aperture, such as the aperture 38 may, in some patients, produce a so-called "halo effect" where the patient perceives a shimmering image around the object being viewed. Accordingly, it may be desirable to provide an aperture 38 in a shape that diminishes, reduces, or completely eliminates the so-called "halo effect."

II. Masks Employing Pin-Hole Correction

[0088] FIGS. 7-42 illustrate a variety of embodiments of masks that can improve the vision of a patient with presbyopia. The masks described in connection with FIG. 7-42 are similar to the mask 34, except as described differently below. Any of the masks discussed below, e.g., those shown in FIGS. 7-42, can be made of the materials discussed below in Section III. The mask 34 and any of the masks discussed below can include a locator structure, such as is discussed U.S. patent application Ser. No. 11/106,040, filed Apr. 14, 2005 with the title "OCULAR INLAY WITH LOCATOR" (Attorney's Docket No. ACUFO.024A), which is incorporated herein by reference in its entirety. The masks described in connection with FIGS. 7-42 can be used and applied to the eye 10 of a patient in a similar fashion to the mask 34. For example, FIG. 7 shows an embodiment of a mask 34a that includes an aperture 38a formed in the shape of a hexagon. FIG. 8 shows another embodiment of a mask 34b that includes an aperture 38b formed in the shape of an octagon. FIG. 9 shows another embodiment of a mask 34c that includes an aperture 38c formed in the shape of an oval, while FIG. 10 shows another embodiment of a mask 34d that includes an aperture 38d formed in the shape of a pointed oval. FIG. 11 shows another embodiment of a mask 34e wherein the aperture 38e is formed in the shape of a star or starburst.

[0089] FIGS. 12-14 illustrate further embodiments that have tear-drop shaped apertures. FIG. 12 shows a mask 34f that has a tear-drop shaped aperture 38f that is located above the true center of the mask 34f. FIG. 13 shows a mask 34g that has a tear-drop shaped aperture 38g that is substantially centered in the mask 34g. FIG. 14 shows a mask 34h that has a tear-drop shaped aperture 38h that is below the true center of the mask 34h. FIGS. 12-14 illustrate that the position of aperture can be tailored, e.g., centered or off-center, to provide different effects. For example, an aperture that is located below the true center of a mask generally will allow more light to enter the eye because the upper portion of the aperture 34 will not be covered by the eyelid of the patient. Conversely, where the aperture is located above the true center of the mask, the aperture may be partially covered by the eyelid. Thus, the above-center aperture may permit less light to enter the eye.

[0090] FIG. 15 shows an embodiment of a mask 34i that includes an aperture 38i formed in the shape of a square. FIG. 16 shows an embodiment of a mask 34j that has a kidney-shaped aperture 38j. It will be appreciated that the

apertures shown in **FIGS. 7-16** are merely exemplary of non-circular apertures. Other shapes and arrangements may also be provided and are within the scope of the present invention.

[0091] The mask **34** preferably has a constant thickness, as discussed below. However, in some embodiments, the thickness of the mask may vary between the inner periphery (near the aperture **38**) and the outer periphery. **FIG. 17** shows a mask **34k** that has a convex profile, i.e., that has a gradually decreasing thickness from the inner periphery to the outer periphery. **FIG. 18** shows a mask **34l** that has a concave profile, i.e., that has a gradually increasing thickness from the inner periphery to the outer periphery. Other cross-sectional profiles are also possible.

[0092] The annular region **36** is at least partially and preferably completely opaque. The opacity of the annular region **36** prevents light from being transmitted through the mask **32** (as generally shown in **FIG. 4**). Opacity of the annular region **36** may be achieved in any of several different ways.

[0093] For example, in one embodiment, the material used to make mask **34** may be naturally opaque. Alternatively, the material used to make the mask **34** may be substantially clear, but treated with a dye or other pigmentation agent to render region **36** substantially or completely opaque. In still another example, the surface of the mask **34** may be treated physically or chemically (such as by etching) to alter the refractive and transmissive properties of the mask **34** and make it less transmissive to light.

[0094] In still another alternative, the surface of the mask **34** may be treated with a particulate deposited thereon. For example, the surface of the mask **34** may be deposited with particulate of titanium, gold or carbon to provide opacity to the surface of the mask **34**. In another alternative, the particulate may be encapsulated within the interior of the mask **34**, as generally shown in **FIG. 19**. Finally, the mask **34** may be patterned to provide areas of varying light transmissivity, as generally shown in **FIGS. 24-33**, which are discussed in detail below.

[0095] Turning to **FIG. 20**, there is shown a mask **34m** formed or made of a woven fabric, such as a mesh of polyester fibers. The mesh may be a cross-hatched mesh of fibers. The mask **34m** includes an annular region **36m** surrounding an aperture **38m**. The annular region **36m** comprises a plurality of generally regularly positioned apertures **36m** in the woven fabric allow some light to pass through the mask **34m**. The amount of light transmitted can be varied and controlled by, for example, moving the fibers closer together or farther apart, as desired. Fibers more densely distributed allow less light to pass through the annular region **36m**. Alternatively, the thickness of fibers can be varied to allow more or less light through the openings of the mesh. Making the fiber strands larger results in the openings being smaller.

[0096] **FIG. 22** shows an embodiment of a mask **34n** that includes an annular region **36n** that has sub-regions with different opacities. The opacity of the annular region **36n** may gradually and progressively increase or decrease, as desired. **FIG. 22** shows one embodiment where a first area **42** closest to an aperture **38n** has an opacity of approximately 43%. In this embodiment, a second area **44**, which is

outlying with respect to the first area **42**, has a greater opacity, such as 70%. In this embodiment, a third area **46**, which is outlying with respect to the second area **42**, has an opacity of between 85 to 100%. The graduated opacity of the type described above and shown in **FIG. 22** is achieved in one embodiment by, for example, providing different degrees of pigmentation to the areas **42**, **44** and **46** of the mask **34n**. In another embodiment, light blocking materials of the type described above in variable degrees may be selectively deposited on the surface of a mask to achieve a graduated opacity.

[0097] In another embodiment, the mask may be formed from co-extruded rods made of material having different light transmissive properties. The co-extruded rod may then be sliced to provide disks for a plurality of masks, such as those described herein.

[0098] **FIGS. 24-33** shows examples of masks that have been modified to provide regions of differing opacity. For example, **FIG. 24** shows a mask **34o** that includes an aperture **38o** and a plurality of cutouts **48** in the pattern of radial spokes extending from near the aperture **38o** to an outer periphery **50** of the mask **34o**. **FIG. 24** shows that the cutouts **48** are much more densely distributed about a circumference of the mask near aperture **38o** than are the cutouts **48** about a circumference of the mask near the outer periphery **50**. Accordingly, more light passes through the mask **34o** nearer aperture **38o** than near the periphery **50**. The change in light transmission through the mask **34o** is gradual.

[0099] **FIGS. 26-27** show another embodiment of a mask **34p**. The mask **34p** includes an aperture **38p** and a plurality of circular cutouts **49p**, and a plurality of cutouts **51p**. The circular cutouts **49p** are located proximate the aperture **38p**. The cutouts **51p** are located between the circular cutouts **49p** and the periphery **50p**. The density of the circular cutouts **49p** generally decreases from the near the aperture **38p** toward the periphery **50p**. The periphery **50p** of the mask **34p** is scalloped by the presence of the cutouts **51**, which extend inward from the periphery **50p**, to allow some light to pass through the mask at the periphery **50p**.

[0100] **FIGS. 28-29** shows another embodiment similar to that of **FIGS. 26-27** wherein a mask **34q** includes a plurality of circular cutouts **49q** and a plurality of cutouts **51q**. The cutouts **51q** are disposed along the outside periphery **50q** of the mask **34q**, but not so as to provide a scalloped periphery.

[0101] **FIGS. 30 and 31** illustrate an embodiment of a mask **34r** that includes an annular region **36r** that is patterned and an aperture **38r** that is non-circular. As shown in **FIG. 30**, the aperture **38r** is in the shape of a starburst. Surrounding the aperture **38r** is a series of cutouts **51r** that are more densely spaced toward the aperture **38r**. The mask **34r** includes an outer periphery **50r** that is scalloped to provide additional light transmission at the outer periphery **50r**.

[0102] **FIGS. 32 and 33** show another embodiment of a mask **34s** that includes an annular region **36s** and an aperture **38s**. The annular region **36s** is located between an outer periphery **50s** of the mask **34s** and the aperture **38s**. The annular region **36s** is patterned. In particular, a plurality of circular openings **56s** is distributed over the annular region **36s** of the mask **34s**. It will be appreciated that the density

of the openings **56s** is greater near the aperture **38s** than near the periphery **50s** of the mask **34s**. As with the examples described above, this results in a gradual increase in the opacity of the mask **34s** from aperture **38s** to periphery **50s**.

[0103] FIGS. **34-36** show further embodiments. In particular, FIG. **34** shows a mask **34t** that includes a first mask portion **58t** and a second mask portion **43t**. The mask portions **58t**, **43t** are generally "C-shaped." As shown in FIG. **34**, the mask portions **58t**, **43t** are implanted or inserted such that the mask portions **58t**, **43t** define a pinhole or aperture **38t**.

[0104] FIG. **35** shows another embodiment wherein a mask **34u** includes two mask portions **58u**, **43u**. Each mask portion **58u**, **43u** is in the shape of a half-moon and is configured to be implanted or inserted in such a way that the two halves define a central gap or opening **45u**, which permits light to pass therethrough. Although opening **45u** is not a circular pinhole, the mask portions **58u**, **43u** in combination with the eyelid (shown as dashed line **47**) of the patient provide a comparable pinhole effect.

[0105] FIG. **36** shows another embodiment of a mask **34v** that includes an aperture **38v** and that is in the shape of a half-moon. As discussed in more detail below, the mask **34v** may be implanted or inserted into a lower portion of the cornea **12** where, as described above, the combination of the mask **34v** and the eyelid **45** provides the pinhole effect.

[0106] Other embodiments employ different ways of controlling the light transmissivity through a mask. For example, the mask may be a gel-filled disk, as shown in FIG. **19**. The gel may be a hydrogel or collagen, or other suitable material that is biocompatible with the mask material and can be introduced into the interior of the mask. The gel within the mask may include particulate **53** suspended within the gel. Examples of suitable particulate are gold, titanium, and carbon particulate, which, as discussed above, may alternatively be deposited on the surface of the mask.

[0107] The material of the mask **34** may be any biocompatible polymeric material. Where a gel is used, the material is suitable for holding a gel. Examples of suitable materials for the mask **34** include the preferred polymethylmethacrylate or other suitable polymers, such as polycarbonates and the like. Of course, as indicated above, for non-gel-filled materials, a preferred material may be a fibrous material, such as a Dacron mesh.

[0108] The mask **34** may also be made to include a medicinal fluid or material, such as an antibiotic or other wound healing modulator that can be selectively released after application, insertion, or implantation of the mask **34** into the eye of the patient. Release of an antibiotic or other wound healing modulator after application, insertion, or implantation provides faster and/or improved healing of the incision. The mask **34** may also be coated with other desired drugs or antibiotics. For example, it is known that cholesterol deposits can build up on the eye. Accordingly, the mask **34** may be provided with a releasable cholesterol deterring drug. The drug may be coated on the surface of the mask **34** or, in an alternative embodiment, incorporated into the polymeric material (such as PMMA) from which the mask **34** is formed.

[0109] FIGS. **37 and 38** illustrate one embodiment where a mask **34w** comprises a plurality of nanites **68**. "Nanites"

are small particulate structures that have been adapted to selectively transmit or block light entering the eye of the patient. The particles may be of a very small size typical of the particles used in nanotechnology applications. The nanites **68** are suspended in the gel or otherwise inserted into the interior of the mask **34w**, as generally shown in FIGS. **37 and 38**. The nanites **68** can be preprogrammed to respond to different light environments.

[0110] Thus, as shown in FIG. **37**, in a high light environment, the nanites **68** turn and position themselves to substantially and selectively block some of the light from entering the eye. However, in a low light environment where it is desirable for more light to enter the eye, nanites may respond by turning or be otherwise positioned to allow more light to enter the eye, as shown in FIG. **38**.

[0111] Nano-devices or nanites are crystalline structures grown in laboratories. The nanites may be treated such that they are receptive to different stimuli such as light. In accordance with one aspect of the present invention, the nanites can be imparted with energy where, in response to a low light and high light environments, they rotate in the manner described above and generally shown in FIG. **38**.

[0112] Nanoscale devices and systems and their fabrication are described in Smith et al., "Nanofabrication," Physics Today, February 1990, pp. 24-30 and in Craighead, "Nanoelectromechanical Systems," Science, Nov. 24, 2000, Vol. 290, pp. 1502-1505, both of which are incorporated by reference herein in their entirety. Tailoring the properties of small-sized particles for optical applications is disclosed in Chen et al. "Diffractive Phase Elements Based on Two-Dimensional Artificial Dielectrics," Optics Letters, Jan. 15, 1995, Vol. 20, No. 2, pp. 121-123, also incorporated by reference herein in its entirety.

[0113] Masks **34** made in accordance with the present invention may be further modified to include other properties. FIG. **39** shows one embodiment of a mask **34x** that includes a bar code **70** or other printed indicia.

[0114] The masks described herein may be incorporated into the eye of a patient in different ways. For example, as discussed in more detail below in connection with FIG. **49**, the mask **34** may be provided as a contact lens placed on the surface of the eyeball **10**. Alternatively, the mask **34** may be incorporated in an artificial intraocular lens designed to replace the original lens **14** of the patient. Preferably, however, the mask **34** is provided as a corneal implant or inlay, where it is physically inserted between the layers of the cornea **12**.

[0115] When used as a corneal implant, layers of the cornea **12** are peeled away to allow insertion of the mask **34**. Typically, the optical surgeon (using a laser) cuts away and peels away a flap of the overlying corneal epithelium. The mask **34** is then inserted and the flap is placed back in its original position where, over time, it grows back and seals the eyeball. In some embodiments, the mask **34** is attached or fixed to the eye **10** by support strands **72** and **74** shown in FIG. **40** and generally described in U.S. Pat. No. 4,976,732, incorporated by reference herein in its entirety.

[0116] In certain circumstances, to accommodate the mask **34**, the surgeon may be required to remove additional corneal tissue. Thus, in one embodiment, the surgeon may use a laser to peel away additional layers of the cornea **12** to

provide a pocket that will accommodate the mask **34**. Application of the mask **34** to the cornea **12** of the eye **10** of a patient is described in greater detail in connection with **FIGS. 50A-51C**.

[0117] Removal of the mask **34** may be achieved by simply making an additional incision in the cornea **12**, lifting the flap and removing the mask **34**. Alternatively, ablation techniques may be used to completely remove the mask **34**.

[0118] **FIGS. 41 and 42** illustrate another embodiment, of a mask **34y** that includes a coiled strand **80** of a fibrous or other material. Strand **80** is coiled over itself to form the mask **34y**, which may therefore be described as a spiral-like mask. This arrangement provides a pinhole or aperture **38y** substantially in the center of the mask **34y**. The mask **34y** can be removed by a technician or surgeon who grasps the strand **80** with tweezers **82** through an opening made in a flap of the corneal **12**. **FIG. 42** shows this removal technique.

[0119] Further mask details are disclosed in U.S. Pat. No. 4,976,732, issued Dec. 11, 1990 and in U.S. patent application Ser. No. 10/854,033, filed May 26, 2004, both of which are incorporated by reference herein in their entirety.

III. Preferred UV-Resistant Polymeric Mask Materials

[0120] Because the mask has a very high surface to volume ratio and is exposed to a great deal of sunlight following implantation, the mask preferably comprises a material which has good resistance to degradation, including from exposure to ultraviolet (UV) or other wavelengths of light. Polymers including a UV absorbing component, including those comprising UV absorbing additives or made with UV absorbing monomers (including co-monomers), may be used in forming masks as disclosed herein which are resistant to degradation by UV radiation. Examples of such polymers include, but are not limited to, those described in U.S. Pat. Nos. 4,985,559 and 4,528,311, the disclosures of which are hereby incorporated by reference in their entireties. In a preferred embodiment, the mask comprises a material which itself is resistant to degradation by UV radiation. In one embodiment, the mask comprises a polymeric material which is substantially reflective of or transparent to UV radiation.

[0121] Alternatively, the mask may include a component which imparts a degradation resistive effect, or may be provided with a coating, preferably at least on the anterior surface, which imparts degradation resistance. Such components may be included, for example, by blending one or more degradation resistant polymers with one or more other polymers. Such blends may also comprise additives which provide desirable properties, such as UV absorbing materials. In one embodiment, blends preferably comprise a total of about 1-20 wt. %, including about 1-10 wt. %, 5-15 wt. %, and 10-20 wt. % of one or more degradation resistant polymers. In another embodiment, blends preferably comprise a total of about 80-100 wt. %, including about 80-90 wt. %, 85-95 wt. %, and 90-100 wt. % of one or more degradation resistant polymers. In another embodiment, the blend has more equivalent proportions of materials, comprising a total of about 40-60 wt. %, including about 50-60 wt. %, and 40-50 wt. % of one or more degradation resistant polymers. Masks may also include blends of different types of degradation resistant polymers, including those blends comprising one or more generally UV transparent or reflec-

tive polymers with one or more polymers incorporating UV absorption additives or monomers. These blends include those having a total of about 1-20 wt. %, including about 1-10 wt. %, 5-15 wt. %, and 10-20 wt. % of one or more generally UV transparent polymers, a total of about 80-100 wt. %, including about 80-90 wt. %, 85-95 wt. %, and 90-100 wt. % of one or more generally UV transparent polymers, and a total of about 40-60 wt. %, including about 50-60 wt. %, and 40-50 wt. % of one or more generally UV transparent polymers. The polymer or polymer blend may be mixed with other materials as discussed below, including, but not limited to, opacification agents, polyanionic compounds and/or wound healing modulator compounds. When mixed with these other materials, the amount of polymer or polymer blend in the material which makes up the mask is preferably about 50%-99% by weight, including about 60%-90% by weight, about 65-85% by weight, about 70-80% by weight, and about 90-99% by weight.

[0122] Preferred degradation resistant polymers include halogenated polymers. Preferred halogenated polymers include fluorinated polymers, that is, polymers having at least one carbon-fluorine bond, including highly fluorinated polymers. The term "highly fluorinated" as it is used herein, is a broad term used in its ordinary sense, and includes polymers having at least one carbon-fluorine bond (C—F bond) where the number of C—F bonds equals or exceeds the number of carbon-hydrogen bonds (C—H bonds). Highly fluorinated materials also include perfluorinated or fully fluorinated materials, materials which include other halogen substituents such as chlorine, and materials which include oxygen- or nitrogen-containing functional groups. For polymeric materials, the number of bonds may be counted by referring to the monomer(s) or repeating units which form the polymer, and in the case of a copolymer, by the relative amounts of each monomer (on a molar basis).

[0123] Preferred highly fluorinated polymers include, but are not limited to, polytetrafluoroethylene (PTFE or Teflon®), polyvinylidene fluoride (PVDF or Kynar®), poly-1,1,2-trifluoroethylene, and perfluoroalkoxyethylene (PFA). Other highly fluorinated polymers include, but are not limited to, homopolymers and copolymers including one or more of the following monomer units: tetrafluoroethylene —(CF₂—CF₂)—; vinylidene fluoride —(CF₂—CH₂)—; 1,1,2-trifluoroethylene —(CF₂—CHF)—; hexafluoropropene —(CF(CF₃)—CF₂)—; vinyl fluoride —(CH₂—CHF)— (homopolymer is not "highly fluorinated"); oxygen-containing monomers such as —(O—CF₂)—, —(O—CF₂—CF₂)—, —(O—CF(CF₃)—CF₂)—; chlorine-containing monomers such as —(CF₂—CFCl)—. Other fluorinated polymers, such as fluorinated polyimide and fluorinated acrylates, having sufficient degrees of fluorination are also contemplated as highly fluorinated polymers for use in masks according to preferred embodiments. The homopolymers and copolymers described herein are available commercially and/or methods for their preparation from commercially available materials are widely published and known to those in the polymer arts.

[0124] Although highly fluorinated polymers are preferred, polymers having one or more carbon-fluorine bonds but not falling within the definition of "highly fluorinated" polymers as discussed above, may also be used. Such polymers include co-polymers formed from one or more of the monomers in the preceding paragraph with ethylene,

vinyl fluoride or other monomer to form a polymeric material having a greater number of C—H bonds than C—F bonds. Other fluorinated polymers, such as fluorinated polyimide, may also be used. Other materials that could be used in some applications, alone or in combination with a fluorinated or a highly fluorinated polymer, are described in U.S. Pat. No. 4,985,559 and in U.S. Pat. No. 4,538,311, both of which are hereby incorporated by reference herein in their entirety.

[0125] The preceding definition of highly fluorinated is best illustrated by means of a few examples. One preferred UV-resistant polymeric material is polyvinylidene fluoride (PVDF), having a structure represented by the formula: $-(CF_2-CH_2)_n-$. Each repeating unit has two C—H bonds, and two C—F bonds. Because the number of C—F bonds equals or exceeds the number of C—H bonds, PVDF homopolymer is a “highly fluorinated” polymer. Another material is a tetrafluoroethylene/vinyl fluoride copolymer formed from these two monomers in a 2:1 molar ratio. Regardless of whether the copolymer formed is block, random or any other arrangement, from the 2:1 tetrafluoroethylene:vinyl fluoride composition one can presume a “repeating unit” comprising two tetrafluoroethylene units, each having four C—F bonds, and one vinyl fluoride unit having three C—H bonds and one C—F bond. The total bonds for two tetrafluoroethylenes and one vinyl fluoride are nine C—F bonds, and three C—H bonds. Because the number of C—F bonds equals or exceeds the number of C—H bonds, this copolymer is considered highly fluorinated.

[0126] Certain highly fluorinated polymers, such as PVDF, have one or more desirable characteristics, such as being relatively chemically inert and having a relatively high UV transparency as compared to their non-fluorinated or less highly fluorinated counterpart polymers. Although the applicant does not intend to be bound by theory, it is postulated that the electronegativity of fluorine may be responsible for many of the desirable properties of the materials having relatively large numbers of C—F bonds.

[0127] In preferred embodiments, at least a portion of the highly fluorinated polymer material forming the mask comprises an opacification agent which imparts a desired degree of opacity. In one embodiment, the opacification agent provides sufficient opacity to produce the depth of field improvements described herein, e.g., in combination with a transmissive aperture. In one embodiment, the opacification agent renders the material opaque. In another embodiment, the opacification agent prevents transmission of about 90 percent or more of incident light. In another embodiment, the opacification agent renders the material opaque. In another embodiment, the opacification agent prevents transmission of about 80 percent or more of incident light. Preferred opacification agents include, but are not limited to organic dyes and/or pigments, preferably black ones, such as azo dyes, hematoxylin black, and Sudan black; inorganic dyes and/or pigments, including metal oxides such as iron oxide black and ilmenite, silicon carbide and carbon (e.g. carbon black, submicron powdered carbon). The foregoing materials may be used alone or in combination with one or more other materials. The opacification agent may be applied to one or more surfaces of the mask on all or some of the surface, or it may be mixed or combined with the polymeric material (e.g. blended during the polymer melt

phase). Although any of the foregoing materials may be used, carbon has been found to be especially useful in that it does not fade over time as do many organic dyes, and that it also aids the UV stability of the material by absorbing UV radiation. In one embodiment, carbon may be mixed with polyvinylidene fluoride (PVDF) or other polymer composition comprising highly fluorinated polymer such that the carbon comprises about 2% to about 20% by weight of the resulting composition, including about 10% to about 15% by weight, including about 12%, about 13%, and about 14% by weight of the resulting composition.

[0128] Some opacification agents, such as pigments, which are added to blacken, darken or opacify portions of the mask may cause the mask to absorb incident radiation to a greater degree than mask material not including such agents. Because the matrix polymer that carries or includes the pigments may be subject to degradation from the absorbed radiation, it is preferred that the mask, which is thin and has a high surface area making it vulnerable to environmental degradation, be made of a material which is itself resistant to degradation such as from UV radiation, or that it be generally transparent to or non-absorbing of UV radiation. Use of a highly UV resistant and degradation resistant material, such as PVDF, which is highly transparent to UV radiation, allows for greater flexibility in choice of opacification agent because possible damage to the polymer caused by selection of a particular opacification agent is greatly reduced.

[0129] A number of variations of the foregoing embodiments of degradation resistant constructions are contemplated. In one variation, a mask is made almost exclusively of a material that is not subject to UV degradation. For example, the mask can be made of a metal, a highly fluorinated polymer, or another similar material. Construction of the mask with metal is discussed in more detail in U.S. application Ser. No. 11/000,562 filed Dec. 1, 2004 and entitled “Method of Making an Ocular Implant” and also in U.S. application Ser. No. 11/107,359 filed Apr. 14, 2005 with the title “Method of Making an Ocular Implant”, both of which are incorporated herein in their entirety by reference. As used in this context, “exclusively” is a broad term that allows for the presence of some non-functional materials (e.g., impurities) and for an opacification agent, as discussed above. In other embodiments, the mask can include a combination of materials. For example, in one variation, the mask is formed primarily of any implantable material and is coated with a UV resistant material. In another variation, the mask includes one or more UV degradation inhibitors and/or one or more UV degradation resistant polymers in sufficient concentration such that the mask under normal use conditions will maintain sufficient functionality in terms of degradation to remain medically effective for at least about 5 years, preferably at least about 10 years, and in certain implementations at least about 20 years.

[0130] FIG. 54 is a flow chart illustrating one method for making a mask from a composition comprising a highly fluorinated polymer and an opacification agent. At step 2000, a liquid form of a polymer is created by dissolving polyvinylidene fluoride (PVDF) pellets into a solvent such as Dimethyl Acetamide (DMAC or DMA) using heat until the PVDF has completely dissolved. In one embodiment, the solution may be mixed for a minimum of 12 hours to ensure

that the PVDF has completely dissolved. At step **2200**, the PVDF/DMAC solution is mixed with an opacification agent, such as carbon black, using a high speed shear mixer. In one embodiment, the carbon black comprises 13% by weight of the resulting composition while the PVDF comprises 87% by weight of the resulting composition. At step **2300**, the PVDF/carbon black solution is milled in a high speed mill, for example an Eiger high speed mill, to break up any large carbon agglomerates in the solution. The PVDF/carbon black solution may be run through the mill a second time to further break up any carbon agglomerates. At step **2400**, the resulting solution is applied to a silicone wafer to create a polymer film on the silicone disk. Here, approximately 55 g of the PVDF/carbon black solution is poured into a dispensing barrel for application on a silicone wafer. The silicone disk is placed on the spinner of a spin casting machine and the dispensing barrel is used to apply a bead of PVDF/carbon black solution to the silicone wafer in a circular pattern, leaving the center 1" diameter of the disk empty. The spinner cycle is actuated to disperse the PVDF/carbon black solution over the disk, forming a uniform 10 micron thick film. The coated silicone disk is then placed on a hot-plate to evaporate the DMAC. At step **2500**, the coated silicon e wafer is placed under an Eximer laser. A laser cutting mask is mounted in the laser and the laser is actuated. Using the laser cutting mask, approximately 150 corneal mask patterns are laser machined into the PVDF/carbon black film. The corneal mask patterns are arranged such that the material extending approximately 5 mm from the edge of the silicon disk is not used. During the laser machining, the silicone disk may be bathed in Nitrogen gas in order to cool the surface. At step **2600**, the laser machined masks are removed from the silicone disk using a razor blade and placed into the bottom half of a convex Teflon forming mold. The top half of the Teflon forming mold is placed on top of the mask and the molds placed in an oven at about 160° C. At step **2700**, the molds are heated and baked to cure the masks. The molds are allowed to bake for approximately two hours at approximately 160° C. After two hours the oven temperature is reduced to about 30° C. and the masks are baked for approximately two hours or until the oven temperature has dropped to below around 40° C.

IV. Additives to Reduce Corneal Deposits and/or Promote Proper Healing

[0131] In some circumstances, corneal implants are associated with deposits on the cornea. Loading of one or more polyanionic compounds into the polymeric material of a corneal implant may reduce and/or substantially eliminate deposits on the cornea, possibly by attracting and/or retaining growth factors.

[0132] In a preferred embodiment the one or more polyanionic compounds include carbohydrates, proteins, natural proteoglycans, and/or the glycosaminoglycan moieties of proteoglycans, as well as derivatives (such as sulfated derivatives) and salts of compounds such as those in the aforementioned categories. Preferred polyanionic compounds include one or more of dermatan sulfate, chondroitin sulfate, keratan sulfate, heparan sulfate, heparin, dextran sulfate, hyaluronic acid, protosan polysulfate, xanthan, carrageenan, fibronectin, laminin, chondronectin, vitronectin, poly L-lysine salts, and anionic, preferably sulfated, carbohydrates such as alginate may also be used, as well as salts and derivatives of the listed compounds. Examples of pre-

ferred anionic compounds and combinations of polyanionic compounds include keratan sulfate/chondroitin sulfate-proteoglycan, dermatan sulfate proteoglycan, and dextran sulfate.

[0133] In one embodiment, a polyanionic compound comprises acidic sulfate moieties and the sulfur content is greater than about 5% by weight, preferably greater than about 10% by weight. In an even more preferred embodiment, the average molecular weight of a polyanionic compound is about 40,000 to 500,000 Daltons.

[0134] In a preferred embodiment, the total weight of the one or more polyanionic compounds in the loaded polymeric material is about 0.1% by weight to about 50% by weight, including about 5% by weight to about 20% by weight, about 12% by weight to about 17% by weight, about 0.5% by weight to about 4% by weight, and about 5% by weight to about 15% by weight. It should be noted that the percentages recited herein in relation to polyanionic compounds, opacification agents and wound healing modulator compounds are percent by weight with 100% being the total weight of the entire mask composition including all additives.

[0135] In one embodiment, the body of the mask is formed from a polymeric material having one or more polyanionic compounds loaded therein. Loading of a polyanionic compound is performed by mixing the polyanionic compound with the resin and any other additives of the polymeric material prior to molding or casting of the body of the mask. Although some of a polyanionic compound that is loaded into the polymeric material may be on the surface of the mask, loading is to be distinguished from coating in that a coated material would not have polyanionic material throughout the bulk of the mask.

[0136] The loaded polymeric material is preferably made by suspending or dissolving polymer, one or more polyanionic compounds and any other additives (such as wound healing modulators, as described below) in a solvent or solvent system, and then casting a film whereby the solvent or solvent system is removed such as by evaporation. Preferred casting methods include spin casting and other methods, including those known in the art, which can form a thin material of relatively even thickness. Although other methods of making thin substrates, such as extrusion, may be used, solvent casting is generally preferred because it does not need to be done at high temperatures that may cause degradation of some polyanionic compounds. The polymer, polyanionic compound, and/or other additives may be ground or milled, such as by ball milling, to reduce the particle size of the material prior to suspending, dissolving or melting as part of making the mask.

[0137] In methods using solvent casting, preferred solvents include those which are capable of dissolving the polymeric material, polyanionic compounds, and/or other additives. A suitable solvent or solvent system (i.e. combination of two or more solvents) may be chosen by one skilled in the art based upon known solubilities for a given polymeric material and/or routine experimentation based upon chemical principles. In solvent casting methods, the temperature of the solvent or solution should be no higher than the boiling point of the solvent or solvent system, and is preferably about 10° C. to about 70° C. During or after casting of the solution to form a film, the temperature may be elevated, including above the boiling point.

[0138] In one embodiment, a mask, such as an inlay, comprising PVDF, dextran sulfate, and carbon was made by spin casting. 100 grams of PVDC (about 71% by weight) in the form of pellets was dissolved in 400 grams of dimethylacetamide. 17 grams of carbon (about 12% by weight) and 24 grams of dextran sulfate (about 17% by weight) are ball milled to reduce particle size and then added to the PVDF/DMA solution. The percentages by weight are the percentages of the solids portion, that is the portion that is not the solvent. The solution was at room temperature (approximately 17° C. to about 25° C.). The solution was then spin cast to form a film.

[0139] In one embodiment, the device includes a wound healing modulator. When present, the wound healing modulator is on at least one surface or it may be loaded into the polymeric material. A wound healing modulator is defined as a compound that assists in proper healing of a wound, such as by increasing the rate of healing, decreasing inflammation, moderating or suppressing immune response, decreasing scarring, decreasing cell proliferation, reducing infection, encouraging transdifferentiation of keratocytes into cells that lay down collagen, and the like. Wound healing modulators include, without limitation, antibiotics, antineoplastics including antimetotics, antimetabolics and antibiotic types, anti-inflammatory, immunosuppressants, and antifungals. Preferred compounds include, but are not limited to, fluorouracil, mitomycin C, paclitaxel, NSAIDs (e.g. ibuprofen, naproxen, flurbiprofen, carprofen, suprofen, ketoprofen), and cyclosporins. Other preferred compounds include proteoglycans, glycosaminoglycans, and salts and derivatives thereof, as well as other carbohydrates and/or proteins, including those disclosed above.

[0140] A wound healing modulator may be included in the mask by loading it into the polymeric material as discussed above with respect to the polyanionic compounds. It may also be included by binding it to one or more surfaces of the device. The "binding" of the wound healing modulator to the device may occur by phenomena that do not generally involve chemical bonds, including adsorption, hydrogen bonding, van der Waals forces, electrostatic attraction, ionic bonding, and the like, or it may occur by phenomena that do include chemical bonds. In a preferred embodiment, the total weight of the one or more wound healing modulator compounds in the loaded polymeric material is about 0.1% by weight to about 50% by weight, including about 5% by weight to about 20% by weight, about 12% by weight to about 17% by weight, about 0.5% by weight to about 4% by weight, and about 5% by weight to about 15% by weight.

[0141] In one embodiment, carbon, gold or other material on a surface of the mask acts as an adsorbent or otherwise participates in the binding of one or more wound healing modulators to the implant. The material on the surface of the mask that participates in binding the wound healing modulator may be part of the bulk material of the implant (distributed throughout the implant or which migrates to the surface during and/or following formation of the implant) and/or deposited on a surface of the mask, such as an opacification agent as described elsewhere *infra*. The implant is then exposed to one or more wound healing modulators, such as by dipping in a solution (including dispersions and emulsions) comprising at least one wound healing modulator, to allow wound healing modulator(s) to bind to the implant. The solvent used to assist in applying

and binding the wound healing modulator to the implant is preferably biocompatible, does not leave a harmful residue, and/or does not cause dissolution or swelling of the polymeric material of the mask. If more than one wound healing modulator is used, binding may be performed by dipping in a single solution containing all desired wound healing modulators or by dipping the implant in two or more successive solutions, each of which contains one or more of the desired wound healing modulators. The process of binding wound healing modulator to the implant may be done at any time. In one embodiment, at least some of the wound healing modulator is bound to the implant as part of the manufacturing process. In another embodiment, a medical practitioner, such as an ophthalmologist, binds at least some of the wound healing modulator to the implant just prior to implantation.

[0142] In alternate embodiments, one or more wound healing modulators are bound to the implant using any suitable method for binding drugs or other useful compounds to implants and medical devices and/or using methods for making drug delivery devices which deliver a drug locally in the area of implantation or placement over a period of time.

V. Masks Configured to Reduce Visible Diffraction Patterns

[0143] Many of the foregoing masks can be used to improve the depth of focus of a patient. Various additional mask embodiments are discussed below. Some of the embodiments described below include nutrient transport structures that are configured to enhance or maintain nutrient flow between adjacent tissues by facilitating transport of nutrients across the mask. The nutrient transport structures of some of the embodiments described below are configured to at least substantially prevent nutrient depletion in adjacent tissues. The nutrient transport structures can decrease negative effects due to the presence of the mask in adjacent corneal layers when the mask is implanted in the cornea, increasing the longevity of the masks. The inventors have discovered that certain arrangements of nutrient transport structures generate diffraction patterns that interfere with the vision improving effect of the masks described herein. Accordingly, certain masks are described herein that include nutrient transport structures that do not generate diffraction patterns or otherwise interfere with the vision enhancing effects of the mask embodiments.

[0144] FIGS. 43-44 show one embodiment of a mask **100** configured to increase depth of focus of an eye of a patient suffering from presbyopia. The mask **100** is similar to the masks hereinbefore described, except as described differently below. The mask **100** can be made of the materials discussed herein, including those discussed in Section III. Also, the mask **100** can be formed by any suitable process, such as those discussed below in connection with FIGS. 48a-48d with variations of such processes. The mask **100** is configured to be applied to an eye of a patient, e.g., by being implanted in the cornea of the patient. The mask **100** may be implanted within the cornea in any suitable manner, such as those discussed above in connection with FIGS. 50A-51C.

[0145] In one embodiment, the mask **100** includes a body **104** that has an anterior surface **108** and a posterior surface **112**. In one embodiment, the body **104** is capable of substantially maintaining natural nutrient flow between the first corneal layer and the second corneal layer. In one embodi-

ment, the material is selected to maintain at least about ninety-six percent of the natural flow of at least one nutrient (e.g., glucose) between a first corneal layer (e.g., the layer 1210) and a second corneal layer (e.g., the layer 1220). The body 104 may be formed of any suitable material, including at least one of an open cell foam material, an expanded solid material, and a substantially opaque material. In one embodiment, the material used to form the body 104 has relatively high water content.

[0146] In one embodiment, the mask 100 includes and a nutrient transport structure 116. The nutrient transport structure 116 may comprise a plurality of holes 120. The holes 120 are shown on only a portion of the mask 100, but the holes 120 preferably are located throughout the body 104 in one embodiment. In one embodiment, the holes 120 are arranged in a hex pattern, which is illustrated by a plurality of locations 120' in FIG. 45A. As discussed below, a plurality of locations may be defined and later used in the later formation of a plurality of holes 120 on the mask 100. The mask 100 has an outer periphery 124 that defines an outer edge of the body 104. In some embodiments, the mask 100 includes an aperture 128 at least partially surrounded by the outer periphery 124 and a non-transmissive portion 132 located between the outer periphery 124 and the aperture 128.

[0147] Preferably the mask 100 is symmetrical, e.g., symmetrical about a mask axis 136. In one embodiment, the outer periphery 124 of the mask 100 is circular. The masks in general have a diameter within the range of from about 3 mm to about 8 mm, often within the range of from about 3.5 mm to about 6 mm, and less than about 6 mm in one embodiment. In another embodiment, the mask is circular and has a diameter in the range of 4 to 6 mm. In another embodiment, the mask 100 is circular and has a diameter of less than 4 mm. The outer periphery 124 has a diameter of about 3.8 mm in another embodiment. In some embodiments, masks that are asymmetrical or that are not symmetrical about a mask axis provide benefits, such as enabling a mask to be located or maintained in a selected position with respect to the anatomy of the eye.

[0148] The body 104 of the mask 100 may be configured to coupled with a particular anatomical region of the eye. The body 104 of the mask 100 may be configured to conform to the native anatomy of the region of the eye in which it is to be applied. For example, where the mask 100 is to be coupled with an ocular structure that has curvature, the body 104 may be provided with an amount of curvature along the mask axis 136 that corresponds to the anatomical curvature. For example, one environment in which the mask 100 may be deployed is within the cornea of the eye of a patient. The cornea has an amount of curvature that varies from person to person about a substantially constant mean value within an identifiable group, e.g., adults. When applying the mask 100 within the cornea, at least one of the anterior and posterior surfaces 108, 112 of the mask 100 may be provided with an amount of curvature corresponding to that of the layers of the cornea between which the mask 100 is applied.

[0149] In some embodiments, the mask 100 has a desired amount of optical power. Optical power may be provided by configuring the at least one of the anterior and posterior surfaces 108, 112 with curvature. In one embodiment, the

anterior and posterior surfaces 108, 112 are provided with different amounts of curvature. In this embodiment, the mask 100 has varying thickness from the outer periphery 124 to the aperture 128.

[0150] In one embodiment, one of the anterior surface 108 and the posterior surface 112 of the body 104 is substantially planar. In one planar embodiment, very little or no uniform curvature can be measured across the planar surface. In another embodiment, both of the anterior and posterior surfaces 108, 112 are substantially planar. In general, the thickness of the inlay may be within the range of from about 1 micron to about 40 micron, and often in the range of from about 5 micron to about 20 micron. In one embodiment, the body 104 of the mask 100 has a thickness 138 of between about 5 micron and about 10 micron. In one embodiment, the thickness 138 of the mask 100 is about 5 micron. In another embodiment, the thickness 138 of the mask 100 is about 8 micron. In another embodiment, the thickness 138 of the mask 100 is about 10 micron.

[0151] Thinner masks generally are more suitable for applications wherein the mask 100 is implanted at a relatively shallow location in (e.g., close to the anterior surface of) the cornea. In thinner masks, the body 104 may be sufficiently flexible such that it can take on the curvature of the structures with which it is coupled without negatively affecting the optical performance of the mask 100. In one application, the mask 100 is configured to be implanted about 5 um beneath the anterior surface of the cornea. In another application, the mask 100 is configured to be implanted about 52 um beneath the anterior surface of the cornea. In another application, the mask 100 is configured to be implanted about 125 um beneath the anterior surface of the cornea. Further details regarding implanting the mask 100 in the cornea are discussed above in connection with FIGS. 50A-51C.

[0152] A substantially planar mask has several advantages over a non-planar mask. For example, a substantially planar mask can be fabricated more easily than one that has to be formed to a particular curvature. In particular, the process steps involved in inducing curvature in the mask 100 can be eliminated. Also, a substantially planar mask may be more amenable to use on a wider distribution of the patient population (or among different sub-groups of a broader patient population) because the substantially planar mask uses the curvature of each patient's cornea to induce the appropriate amount of curvature in the body 104.

[0153] In some embodiments, the mask 100 is configured specifically for the manner and location of coupling with the eye. In particular, the mask 100 may be larger if applied over the eye as a contact lens or may be smaller if applied within the eye posterior of the cornea, e.g., proximate a surface of the lens of the eye. As discussed above, the thickness 138 of the body 104 of the mask 100 may be varied based on where the mask 100 is implanted. For implantation at deeper levels within the cornea, a thicker mask may be advantageous. Thicker masks are advantageous in some applications. For example, they are generally easier to handle, and therefore are easier to fabricate and to implant. Thicker masks may benefit more from having a preformed curvature than thinner masks. A thicker mask could be configured to have little or no curvature prior to implantation if it is configured to conform to the curvature of the native anatomy when applied.

[0154] The aperture 128 is configured to transmit substantially all incident light along the mask axis 136. The non-transmissive portion 132 surrounds at least a portion of the aperture 128 and substantially prevents transmission of incident light thereon. As discussed in connection with the above masks, the aperture 128 may be a through-hole in the body 104 or a substantially light transmissive (e.g., transparent) portion thereof. The aperture 128 of the mask 100 generally is defined within the outer periphery 124 of the mask 100. The aperture 128 may take any of suitable configurations, such as those described above in connection with FIGS. 6-42.

[0155] In one embodiment, the aperture 128 is substantially circular and is substantially centered in the mask 100. The size of the aperture 128 may be any size that is effective to increase the depth of focus of an eye of a patient suffering from presbyopia. For example, the aperture 128 can be circular, having a diameter of less than about 2.2 mm in one embodiment. In another embodiment, the diameter of the aperture is between about 1.8 mm and about 2.2 mm. In another embodiment, the aperture 128 is circular and has a diameter of about 1.8 mm or less. In another embodiment, the diameter of the aperture is about 1.6 mm. Most apertures will have a diameter within the range of from about 1.0 mm to about 2.5 mm, and often within the range of from about 1.3 mm to about 1.9 mm.

[0156] The non-transmissive portion 132 is configured to prevent transmission of radiant energy through the mask 100. For example, in one embodiment, the non-transmissive portion 132 prevents transmission of substantially all of at least a portion of the spectrum of the incident radiant energy. In one embodiment, the non-transmissive portion 132 is configured to prevent transmission of substantially all visible light, e.g., radiant energy in the electromagnetic spectrum that is visible to the human eye. The non-transmissive portion 132 may substantially prevent transmission of radiant energy outside the range visible to humans in some embodiments.

[0157] As discussed above in connection with FIG. 3, preventing transmission of light through the non-transmissive portion 132 decreases the amount of light that reaches the retina and the fovea that would not converge at the retina and fovea to form a sharp image. As discussed above in connection with FIG. 4, the size of the aperture 128 is such that the light transmitted therethrough generally converges at the retina or fovea. Accordingly, a much sharper image is presented to the eye than would otherwise be the case without the mask 100.

[0158] In one embodiment, the non-transmissive portion 132 prevents transmission of about 90 percent of incident light. In another embodiment, the non-transmissive portion 132 prevents transmission of about 92 percent of all incident light. The non-transmissive portion 132 of the mask 100 may be configured to be opaque to prevent the transmission of light. As used herein the term "opaque" is intended to be a broad term meaning capable of preventing the transmission of radiant energy, e.g., light energy, and also covers structures and arrangements that absorb or otherwise block all or less than all or at least a substantial portion of the light. In one embodiment, at least a portion of the body 104 is configured to be opaque to more than 99 percent of the light incident thereon.

[0159] As discussed above, the non-transmissive portion 132 may be configured to prevent transmission of light without absorbing the incident light. For example, the mask 100 could be made reflective or could be made to interact with the light in a more complex manner, as discussed in U.S. Pat. No. 6,551,424, issued Apr. 29, 2003, which is hereby incorporated by reference herein in its entirety.

[0160] As discussed above, the mask 100 also has a nutrient transport structure that in some embodiments comprises the plurality of holes 120. The presence of the plurality of holes 120 (or other transport structure) may affect the transmission of light through the non-transmissive portion 132 by potentially allowing more light to pass through the mask 100. In one embodiment, the non-transmissive portion 132 is configured to absorb about 99 percent or more of the incident light from passing through the mask 100 without holes 120 being present. The presence of the plurality of holes 120 allows more light to pass through the non-transmissive portion 132 such that only about 92 percent of the light incident on the non-transmissive portion 132 is prevented from passing through the non-transmissive portion 132. The holes 120 may reduce the benefit of the aperture 128 on the depth of focus of the eye by allowing more light to pass through the non-transmissive portion to the retina.

[0161] Reduction in the depth of focus benefit of the aperture 128 due to the holes 120 is balanced by the nutrient transmission benefits of the holes 120. In one embodiment, the transport structure 116 (e.g., the holes 120) is capable of substantially maintaining natural nutrient flow from a first corneal layer (i.e., one that is adjacent to the anterior surface 108 of the mask 100) to the second corneal layer (i.e., one that is adjacent to the posterior surface 112 of the mask 100). The plurality of holes 120 are configured to enable nutrients to pass through the mask 100 between the anterior surface 108 and the posterior surface 112. As discussed above, the holes 120 of the mask 100 shown in FIG. 43 may be located anywhere on the mask 100. Other mask embodiments described herein below locate substantially all of the nutrient transport structure in one or more regions of a mask.

[0162] The holes 120 of FIG. 43 extends at least partially between the anterior surface 108 and the posterior surface 112 of the mask 100. In one embodiment, each of the holes 120 includes a hole entrance 140 and a hole exit 164. The hole entrance 140 is located adjacent to the anterior surface 108 of the mask 100. The hole exit 164 is located adjacent to the posterior surface 112 of the mask 100. In one embodiment, each of the holes 120 extends the entire distance between the anterior surface 108 and the posterior surface 112 of the mask 100.

[0163] The transport structure 116 is configured to maintain the transport of one or more nutrients across the mask 100. The transport structure 116 of the mask 100 provides sufficient flow of one or more nutrients across the mask 100 to prevent depletion of nutrients at least at one of the first and second corneal layers (e.g., the layers 1210 and 1220). One nutrient of particular importance to the viability of the adjacent corneal layers is glucose. The transport structure 116 of the mask 100 provides sufficient flow of glucose across the mask 100 between the first and second corneal layers to prevent glucose depletion that would harm the adjacent corneal tissue. Thus, the mask 100 is capable of

substantially maintaining nutrient flow (e.g., glucose flow) between adjacent corneal layers. In one embodiment, the nutrient transport structure 116 is configured to prevent depletion of more than about 4 percent of glucose (or other biological substance) in adjacent tissue of at least one of the first corneal layer and the second corneal layer.

[0164] The holes 120 may be configured to maintain the transport of nutrients across the mask 100. In one embodiment, the holes 120 are formed with a diameter of about 0.015 mm or more. In another embodiment, the holes have a diameter of about 0.020 mm. In another embodiment, the holes have a diameter of about 0.025 mm. In another embodiment, the holes have a diameter of about 0.027 mm. In another embodiment, the holes 120 have a diameter in the range of about 0.020 mm to about 0.029 mm. The number of holes in the plurality of holes 120 is selected such that the sum of the surface areas of the hole entrances 140 of all the holes 100 comprises about 5 percent or more of surface area of the anterior surface 108 of the mask 100. In another embodiment, the number of holes 120 is selected such that the sum of the surface areas of the hole exits 164 of all the holes 120 comprises about 5 percent or more of surface area of the posterior surface 112 of the mask 100. In another embodiment, the number of holes 120 is selected such that the sum of the surface areas of the hole exits 164 of all the holes 120 comprises about 5 percent or more of surface area of the posterior surface 112 of the mask 112 and the sum of the surface areas of the hole entrances 140 of all the holes 120 comprises about 5 percent or more of surface area of the anterior surface 108 of the mask 100. In another embodiment, the plurality of holes 120 may comprise about 1600 microperforations.

[0165] Each of the holes 120 may have a relatively constant cross-sectional area. In one embodiment, the cross-sectional shape of each of the holes 120 is substantially circular. Each of the holes 120 may comprise a cylinder extending between the anterior surface 108 and the posterior surface 112.

[0166] The relative position of the holes 120 is of interest in some embodiments. As discussed above, the holes 120 of the mask 100 are hex-packed, e.g., arranged in a hex pattern. In particular, in this embodiment, each of the holes 120 is separated from the adjacent holes 120 by a substantially constant distance, sometimes referred to herein as a hole pitch. In one embodiment, the hole pitch is about 0.045 mm.

[0167] In a hex pattern, the angles between lines of symmetry are approximately 43 degrees. The spacing of holes along any line of holes is generally within the range of from about 30 microns to about 100 microns, and, in one embodiment, is approximately 43 microns. The hole diameter is generally within the range of from about 10 microns to about 100 microns, and in one embodiment, is approximately 20 microns. The hole spacing and diameter are related if you want to control the amount of light coming through. The light transmission is a function of the sum of hole areas as will be understood by those of skill in the art in view of the disclosure herein.

[0168] The embodiment of FIG. 43 advantageously enables nutrients to flow from the first corneal layer to the second corneal layer. The inventors have discovered that negative visual effects can arise due to the presence of the transport structure 116. For example, in some cases, a hex

packed arrangement of the holes 120 can generate diffraction patterns visible to the patient. For example, patients might observe a plurality of spots, e.g., six spots, surrounding a central light with holes 120 having a hex patterned.

[0169] The inventors have discovered a variety of techniques that produce advantageous arrangements of a transport structure such that diffraction patterns and other deleterious visual effects do not substantially inhibit other visual benefits of a mask. In one embodiment, where diffraction effects would be observable, the nutrient transport structure is arranged to spread the diffracted light out uniformly across the image to eliminate observable spots. In another embodiment, the nutrient transport structure employs a pattern that substantially eliminates diffraction patterns or pushes the patterns to the periphery of the image.

[0170] FIGS. 45B-45C show two embodiments of patterns of holes 220 that may be applied to a mask that is otherwise substantially similar to the mask 100. The holes 220 of the hole patterns of FIGS. 45A-45B are spaced from each other by a random hole spacing or hole pitch. In other embodiments discussed below, holes are spaced from each other by a non-uniform amount, e.g., not a random amount. In one embodiment, the holes 220 have a substantially uniform shape (cylindrical shafts having a substantially constant cross-sectional area). FIG. 45C illustrates a plurality of holes 220 separated by a random spacing, wherein the density of the holes is greater than that of FIG. 45B. Generally, the higher the percentage of the mask body that has holes the more the mask will transport nutrients in a manner similar to the native tissue. One way to provide a higher percentage of hole area is to increase the density of the holes. Increased hole density can also permit smaller holes to achieve the same nutrient transport as is achieved by less dense, larger holes.

[0171] FIG. 46A shows a portion of another mask 200a that is substantially similar to the mask 100, except described differently below. The mask 200a can be made of the materials discussed herein, including those discussed in Section III. The mask 200a can be formed by any suitable process, such as those discussed below in connection with FIGS. 48a-48d and with variations of such processes. The mask 200a has a nutrient transport structure 216a that includes a plurality of holes 220a. A substantial number of the holes 220a have a non-uniform size. The holes 220a may be uniform in cross-sectional shape. The cross-sectional shape of the holes 220a is substantially circular in one embodiment. The holes 220a may be circular in shape and have the same diameter from a hole entrance to a hole exit, but are otherwise non-uniform in at least one aspect, e.g., in size. It may be preferable to vary the size of a substantial number of the holes by a random amount. In another embodiment, the holes 220a are non-uniform (e.g., random) in size and are separated by a non-uniform (e.g., a random) spacing.

[0172] FIG. 46B illustrates another embodiment of a mask 200b that is substantially similar to the mask 100, except as described differently below. The mask 200b can be made of the materials discussed herein, including those discussed in Section III. Also, the mask 200b can be formed by any suitable process, such as those discussed below in connection with FIGS. 48a-48d and with variations of such processes. The mask 200b includes a body 204b. The mask

200b has a transport structure **216b** that includes a plurality of holes **220b** with a non-uniform facet orientation. In particular, each of the holes **220b** has a hole entrance that may be located at an anterior surface of the mask **200b**. A facet of the hole entrance is defined by a portion of the body **204b** of the mask **200b** surrounding the hole entrance. The facet is the shape of the hole entrance at the anterior surface. In one embodiment, most or all the facets have an elongate shape, e.g., an oblong shape, with a long axis and a short axis that is perpendicular to the long axis. The facets may be substantially uniform in shape. In one embodiment, the orientation of facets is not uniform. For example, a substantial number of the facets may have a non-uniform orientation. In one arrangement, a substantial number of the facets have a random orientation. In some embodiments, the facets are non-uniform (e.g., random) in shape and are non-uniform (e.g., random) in orientation.

[0173] Other embodiments may be provided that vary at least one aspect, including one or more of the foregoing aspects, of a plurality of holes to reduce the tendency of the holes to produce visible diffraction patterns or patterns that otherwise reduce the vision improvement that may be provided by a mask with an aperture, such as any of those described above. For example, in one embodiment, the hole size, shape, and orientation of at least a substantial number of the holes may be varied randomly or may be otherwise non-uniform.

[0174] FIG. 47 shows another embodiment of a mask **300** that is substantially similar to any of the masks hereinbefore described, except as described differently below. The mask **300** can be made of the materials discussed herein, including those discussed in Section III. Also, the mask **300** can be formed by any suitable process, such as those discussed below in connection with FIGS. 48a-48d and with variations of such processes. The mask **300** includes a body **304**. The body **304** has an outer peripheral region **305**, an inner peripheral region **306**, and a hole region **307**. The hole region **307** is located between the outer peripheral region **305** and the outer peripheral region **306**. The body **304** may also include an aperture region, where the aperture (discussed below) is not a through hole. The mask **300** also includes a nutrient transport structure **316**. In one embodiment, the nutrient transport structure includes a plurality of holes. At least a substantial portion of the holes (e.g., all of the holes) are located in the hole region **307**. As above, only a portion of the nutrient structure **316** is shown for simplicity. But it should be understood that the hole may be located through the hole region **307**.

[0175] The outer peripheral region **305** may extend from an outer periphery **324** of the mask **300** to a selected outer circumference **326** of the mask **300**. The selected outer circumference **325** of the mask **300** is located a selected radial distance from the outer periphery **324** of the mask **300**. In one embodiment, the selected outer circumference **325** of the mask **300** is located about 0.05 mm from the outer periphery **324** of the mask **300**.

[0176] The inner peripheral region **306** may extend from an inner location, e.g., an inner periphery **326** adjacent an aperture **328** of the mask **300** to a selected inner circumference **327** of the mask **300**. The selected inner circumference **327** of the mask **300** is located a selected radial distance from the inner periphery **326** of the mask **300**. In one

embodiment, the selected inner circumference **327** of the mask **300** is located about 0.05 mm from the inner periphery **326**.

[0177] The mask **300** may be the product of a process that involves random selection of a plurality of locations and formation of holes on the mask **300** corresponding to the locations. As discussed further below, the method can also involve determining whether the selected locations satisfy one or more criteria. For example, one criterion prohibits all, at least a majority, or at least a substantial portion of the holes from being formed at locations that correspond to the inner or outer peripheral regions **305**, **306**. Another criterion prohibits all, at least a majority, or at least a substantial portion of the holes from being formed too close to each other. For example, such a criterion could be used to assure that a wall thickness, e.g., the shortest distance between adjacent holes, is not less than a predetermined amount. In one embodiment, the wall thickness is prevented from being less than about 20 microns.

[0178] In a variation of the embodiment of FIG. 47, the outer peripheral region **305** is eliminated and the hole region **307** extends from the inner peripheral region **306** to an outer periphery **324**. In another variation of the embodiment of FIG. 47, the inner peripheral region **306** is eliminated and the hole region **307** extends from the outer peripheral region **305** to an inner periphery **326**.

[0179] FIG. 44B shows a mask **400** that is similar to the mask **100** except as described differently below. The mask **400** can be made of the materials discussed herein, including those discussed in Section III. The mask **400** can be formed by any suitable process, such as those discussed below in connection with FIGS. 48a-48d and with variations of such processes. The mask **400** includes a body **404** that has an anterior surface **408** and a posterior surface **412**. The mask **400** also includes a nutrient transport structure **4316** that, in one embodiment, includes a plurality of holes **420**. The holes **420** are formed in the body **404** so that nutrient transport is provided but transmission of radiant energy (e.g., light) to the retinal locations adjacent the fovea through the holes **404** is substantially prevented. In particular, the holes **404** are formed such that when the eye with which the mask **1000** is coupled is directed at an object to be viewed, light conveying the image of that object that enters the holes **420** cannot exit the holes along a path ending near the fovea.

[0180] In one embodiment, each of the holes **420** has a hole entrance **460** and a hole exit **464**. Each of the holes **420** extends along a transport axis **466**. The transport axis **466** is formed to substantially prevent propagation of light from the anterior surface **408** to the posterior surface **412** through the holes **420**. In one embodiment, at least a substantial number of the holes **420** have a size to the transport axis **466** that is less than a thickness of the mask **400**. In another embodiment, at least a substantial number of the holes **420** have a longest dimension of a perimeter at least at one of the anterior or posterior surfaces **408**, **412** (e.g., a facet) that is less than a thickness of the mask **400**. In some embodiments, the transport axis **466** is formed at an angle with respect to a mask axis **436** that substantially prevents propagation of light from the anterior surface **408** to the posterior surface **412** through the hole **420**. In another embodiment, the transport axis **466** of one or more holes **420** is formed at an angle with respect to the mask axis **436** that is large enough

to prevent the projection of most of the hole entrance 460 from overlapping the hole exit 464.

[0181] In one embodiment, the hole 420 is circular in cross-section and has a diameter between about 0.5 micron and about 8 micron and the transport axis 466 is between 5 and 85 degrees. The length of each of the holes 420 (e.g., the distance between the anterior surface 408 and the posterior surface 412) is between about 8 and about 92 micron. In another embodiment, the diameter of the holes 420 is about 5 micron and the transport angle is about 40 degrees or more. As the length of the holes 420 increases it may be desirable to include additional holes 420. In some cases, additional holes 420 counteract the tendency of longer holes to reduce the amount of nutrient flow through the mask 400.

[0182] FIG. 44C shows another embodiment of a mask 500 similar to the mask 100, except as described differently below. The mask 500 can be made of the materials discussed herein, including those discussed in Section III. The mask 500 can be formed by any suitable process, such as those discussed below in connection with FIGS. 48a-48d and with variations of such processes. The mask 500 includes a body 504 that has an anterior surface 508, a first mask layer 510 adjacent the anterior surface 508, a posterior surface 512, a second mask layer 514 adjacent the posterior surface 512, and a third mask layer 515 located between the first mask layer 510 and the second mask layer 514. The mask 500 also includes a nutrient transport structure 516 that, in one embodiment, includes a plurality of holes 520. The holes 520 are formed in the body 504 so that nutrient are transported across the mask, as discussed above, but transmission of radiant energy (e.g., light) to retinal locations adjacent the fovea through the holes 504 is substantially prevented. In particular, the holes 504 are formed such that when the eye with which the mask 500 is coupled is directed at an object to be viewed, light conveying the image of that object that enters the holes 520 cannot exit the holes along a path ending near the fovea.

[0183] In one embodiment, at least one of the holes 520 extends along a non-linear path that substantially prevents propagation of light from the anterior surface to the posterior surface through the at least one hole. In one embodiment, the mask 500 includes a first hole portion 520a that extends along a first transport axis 566a, the second mask layer 514 includes a second hole portion 520b extending along a second transport axis 566b, and the third mask layer 515 includes a third hole portion 520c extending along a third transport axis 566c. The first, second, and third transport axes 566a, 566b, 566c preferably are not collinear. In one embodiment, the first and second transport axes 566a, 566b are parallel but are off-set by a first selected amount. In one embodiment, the second and third transport axes 566b, 566c are parallel but are off-set by a second selected amount. In the illustrated embodiment, each of the transport axes 566a, 566b, 566c are off-set by one-half of the width of the hole portions 520a, 520b, 520c. Thus, the inner-most edge of the hole portion 520a is spaced from the axis 536 by a distance that is equal to or greater than the distance of the outer-most edge of the hole portion 520b from the axis 536. This spacing substantially prevents light from passing through the holes 520 from the anterior surface 508 to the posterior surface 512.

[0184] In one embodiment, the first and second amounts are selected to substantially prevent the transmission of light

therethrough. The first and second amounts of off-set may be achieved in any suitable fashion. One technique for forming the hole portions 520a, 520b, 520c with the desired off-set is to provide a layered structure. As discussed above, the mask 500 may include the first layer 510, the second layer 514, and the third layer 515. FIG. 44C shows that the mask 500 can be formed with three layers. In another embodiment, the mask 500 is formed of more than three layers. Providing more layers may advantageously further decrease the tendency of light to be transmitted through the holes 490 onto the retina. This has the benefit of reducing the likelihood that a patient will observe or otherwise perceive a patten that will detract from the vision benefits of the mask 500. A further benefit is that less light will pass through the mask 500, thereby enhancing the depth of focus increase due to the pin-hole sized aperture formed therein.

[0185] In any of the foregoing mask embodiments, the body of the mask may be formed of a material selected to provide adequate nutrient transport and to substantially prevent negative optic effects, such as diffraction, as discussed above. In various embodiments, the masks are formed of an open cell foam material. In another embodiment, the masks are formed of an expanded solid material.

[0186] As discussed above in connection with FIGS. 45B and 45C, various random patterns of holes may advantageously be provided for nutrient transport. In some embodiment, it may be sufficient to provide regular patterns that are non-uniform in some aspect. Non-uniform aspects to the holes may be provided by any suitable technique.

[0187] In a first step of one technique, a plurality of locations 220' is generated. The locations 220' are a series of coordinates that may comprise a non-uniform pattern or a regular pattern. The locations 220' may be randomly generated or may be related by a mathematical relationship (e.g., separated by a fixed spacing or by an amount that can be mathematically defined). In one embodiment, the locations are selected to be separated by a constant pitch or spacing and may be hex packed.

[0188] In a second step, a subset of the locations among the plurality of locations 220' is modified to maintain a performance characteristic of the mask. The performance characteristic may be any performance characteristic of the mask. For example, the performance characteristic may relate to the structural integrity of the mask. Where the plurality of locations 220' is selected at random, the process of modifying the subset of locations may make the resulting pattern of holes in the mask a "pseudo-random" pattern.

[0189] Where a hex packed pattern of locations (such as the locations 120' of FIG. 45A) is selected in the first step, the subset of locations may be moved with respect to their initial positions as selected in the first step. In one embodiment, each of the locations in the subset of locations is moved by an amount equal to a fraction of the hole spacing. For example, each of the locations in the subset of locations may be moved by an amount equal to one-quarter of the hole spacing. Where the subset of locations is moved by a constant amount, the locations that are moved preferably are randomly or pseudo-randomly selected. In another embodiment, the subset of location is moved by a random or a pseudo-random amount.

[0190] In one technique, an outer peripheral region is defined that extends between the outer periphery of the mask

and a selected radial distance of about 0.05 mm from the outer periphery. In another embodiment, an inner peripheral region is defined that extends between an aperture of the mask and a selected radial distance of about 0.05 mm from the aperture. In another embodiment, an outer peripheral region is defined that extends between the outer periphery of the mask and a selected radial distance and an inner peripheral region is defined that extends between the aperture of the mask and a selected radial distance from the aperture. In one technique, the subset of location is modified by excluding those locations that would correspond to holes formed in the inner peripheral region or the outer peripheral region. By excluding locations in at least one of the outer peripheral region and the inner peripheral region, the strength of the mask in these regions is increased. Several benefits are provided by stronger inner and outer peripheral regions. For example, the mask may be easier to handle during manufacturing or when being applied to a patient without causing damage to the mask.

[0191] In another embodiment, the subset of locations is modified by comparing the separation of the holes with minimum and or maximum limits. For example, it may be desirable to assure that no two locations are closer than a minimum value. In some embodiments this is important to assure that the wall thickness, which corresponds to the separation between adjacent holes, is no less than a minimum amount. As discussed above, the minimum value of separation is about 20 microns in one embodiment, thereby providing a wall thickness of no less than about 20 microns.

[0192] In another embodiment, the subset of locations is modified and/or the pattern of location is augmented to maintain an optical characteristic of the mask. For example, the optical characteristic may be opacity and the subset of locations may be modified to maintain the opacity of a non-transmissive portion of a mask. In another embodiment, the subset of locations may be modified by equalizing the density of holes in a first region of the body compared with the density of holes in a second region of the body. For example, the locations corresponding to the first and second regions of the non-transmissive portion of the mask may be identified. In one embodiment, the first region and the second region are arcuate regions (e.g., wedges) of substantially equal area. A first areal density of locations (e.g., locations per square inch) is calculated for the locations corresponding to the first region and a second areal density of locations is calculated for the locations corresponding to the second region. In one embodiment, at least one location is added to either the first or the second region based on the comparison of the first and second areal densities. In another embodiment, at least one location is removed based on the comparison of the first and second areal densities.

[0193] The subset of locations may be modified to maintain nutrient transport of the mask. In one embodiment, the subset of location is modified to maintain glucose transport.

[0194] In a third step, a hole is formed in a body of a mask at locations corresponding to the pattern of locations as modified, augmented, or modified and augmented. The holes are configured to substantially maintain natural nutrient flow from the first layer to the second layer without producing visible diffraction patterns.

VI. Methods of Applying Pinhole Aperture Devices

[0195] The various masks discussed herein can be used to improve the vision of a presbyopic patient as well as

patient's with other vision problems. The masks discussed herein can be deployed in combination with a LASIK procedure, to eliminate the effects of abrasions, aberrations, and divots in the cornea. It is also believed that the masks disclosed herein can be used to treat patients suffering from macular degeneration, e.g., by directing light rays to unaffected portions of retina, thereby improving the vision of the patient. Whatever treatment is contemplated, more precise alignment of the central region of a mask that has a pin-hole aperture with the line of sight or visual axis of the patient is believed to provide greater clinical benefit to the patient. Other ocular devices that do not require a pin-hole aperture can also benefit from the alignment techniques discussed below. Also, various structures and techniques that can be used to remove an ocular devices are discussed below.

A. Alignment of the Pinhole Aperture with the Patient's Visual Axis

[0196] Alignment of the central region of the pinhole aperture **38**, in particular, the optical axis **39** of the mask **34** with the visual axis of the eye **10** may be achieved in a variety of ways. In one technique, an optical device employs input from the patient to locate the visual axis in connection with a procedure to implant the mask **34**. This technique is described in more detail in U.S. patent application Ser. No. 11/000,562, filed Dec. 1, 2004, the entire contents of which is hereby expressly incorporated by reference herein.

[0197] In other embodiments, systems and methods identify one or more visible ocular features that correlate to the line of sight. The one or more visible ocular feature(s) is observed while the mask is being applied to the eye. Alignment using a visible ocular feature enables the mask to perform adequately to increase depth of focus. In some applications, a treatment method enhances the correlation of the visible ocular feature and the line of sight to maintain or improve alignment of the mask axis and the line of sight.

[0198] Accurate alignment of the mask is believed to improve the clinical benefit of the mask. However, neither the optical axis of the mask nor the line of sight of the patient is generally visible during the surgical procedures contemplated for implanting masks. However, substantial alignment of the optical axis of the mask and the line of sight may be achieved by aligning a visible feature of the mask with a visible feature of the eye, e.g., a visible ocular feature. As used herein, the term "visible ocular feature" is a broad term that includes features viewable with a viewing aid, such as a surgical microscope or loupes, as well as those visible to the unaided eye. Various methods are discussed below that enhance the accuracy of the placement of the mask using a visible ocular feature. These methods generally involve treating the eye to increase the correlation between the location of the visible ocular feature and the line of sight or to increase the visibility of the ocular feature.

[0199] **FIG. 48** is a flow chart illustrating one method of aligning a mask with an axis of the eye using a visible ocular feature. The method may include a step of identifying a visible ocular feature, a combination of visible ocular features, or a combination of a visible ocular feature and an optical effect that sufficiently correlate with the location of the line of sight of the eye. In one technique the entrance pupil or other visible ocular feature could be used alone to estimate the location of the line of sight. In another technique, the location of the line of sight can be estimated to be

located between, e.g., half-way between, the center of the entrance pupil and the first Purkinje image. Other estimates can be based on a combination of two or more of the first Purkinje image, the second Purkinje image, the third Purkinje image, and the fourth Purkinje image. Other estimates can be based on one or more Purkinje image and one or more other anatomical features. In another technique, the location of the line of sight can be estimated as being located at the center of the pupil if the first Purkinje image is located close to the center of the entrance pupil. A single Purkinje image may provide an adequate estimate of the location of the line of sight if the Purkinje image is generated by a beam having a fixed or a known angle of incidence relative to a surface of the eye. The method may also include a step of identifying a visible feature of the mask to be aligned with a visible ocular feature, as discussed further below.

[0200] In a step 1000, an eye is treated to affect or alter, preferably temporarily, a visible ocular feature. In some embodiments, the feature of the eye is altered to increase the correlation of the location of the ocular feature to the line of sight of the eye. In some cases, the treatment of step 1000 enhances the visibility of the ocular feature to the surgeon. The ocular feature may be any suitable feature, such as the pupil or any other feature that correlates or can be altered by a treatment to correlate with the line of sight of the patient. Some techniques involve the alignment of a feature of a mask with the pupil or a portion of the pupil. One technique for enhancing the visibility of the pupil or the correlation of the location of the pupil with the line of sight involves manipulating the size of the pupil, e.g., increasing or decreasing the pupil size.

[0201] In connection with the method of FIG. 48, any suitable criteria can be used to confirm alignment of an eye and a mask with a pin-hole aperture. For example, the mask can be considered aligned with the eye when any feature of the mask is aligned with any anatomical landmark on the eye so that an axis passing through the center of the pin-hole aperture is co-linear with or substantially co-linear with an optical axis of the eye, such as the line of sight and an axis passing through the center of the entrance pupil and the center of the eyeball. As used herein, "anatomical landmark" is a broad term that includes an visible ocular feature, such as the center of the entrance pupil, the intersection of the line of sight with a selected corneal layer, the inner periphery of the iris, the outer periphery of the iris, the inner periphery of the sclera, the boundary between the iris and the pupil, the boundary between the iris and the sclera, the location of the first Purkinje image, the location of the second Purkinje image, the location of the third Purkinje image, the location of the fourth Purkinje image, the relative position of any combination of Purkinje images, the combination of the location of a Purkinje image and any other anatomical landmark, and any combination of the foregoing or other anatomical feature.

[0202] The pupil size may be decreased by any suitable technique, including pharmacologic manipulation and light manipulation. One agent used in pharmacologic manipulation of pupil size is pilocarpine. Pilocarpine reduces the size of the pupil when applied to the eye. One technique for applying pilocarpine is to inject an effective amount into the eye. Other agents for reducing pupil size include: carbachol, demecarium, isofluorophate, physostigmine, aceclidine, and echothiophate.

[0203] Pilocarpine is known to shift the location of the pupil nasally in some cases. This can be problematic for some ocular procedures, e.g., those procedures directed at improving distance vision. The applicant has discovered, however, that such a shift does not significantly reduce the efficacy of the masks described herein.

[0204] While the alignment of the masks described herein with the line of sight is not significantly degraded by the use of pilocarpine, an optional step of correcting for the nasal shift of the pupil may be performed.

[0205] In one variation, the treatment of the step 1000 involves increasing pupil size. This technique may be more suitable where it is desired to align a visible mask feature near an outer periphery of the mask with the pupil. These techniques are discussed further below.

[0206] As discussed above, the treatment of the step 1000 can involve non-pharmacologic techniques for manipulating a visible ocular feature. One non-pharmacologic technique involves the use of light to cause the pupil size to change. For example, a bright light can be directed into the eye to cause the pupil to constrict. This approach may substantially avoid displacement of the pupil that has been observed in connection with some pharmacologic techniques. Light can also be used to increase pupil size. For example, the ambient light can be reduced to cause the pupil to dilate. A dilated pupil may provide some advantages in connection with aligning to a visible mask feature adjacent to an outer periphery of a mask, as discussed below.

[0207] In a step 1004, a visible feature of a mask is aligned with the ocular feature identified in connection with step 1000. As discussed above, the mask may have an inner periphery, an outer periphery, and a pin-hole aperture located within the inner periphery. The pin-hole aperture may be centered on a mask axis. Other advantageous mask features discussed above may be included in masks applied by the methods illustrated by FIG. 48. For example, such features may include nutrient transport structures configured to substantially eliminate diffraction patterns, structures configured to substantially prevent nutrient depletion in adjacent corneal tissue, and any other mask feature discussed above in connection with other masks.

[0208] One technique involves aligning at least a portion of the inner periphery of a mask with an anatomical landmark. For example, the inner periphery of the mask could be aligned with the inner periphery of the iris. This may be accomplished using unaided vision or a viewing aid, such as loupes or a surgical microscope. The mask could be aligned so that substantially the same spacing is provided between the inner periphery of the mask and the inner periphery of the iris. This technique could be facilitated by making the iris constrict, as discussed above. A viewing aid may be deployed to further assist in aligning the mask to the anatomical landmark. For example, a viewing aid could include a plurality of concentric markings that the surgeon can use to position the mask. Where the inner periphery of the iris is smaller than the inner periphery of the mask, a first concentric marking can be aligned with the inner periphery of the iris and the mask could be positioned so that a second concentric marking is aligned with the inner periphery of the mask. The second concentric marking would be farther from the common center than the first concentric marking in this example.

[0209] In another technique, the outer periphery of the mask could be aligned with an anatomical landmark, such as the inner periphery of the iris. This technique could be facilitated by dilating the pupil. This technique may be enhanced by the use of a viewing aid, which could include a plurality of concentric markings, as discussed above. In another technique, the outer periphery of the mask could be aligned with an anatomical landmark, such as the boundary between the iris and the sclera. This technique may be facilitated by the use of a viewing aid, such as a plurality of concentric markings.

[0210] In another technique, the mask can be aligned so that substantially the same spacing is provided between the inner periphery of the mask and the inner periphery of the iris. In this technique, the pupil preferably is constricted so that the diameter of the pupil is less than the diameter of the pin-hole aperture.

[0211] Alternatively, an artifact can be formed in the mask that gives a visual cue of proper alignment. For example, there could be one or more window portions formed in the mask through which the edge of the pupil could be observed. The window portions could be clear graduations or they could be at least partially opaque regions through which the pupil could be observed. In one technique, the surgeon moves the mask until the pupil can be seen in corresponding window portions on either side of the pin-hole aperture. The window portions enable a surgeon to align a visible ocular feature located beneath a non-transparent section of the mask with a feature of the mask. This arrangement enables alignment without a great amount of pupil constriction, e.g., where the pupil is not fully constricted to a size smaller than the diameter of the inner periphery.

[0212] Preferably the alignment of the ocular feature with one or more visible mask features causes the mask axis to be substantially aligned with the line of sight of the eye. "Substantial alignment" of the mask axis with the eye, e.g., with the line of sight of the eye (and similar terms, such as "substantially collinear") can be said to have been achieved when a patient's vision is improved by the implantation of the mask. In some cases, substantial alignment can be said to have been achieved when the mask axis is within a circle centered on the line of sight and having a radius no more than 5 percent of the radius of the inner periphery of the mask. In some cases, substantial alignment can be said to have been achieved when the mask axis is within a circle centered on the line of sight and having a radius no more than 10 percent of the radius of the inner periphery of the mask. In some cases, substantial alignment can be said to have been achieved when the mask axis is within a circle centered on the line of sight and having a radius no more than 15 percent of the radius of the inner periphery of the mask. In some cases, substantial alignment can be said to have been achieved when the mask axis is within a circle centered on the line of sight and having a radius no more than 20 percent of the radius of the inner periphery of the mask. In some cases, substantial alignment can be said to have been achieved when the mask axis is within a circle centered on the line of sight and having a radius no more than 25 percent of the radius of the inner periphery of the mask. In some cases, substantial alignment can be said to have been achieved when the mask axis is within a circle centered on the line of sight and having a radius no more than 30 percent of the radius of the inner periphery of the

mask. As discussed above, the alignment of the mask axis and the line of sight of the patient is believed to enhance the clinical benefit of the mask.

[0213] In a step 1008, the mask is applied to the eye of the patient. Preferably the alignment of the optical axis of the mask and the line of sight of the patient is maintained while the mask is applied to the eye of the patient. In some cases, this alignment is maintained by maintaining the alignment of a mask feature, e.g., a visible mask feature, and a pupil feature, e.g., a visible pupil feature. For example, one technique maintains the alignment of at least one of the inner periphery and the outer periphery of the mask and the pupil while the mask is being applied to the eye of the patient.

[0214] As discussed above, a variety of techniques are available for applying a mask to the eye of a patient. Any suitable technique of applying a mask may be employed in connection with the method illustrated in FIG. 48. For example, as set forth above in connection with FIGS. 50A-51C, various techniques may be employed to position the mask at different depths or between different layers within the cornea. In particular, in one technique, a corneal flap of suitable depth is hinged open. The depth of the flap is about the outermost 20% of the thickness of the cornea in one technique. In another technique, the depth of the flap is about the outermost 10% of the thickness of the cornea. In another technique, the depth of the flap is about the outermost 5% of the thickness of the cornea. In another technique, the depth of the flap is in the range of about the outermost 5% to about the outermost 10% of the thickness of the cornea. In another technique, the depth of the flap is in the range of about the outermost 5% to about the outermost 20% of the thickness of the cornea. Other depths and ranges are possible for other techniques.

[0215] Thereafter, in one technique, the mask is placed on a layer of the cornea such that at least one of the inner periphery and the outer periphery of the mask is at a selected position relative to the pupil. In variations on this technique, other features of the mask may be aligned with other ocular features. Thereafter, the hinged corneal flap is placed over the mask.

[0216] Additional techniques for applying a mask are discussed above in connection with FIGS. 52A-53. These methods may be modified for use in connection with alignment using visible features. These techniques enable the mask to be initially placed on the corneal layer that is lifted from the eye. The initial placement of the mask on the lifted corneal layer may be before or after alignment of a visible ocular feature with a visible mask feature. In some techniques, primary and secondary alignment steps are performed before and after the initial placement of the mask on the lifted corneal layer.

[0217] Many additional variations of the foregoing methods are also possible. The alignment methods involving alignment of visible features may be combined with any of the techniques discussed above in connection with optically locating the patient's line of sight. One technique involves removing an epithelial sheet and creating a depression in the Bowman's membrane or in the stroma. Also, the mask can be placed in a channel formed in the cornea, e.g., in or near the top layers of the stroma. Another useful technique for preparing the cornea involves the formation of a pocket within the cornea. These methods related to preparation of the cornea are described in greater detail above.

[0218] Some techniques may benefit from the placement of a temporary post-operative covering, such as a contact lens or other covering, over the flap until the flap has healed. In one technique, a covering is placed over the flap until an epithelial sheet adheres to the mask or grows over an exposed layer, such as the Bowman's membrane.

B. Methods of Applying a Mask

[0219] Having described method for locating the visual axis of the eye 10 or a visible ocular feature that indicates the location thereof, and for visually marking the visual axis, various methods for applying a mask to the eye will be discussed.

[0220] FIG. 49 shows one technique for screening a patient interested in increasing his or her depth of focus. The process begins at step 1100, in which the patient is fitted with soft contact lenses, i.e., a soft contact lens is placed in each of the patient's eyes. If needed, the soft contact lenses may include vision correction. Next, at step 1110, the visual axis of each of the patient's eyes is located as described above. At a step 1120, a mask, such as any of those described above, is placed on the soft contact lenses such that the optical axis of the aperture of the mask is aligned with the visual axis of the eye. In this position, the mask will be located generally concentric with the patient's pupil. In addition, the curvature of the mask should parallel the curvature of the patient's cornea. The process continues at a step 1130, in which the patient is fitted with a second set of soft contact lenses, i.e., a second soft contact lens is placed over the mask in each of the patient's eyes. The second contact lens holds the mask in a substantially constant position. Last, at step 1140, the patient's vision is tested. During testing, it is advisable to check the positioning of the mask to ensure that the optical axis of the aperture of the mask is substantially collinear with the visual axis of the eye. Further details of testing are set forth in U.S. Pat. No. 6,551,424, issued Apr. 29, 2003, incorporated by reference herein in its entirety.

[0221] In accordance with a still further embodiment of the invention, a mask is surgically implanted into the eye of a patient interested in increasing his or her depth of focus. For example, a patient may suffer from presbyopia, as discussed above. The mask may be a mask as described herein, similar to those described in the prior art, or a mask combining one or more of these properties. Further, the mask may be configured to correct visual aberrations. To aid the surgeon surgically implanting a mask into a patient's eye, the mask may be pre-rolled or folded for ease of implantation.

[0222] The mask may be implanted in several locations. For example, the mask may be implanted underneath the cornea's epithelium sheet, beneath the cornea's Bowman membrane, in the top layer of the cornea's stroma, or in the cornea's stroma. When the mask is placed underneath the cornea's epithelium sheet, removal of the mask requires little more than removal of the cornea's epithelium sheet.

[0223] FIGS. 50a through 50c show a mask 1200 inserted underneath an epithelium sheet 1210. In this embodiment, the surgeon first removes the epithelium sheet 1210. For example, as shown in FIG. 50a, the epithelium sheet 1210 may be rolled back. Then, as shown in FIG. 50b, the surgeon creates a depression 1215 in a Bowman's membrane 420 corresponding to the visual axis of the eye. The visual axis

of the eye may be located as described above and may be marked by use of the alignment apparatus 1200 or other similar apparatus. The depression 1215 should be of sufficient depth and width to both expose the top layer 1230 of the stroma 1240 and to accommodate the mask 1200. The mask 1200 is then placed in the depression 1215. Because the depression 1215 is located in a position to correspond to the visual axis of the patient's eye, the central axis of the pinhole aperture of the mask 1200 will be substantially collinear with the visual axis of the eye. This will provide the greatest improvement in vision possible with the mask 1200. Last, the epithelium sheet 1210 is placed over the mask 1200. Over time, as shown in FIG. 50c, the epithelium sheet 1210 will grow and adhere to the top layer 1230 of the stroma 1240, as well as the mask 1200 depending, of course, on the composition of the mask 1200. As needed, a contact lens may be placed over the incised cornea to protect the mask.

[0224] FIGS. 51a through 51c show a mask 1300 inserted beneath a Bowman's membrane 1320 of an eye. In this embodiment, as shown in FIG. 51a, the surgeon first hinges open the Bowman's membrane 1320. Then, as shown in FIG. 51b, the surgeon creates a depression 1315 in a top layer 1300 of a stroma 1340 corresponding to the visual axis of the eye. The visual axis of the eye may be located as described above and may be marked by any suitable technique, for example using a visible ocular feature or a technique employing patient input. The depression 1315 should be of sufficient depth and width to accommodate the mask 1300. Then, the mask 1300 is placed in the depression 1315. Because the depression 1315 is located in a position to correspond to the visual axis of the patient's eye, the central axis of the pinhole aperture of the mask 1300 will be substantially collinear with the visual axis of the eye. This will provide the greatest improvement in vision possible with the mask 1300. Last, the Bowman's membrane 1320 is placed over the mask 1300. Over time, as shown in FIG. 51c, the epithelium sheet 1310 will grow over the incised area of the Bowman's membrane 1320. As needed, a contact lens may be placed over the incised cornea to protect the mask.

[0225] In another embodiment, a mask of sufficient thinness, i.e., less than substantially 20 microns, may be placed underneath epithelium sheet 1210. In another embodiment, a mask or an optic having a thickness less than about 20 microns may be placed beneath Bowman's membrane 1320 without creating a depression in the top layer of the stroma.

[0226] In an alternate method for surgically implanting a mask in the eye of a patient, the mask may be threaded into a channel created in the top layer of the stroma. In this method, a curved channeling tool creates a channel in the top layer of the stroma, the channel being in a plane parallel to the surface of the cornea. The channel is formed in a position corresponding to the visual axis of the eye. The channeling tool either pierces the surface of the cornea or, in the alternative, is inserted via a small superficial radial incision. In the alternative, a laser focusing an ablative beam may create the channel in the top layer of the stroma. In this embodiment, the mask may be a single segment with a break, or it may be two or more segments. In any event, the mask in this embodiment is positioned in the channel and is thereby located so that the central axis of the pinhole aperture formed by the mask is substantially collinear with

the patient's visual axis to provide the greatest improvement in the patient's depth of focus.

[0227] In another alternate method for surgically implanting a mask in the eye of a patient, the mask may be injected into the top layer of the stroma. In this embodiment, an injection tool with a stop penetrates the surface of the cornea to the specified depth. For example, the injection tool may be a ring of needles capable of producing a mask with a single injection. In the alternative, a channel may first be created in the top layer of the stroma in a position corresponding to the visual axis of the patient. Then, the injector tool may inject the mask into the channel. In this embodiment, the mask may be a pigment, or it may be pieces of pigmented material suspended in a bio-compatible medium. The pigment material may be made of a polymer or, in the alternative, made of a suture material. In any event, the mask injected into the channel is thereby positioned so that the central axis of the pinhole aperture formed by the pigment material is substantially collinear with the visual axis of the patient.

[0228] In another method for surgically implanting a mask in the eye of a patient, the mask may be placed beneath the corneal flap created during keratectomy, when the outermost 20% of the cornea is hinged open. As with the implantation methods discussed above, a mask placed beneath the corneal flap created during keratectomy should be substantially aligned with the patient's visual axis, as discussed above, for greatest effect.

[0229] In another method for surgically implanting a mask in the eye of a patient, the mask may be aligned with the patient's visual axis and placed in a pocket created in the cornea's stroma.

[0230] Further details concerning alignment apparatuses are disclosed in U.S. application Ser. No. 10/854,032, filed May 26, 2004, incorporated by reference herein in its entirety. Further variations on techniques involving pharmacologic manipulation for alignment or other purposes are discussed in U.S. application Ser. No. 11/257,505, filed Oct. 24, 2005, which is hereby incorporated by reference herein in its entirety.

VII. Further Methods of Treating a Patient

[0231] As discussed above in, various techniques are particularly suited for treating a patient by applying masks such as those disclosed herein to an eye. For example, in some techniques, a visual cue in the form of a projected image for a surgeon is provided during a procedure for applying a mask. In addition, some techniques for treating a patient involve positioning an implant with the aid of a marked reference point. These methods are illustrated by **FIGS. 52-53B**.

[0232] In one method, a patient is treated by placing an implant **1400** in a cornea **1404**. A corneal flap **1408** is lifted to expose a surface in the cornea **1404** (e.g., an intracorneal surface). Any suitable tool or technique may be used to lift the corneal flap **1408** to expose a surface in the cornea **1404**. For example, a blade (e.g., a microkeratome), a laser or an electrosurgical tool could be used to form a corneal flap. A reference point **1412** on the cornea **1404** is identified. The reference point **1412** thereafter is marked in one technique, as discussed further below. The implant **1400** is positioned

on the intracorneal surface. In one embodiment, the flap **1408** is then closed to cover at least a portion of the implant **1400**.

[0233] The surface of the cornea that is exposed is a stromal surface in one technique. The stromal surface may be on the corneal flap **1408** or on an exposed surface from which the corneal flap **1408** is removed.

[0234] The reference point **1412** may be identified in any suitable manner. For example, the alignment devices and methods described above may be used to identify the reference point **1412**. In one technique, identifying the reference point **1412** involves illuminating a light spot (e.g., a spot of light formed by all or a discrete portion of radiant energy corresponding to visible light, e.g., red light). As discussed above, the identifying of a reference point may further include placing liquid (e.g., a fluorescein dye or other dye) on the intracorneal surface. Preferably, identifying the reference point **1412** involves alignment using any of the techniques described herein.

[0235] As discussed above, various techniques may be used to mark an identified reference point. In one technique the reference point is marked by applying a dye to the cornea or otherwise spreading a material with known reflective properties onto the cornea. As discussed above, the dye may be a substance that interacts with radiant energy to increase the visibility of a marking target or other visual cue. The reference point may be marked by a dye with any suitable tool. The tool is configured so that it bites into a corneal layer, e.g., an anterior layer of the epithelium, and delivers a thin ink line into the corneal layer in one embodiment. The tool may be made sharp to bite into the epithelium. In one application, the tool is configured to deliver the dye as discussed above upon being lightly pressed against the eye. This arrangement is advantageous in that it does not form a larger impression in the eye. In another technique, the reference point may be marked by making an impression (e.g., a physical depression) on a surface of the cornea with or without additional delivery of a dye. In another technique, the reference point may be marked by illuminating a light or other source of radiant energy, e.g., a marking target illuminator and projecting that light onto the cornea (e.g., by projecting a marking target).

[0236] Any of the foregoing techniques for marking a reference point may be combined with techniques that make a mark that indicates the location of an axis of the eye, e.g., the visual axis or line-of-sight of the eye. In one technique, a mark indicates the approximate intersection of the visual axis and a surface of the cornea. In another technique, a mark is made approximately radially symmetrically disposed about the intersection of the visual axis and a surface of the cornea.

[0237] As discussed above, some techniques involve making a mark on an intracorneal surface. The mark may be made by any suitable technique. In one technique a mark is made by pressing an implement against the intracorneal surface. The implement may form a depression that has a size and shape that facilitate placement of a mask. For example, in one form the implement is configured to form a circular ring (e.g., a thin line of dye, or a physical depression, or both) with a diameter that is slightly larger than the outer diameter of a mask to be implanted. The circular ring can be formed to have a diameter between about 4 mm and

about 5 mm. The intracorneal surface is on the corneal flap **1408** in one technique. In another technique, the intracorneal surface is on an exposed surface of the cornea from which the flap was removed. This exposed surface is sometimes referred to as a tissue bed.

[0238] In another technique, the corneal flap **1408** is lifted and thereafter is laid on an adjacent surface **1416** of the cornea **1404**. In another technique, the corneal flap **1408** is laid on a removable support **1420**, such as a sponge. In one technique, the removable support has a surface **1424** that is configured to maintain the native curvature of the corneal flap **1408**.

[0239] FIG. 52 shows that the marked reference point **1412** is helpful in positioning an implant on an intracorneal surface. In particular, the marked reference point **1412** enables the implant to be positioned with respect to the visual axis of the eye. In the illustrated embodiment, the implant **1400** is positioned so that a centerline of the implant, indicated as M_{CL} , extends through the marked reference point **1412**.

[0240] FIG. 52A illustrates another technique wherein a reference **1412'** is a ring or other two dimensional mark. In such a case, the implant **1400** may be placed so that an outer edge of the implant and the ring correspond, e.g., such that the ring and the implant **1400** share the same or substantially the same center. Preferably, the ring and the implant **1400** are aligned so that the centerline of the implant M_{CL} is on the line of sight of the eye, as discussed above. The ring is shown in dashed lines because in the illustrated technique, it is formed on the anterior surface of the corneal flap **1408**.

[0241] In one technique, the corneal flap **1408** is closed by returning the corneal flap **1408** to the cornea **1404** with the implant **1400** on the corneal flap **1408**. In another technique, the corneal flap **1408** is closed by returning the corneal flap **1408** to the cornea **1404** over the implant **1400**, which previously was placed on the tissue bed (the exposed intracorneal surface).

[0242] When the intracorneal surface is a stromal surface, the implant **1400** is placed on the stromal surface. At least a portion of the implant **1400** is covered. In some techniques, the implant **1400** is covered by returning a flap with the implant **1400** thereon to the cornea **1404** to cover the stromal surface. In one technique, the stromal surface is exposed by lifting an epithelial layer to expose stroma. In another technique, the stromal surface is exposed by removing an epithelial layer to expose stroma. In some techniques, an additional step of replacing the epithelial layer to at least partially cover the implant **1400** is performed.

[0243] After the flap **1408** is closed to cover at least a portion of the implant **1400**, the implant **1400** may be repositioned to some extent in some applications. In one technique, pressure is applied to the implant **1400** to move the implant into alignment with the reference point **1412**. The pressure may be applied to the anterior surface of the cornea **1404** proximate an edge of the implant **1400** (e.g., directly above, above and outside a projection of the outer periphery of the implant **1400**, or above and inside a projection of the outer periphery of the implant **1400**). This may cause the implant to move slightly away from the edge proximate which pressure is applied. In another technique, pressure is applied directly to the implant. The implant **1400**

may be repositioned in this manner if the reference point **1412** was marked on the flap **1408** or if the reference point **1412** was marked on the tissue bed. Preferably, pushing is accomplished by inserting a thin tool under the flap or into the pocket and directly moving the inlay.

[0244] FIG. 53 shows that a patient may also be treated by a method that positions an implant **1500** in a cornea **1504**, e.g., in a corneal pocket **1508**. Any suitable tool or technique may be used to create or form the corneal pocket **1508**. For example, a blade (e.g., a microkeratome), a laser, or an electrosurgical tool could be used to create or form a pocket in the cornea **1504**. A reference point **1512** is identified on the cornea **1504**. The reference point may be identified by any suitable technique, such as those discussed herein. The reference point **1512** is marked by any suitable technique, such as those discussed herein. The corneal pocket **1508** is created to expose an intracorneal surface **1516**. The corneal pocket **1508** may be created at any suitable depth, for example at a depth within a range of from about 50 microns to about 300 microns from the anterior surface of the cornea **1504**. The implant **1500** is positioned on the intracorneal surface **1516**. The marked reference point **1512** is helpful in positioning the implant **1500** on the intracorneal surface **1516**. The marked reference point **1512** enables the implant **1500** to be positioned with respect to the visual axis of the eye, as discussed above. In the illustrated embodiment, the implant **1500** is positioned so that a centerline M_{CL} of the implant **1500** extends through or adjacent to the marked reference point **1512**.

[0245] FIG. 53A illustrates another technique wherein a reference **1512'** is a ring or other two dimensional mark. In such a case, the implant **1500** may be placed so that an outer edge of the implant and the ring correspond, e.g., such that the ring and the implant **1500** share the same or substantially the same center. Preferably, the ring and the implant **1500** are aligned so that the centerline of the implant M_{CL} is on the line of sight of the eye, as discussed above. The ring is shown in solid lines because in the illustrated embodiment, it is formed on the anterior surface of the cornea **1504** above the pocket **1508**.

[0246] After the implant **1500** is positioned in the pocket **1508**, the implant **1500** may be repositioned to some extent in some applications. In one technique, pressure is applied to the implant **1500** to move the implant into alignment with the reference point **1512**. The pressure may be applied to the anterior surface of the cornea **1504** proximate an edge of the implant **1500** (e.g., directly above, above and outside a projection of the outer periphery of the implant **1500**, or above and inside a projection of the outer periphery of the implant **1500**). This may cause the implant **1500** to move slightly away from the edge at which pressure is applied. In another technique, pressure is applied directly to the implant **1500**.

[0247] The various methods and techniques described above provide a number of ways to carry out the invention. Of course, it is to be understood that not necessarily all objectives or advantages described may be achieved in accordance with any particular embodiment described herein. Thus, for example, those skilled in the art will recognize that the devices may be made that achieve or optimize one advantage or group of advantages as taught herein without necessarily achieving other objectives or advantages as may be taught or suggested herein.

[0248] Furthermore, the skilled artisan will recognize the interchangeability of various features from different embodiments. Similarly, the various features and steps discussed above, as well as other known equivalents for each such feature or step, can be mixed and matched by one of ordinary skill in this art to perform methods in accordance with principles described herein.

[0249] Although the invention has been disclosed in the context of certain embodiments and examples, it will be understood by those skilled in the art that the invention extends beyond the specifically disclosed embodiments to other alternative embodiments and/or uses and obvious modifications and equivalents thereof. Accordingly, the invention is not intended to be limited by the specific disclosures of preferred embodiments herein, but instead by reference to claims attached hereto.

What is claimed is:

1. A mask configured to be implanted in a cornea of a patient, the mask comprising:

a body formed from a polymeric material, the body having a light transmitting portion, a light blocking portion disposed about the light transmitting portion, an outer periphery surrounding the light blocking portion, an anterior surface, and a posterior surface, the anterior surface configured to reside adjacent a first intracorneal layer, the posterior surface configured to reside adjacent a second intracorneal layer, wherein the polymeric material includes one or more polyanionic compounds loaded into the polymeric material.

2. The mask of claim 1, wherein the total weight of the one or more polyanionic compounds is about 5% by weight to about 20% by weight.

3. The mask of claim 1, wherein the total weight of the one or more polyanionic compounds is about 12% by weight to about 17% by weight.

4. The mask of claim 1, wherein the one or more polyanionic compounds comprise proteoglycans or glycosaminoglycans.

5. The mask of claim 1, wherein the one or more polyanionic compounds includes at least one compound selected from the group consisting of dermatan sulfate, chondroitin sulfate, keratan sulfate, heparan sulfate, heparin, dextran sulfate, hyaluronic acid, pentosan polysulfate, xanthan, carrageenan, fibronectin, laminin, chondronectin, vitronectin, poly L-lysine salts, and alginate.

6. The mask of claim 1, wherein the one or more polyanionic compounds comprises dextran sulfate.

7. The mask of claim 1, wherein the polymeric material comprises a highly fluorinated polymeric material.

8. The mask of claim 7, wherein the highly fluorinated polymeric material comprises polyvinylidene fluoride (PVDF).

9. The mask of claim 1, wherein the material forming the light blocking portion of the body comprises an opacification agent selected from the group consisting of organic dyes, organic pigments, inorganic dyes, and inorganic pigments.

10. The mask of claim 9, wherein the opacification agent comprises carbon.

11. The mask of claim 10, further comprising at least one wound healing modulator compound.

12. The mask of claim 11, wherein at least a portion of the wound healing modulator compound is adsorbed to the carbon.

13. The mask of claim 11, wherein the wound healing modulator compound is selected from the group consisting of antibiotics, antineoplastics, antimetabolites, antimetabolites, anti-inflammatories, immunosuppressants, and antifungals.

14. The mask of claim 13, wherein the wound healing modulator compound is selected from the group consisting of fluorouracil, mitomycin C, paclitaxel, ibuprofen, naproxen, flurbiprofen, carprofen, suprofen, ketoprofen, and cyclosporins.

15. The mask of claim 1, wherein the light transmitting portion comprises a substantially circular aperture that is sized to transmit a fraction of the light incident on the anterior surface.

16. The mask of claim 1, wherein the body comprises a plurality of holes extending at least partially between the anterior surface and the posterior surface.

17. The mask of claim 1, wherein the polymeric material includes a UV absorbing component.

18. A mask configured to be implanted in a cornea of a patient, the mask comprising:

a body formed from a material comprising a highly fluorinated polymeric material, the body having a light transmitting portion, a light blocking portion disposed about the light transmitting portion, and outer periphery surrounding the light blocking portion, an anterior surface, and a posterior surface, the anterior surface configured to reside adjacent a first intracorneal layer, the posterior surface configured to reside adjacent a second intracorneal layer, wherein the material comprising a highly fluorinated polymeric material has loaded therein one or more polyanionic compounds.

19. The mask of claim 18, wherein the one or more polyanionic compounds comprise proteoglycans or glycosaminoglycans.

20. The mask of claim 18, wherein the one or more polyanionic compounds are selected from the group consisting of dermatan sulfate, chondroitin sulfate, keratan sulfate, heparan sulfate, heparin, dextran sulfate, hyaluronic acid, pentosan polysulfate, xanthan, carrageenan, fibronectin, laminin, chondronectin, vitronectin, poly L-lysine salts, and alginate.

21. The mask of claim 18, wherein the one or more polyanionic compounds comprises dextran sulfate.

22. The mask of claim 18, wherein the total weight of the one or more polyanionic compounds is about 10% by weight to about 20% by weight.

23. The mask of claim 18, wherein the highly fluorinated polymeric material comprises PVDF.

24. The mask of claim 18, wherein the material forming the light blocking portion of the body comprises an opacification agent selected from the group consisting of organic dyes, organic pigments, inorganic dyes, and inorganic pigments.

25. The mask of claim 24, wherein the opacification agent is carbon.

26. The mask of claim 25, further comprising at least one wound healing modulator compound.

27. The mask of claim 26, wherein at least a portion of the wound healing modulator compound is adsorbed to the carbon.

28. The mask of claim 26, wherein the wound healing modulator compound is selected from the group consisting of antibiotics, antineoplastics, antimetabolites, antimetabolites, anti-inflammatories, immunosuppressants, and antifungals.

29. The mask of claim 28, wherein the wound healing modulator compound is selected from the group consisting of fluorouracil, mitomycin C, paclitaxel, ibuprofen, naproxen, flurbiprofen, carprofen, suprofen, ketoprofen, and cyclosporins.

30. The mask of claim 18, wherein the light transmitting portion comprises a substantially circular aperture that is sized to transmit a fraction of the light incident on the anterior surface.

31. The mask of claim 18, wherein the material further comprises a second polymeric material.

32. The mask of claim 31, wherein the second polymeric material includes a UV absorbing component.

33. A mask comprising:

an aperture having a major axis of about 2.2 mm or less; and

an annular body extending between the aperture and an outer periphery of the mask, the annular body having an anterior surface and a posterior surface, the annular body being formed of a material comprising:

a highly fluorinated polymeric material;

an opacification agent, the opacification agent being present in sufficient quantity to prevent at least a substantial portion of light incident on the anterior surface from being transmitted from the anterior surface to the posterior surface; and

one or more polyanionic compounds and/or wound healing modulator compounds.

34. The mask of claim 33, wherein the total weight of the one or more polyanionic compounds is about 5% by weight to about 20% by weight.

35. The mask of claim 33, wherein the total weight of the one or more polyanionic compounds is about 12% by weight to about 17% by weight.

36. The mask of claim 33, wherein the one or more polyanionic compounds comprise proteoglycans or glycosaminoglycans.

37. The mask of claim 33, wherein the one or more polyanionic compounds are selected from the group consisting of dermatan sulfate, chondroitin sulfate, keratan sulfate, heparan sulfate, heparin, dextran sulfate, hyaluronic acid, pentosan polysulfate, xanthan, carrageenan, fibronectin, laminin, chondronectin, vitronectin, poly L-lysine salts, and alginate.

38. The mask of claim 33, wherein the one or more polyanionic compounds comprises dextran sulfate.

39. The mask of claim 33, wherein the highly fluorinated polymeric material comprises PVDF.

40. The mask of claim 33, wherein the opacification agent is selected from the group consisting of organic dyes organic pigments, inorganic dyes, and inorganic pigments.

41. The mask of claim 40, wherein the opacification agent is carbon.

42. The mask of claim 41, further comprising at least one wound healing modulator compound.

43. The mask of claim 42, wherein at least a portion of the wound healing modulator compound is adsorbed to the carbon.

44. The mask of claim 42, wherein the wound healing modulator compound is selected from the group consisting of antibiotics, antineoplastics, antimetabolites, anti-inflammatories, immunosuppressants, and antifungals.

45. The mask of claim 44, wherein the wound healing modulator compound is selected from the group consisting of fluorouracil, mitomycin C, paclitaxel, ibuprofen, naproxen, flurbiprofen, carprofen, suprofen, ketoprofen, and cyclosporins.

46. The mask of claim 33, wherein the anterior surface is configured to reside adjacent a first intracorneal layer of a cornea, and the posterior surface is configured to reside adjacent a second intracorneal layer.

47. The mask of claim 46, wherein the mask does not substantially alter the curvature of a cornea following application of the mask to a cornea.

48. The mask of claim 33, wherein the annular body has a substantially constant thickness between the anterior and posterior surfaces.

49. The mask of claim 33, wherein the annular body has a thickness between the anterior and posterior surfaces of about 20 microns or less.

50. The mask of claim 33, wherein the annular body has a thickness between the anterior and posterior surfaces of about 8 microns.

51. A mask configured to be implanted in a cornea of a patient, the mask comprising:

a body formed from a polymeric material, the body having a light transmitting portion, a light blocking portion disposed about the light transmitting portion, an outer periphery surrounding the light blocking portion, an anterior surface configured to reside adjacent a first intracorneal layer, a posterior surface configured to reside adjacent a second intracorneal layer, and at least one wound healing modulator loaded in the polymeric material and/or bound to at least one of the anterior surface and the posterior surface.

52. The mask of claim 51, wherein at least the light blocking portion comprises carbon.

53. The mask of claim 52, wherein at least a portion of the wound healing modulator compound is adsorbed to the carbon.

54. The mask of claim 51, wherein the wound healing modulator compound is selected from the group consisting of antibiotics, antineoplastics, antimetabolites, anti-inflammatories, immunosuppressants, and antifungals.

55. The mask of claim 54, wherein the wound healing modulator compound is selected from the group consisting of fluorouracil, mitomycin C, paclitaxel, ibuprofen, naproxen, flurbiprofen, carprofen, suprofen, ketoprofen, and cyclosporins.

56. The mask of claim 51, wherein the polymeric material is UV-resistant and/or includes a UV absorbing component.

57. The mask of claim 56, wherein the polymeric material comprises a highly fluorinated polymeric material.

58. The mask of claim 57, wherein the highly fluorinated polymeric material comprises polyvinylidene fluoride (PVDF).

59. The mask of claim 51, wherein the light transmitting portion comprises a substantially circular aperture that is sized to transmit a fraction of the light incident on the anterior surface.

60. The mask of claim 51, wherein the body comprises a plurality of holes extending at least partially between the anterior surface and the posterior surface.

61. The mask of claim 51, wherein polymeric material comprises one or more polyanionic compounds.

62. The mask of claim 61, wherein the total weight of the one or more polyanionic compounds is about 5% by weight to about 20% by weight.

63. The mask of claim 61, wherein the one or more polyanionic compounds comprise proteoglycans or glycosaminoglycans.

64. The mask of claim 61, wherein the one or more polyanionic compounds includes at least one compound selected from the group consisting of dermatan sulfate,

chondroitin sulfate, keratan sulfate, heparan sulfate, heparin, dextran sulfate, hyaluronic acid, pentosan polysulfate, xanthan, carrageenan, fibronectin, laminin, chondronectin, vitronectin, poly L-lysine salts, and alginate.

65. The mask of claim 61, wherein the one or more polyanionic compounds comprises dextran sulfate.

* * * * *