

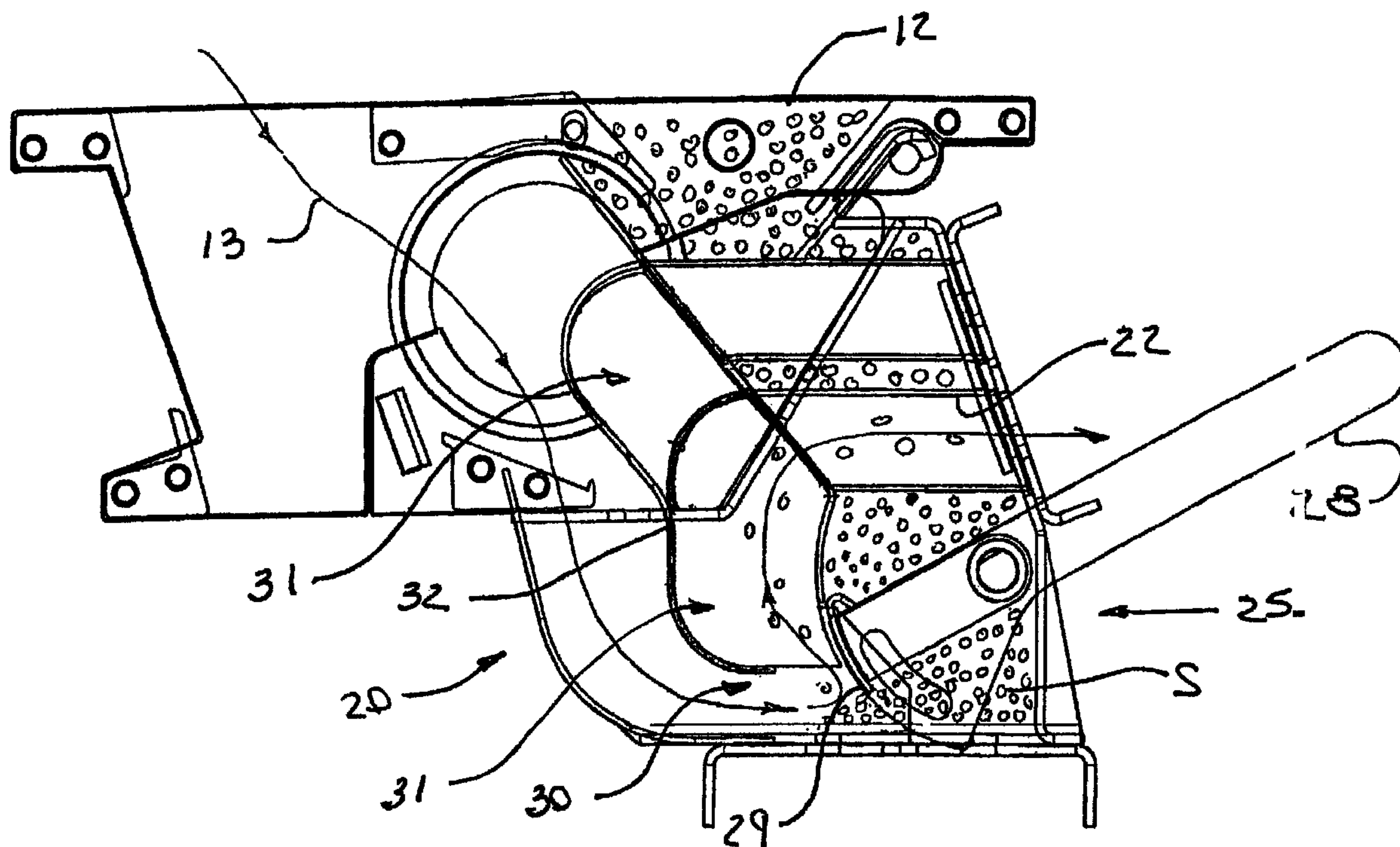

(22) Date de dépôt/Filing Date: 1999/11/04  
 (41) Mise à la disp. pub./Open to Public Insp.: 2000/05/05  
 (45) Date de délivrance/Issue Date: 2007/06/26  
 (30) Priorité/Priority: 1998/11/05 (US60/107,154)

(51) Cl.Int./Int.Cl. *A01C 7/20* (2006.01),  
*A01C 7/04* (2006.01), *A01C 7/10* (2006.01),  
*A01C 7/16* (2006.01)  
 (72) Inventeurs/Inventors:  
 MAYERLE, DEAN JAY, CA;  
 HUNDEBY, DAVID ROBERT, CA;  
 ENGEN, RONALD NATHANIEL, CA;  
 NEUFELD, GEORGE, CA  
 (73) Propriétaire/Owner:  
 CNH CANADA, LTD./CNH CANADA, LTEE, CA  
 (74) Agent: GOWLING LAFLEUR HENDERSON LLP

(54) Titre : DOSEUR POUR UNITE D'ADMISSION D'UN RAVITAILLEUR DE SEMOIR PNEUMATIQUE  
 (54) Title: REGULATOR FOR NURSE INDUCTION UNIT ON AIR SEEDERS



(57) **Abrégé/Abstract:**

A regulator for a nurse inductor mechanism on an agricultural seeding implement controls the rate of entrainment of seeds into the stream of air directed into the nurse inductor mechanism. The regulator includes a pivoted gate mounted at the discharge opening of the seed reservoir of the nurse induction unit to control the flow of seed particles into a pile for engagement with the stream of air directed thereto. An actuation lever, positioned externally of the nurse inductor housing so as to not interfere with the sealed relationship between the divider walls of the distribution apparatus and the housing, is selectively manipulable to move the pivoted gate between closed and opened positions. Once the pivoted gate is moved into the closed position, the flow of seed particles into the distribution apparatus is halted, but the full flow of air can still move through the distribution apparatus and seed distribution tubes to effect a clean-out of the nurse induction unit.

**REGULATOR FOR NURSE INDUCTION UNIT ON AIR SEEDERS**  
**ABSTRACT OF THE INVENTION**

5           A regulator for a nurse inductor mechanism on an agricultural seeding  
implement controls the rate of entrainment of seeds into the stream of air  
directed into the nurse inductor mechanism. The regulator includes a pivoted  
gate mounted at the discharge opening of the seed reservoir of the nurse  
induction unit to control the flow of seed particles into a pile for engagement  
10 with the stream of air directed thereto. An actuation lever, positioned  
externally of the nurse inductor housing so as to not interfere with the sealed  
relationship between the divider walls of the distribution apparatus and the  
housing, is selectively manipulable to move the pivoted gate between closed  
and opened positions. Once the pivoted gate is moved into the closed position,  
15 the flow of seed particles into the distribution apparatus is halted, but the full  
flow of air can still move through the distribution apparatus and seed  
distribution tubes to effect a clean-out of the nurse induction unit.

## REGULATOR FOR NURSE INDUCTION UNIT ON AIR SEEDERS

### BACKGROUND OF THE INVENTION

This invention relates generally to air seeders for planting seeds in the  
5 ground in an agricultural environment and, more specifically, to a nurse  
inductor system co-operable with a planter mechanism to feed seed or other  
particulate material to a planting mechanism for insertion of that material into  
the ground.

As the size of agricultural implements continues to grow, the versatility  
10 of such implements becomes more significant. Large air seeders have become  
increasingly popular for the planting of seeds, fertilizer and other product  
without strict regard for the exact placement of the seeds particles. For crop  
planting operations that require seed singulation, nurse systems are used to feed  
seed or other particles from larger hoppers into smaller reservoirs located at the  
15 singulators. A nurse inductor system enables an air cart typically used for  
dryland farming, (cereal crops, etc.), to be adapted for use in row crop planting  
applications, such as corn and soybean, though not limited to soybean and corn.  
A nurse inductor system can be used to enable a farmer to singulate on-row,  
with one central hopper filling location, and to plant more acres before having  
20 to stop to fill the central hopper again, resulting in quicker planting and less  
labor, while maintaining the precision spacing available by on-row singulation.

In U. S. Patent No. 5,161,473, a nurse system is disclosed which works  
off a specialized cart. The air comes into the seed delivery area coaxial with  
the seed tube that takes the air and seed to the row units. With this system  
25 substantial energy is used to nurse the seed since the air changes direction  
abruptly. This particular nurse system provides a dedicated fan to feed the 12  
rows to be planted from the nurse system. This system requires the adding or  
removing of shims to adjust line length, which is difficult and inconvenient to  
accomplish. U. S. Patent No. 5,156,102 and U. S. Patent No. 4,060,181 teach

other nurse embodiments.

## SUMMARY OF THE INVENTION

It is an object of this invention to provide a nurse inductor system operable for use with planters requiring singulation of the seeds for planting in  
5 the ground.

It is a feature of this invention that the nurse inductor system enables the use of an existing air cart for nursing seeds to individual planter units in a passive manner.

It is an advantage of this invention that the nursing system would not  
10 require the addition of active controls for the nurse induction mechanism, the system being self-regulating without any external electronic control systems being necessary.

It is another feature of this invention that replacement of existing components on a conventional air cart with nurse induction components, to  
15 convert the standard air cart without requiring permanent modifications to the cart.

It is another advantage of this invention that the induction of seed or other particulate product is accomplished more evenly and consistently, thereby reducing the possibility of a plugging of the lines.

It is yet another feature of this invention that bridging in the hopper side  
20 of the induction unit is avoided by increasing the room for particulate material to flow.

It is still another advantage of this invention that the air pressure and flow required by the nurse induction system is reduced, so that an existing fan  
25 on an air cart can be used for both nurse induction of seeds and the application of particles from one of more other air cart hopper(s) at the same time.

It is still another feature of this invention that the wings of the planter toolbar can be folded vertically without the need to empty particles out of the

planter seed reservoir before folding.

It is yet another advantage of this invention that the planter toolbar can be folded with the wings pivoted closer to the first row unit on the wing section of the planter row unit without interference between the planter seed reservoirs.

5 It is yet another advantage of this invention that more than one planter singulator can be fed with one nurse inductor line, thus enabling the development of a wider planter toolbar with substantially more planter units than previously available.

10 It is a further advantage of this invention that the nurse inductor mechanism can be used on an air cart that may also be used in dryland farming.

It is another object of this invention to provide a regulator that is operable across the entire lateral width of the nurse induction unit to control the flow of seeds through all of the seed distribution tubes at the same time.

15 It is yet another feature of this invention that the regulator includes a pivoted gate that is mounted for movement between an opened and a closed position to control the flow of seed particles through the discharge opening of the nurse inductor reservoir.

20 It is still another feature of this invention that the movement of the pivoted gate into the closed position does not interfere with the stream of air being directed into the nurse inductor unit.

It is still a further advantage of this invention that the nurse induction unit can be cleaned out with the continued air flow after the regulator has been closed.

25 It is yet another feature of this invention that the regulator is provided with an actuation lever that can be selectively manipulated to control the operation of the regulator.

It is yet a further advantage of this invention that the positioning of the actuation lever outside of the nurse inductor housing does not disrupt the sealed

relationship of the distribution apparatus and the housing.

It is a further feature of this invention that the regulator can be adapted for remote control in a manner particularly advantageous with precision farming practices.

5 It is still a further object of this invention to provide nurse inductor mechanism for an agricultural seeding implement which is durable in construction, inexpensive of manufacture, carefree of maintenance, facile in assemblage, and simple and effective in use.

10 These and other objects, features and advantages can be accomplished according to the instant invention by providing a regulator for a nurse inductor mechanism on an agricultural seeding implement to control the rate of entrainment of seeds into the stream of air directed into the nurse inductor mechanism. The regulator includes a pivoted gate mounted at the discharge opening of the seed reservoir of the nurse induction unit to control the flow of  
15 seed particles into a pile for engagement with the stream of air directed thereto. An actuation lever, positioned externally of the nurse inductor housing so as to not interfere with the sealed relationship between the divider walls of the distribution apparatus and the housing, is selectively manipulable to move the pivoted gate between closed and opened positions. Once the pivoted gate is  
20 moved into the closed position, the flow of seed particles into the distribution apparatus is halted, but the full flow of air can still move through the distribution apparatus and seed distribution tubes to effect a clean-out of the nurse induction unit.

25

#### **BRIEF DESCRIPTION OF THE DRAWINGS**

The advantages of this invention will be apparent upon consideration of the following detailed disclosure of the invention, especially when taken in conjunction with the accompanying drawings wherein:

-5-

Figure 1 is a side elevational view of a typical air seeder mechanism on which a nurse induction mechanism incorporating the principles of the instant invention is mounted;

5 Figure 2 is a schematic cross-sectional view of the nurse induction system depicted in Figure 1, the arrows depicting the direction of air flow through the mechanism;

10 Figure 3 is an enlarged schematic cross-sectional view of the nurse induction mechanism shown in Figure 2 to depict the flow of air and seed through the uppermost seed distribution tubes leading to the planting mechanism, the arrows depicting the direction of air flow through the mechanism;

15 Figure 4 is an enlarged schematic cross-sectional view similar to that of Figure 3 except depicting the flow of air and seed through the lowermost seed distribution tubes to the corresponding planting mechanism, the arrows depicting the direction of air flow through the mechanism;

Figure 5 is a perspective view of the divider wall portion of the nurse induction apparatus to depict the divider walls separating the uppermost and lowermost seed distribution tubes;

20 Figure 6 is a perspective view of the particle hopper side of the nurse induction unit, with the exterior induction box wall removed, the nurse distribution lines being oriented in vertical pairs to leave open space between the lines for the particles to pass through;

Figure 7 is a perspective view of the outlet side of the nurse induction unit seen from the exterior of the apparatus;

25 Figure 8 is a front elevational view of a typical planting mechanism adapted for operative association with the nurse system depicted in Figure 1 and incorporating the principles of the instant receiver header invention, the side wings of the planting mechanism being folded upwardly relative to the

central section to place the planting mechanism in a transport position;

Figure 9 is a front elevational view of the planting mechanism depicted in Figure 8 except with the side wing sections being folded down into an operative position;

5 Figure 10 is an enlarged elevational view of the nurse system receiver apparatus corresponding to the circled mechanism within Figure 9;

Figure 11 is an enlarged perspective view of the nurse system receiver assembly;

10 Figure 12 is an enlarged front elevational view of the nurse system receiver assembly shown in Figure 11;

Figure 13 is an enlarged side elevational view of the nurse system receiver assembly shown in Figure 12;

Figure 14 is a perspective view of the nurse system receiver header assembly;

15 Figure 15 is a side elevational view of the nurse system receiver header assembly shown in Figure 14;

Figure 16 is a front elevational view of the nurse system receiver header assembly shown in Figure 14;

20 Figure 17 is a top plan view of the nurse system receiver header assembly shown in Figure 14; and

Figures 18 a – d are perspective, side and front elevational, and top plan views of the nurse system receiver header assembly vent.

#### **DETAILED DESCRIPTION OF THE PREFERRED EMBODIMENT**

25 Referring first to Figures 1 - 4, the principles of the nurse induction apparatus can best be seen. The nurse induction adapter is mounted on a conventional air seeder, air cart, and redirects the air stream 13 coming from the fan 11 in an air cart box 16 into a path that leads through the nurse inductor

-7-

20. The air stream is guided into a nozzle region 30 that directs the air along a flow path that tangentially engages a pile of seed particles S exiting the opening 19 at the bottom of the seed hopper 12. The turbulence of the blast of air from the nozzle 30 loosens the seed particles from this assemblage of seed particles S exiting the opening 19 in the bottom of the seed hopper 12, entraining the individual seed particles into the air stream as it follows a path to the distribution lines 22 above the seed particle pile. The individual seed particles remain suspended in the air stream where the air bleeds off and the individual seed particles fall by gravity into a second pile or mass at the planting mechanism.

As best seen in Figures 3 – 7, the air stream 13 through the nurse inductor apparatus 20 is split at the general location of the seed particle mass at the bottom of the central seed hopper 12 on the air cart 10 into individual sections 31 that are isolated by generally vertical walls 32. Each individual section 31 leads to a different seed distribution tube 22 and, ultimately, to a different receiver header 45 and associated receivers 40. The nurse inductor 20 induces seed particles into the air stream when and where there is demand for the particles. The demand for particles is controlled by the level of product in each respective receiver on the output end of the seed distribution tube. When the receiver 40 is full, air is restricted from escaping from the seed distribution tube by the massed seed particles within the seed distribution tube. As a result of the filled receiver 40, which prevents the passage of air there through, the air flow and air velocity reduce due to increased pressurization of the line. This resultant reduction in potential air pressure reduces the capacity of the flow of air to induce the seed particles into the corresponding seed distribution tube 22. Since the flow of air through the nurse inductor 20 is spread across the entire unit, the flow of air will tend to go to the lines that have open receivers because of the less airflow resistance.

The divider walls 32, that separate the air and entrained seed particle flows to each respective seed distribution tube 22, are sealed such that air cannot get into the seed distribution tubes 22 downstream of the pickup area. The sealed vertical walls 32 also prevent cross over of air and entrained seed to different seed distribution tubes 22. This division of airflow enhances operation since each line is operable to run at different times, depending on demand as represented by the massed seed particles in the output end of the seed distribution tubes 22.

The shape of the air and entrained seed particle flow path has an impact on the performance of the inductor. When the receiver 40 is filled to allow only a small volume of air to flow through the receiver, air alone is still capable of traveling through the lines, through the massed seed particles and past the seed particles at the vent. If seed particles were to be allowed to be induced into the lines with airflows that are less than carrying velocity, a blocking of the seed distribution tubes 22 can occur. This problem of blocking the seed distribution tube 22 can be avoided by forming the portion of the inductor structure, just above the area adjacent to the bottom of the central seed hopper where the individual seed particles are entrained into the airflow, larger so that the air velocity slows down in this region.

With the slowed air velocity, any seed particles that had been entrained into the slow flowing air stream fall out of the airflow and are dropped back into the seed particle mass region. Thus, the seed particles are picked up and carried by the air stream only when the air velocity is above the minimum carry velocity, thereby allowing air to be flowing slowly without transporting any entrained seed particles into the full seed distribution tube. Correspondingly, the cross-sectional area of the seed distribution tubes is smaller than the cross-sectional area between the generally vertical walls dividing the plenum into discreet channels. As a result, the air velocity increases once entering the

seed distribution tube, allowing the seed particle to be retained within the air stream once it enters the seed tube.

The regulator 25 for the flow of seed particles into the area for entrainment within the air stream is defined by a movable gate 29 forming a common edge along which seed particles flow into the particle pick-up area. The product regulator 25 extends across the entire nurse induction apparatus 20. As the seed particles flow under the product regulator, the seed particles form a pile falling naturally at the angle of repose of the seed particles. The angled surface of the pile of seed particles forms the bottom wall of the air channel in the pick-up area. The proximity of the air nozzle 30 to the wall of product affects the amount of product carried in the air stream. As the regulator 25 is rotated and more or less product is permitted to pass through the opening 19a at the bottom of the central seed hopper 12, the seed particles fall either closer to or farther from the air nozzle 30. Since different products, such as different seed types, have properties that affect how easily the air stream picks them up, as well as the differences in the angle of repose at which the products slump, the ideal distance between the product surface and the air nozzle varies with the product being distributed. The product regulator 25 is adjustable to enable the optimum distance to be set for each product type, as well as the desired flow rate.

As the air stream 13 strips the product away close to the bottom of the product regulator 25, product from the hopper 12 replenishes the created cavity. The closer to the bottom of the regulator 25 the product is stripped away, the more quickly the product is replenished. Thus, when the regulator 25 is positioned correctly for the specific type of product being nursed, the induction of product into the air stream is relatively steady. During testing, it was found that steady induction of product into the air stream reduced plugging problems within the distribution tubes 22 while maximizing product delivery efficiency.

The product regulator 25 is located on the hopper side of the induction box so that it does not interfere with the seal of the divider walls 32. The product regulator 25 is formed as a single crescent shaped plate 29 that extends across the entire width of the induction unit 20. The regulator plate 19 is  
5 attached to a shaft that is rotated by an external handle 28. Thus, the flow of product across the induction box is controlled with the adjustment of a single handle 28. As a result, the flow rate of seed particles can be controlled for all of the tubes 22 simultaneously, and can be completely shut-off to permit clean-out during which process the air will still be guided through the  
10 distribution tubes 22 without carrying seed particles. The rotatable regulator plate 19 can be adapted easily for remote control by appropriate actuators connected to the regulator 25. Such a configuration is particularly advantageous in precision farming practices, as the flow of seed particles through the seed distribution tubes 22 can be turned on and off easily.  
15 Alternatively, the regulator 25 could be configured to control the flow of air through the nozzle 30 instead of the flow of seeds.

The generally vertical divider walls 32 are constructed such that the nurse inductor apparatus is made in pair segments that are stacked to fit the width of the induction box. The vertical nature of this modular design allows  
20 the inductor apparatus to be compact. The modularity of such a design allows the nurse inductor to be easily adapted to different widths and numbers of product lines, including a compact induction box width having a large number of product lines. To allow more space on the particle hopper side of the inductor unit, the distribution tubes 22 forming the outlet pipes are stacked in  
25 vertical pairs. The additional space between outlet pipes reduces bridging of the particles as they flow past the pipes and into the region of the product regulator 25. Each distribution tube 22 is independent. The walls 32 dividing the distribution tubes are curved to direct the air and entrained seed particle

stream as shown in Figure 5. The air and entrained seed make relatively small directional changes in the inductor apparatus, which improves the efficiency of the air system. This efficiency enables both the nursing of more than 12 rows and the use of the second air cart tank for simultaneous fertilizer operations.

5           Alternatively, the nurse induction unit 20 is adaptable for use with a stand-alone tank, as well as for with an air cart. Furthermore, the nurse induction unit 20 can also be adaptable to other planter units. As best seen in Figures 1 and 2, the nurse induction apparatus is preferably formed as a modular unit that can be inserted into a standard air cart structure to convert the  
10           air cart from a straight meter box into a nurse induction box. The conventional air delivery tubes 17 are sealed and remain on the air cart 10, while the nurse induction unit 20 is interposed to receive the air stream 13 from the fan 11. A connection mechanism 16 facilitates the convenient connection of the nurse unit 20 to the air cart 10 as a modular component.

15           One skilled in the art will recognize that the instant invention is not limited to the conveyance of seed particles, as other particulate matter is commonly distributed through an air cart system, such as fertilizer. Furthermore, the typical air cart 10 is provided with multiple hoppers or tanks containing different product to be planted in the ground. One tank could have  
20           seed stored therein, while another tank would have fertilizer and yet another tank could have herbicides or still another reservoir of fertilizer. In such multi-tank configurations, one of the tanks could be provided with a nurse induction unit 20 to convey seeds to the planting devices, while a conventional meter box is used to control the flow of fertilizer or other product to the  
25           planting devices by separate distribution tubes. Such a conventional meter box could apply the fertilizer or other product at a variable rate and could be controlled by an electronic controller, as is known for precision farming techniques. Other alternative configurations can include one tank nursing seed

to all the singulators, as well as multiple tanks nursing seeds to any one particular singulator.

Referring now to Figures 8 – 18d, the nurse system receiver 40 and receiver header 45 can best be seen. The receiver 40 and receiver header 45 are used in conjunction with the nurse inductor system 20, such as the one described above. One skilled in the art will recognize that the header 45 is needed in configurations where the flow is to be split between multiple receivers. The nurse inductor 20 sends an air and entrained particle stream to the receiver 40 when the receiver has less than a desired level of product particles in it. The receiver header 45 is designed to allow air from the air and entrained product particle stream to escape when the particle level is below the air vent, but to limit the amount of air to escape when the particle level is above the air vent 50.

The receiver 40, as shown in Figures 11 – 13, provides a small mass of seeds in the location of the singulator pickup area 41. The seeds S are massed in the receiver 40 and in the line 42 from the receiver 40 up to the receiver header 45, which is the start of the leg 46 in the header Y. When the seeds are accumulated up to the top of the leg 46, they block the flow of air through the air vent 50 near the header bottom. When the air does not flow freely through the air vent 50, the flow of particles from the nurse inductor unit diminishes as described above. Only the small flow of air that can escape through the particles and vent 50 will continue to flow. This airflow is too low to entrain or pick-up particles.

If only one leg 46 of the Y is full, particles will continue to be nursed into the empty leg 47 until the air vent 50 is covered in the second leg 47 also. Then, the airflow to the header 45 will drop off and particles will not be sent in the nurse line 22 until such a time that one of the receivers 40 is emptied below the level where its air vent 50 is free. The nurse line 22 leading to the receiver

header 45 is smaller than the lines 42 between the header 45 and the receiver 40 to reduce the velocity of the air flow at the receiver header 45, thus allowing the entrained seed particle to drop out of the air stream and fall by gravity to the receiver 40. To stop blocking of particles in the nurse line 22, the receiver  
5 header 45 is mounted such that the inlet line 48 is always vertically above the outlet lines 42, regardless of the implement position. As best seen in Figures 8 – 10, the header 45 is mounted such that it sits at an angle inclined to the vertical in operating position. The mounting of the header 45 also permits the header 45 to be moved through vertical to an opposite angle to the vertical in  
10 the transport position, which typically involves the rotation of the header through an angle in the range of 70 to 110 degrees, or approximately 90 degrees. The header 45 never inverts to allow particles to flow out of it back down the nurse line 22 which would cause plugging. The header mount design enables folding of the planter P into transport with full receivers 40. The  
15 header 45 never inverts, so the seed particles S stay in the receivers 40 when the planter P is moved between transport and operative positions.

The vent hood 52 makes a roof over the vent 50 to allow the air to be vented out and guard against rain and contaminants getting in. The orientation of the receiver header 45 always keeps the hood 52 opening facing down, even  
20 when the toolbar is rotated into transport. Other embodiments may use receiver headers 45 that are single or triple, or other variations. It is also possible that the vent and rain guard may be incorporated directly into the receiver design if a separate header is not desirable. The single design would be mounted at an angle to provide a similar function to trap seed particles when moving into and  
25 out of transport. The single design would also preferably incorporate the vent and rain hood in a manner similar to the double configuration described above. Since the single configuration would feed only a single receiver, it would be desirable to mount the header directly onto the receiver or to incorporate the

header into the receiver design. The triple configuration would be similar to the double configuration described above with the addition of one single leg.

The nurse inductor 20 enables the use of a standard air cart 10 for both the central hopper and the nurse system air source. The air cart fan can be used for both fertilizing and nursing operations simultaneously. The inductor 20 can be designed in an adapter arrangement, which enables the air cart 10 to be readily converted from a roller type metering system to the nurse inductor system, and vice versa. The change to the cart to enable nurse induction is not permanent and does not require the use of time-consuming threaded fasteners.

It will be understood that changes in the details, materials, steps and arrangements of parts which have been described and illustrated to explain the nature of the invention will occur to and may be made by those skilled in the art upon a reading of this disclosure within the principles and scope of the invention. The foregoing description illustrates the preferred embodiment of the invention; however, concepts, as based upon the description, may be employed in other embodiments without departing from the scope of the invention.

20

25

## CLAIMS:

1. A regulator for a nurse induction unit having a reservoir for holding a supply of product to be distributed by the nurse induction unit, said reservoir including a discharge opening through which said product passes; a source of air flow into said nurse induction unit to entrain said product; and a distribution apparatus for distributing the flow of product entrained in said air flow, said distribution apparatus including multiple distribution outlets oriented along a lateral width of said nurse induction unit, comprising:
  - 10 a movable gate associated with said distribution apparatus to control the entrainment of said product into said air flow along a lateral width of said nurse induction unit corresponding to at least two of said distribution outlets.
2. The regulator of Claim 1 wherein said movable gate is positioned to limit the flow of air into said distribution apparatus.
3. The regulator of Claim 1 wherein said movable gate is positioned to limit the passage of product into said distribution apparatus.
- 20 4. The regulator of Claim 3 wherein said movable gate is rotatably mounted at said discharge opening for movement between opened and closed positions to control a rate of flow of product through said discharge opening.
5. The regulator of Claim 4 wherein the movement of said movable gate into said closed position allows the full flow of air to move into said distribution apparatus and out through said distribution outlets.
- 25 6. The regulator of Claim 5 wherein said movable gate is provided with an

actuation lever for effecting the movement thereof between said opened and closed positions.

7. The regulator of Claim 6 wherein said nurse induction unit further has a housing against which said distribution apparatus is sealed, said actuation lever being positioned externally of said housing so as to maintain the sealed relationship between said housing and said distribution apparatus when being manipulated to effect movement of said movable gate.

8. In a nurse induction unit having a reservoir for holding a supply of product to be distributed by the nurse induction unit, said reservoir including a discharge opening through which said product passes; a source of air flow into said nurse induction unit to entrain said product; and a distribution apparatus for distributing the flow of product entrained in said air flow, said distribution apparatus including multiple distribution outlets oriented along a lateral width of said nurse induction unit, the improvement comprising:

a regulator associated with said distribution apparatus to control the entrainment of said product into said air flow along a lateral width of said nurse induction unit corresponding to at least two of said distribution outlets.

9. The nurse induction unit of Claim 8 wherein said regulator includes a pivoted gate associated with said discharge opening to limit the passage of product into said distribution apparatus.

10. The nurse induction unit of Claim 9 wherein said pivoted gate is mounted for movement between opened and closed positions to control a rate of flow of product through said discharge opening, said product falling into a pile at a natural angle of repose to be engageable with said flow of air for

entrainment therein.

11. The nurse induction unit of Claim 10 wherein said regulator extends along the entire lateral width of said nurse induction unit.

5

12. The nurse induction unit of Claim 11 wherein said nurse induction unit further has a housing against which said distribution apparatus is sealed, said pivoted gate being provided with an actuation lever positioned externally of said housing for effecting the movement of said pivoted gate between said  
10 opened and closed positions.

13. The nurse induction unit of Claim 12 wherein the movement of said movable gate into said closed position allows the full flow of air to move into said distribution apparatus and out through said distribution outlets.

15

14. The nurse induction unit of Claim 13 wherein said distribution apparatus includes:

a divider corresponding to each said distribution outlet to isolate each respective said distribution outlet from the other distribution outlets, said  
20 dividers being sealed against said housing.

15. The nurse induction unit of Claim 14 wherein said distribution outlets are arranged in a generally vertically stacked paired configuration.

25 16. The nurse induction unit of Claim 15 wherein said distribution outlets pass through said reservoir and are sufficiently spaced to permit said product to pass between said discharge tubes.

-18-

17. A seeding implement comprising:

a mobile frame adapted for movement over the ground;

a mechanism mounted on said mobile frame for creating and channeling a stream of air;

5 a tank supported on said mobile frame for carrying a supply of seed particles, said tank having a discharge opening for the passage of said seed particles;

a nurse inductor mechanism mounted on said tank to receive seed particles therefrom and to receive said air stream, said nurse inductor mechanism including:

10 a reservoir for holding a supply of seeds particles to be distributed by the nurse induction unit, said reservoir being in flow communication with said tank to receive seed particles therefrom and including a discharge opening through which said seed particles pass to form a pile;

15 a nozzle for directing said stream of air into said nurse induction unit to create a turbulence at said pile of seed particles to entrain said seed particles into said stream of air; and

a distribution apparatus for distributing the flow of seed particles entrained in said stream of air, said distribution apparatus including multiple seed distribution outlets oriented along a lateral width of said nurse induction unit through which said seed entrained stream of air is discharged to carry said seed particles to a remote location, said distribution apparatus further including a plurality of divider walls isolating each respective said seed distribution outlet from each other seed distribution outlet; and

25 a regulator associated with said distribution apparatus to control the entrainment of said seed particles into said stream of air along the entire lateral width of said nurse induction unit.

18. The seeding implement of Claim 17 wherein said regulator includes a pivoted gate associated with said reservoir discharge opening to limit the passage of seed particles into said distribution apparatus, said pivoted gate being mounted for movement between opened and closed positions to control a rate of flow of product through said discharge opening.

19. The seeding implement of Claim 18 wherein said nurse induction unit further has a housing against which said divider walls are sealed, said pivoted gate including an actuation lever positioned externally of said housing for effecting the movement of said pivoted gate between said opened and closed positions.

20. The nurse induction unit of Claim 19 wherein the movement of said pivoted gate into said closed position allows the full flow of air to move into said distribution apparatus and out through said seed distribution outlets.

20

25

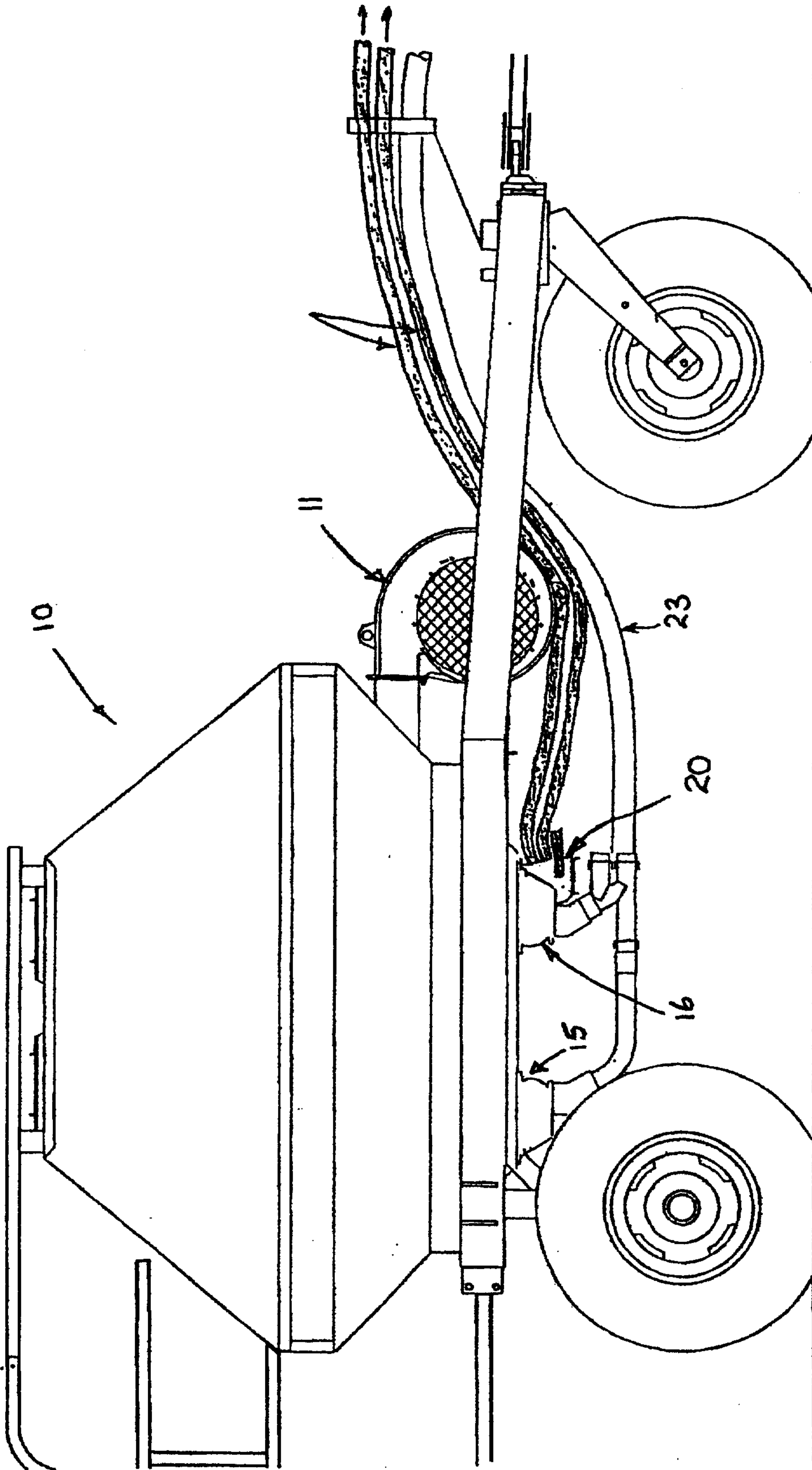

Figure 1

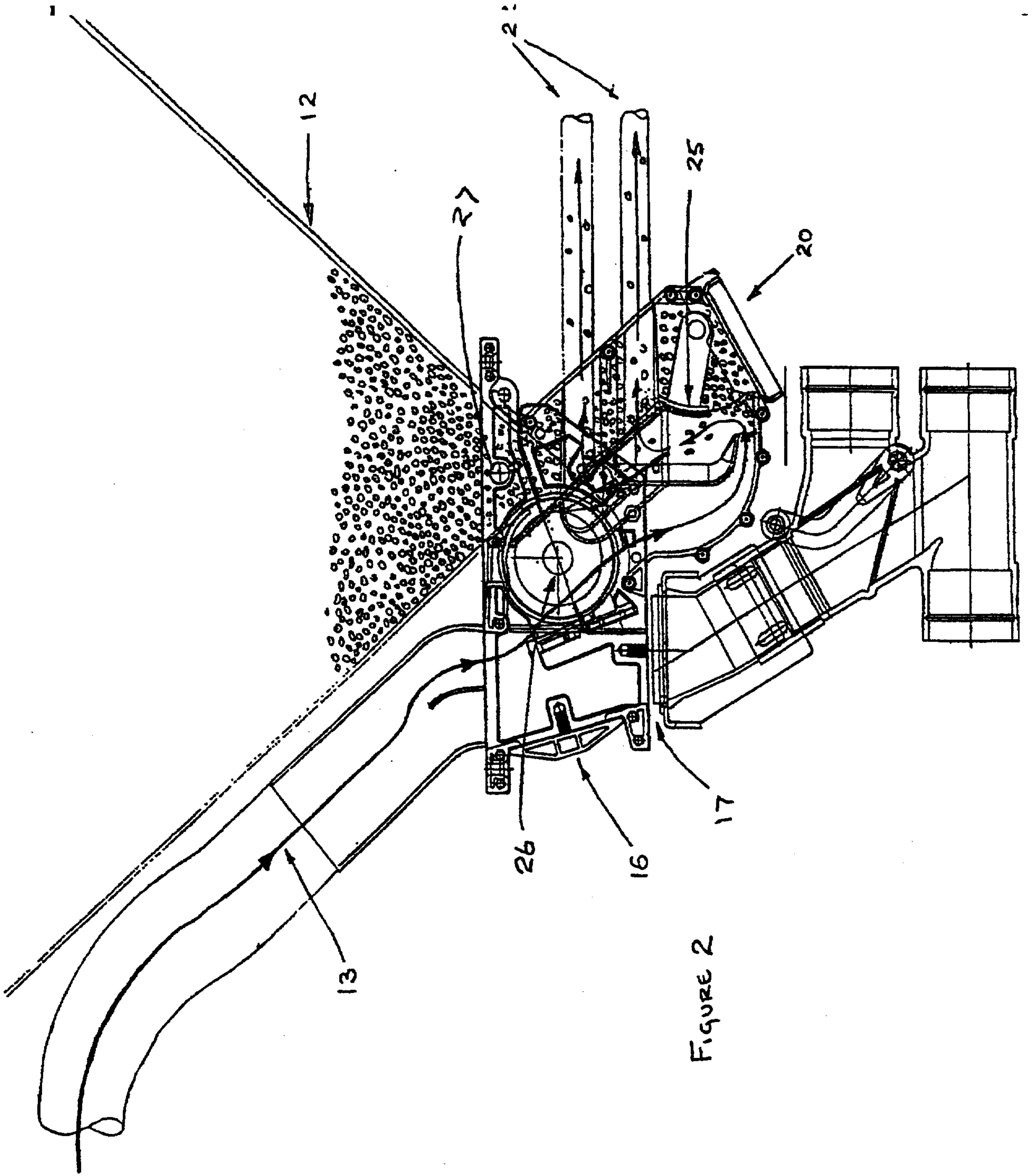

FIGURE 2

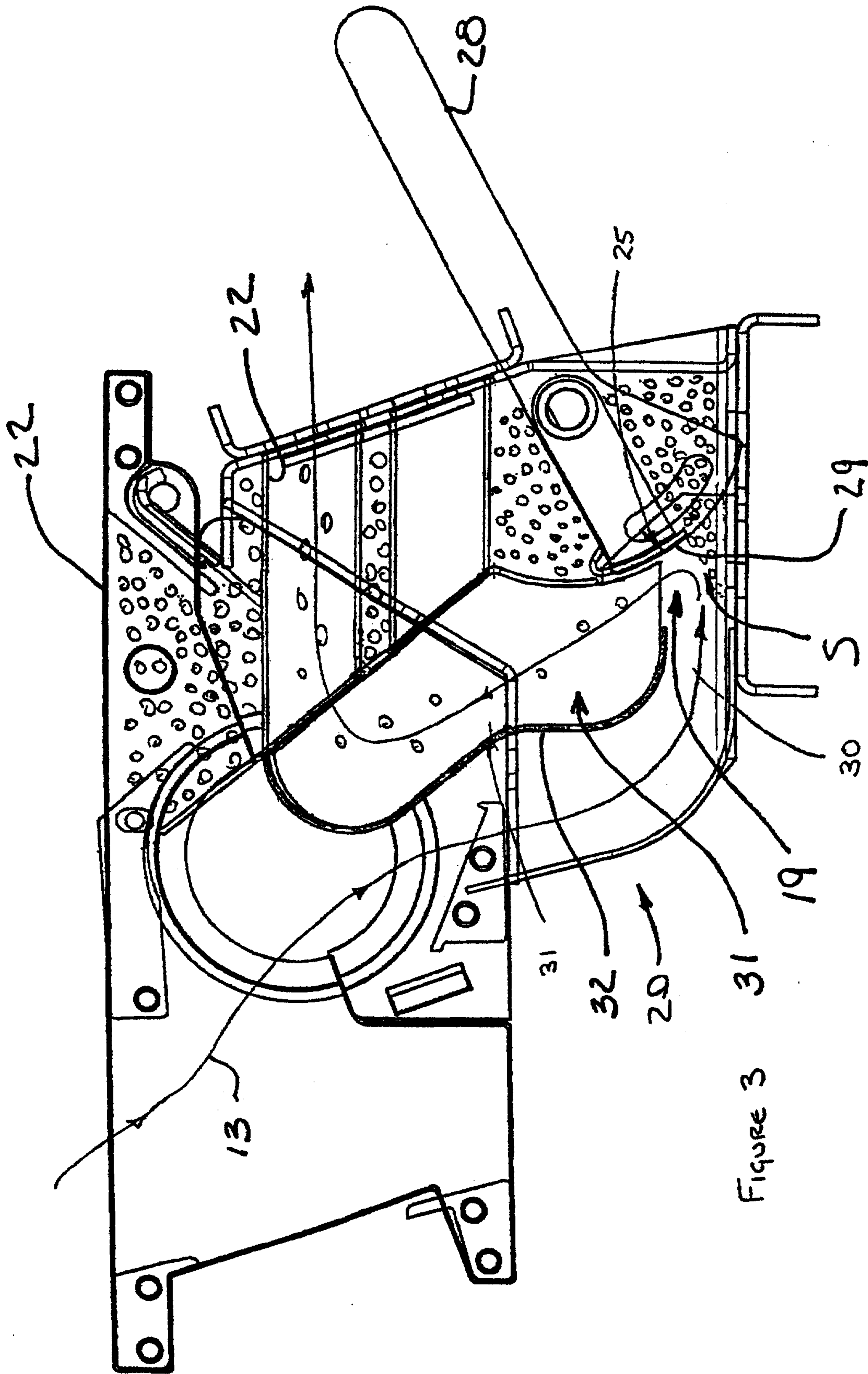

Figure 3

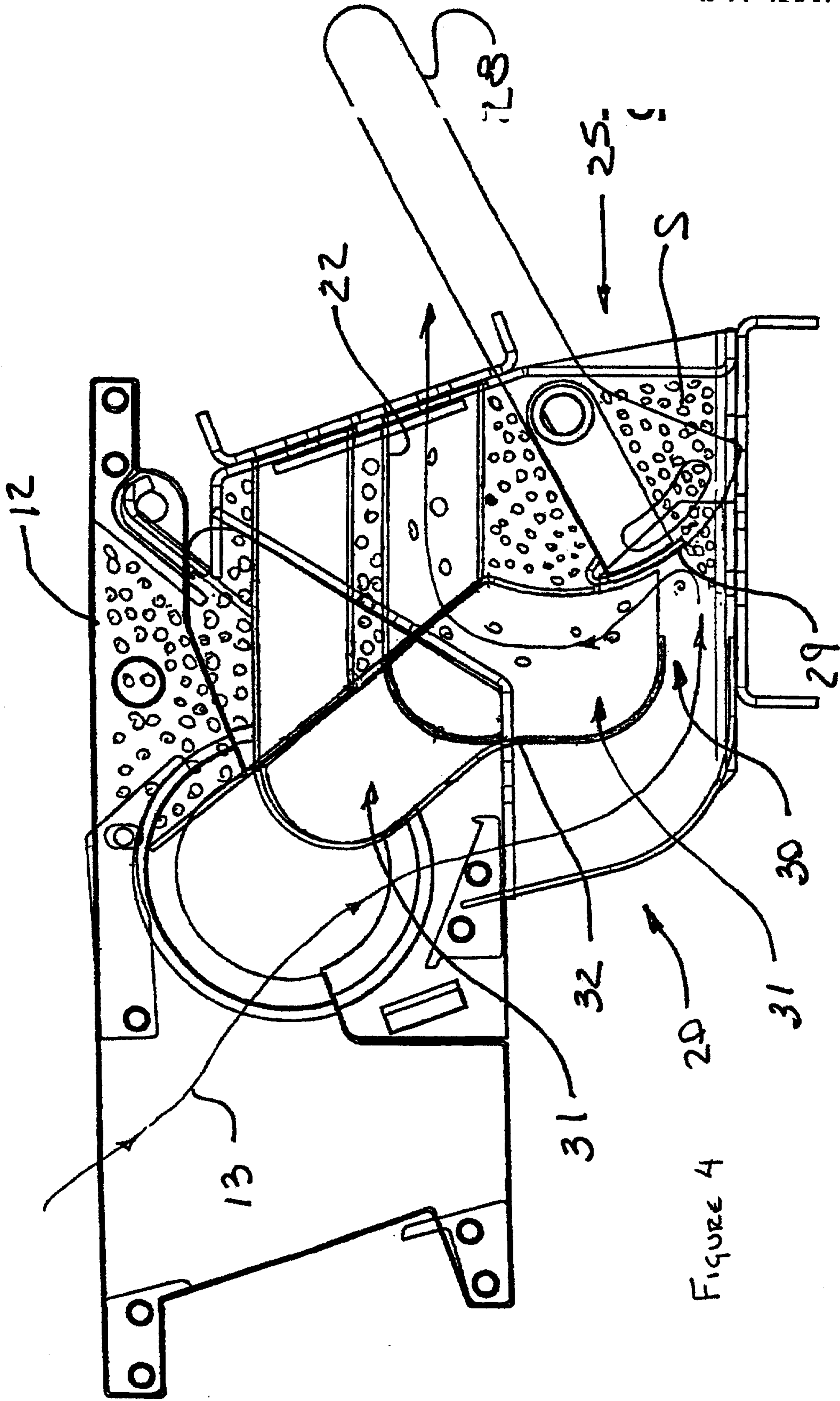

Figure 4

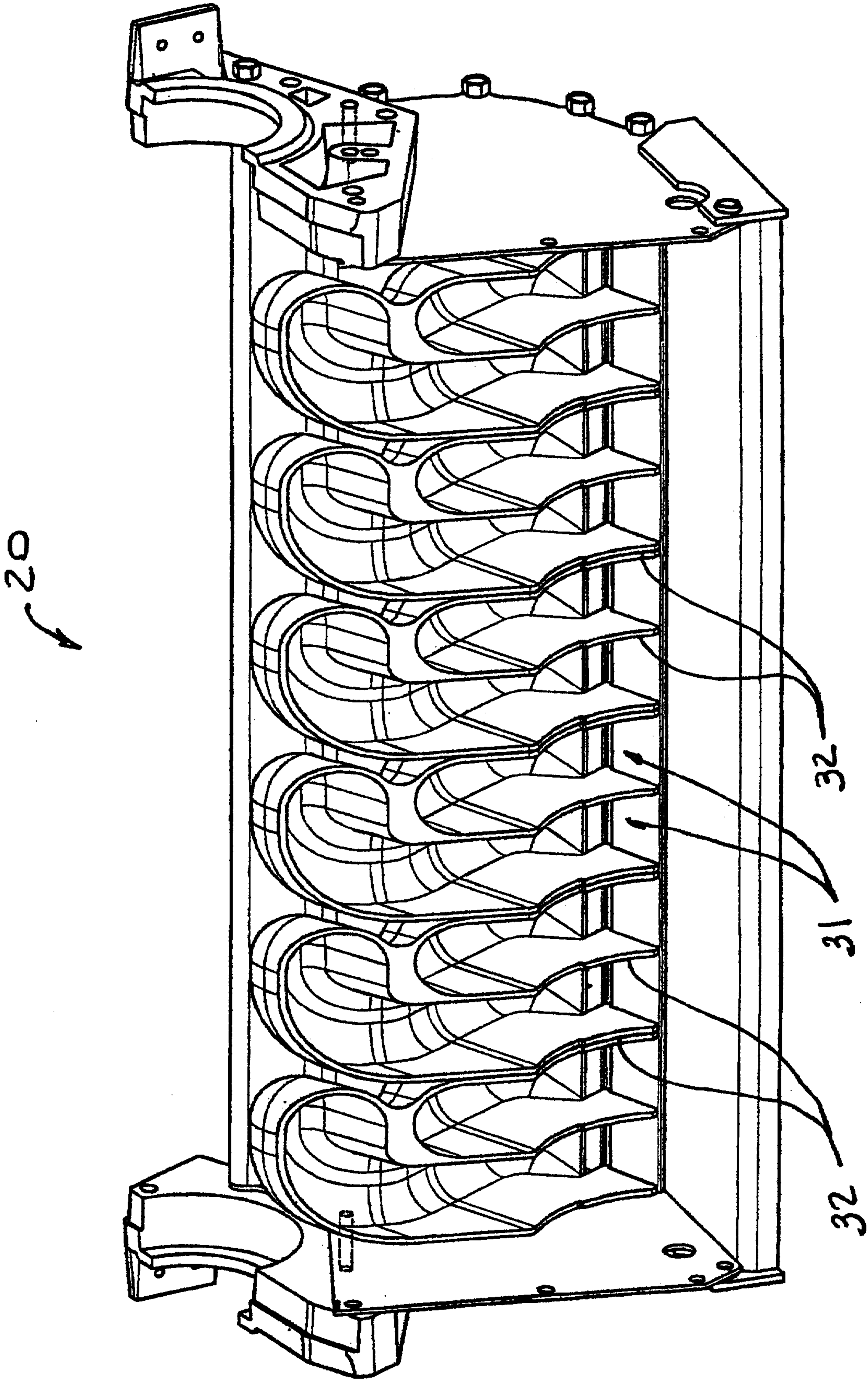

FIGURE 5

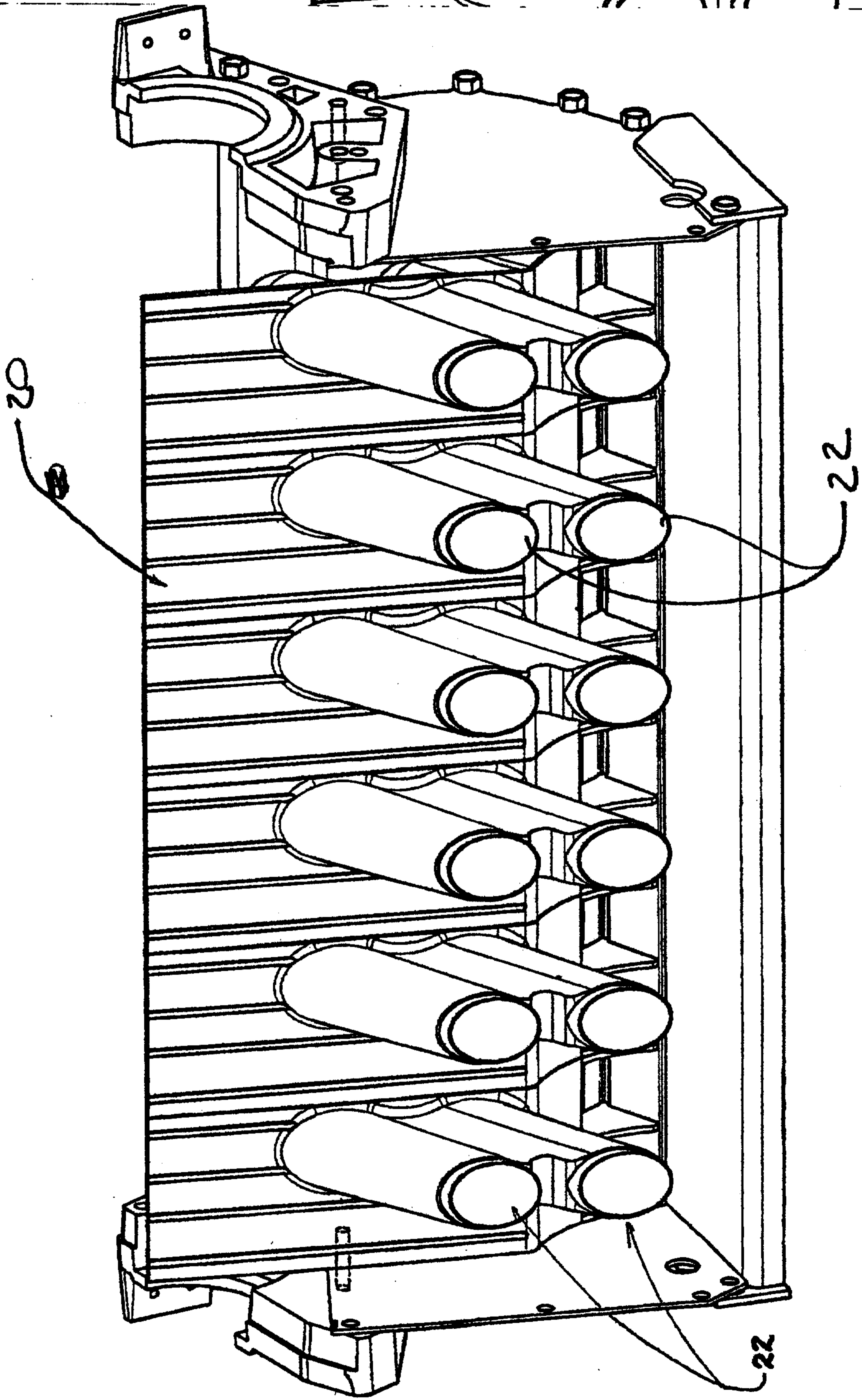

FIGURE 6

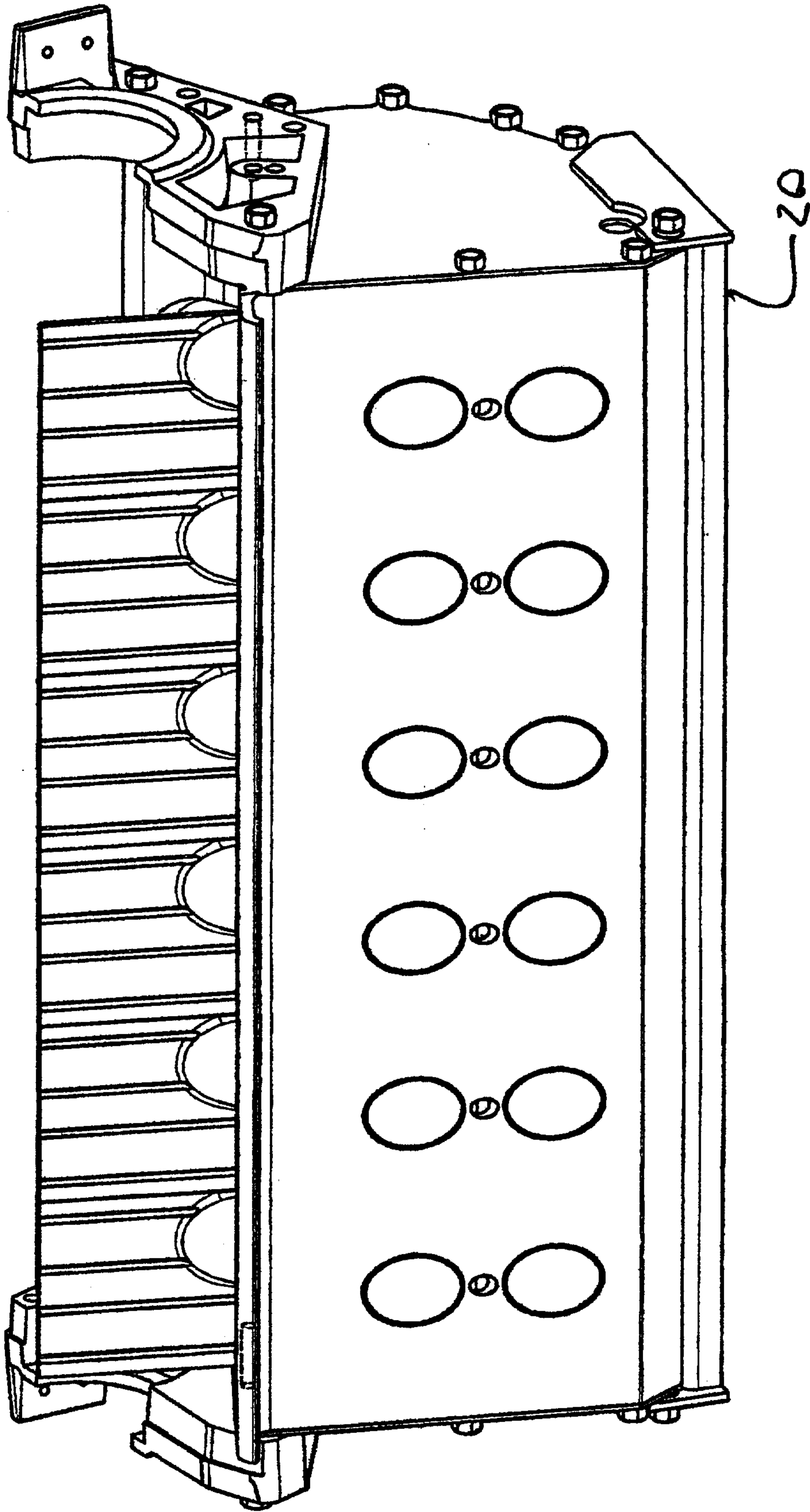

FIGURE 7

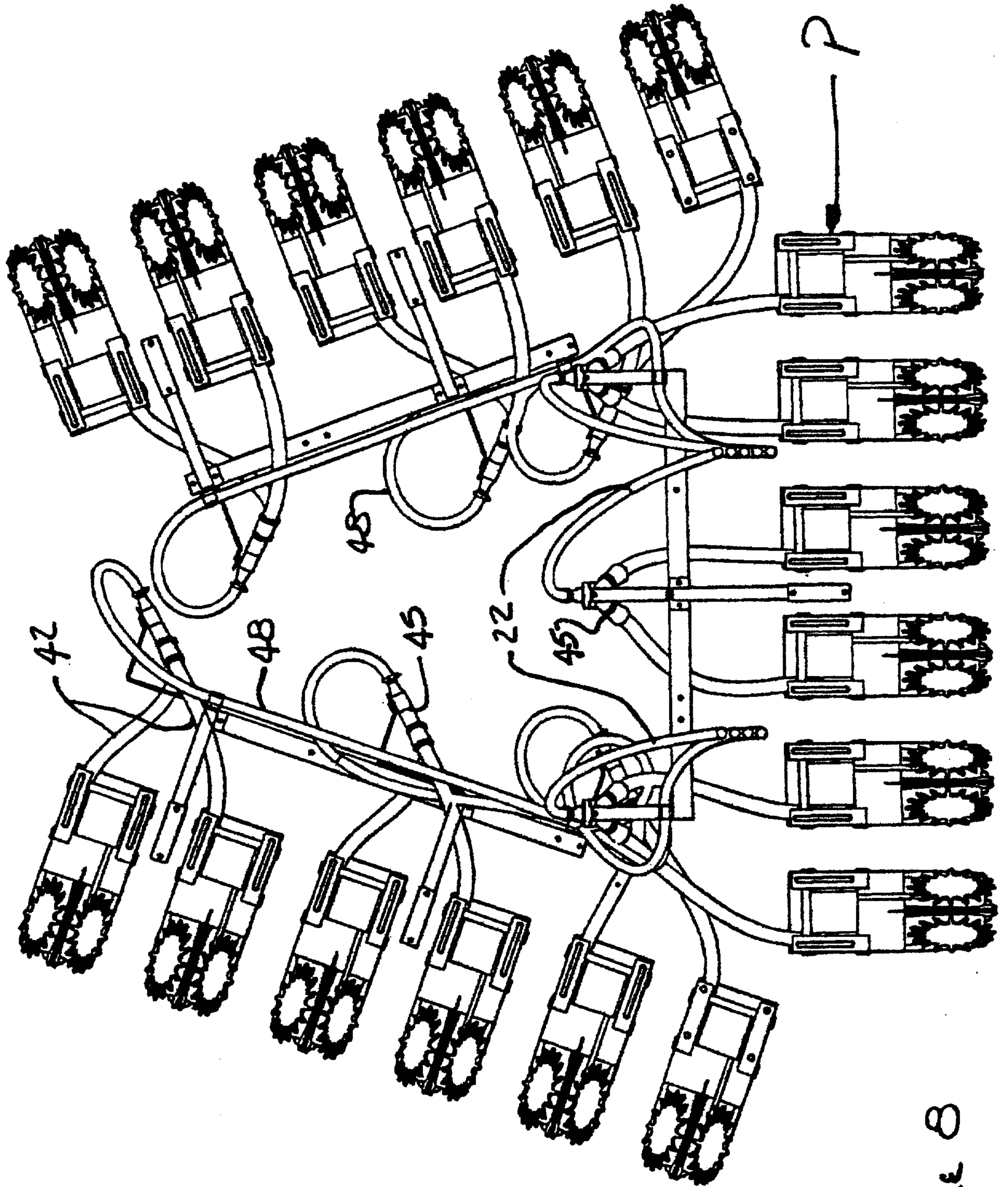

Figure 8

Figure 9

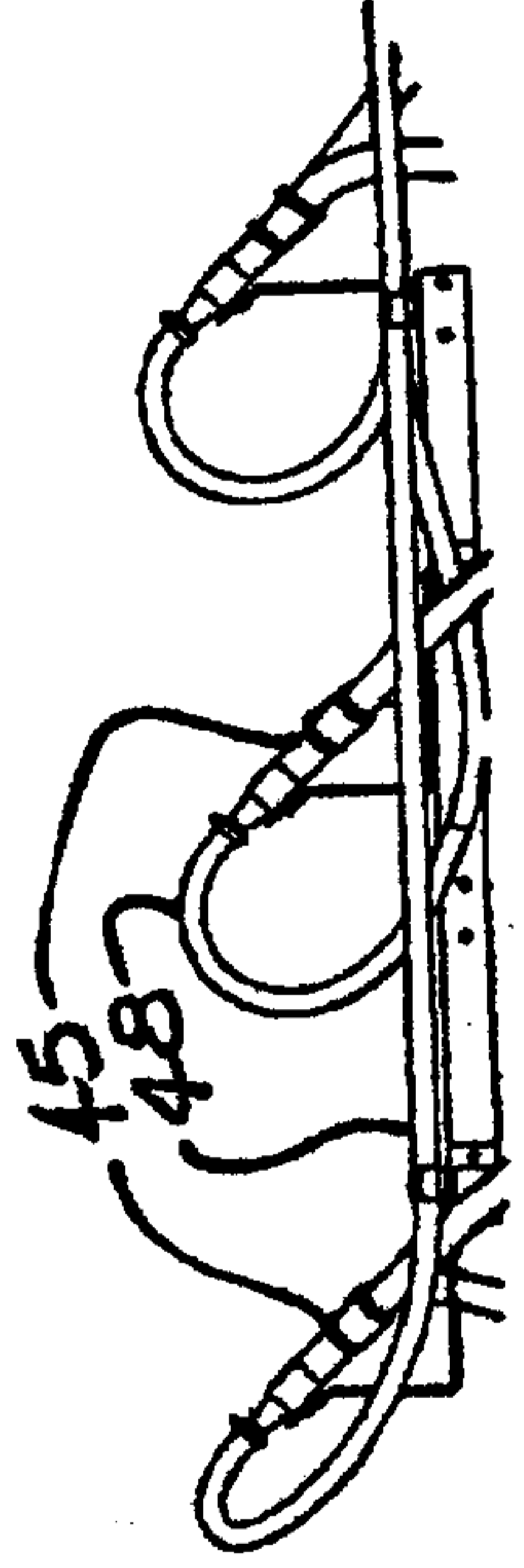
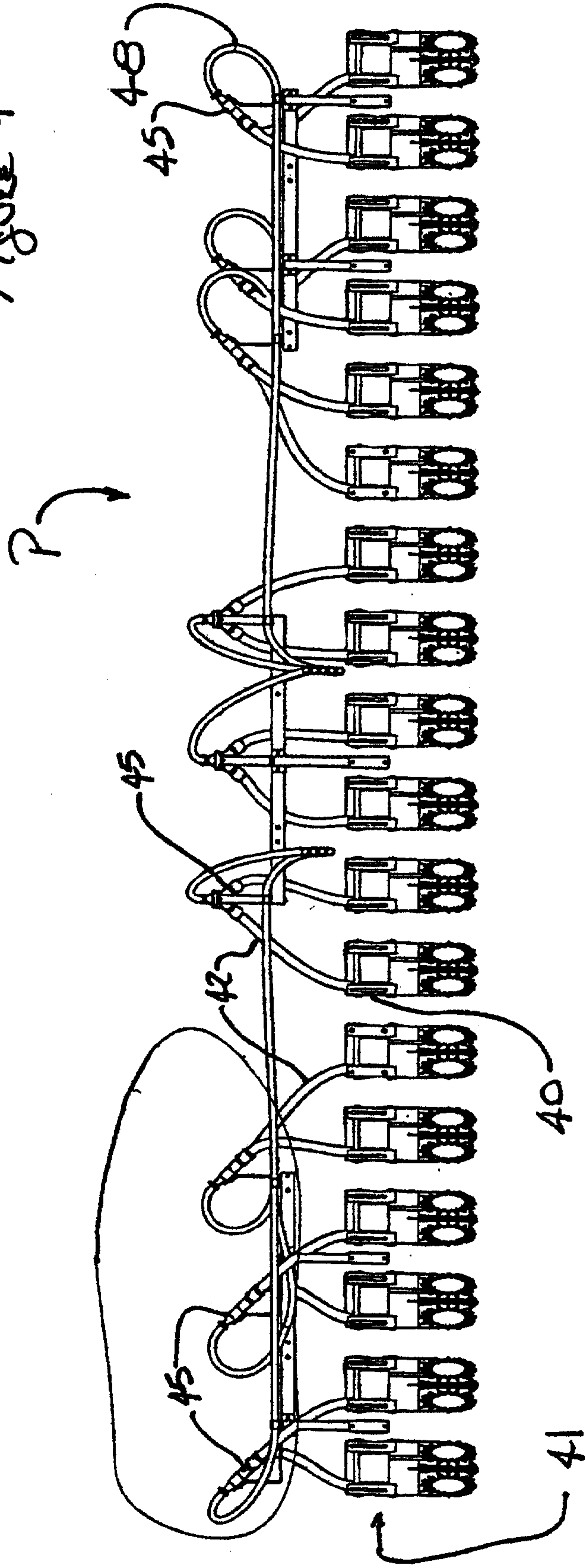

Figure 10

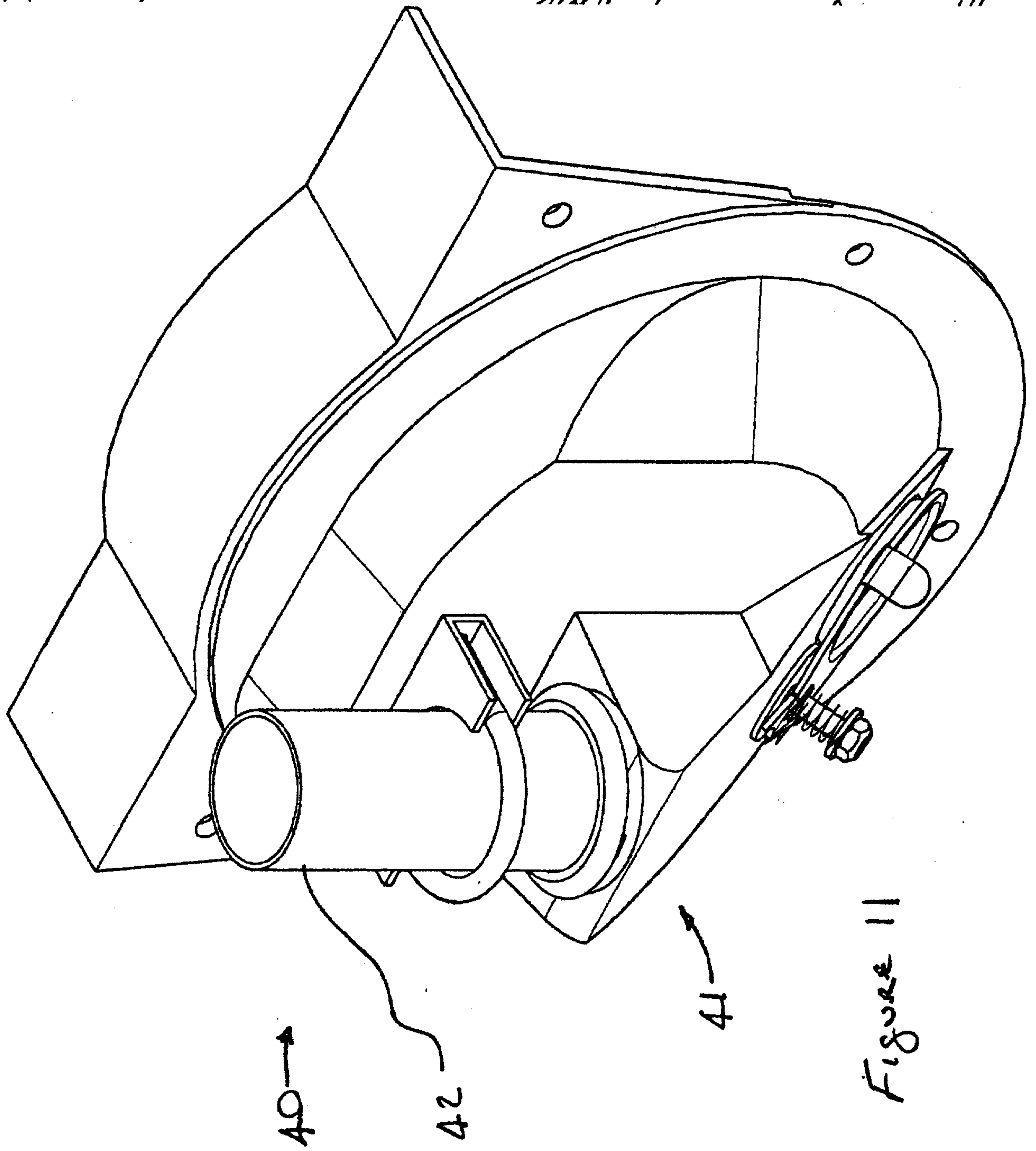

Figure 11

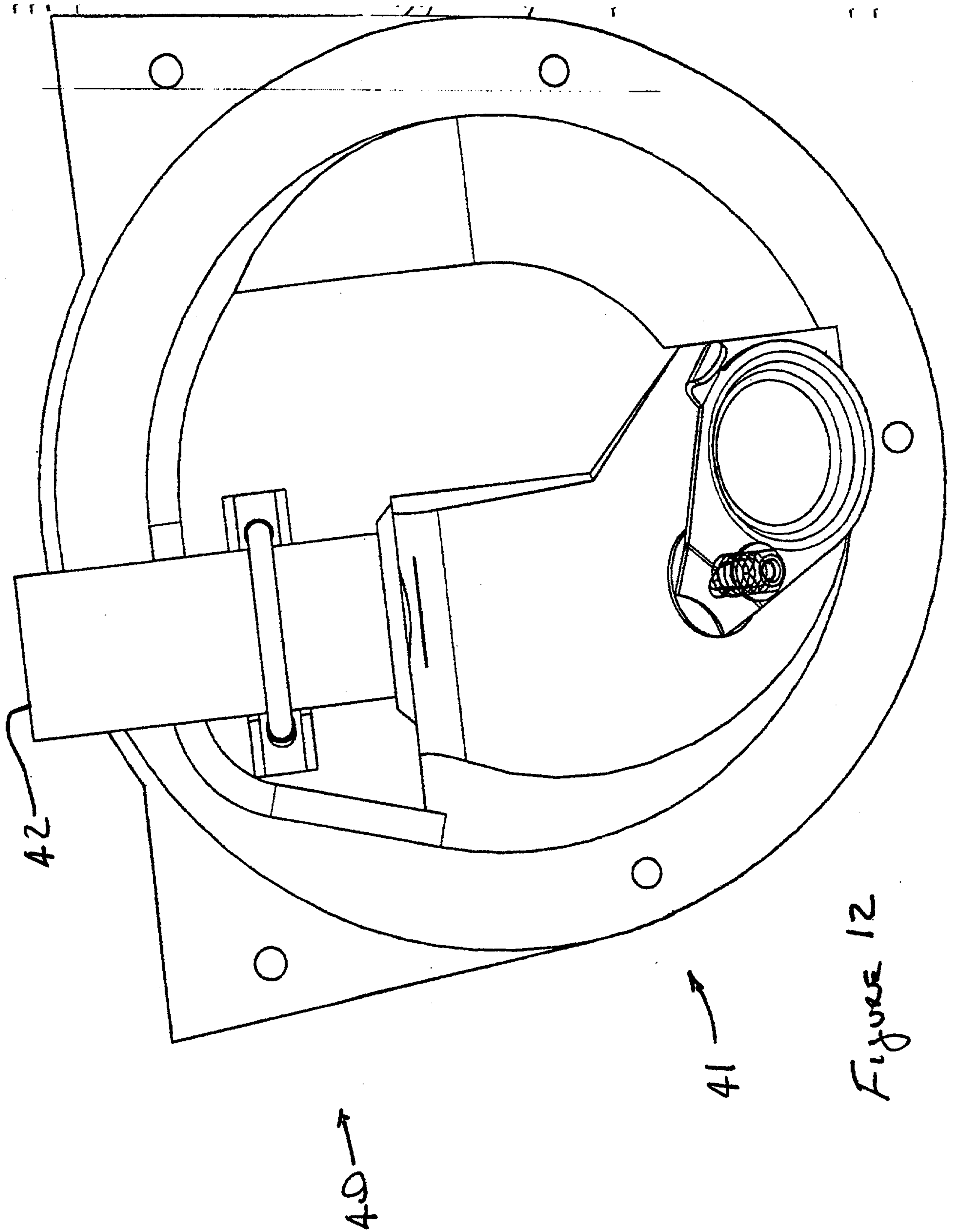

FIGURE 12

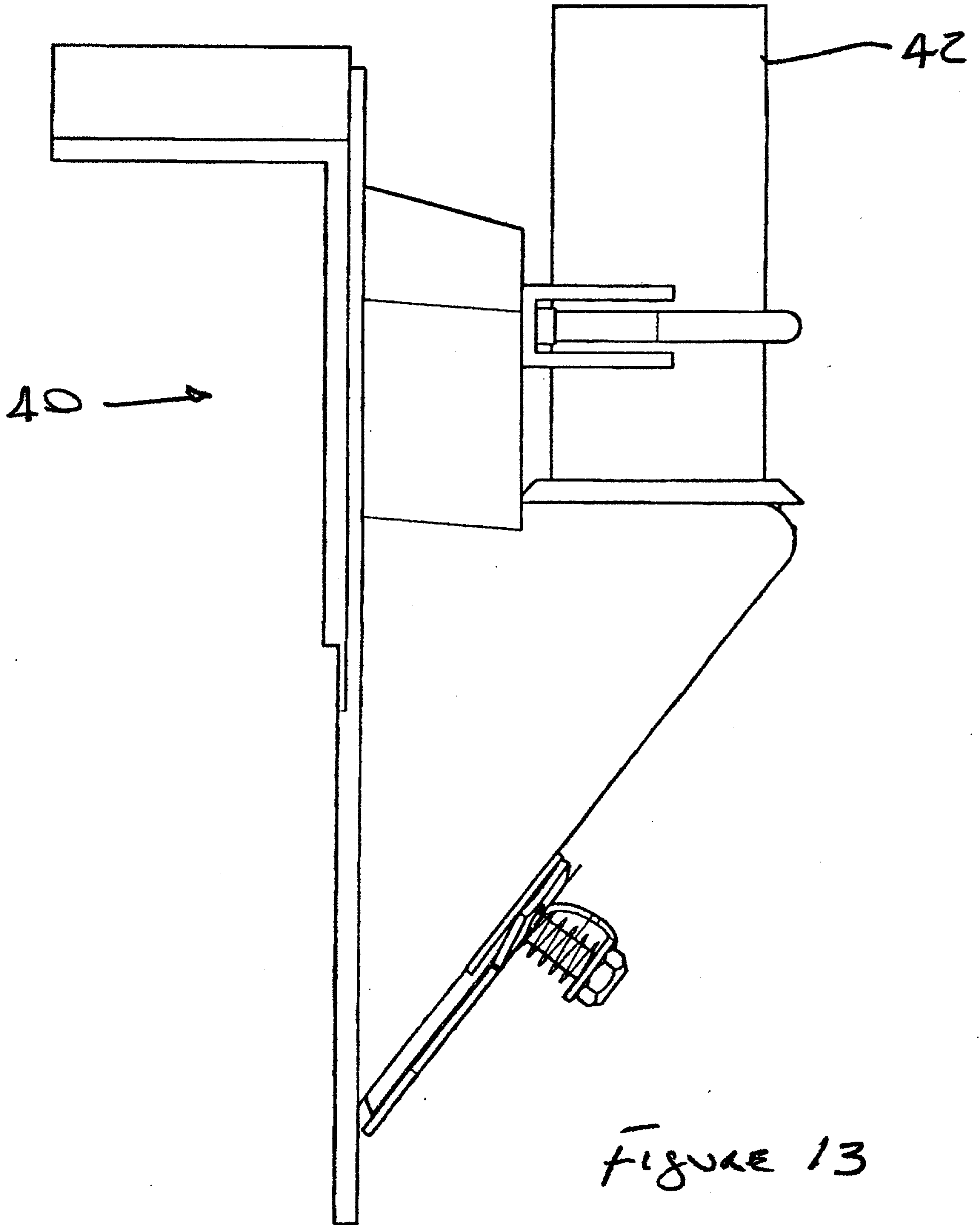

FIGURE 13

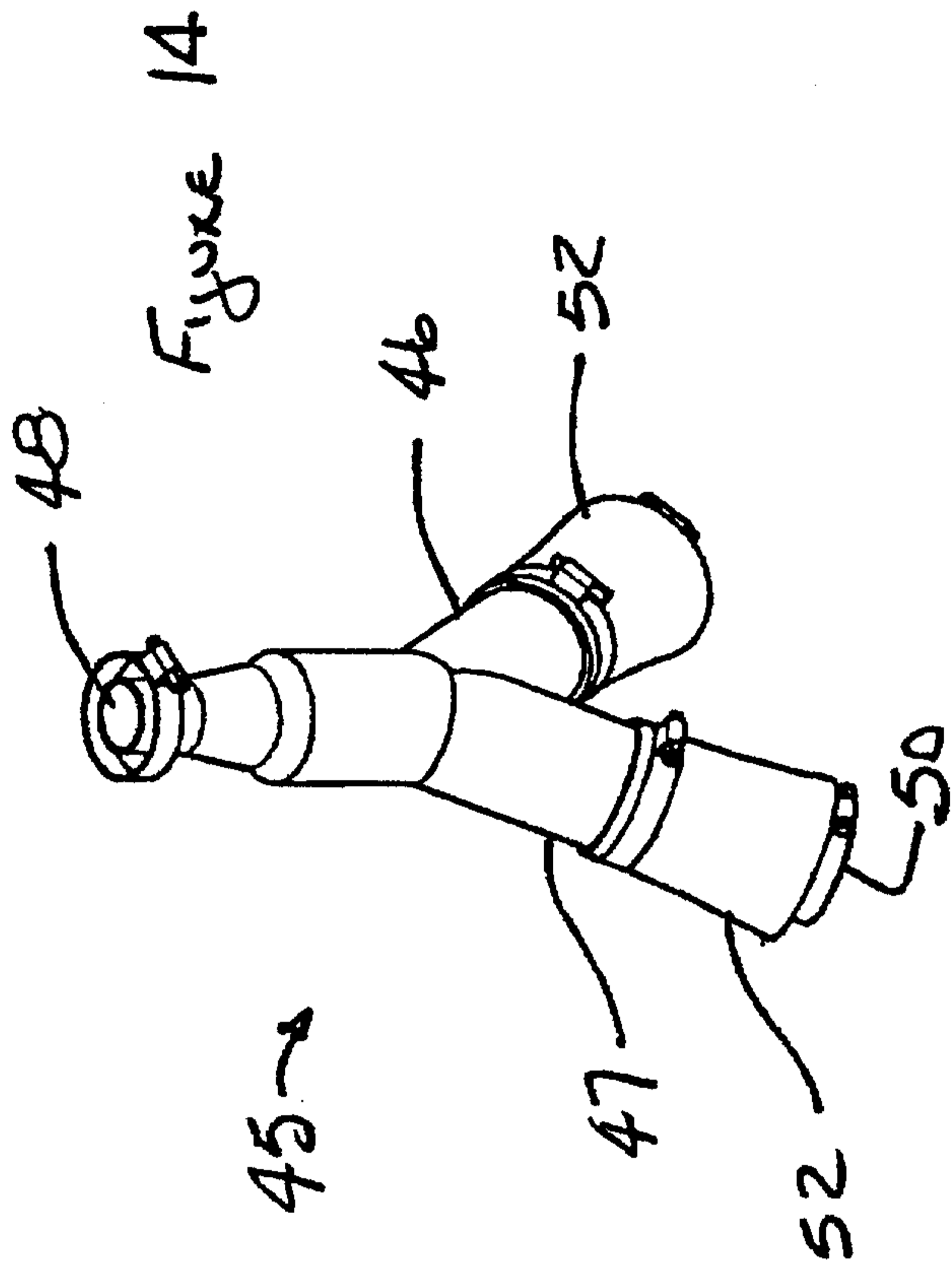

Figure 14

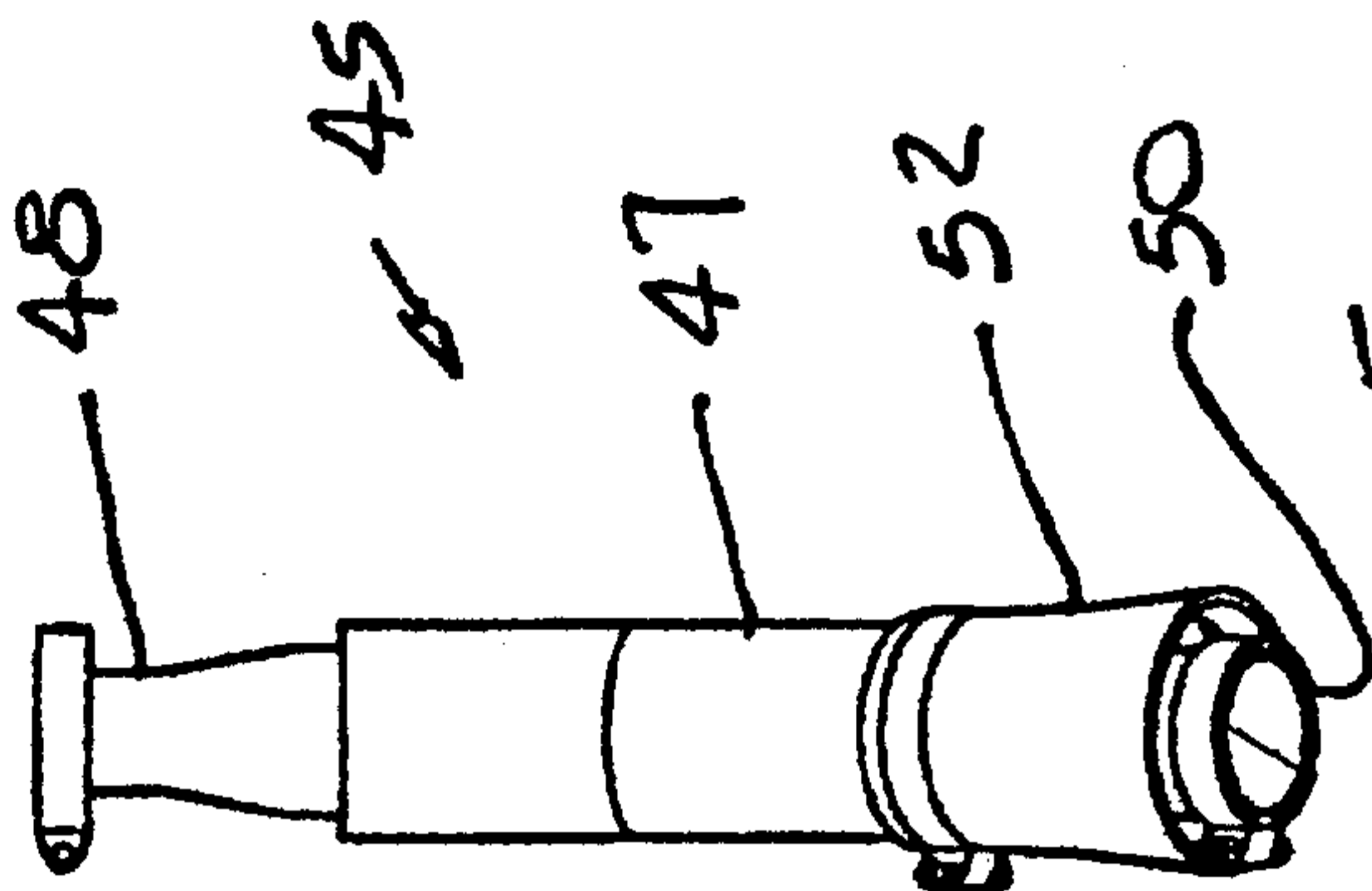

Figure 15

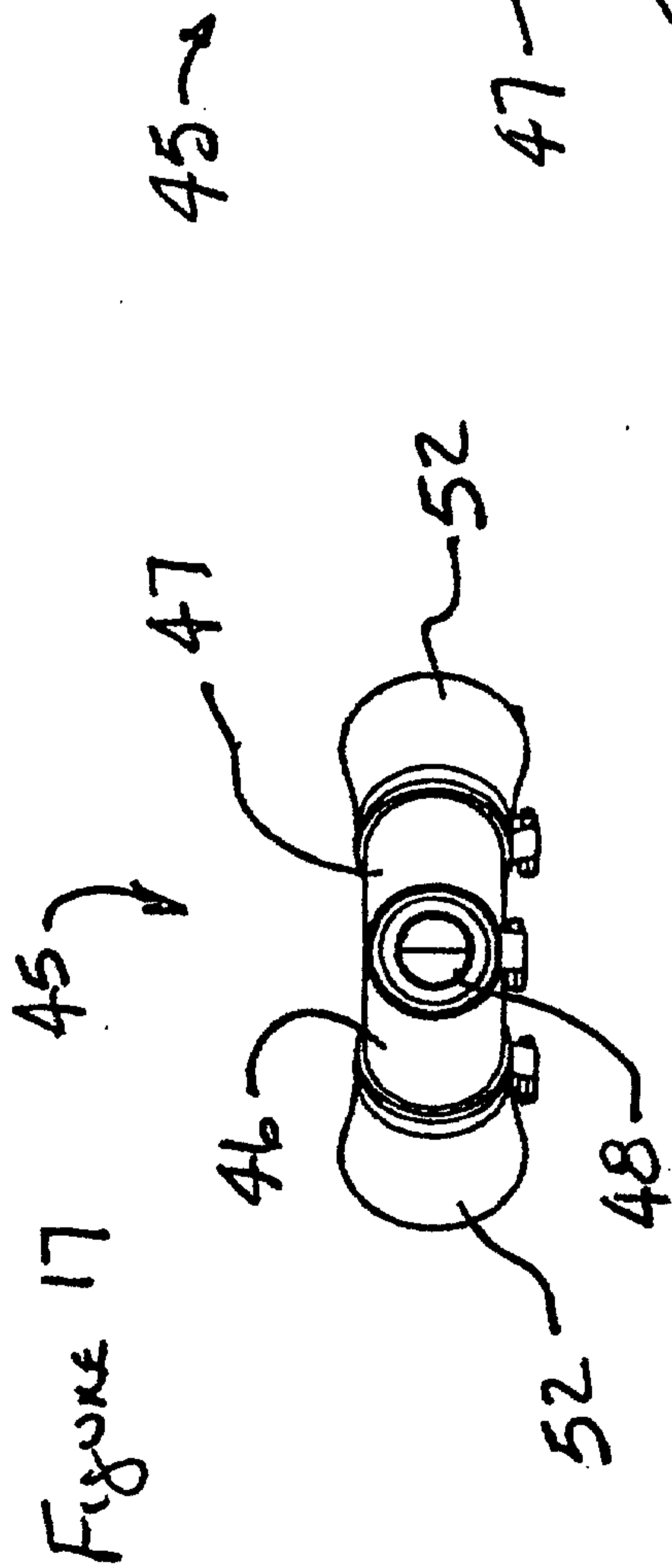

Figure 17

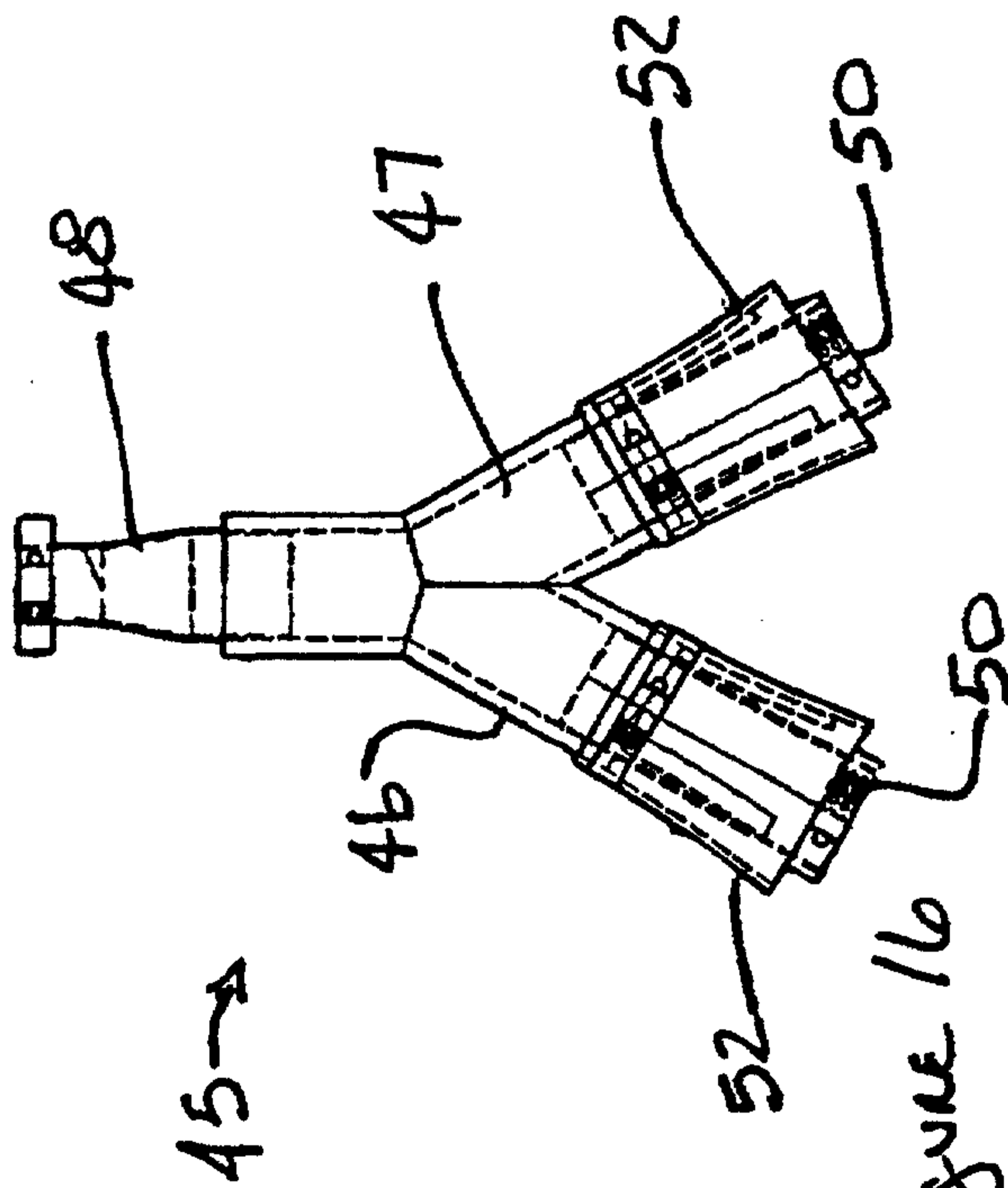

Figure 16

Figure 18A

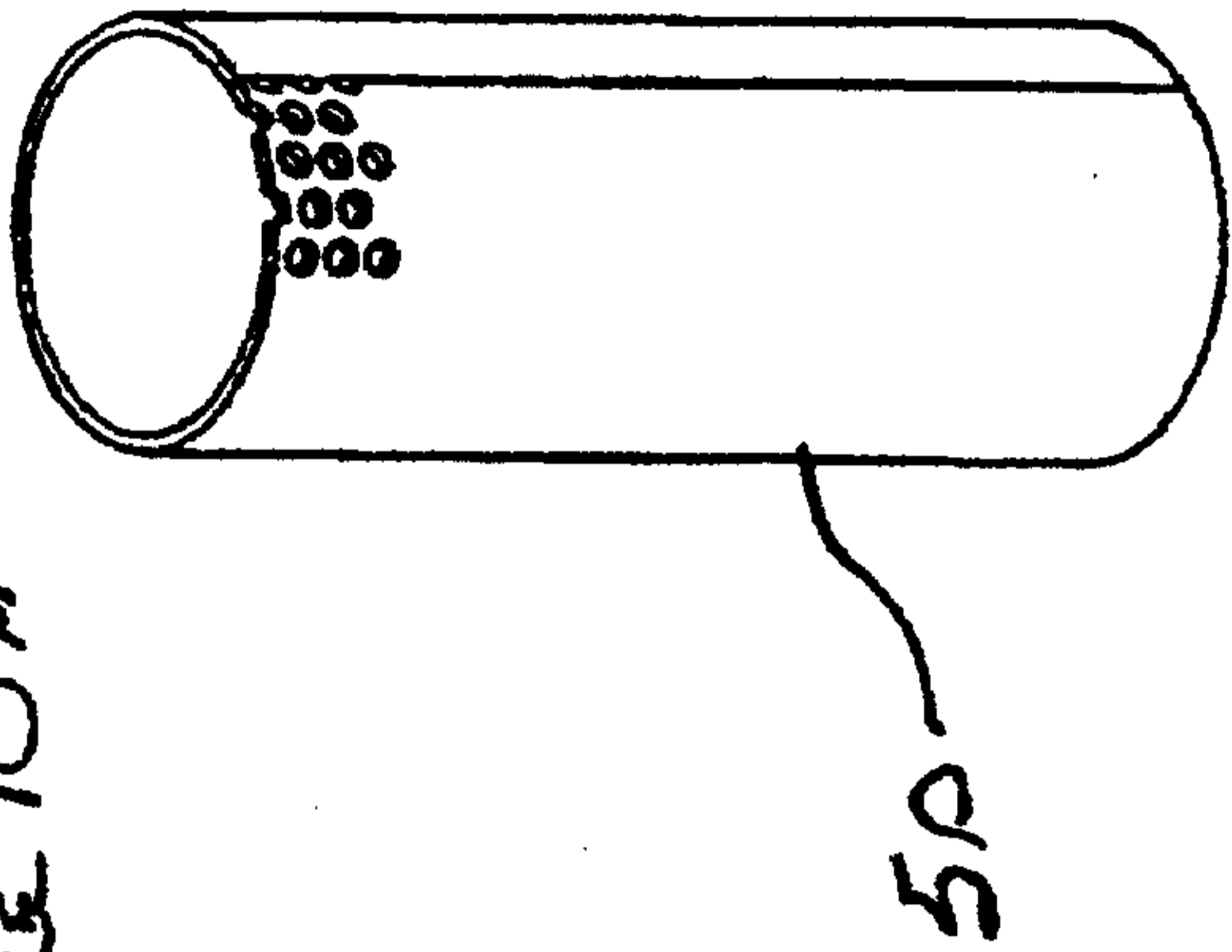

Figure 18d

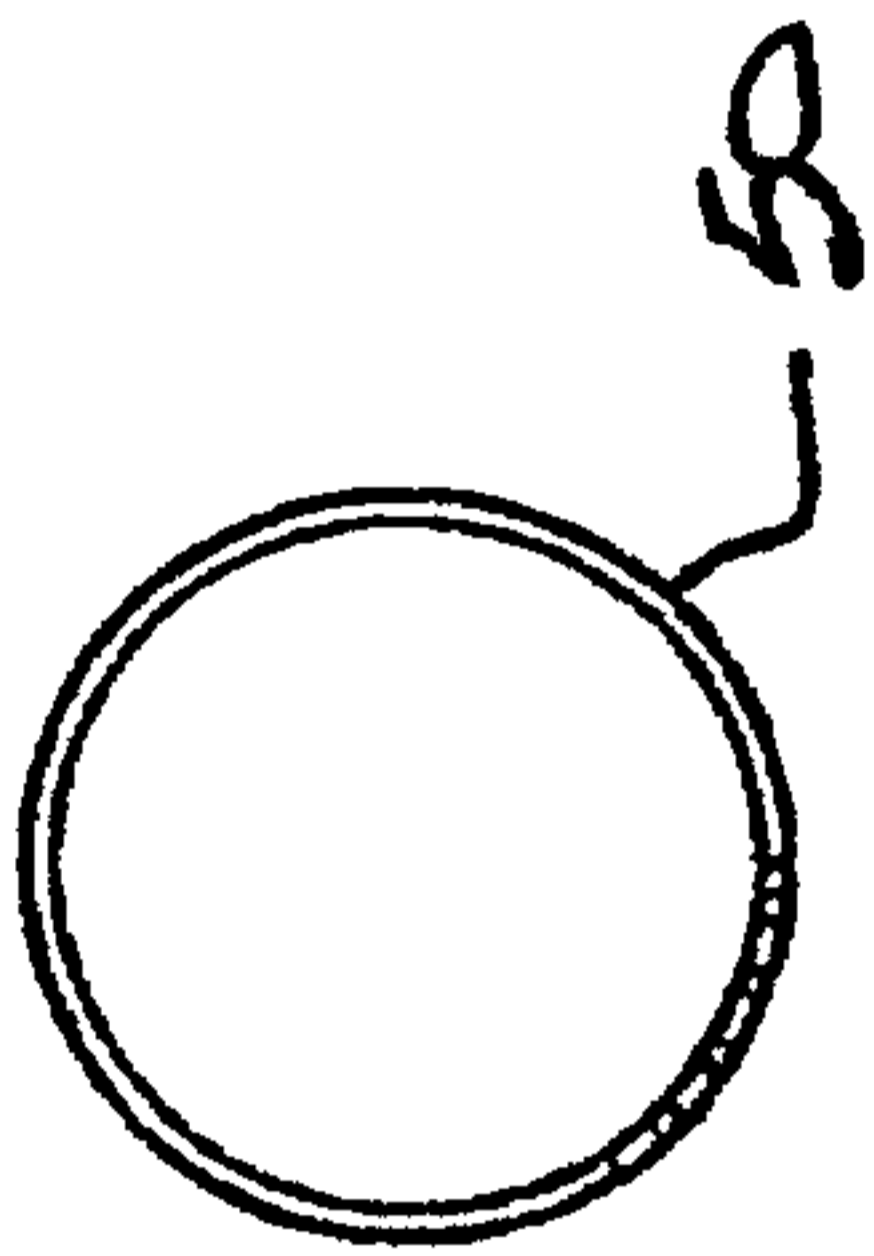

Figure 18c

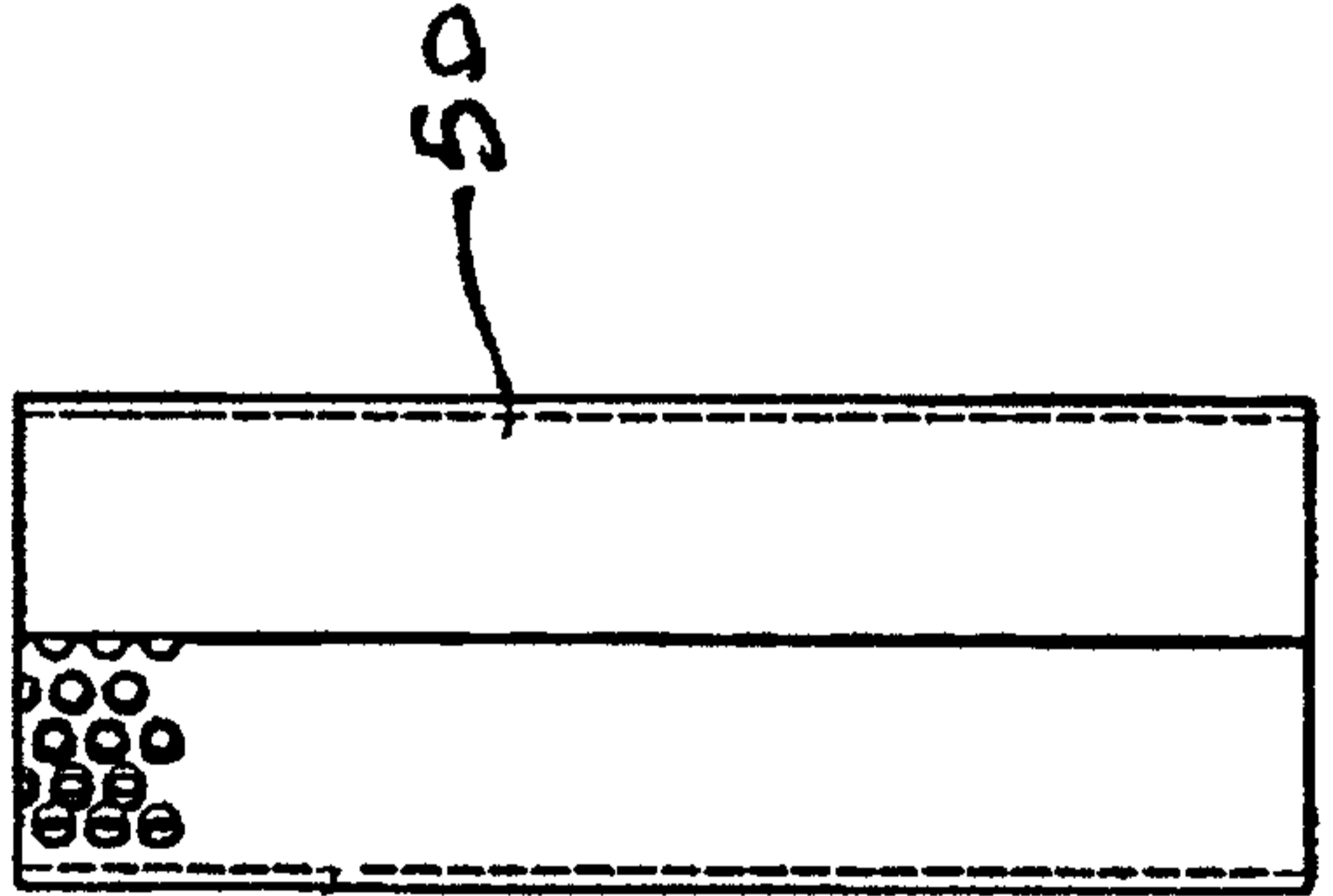

Figure 18b

