



(51) International Patent Classification:

C02F 9/12 (2006.01) C02F 1/78 (2006.01)  
C02F 1/461 (2006.01) E04H 4/16 (2006.01)  
C02F 1/48 (2006.01)

(21) International Application Number:

PCT/CA2012/000555

(22) International Filing Date:

11 June 2012 (11.06.2012)

(25) Filing Language:

English

(26) Publication Language:

English

(30) Priority Data:

61/495,016 9 June 2011 (09.06.2011) US

(72) Inventor; and

(71) Applicant : GEMME, Paul [CA/CA]; 816 Jordi Bonet, Mont Saint-Hilaire, Québec J3H 5M6 (CA).

(74) Agent: EQUINOX; 410 - 1500, Du Collège, Montréal, Québec H4L 5G6 (CA).

(81) Designated States (unless otherwise indicated, for every kind of national protection available): AE, AG, AL, AM, AO, AT, AU, AZ, BA, BB, BG, BH, BR, BW, BY, BZ,

CA, CH, CL, CN, CO, CR, CU, CZ, DE, DK, DM, DO, DZ, EC, EE, EG, ES, FI, GB, GD, GE, GH, GM, GT, HN, HR, HU, ID, IL, IN, IS, JP, KE, KG, KM, KN, KP, KR, KZ, LA, LC, LK, LR, LS, LT, LU, LY, MA, MD, ME, MG, MK, MN, MW, MX, MY, MZ, NA, NG, NI, NO, NZ, OM, PE, PG, PH, PL, PT, QA, RO, RS, RU, RW, SC, SD, SE, SG, SK, SL, SM, ST, SV, SY, TH, TJ, TM, TN, TR, TT, TZ, UA, UG, US, UZ, VC, VN, ZA, ZM, ZW.

(84) Designated States (unless otherwise indicated, for every kind of regional protection available): ARIPO (BW, GH, GM, KE, LR, LS, MW, MZ, NA, RW, SD, SL, SZ, TZ, UG, ZM, ZW), Eurasian (AM, AZ, BY, KG, KZ, RU, TJ, TM), European (AL, AT, BE, BG, CH, CY, CZ, DE, DK, EE, ES, FI, FR, GB, GR, HR, HU, IE, IS, IT, LT, LU, LV, MC, MK, MT, NL, NO, PL, PT, RO, RS, SE, SI, SK, SM, TR), OAPI (BF, BJ, CF, CG, CI, CM, GA, GN, GQ, GW, ML, MR, NE, SN, TD, TG).

Published:

- with international search report (Art. 21(3))
- before the expiration of the time limit for amending the claims and to be republished in the event of receipt of amendments (Rule 48.2(h))

(54) Title: AN ASSEMBLY AND METHOD FOR NON-CHEMICAL TREATMENT OF BATHING WATER

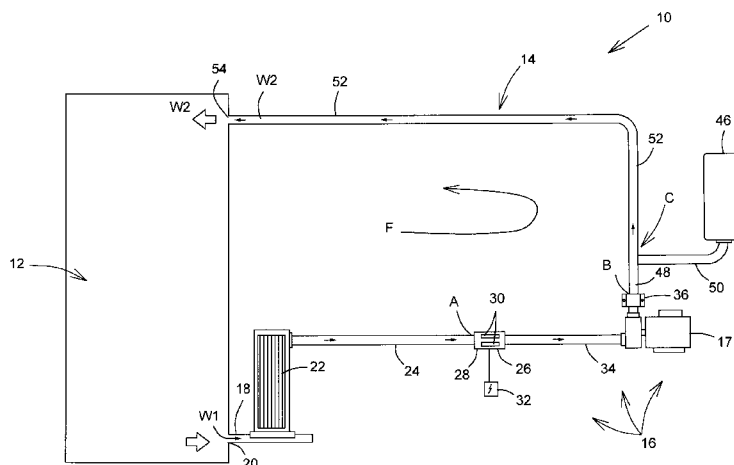

FIG.1

(57) Abstract: A system for treating bathing water comprises a reservoir of untreated water, a conduit circuit in fluid communication therewith and a water treatment assembly mounted to the conduit circuit. The conduit circuit is in fluid communication with the reservoir at a first end thereof for receiving water therefrom via a reservoir outlet and in fluid communication with the reservoir at a second end thereof via reservoir inlet for returning water thereto. The water treatment assembly is mounted to the conduit circuit between the first and second ends thereof. The water treatment assembly comprises a filter for filtering the water, an ion generator for ionizing the water, a magnetizer for creating a magnetic flux within the water, and an ozone generator for injecting ozone into the water. Submitting the untreated water to the water treatment assembly provides for purifying the water.

WO 2012/167363 A1

**TITLE****AN ASSEMBLY AND METHOD FOR NON-CHEMICAL TREATMENT OF  
BATHING WATER****5 CROSS-REFERENCE TO RELATED APPLICATIONS**

**[0001]** The present application claims priority on United States Provisional Application No 61/495,016 filed on June 9, 2011 and incorporated herein in its entirety.

**TECHNICAL FIELD**

10 **[0002]** The present disclosure relates to the treatment of water. More particularly, but not exclusively, the present disclosure relates to systems of purifying waters used in spas, pools, baths or jetted (hot) tubs. Still more particularly, yet still not exclusively, the present disclosure relates to system an assembly and method for non-chemical treatment of bathing water.

**15 BACKGROUND**

**[0001]** Bathing water used in swimming pools, spas, jetted (hot) tubs, public baths and the is treated so as to be purified by a variety of chemicals and bactericides which, in many cases, have an adverse affect on the users of such installations. This is also extremely counter-productive for clients of spas who are  
20 seeking water therapy also known as balneotherapy for various health reasons. Moreover, the various chemicals for treating the water leaves deposits within the water circuit causing damage and requiring replacement of parts.

**[0003]** Therefore, there is both a disadvantage to the chemical treatment of

water with regard to the health of clients as well as to the installations themselves. Heated hot tubs are an ideal location for bacteria to thrive and spread even faster than a swimming pool. In a spa's limited water volume, even a small amount of bacteria can produce a large outbreak. Therefore, it is essential that a spa be kept  
5 free of bacteria and regularly treated and tested.

**[0002]** There thus remains a need for improved water treatment of bathing water in recreational facilities such as spas, hot springs, pools, jetted (hot) tubs, and baths.

### **OBJECTS**

10 **[0003]** It is an object of the present disclosure to provide a system a system for treating bathing water.

**[0004]** It is an object of the present disclosure to provide an assembly for being mounted to a conduit circuit for treating bathing water therein.

15 **[0005]** It is an object of the present disclosure to provide a circuit for treating bathing water and being placed in fluid communication with a reservoir containing the water.

**[0006]** It is an object of the present disclosure to provide a method for treating bathing water of a reservoir for purifying the water.

### **SUMMARY**

20 **[0004]** In accordance with an aspect of the disclosure, there is provided a system for treating bathing water comprising: a reservoir of untreated water; a conduit circuit in fluid communication with the reservoir at a first end thereof for receiving water therefrom via a reservoir outlet and in fluid communication with the reservoir at a second end thereof via reservoir inlet for returning water

thereto; a water treatment assembly mounted to the conduit circuit between the first and second ends thereof, the water treatment assembly comprising: a filter for filtering the water; an ion generator for ionizing the water; a magnetizer for creating a magnetic flux within the water; and - an ozone generator for injecting  
5 ozone into the water, wherein submitting the untreated water to the water treatment assembly provides for purifying the water.

**[0005]** In accordance with an aspect of the present disclosure, there is provided an assembly for being mounted to a conduit circuit for treating bathing water therein, the conduit being in fluid communication with a reservoir at a first  
10 end thereof for receiving untreated water therefrom via a reservoir outlet and in fluid communication with the reservoir at a second end thereof via reservoir inlet for returning water thereto, the assembly comprising: a filter for filtering the water; an ion generator for ionizing the water; a magnetizer for creating a magnetic flux within the water; and an ozone generator for injecting ozone into the water,  
15 wherein submitting the untreated water to the water treatment assembly provides for purifying the water

**[0006]** In accordance with an aspect of the present disclosure, there is provided a circuit for treating bathing water and being placed in fluid communication with a reservoir containing the water for receiving water  
20 therefrom and returning water thereto, the circuit comprising: a filter for filtering the water; an ion generator for ionizing the water; a magnetizer for creating a magnetic flux within the water; and an ozone generator for generating ozone within the water, wherein passage of the untreated water through the circuit provides for purifying the water.

25 **[0007]** In an embodiment, there is provided at least one pump in fluid communication with conduit circuit for circulating water from the reservoir outlet to

the reservoir inlet.

**[0008]** In an embodiment, the filter is mounted within the conduit circuit. In an embodiment, the filter is mounted within the conduit circuit near the reservoir outlet. In an embodiment, the filter is selected from the group consisting of a  
5 cartridge filter, a sand filter, diatomaceous earth filter, a ceramic filters and any combination thereof. In an embodiment, there is provided a plurality of the filters.

**[0009]** In an embodiment, the ion generator comprises a support having a pair of electrodes for being mounted about a portion of the conduit circuit and powered by a power source so as to negatively charge the water molecules  
10 flowing within the portion of the conduit circuit. In an embodiment, there is provided a plurality of the ion generators

**[0010]** In an embodiment, the magnetized comprises a support having magnets for being mounted about a portion of the conduit circuit so as to provide a magnetic flux to the water following within the portion of the conduit circuit. In  
15 an embodiment, there is provided a plurality of the magnetizers.

**[0011]** In an embodiment, the ozone generator is in fluid communication with a portion of the conduit circuit so as to inject ozone therein. In an embodiment, the fluid communication between the ozone generator and the portion of the conduit circuit is provided by an additional conduit. In an  
20 embodiment, the ozone generator is selected from the group consisting of UV ozone generator and Corona Discharge ozone generator. In an embodiment, there is provided a plurality of the ozone generators.

**[0012]** In an embodiment, there is provided a controller in communication

with the water treatment assembly. In an embodiment, there is provided a controller for being in communication with at least one of the filter, the ion generator, the magnetizer, the ozone generator.

**[0013]** In an embodiment, the systems, assemblies, circuits and methods  
5 herein provide for filtering particles from the water, killing micro-organisms within the water, and removing hard water salts, oils and lotions from the water.

**[0014]** In accordance with an aspect of the disclosure, there is provided a method for treating bathing water of a reservoir for purifying the water, the method comprising: (a) circulating the water from the reservoir into a conduit circuit; (b)  
10 filtering the water circulating within the conduit circuit; (c) ionizing the water circulating within the conduit circuit; (d) magnetizing the water circulating within the conduit circuit; and (e) injecting ozone into the water circulating within the conduit circuit; and (f) returning the purified water into the reservoir

**[0015]** In an embodiment, the steps (b), (c), (d) and (e) are performed in  
15 any order but after (a) and before (f). In an embodiment, the steps (b), (c), (d) and (e) are each selectively performed one or more times.

**[0016]** Without limitation to the broad and common definition thereof as would be understood by the skilled artisan within the context of the present disclosure, "bathing water" refers to the water in a variety of recreational  
20 installations used for individual or collective bathing such as spas, hot springs, pools, jetted (hot) tubs, and baths (e.g. Roman or Turkish bathhouses, Japanese Onsens etc.) and the like.

**[0007]** Other objects, advantages and features of the present disclosure will

become more apparent upon reading of the following non-restrictive description of illustrative embodiments thereof, given by way of example only with reference to the accompanying drawings.

### **BRIEF DESCRIPTION OF THE FIGURES**

5    **[0008]**       In the appended drawings:

**[0009]**       Figure 1 is a schematic representation the system for treating bathing water including a conduit circuit for circulating water and an assembly for treating the water in accordance with a non-restrictive illustrative embodiment of the present disclosure;

10   **[0010]**       Figures 2A is a front view of the magnetizer in an open position in accordance with a non-restrictive illustrative embodiment of the present disclosure;

**[0011]**       Figure 2B is a front view of the magnetizer in an open position in positioned about the conduit circuit of the accordance with a non-restrictive illustrative embodiment of the present disclosure  
15

**[0012]**       Figure 2C is a front view of the magnetizer in an open position in mounted on the conduit circuit; and

**[0013]**       Figure 3 of a controller in communication with the assembly for treating water in accordance with a non-restrictive illustrative embodiment of the present disclosure.  
20

### **DETAILED DESCRIPTION**

**[0014]**       Generally stated and in accordance with a non-limiting embodiment, there is provided a system for treating bathing water used in recreational facilities

such as spas, hot springs, pools, jetted (hot) tubs, baths and the like. The system includes a reservoir, a circuit in fluid communication with the reservoir and an assembly of devices mounted to the circuit. The reservoir provides for holding water for bathing purposes and the circuit provides for the untreated or impure  
5 water to flow from the reservoir via a reservoir outlet into the circuit. The water is provided to circulate within the circuit so as to be treated by the assembly of devices and thus purified and to return in a purified form to the reservoir via a reservoir inlet. The assembly of devices provides for purifying the water so as to  
10 kill bacteria, hard water salts, oils, lotions and therefore render used water fit for bathing without the use of chemicals.

**[0015]** With reference to the appended drawings, non-restrictive illustrative embodiments will be described.

**[0016]** Figure 1 shows the system 10 for the treatment of bathing water. The system 10 includes a reservoir or basin 12 of bathing water. The water in  
15 basin 12 is untreated following its use. As such, the water (W1) contains various impurities common to such recreational facilities such as bacteria, oil, lotions, hard water salts and the like. The reservoir 12 is in fluid communication with a water circuit 14 comprising a plurality of conduits or conduit portions. An assembly 16 of devices is mounted to the circuit 14 for treating the water W1 so that it returns as  
20 purified water (W2) back into the reservoir 12.

**[0017]** Water circulates within the circuit 14 by the action of a pump 17 as is well known in the art, in order to flow as shown by the arrow F.

**[0018]** The water W1 from the reservoir 12 flows into a first conduit portion 18 via a reservoir outlet 20. Conduit portion 18 provides for a communication  
25 between the untreated water W1 12 and an initial filter 22 for removing larger particles. Filter 22 can be provided in a variety of different configurations for

providing a fine physical barrier for removing impurities. For example, cartridge filters, sand filters, diatomaceous earth filters, ceramic filters and the like. As is known in the art, filters use a housing with a screen mounted thereto for obstructing particles while allowing water flow to continue. Of course, instead of  
5 using a screen, the filter 22 can use other methods such as adsorption or iron exchange and other like processes in order to remove particles.

**[0019]** Once the water is filtered through filter 22, it is submitted to via conduit portion 24 to an ion generator 26.

**[0020]** The ion generator comprises a strap 28 having a pair of electrodes  
10 30 powered by a power source 32 and being mounted about an area A of the conduit portion 24. The ion generator 26 or negative ion generator is a device that uses high voltage to ionize or electrically charge ambient molecules. More particularly, the ion generator negatively charges the water molecules passing through area A, and in turn, kills the micro-organisms in proximity with these  
15 negatively charged water molecules. As such, the diameter of the conduit portion 24 should be of a convenient size so as to allow the water molecules therein to be sufficiently ionized thereby killing the various micro-organisms (bacteria, algae etc.) therein as a greater surface area is exposed to the action of the ion generator.

20 **[0021]** In one non-limiting example, the ThomsenTec™ ion generator is used.

**[0022]** The water flows from area A into conduit portion 34 to be submitted to the action of a magnetizer 36.

**[0023]** The magnetizer 36 is mounted to area B of the conduit portion 34.  
25 As show in Figure 2A, 2B and 2C, the magnetizer 36 comprises a clamp 37

formed of a pair of concave clamping supports 38a and 38b, with a pair of inwardly inclined magnets 40 each. The clamp 37 is mounted to the conduit portion 34 (at area B) with the magnets 40 abutting the area B in a circumscribing fashion. The flat lateral side extensions 42 of the clamping supports 38a and 38b are fastened together via fasteners 44 such as straps or bolts mounted to ends 42 via apertures (not shown). Thus the magnets 40 surround the conduit portion 34 (at area B) thereby creating a magnetic flux therein

**[0024]** The magnetizer 36 provides for magnetic treatment of the water flowing within area B by providing a magnetic flux therein. More particularly, the magnetizer 36 creates a positive charge in the water dissolving hard water minerals. This removes ugly scale and protects equipment. As water molecules pass through the magnetic field two events occur. Namely, the magnetizer 36 polarizes or organizes molecules and gives water a net positive charge. The magnetizer 36 operates automatically, continuously and permanently using no external power source. Putting a positive charge into the water not only stops scale buildup but also dissolves pre-existing scale deposits. Furthermore, by magnetically organizing the water molecules, the range of the pH is reduced and so is the need for chemical usage.

**[0025]** As such, hard water salts are not only dissolved they are prevented from forming. Hard water is high in mineral content. Even though it is usually not a health hazard it poses a serious problem to the equipment of recreational bathing facility that handles the water. Hence, the magnetizer 36 prevents operational breakdowns that would require maintenance, repair or replacement.

**[0026]**

**[0027]** In one non-limiting example, the magnetizer used is provided by Magnetizer® Industrial Technologies, Inc.

**[0028]** The water flows from area B into conduit portion 46 to be submitted to be submitted to the action of an ozone generator 48.

**[0029]** The ozone generator 48 provides for splitting apart molecules of oxygen into three oxygen atoms by intense UV light thereby or by corona discharge. When a newly freed oxygen atom collides with another oxygen molecule, it joins up forming ozone consisting of three oxygen atoms. Ozone is a strong oxidizer but since it does not last long, it needs to be continuously replenished by the ozone generator 48 to dissolve affected amounts in the treated water within conduit portion 46. Ozone is a much stronger oxidizer of contaminants than regular oxygen because the extra oxygen atom is loosely bound and therefore breaks loose when it comes into contact with organic material such as oils and lotions oxidizing and thereby destroying them in the process. The ozone not only destroys micro-organisms it also breaks down any harmful chemicals that may come into the untreated water and causes total dissolved solids to clump together for easier removal by an additional filter thereby providing cleaner water.

**[0030]** In one example, the ozone generator 46 is an Ultraviolet (UV) ozone generator and includes a lamp that emits UV light (e.g. at 185 nanometers). Air (ambient or otherwise) which splits  $O_2$  molecules in the gas, the resulting oxygen atoms  $O^{\cdot}$  seek stability and attach to other  $O_2$  molecules forming ozone ( $O_3$ ). The ozone is then injected into the water stream where it inactivates contaminates (for example by rupturing their cell wall).

**[0031]** In another example, the ozone generator 46 is a Corona Discharge (CD) ozone generator. This device provides for passing dried (e.g. -80 degrees F), oxygen containing gas through an electrical field which causes the split in the oxygen molecules as explained above. More specifically, an electrical charge is diffused over a dielectric surface creating the electrical field or "corona". Various

frequency ranges can be used (e.g. low frequency: 50-100Hz; medium frequency 100-1000Hz; and high frequency 1000+Hz). Various cooling down methods (e.g. air, water etc.) are used to cool down the generator since it produces large amounts of heat. Once again the ozone is injected into the water.

5 **[0032]** In one non-limiting example, the ozone generator used is provided by UltraPure™ Water Quality Inc.

**[0033]** As such, the ozone generator 46 is in fluid communication with the water within conduit portion 48 via a conduit 50 at area C. Conduit 50 provides for injecting ozone into the water.

10 **[0034]** Thus, the untreated or impure bathing water W1 is filtered, then it is submitted to an ion generator, followed by being submitted to a magnetizer and finally to ozone generator thus purifying the water to produce the treated or pure water W1. Therefore, the method of the present disclosure comprises submitting the water W2 to a filtering process, an ionization process, a magnetizing process  
15 as well as an oxidizing process thereby removing particles, killing micro-organisms, removing hard water salts as well as oil and lotions.

**[0035]** Thus the water W2 returns back to the reservoir via conduit portion 52 through reservoir inlet 54 in a clean state for use without any treatment by organic or chemical compositions.

20 **[0036]** As shown in Figure 3, the system 10 a controller 60, such as a processor in communication (e.g. wireless communication) with a plurality of sensors 62. The sensors 62 can be positioned at various areas within the circuit 14 in order to determine or test the water balance and to evaluate the pH, the copper level within the treated and untreated water and other relevant information.

Furthermore, the devices described above can also be linked to the controller 62 which will evaluate their fixity as is well-known in the art.

**[0037]** The various features described herein can be combined in a variety of ways within the context of the present description so as to provide still other  
5 embodiments. It is to be understood that the present description is not limited in its application to the details of construction and parts illustrated in the accompanying drawings and described hereinabove. The description is capable of other embodiments and of being practiced in various ways. It is also to be understood that the phraseology or terminology used herein is for the purpose of  
10 description and not limitation. Hence, although the present description has been provided hereinabove by way of non-restrictive illustrative embodiments thereof, it can be modified, without departing from the scope, spirit and nature of the disclosure and appended claims.

**WHAT IS CLAIMED IS:**

1. A system for treating bathing water comprising:  
a reservoir of untreated water;  
a conduit circuit in fluid communication with the reservoir at a first  
5 end thereof for receiving water therefrom via a reservoir outlet and in fluid  
communication with the reservoir at a second end thereof via reservoir inlet for  
returning water thereto;  
a water treatment assembly mounted to the conduit circuit between  
the first and second ends thereof, the water treatment assembly comprising:  
10 - a filter for filtering the water;  
- an ion generator for ionizing the water;  
- a magnetizer for creating a magnetic flux within the water; and  
- an ozone generator for injecting ozone into the water,  
wherein submitting the untreated water to the water treatment  
15 assembly provides for purifying the water
2. A system according to claim 1, further comprising at least one  
pump in fluid communication with conduit circuit for circulating water from the  
reservoir outlet to the reservoir inlet.  
20
3. A system according to claim 1, wherein the filter is mounted  
within the conduit circuit.
4. A system according to claim 3, wherein the filter is mounted  
25 within the conduit circuit near the reservoir outlet.
5. A system according to anyone of claims 1, 3 and 4, wherein the  
filter is selected from the group consisting of a cartridge filter, a sand filter,

diatomaceous earth filter, a ceramic filters and any combination thereof.

6. A system according to any one of claims 1 and 3 to 5, wherein the water treatment assembly further comprises a plurality of the filters.

5

7. A system according to claim 1, wherein the ion generator comprises a support having a pair of electrodes for being mounted about a portion of the conduit circuit and powered by a power source so as to negatively charge the water molecules flowing within the portion of the conduit circuit.

10

8. A system according to anyone of claims 1, 6 and 7, wherein the water treatment assembly further comprises a plurality of the ion generators

9. A system according to claim 1, wherein the magnetized  
15 comprises a support having magnets for being mounted about a portion of the conduit circuit so as to provide a magnetic flux to the water following within the portion of the conduit circuit.

10. A system according to anyone of claims 1, 6, 8 and 9, wherein  
20 the water treatment assembly further comprises a plurality of the magnetizers.

11. A system according to claim 1, wherein the ozone generator is  
in fluid communication with a portion of the conduit circuit so as to inject ozone  
therein.

25

12. A system according to claim 11, wherein the fluid communication between the ozone generator and the portion of the conduit circuit is provided by an additional conduit.

13. A system according to any one of claims 1, 11 and 12, wherein the ozone generator is selected from the group consisting of UV ozone generator and Corona Discharge ozone generator.

5                   14. A system according to any on of claims 1, 6, 8, and 10 to13, wherein the water treatment assembly further comprises a plurality of the ozone generators.

10                   15. A system according to any one of claims 1 to 14, further comprising a controller in communication with the water treatment assembly.

15                   16. A system according to any one of claims 1 to 15, wherein the water treatment assembly provides for filtering particles from the water, killing micro-organisms within the water, and removing hard water salts, oils and lotions from the water.

20                   17. An assembly for being mounted to a conduit circuit for treating bathing water therein, the conduit being in fluid communication with a reservoir at a first end thereof for receiving untreated water therefrom via a reservoir outlet and in fluid communication with the reservoir at a second end thereof via reservoir inlet for returning water thereto, the assembly comprising:

25                   - a filter for filtering the water;  
                      - an ion generator for ionizing the water;  
                      - a magnetizer for creating a magnetic flux within the water; and  
                      - an ozone generator for injecting ozone into the water,  
                      wherein submitting the untreated water to the water treatment assembly provides for purifying the water

18. An assembly according to claim 17, further comprising at least

one pump in fluid communication with conduit circuit for circulating water from the reservoir outlet to the reservoir inlet.

19. An assembly according to claim 17, wherein the filter is  
5 mountable within the conduit circuit.

20. An assembly according to claim 19, wherein the filter is mounted  
within the conduit circuit near the reservoir outlet.

10 21. An assembly according to anyone of claims 17, 19 and 20,  
wherein the filter is selected from the group consisting of a cartridge filter, a sand  
filter, diatomaceous earth filter, a ceramic filters and any combination thereof.

15 22. An assembly according to any one of claims 17 and 19 to 21,  
further comprising a plurality of the filters.

23. An assembly according to claim 17, wherein the ion generator  
comprises a support having a pair of electrodes for being mounted about a portion  
of the conduit circuit and powered by a power source so as to negatively charge  
20 the water molecules flowing within the portion of the conduit circuit.

24. An assembly according to anyone of claims 17, 22 and 23,  
further comprising a plurality of the ion generators

25 25. An assembly according to claim 17, wherein the magnetized  
comprises a support having magnets for being mounted about a portion of the  
conduit circuit so as to provide a magnetic flux to the water following within the  
portion of the conduit circuit.

26. An assembly according to anyone of claims 17, 22, 24 and 25, further comprising a plurality of the magnetizers.

27. An assembly according to claim 17, wherein the ozone  
5 generator is in so mountable to the conduit so as to be in fluid communication with a portion thereof so as to inject ozone therein.

28. An assembly according to claim 27, wherein the fluid  
10 communication between the ozone generator and the portion of the conduit circuit is provided by an additional conduit.

29. An assembly according to any one of claims 17, 27 and 28,  
wherein the ozone generator is selected from the group consisting of UV ozone  
15 generator and Corona Discharge ozone generator.

30. An assembly according to any on of claims 17, 22, 24, 27-30,  
further comprising a plurality of the ozone generators.

31. An assembly according to any one of claims 17-30, further  
20 comprising a controller for being in communication with at least one of the filter, the ion generator, the magnetizer, the ozone generator.

32. An assembly according to any one of claims 17-31, wherein the  
25 assembly provides for filtering particles from the water, killing micro-organisms within the water, and removing hard water salts, oils and lotions from the water.

33. A circuit for treating bathing water and being placed in fluid  
communication with a reservoir containing water in communication with for  
receiving water therefrom and returning water thereto, the circuit comprising:

- a filter for filtering the water;
- an ion generator for ionizing the water;
- a magnetizer for creating a magnetic flux within the water; and
- an ozone generator for generating ozone within the water,

5                    wherein passage of the untreated water through the circuit provides  
for purifying the water.

34. A method for treating water of a reservoir for purifying the  
water, the method comprising:

- 10                    (a) circulating the water from the reservoir into a conduit circuit  
                      (b) filtering the water circulating within the conduit circuit;  
                      (d) ionizing the water circulating within the conduit circuit;  
                      (d) magnetizing the water circulating within the conduit circuit; and  
                      (e) injecting ozone into the water circulating within the conduit circuit;
- 15                    and
- (f) returning the purified water into the reservoir

35. The method of claim 34, wherein the steps (b), (c), (d) and  
(e) are performed in any order but after (a) and before (f).

20

36. The method of any one of claims 34 or 35, wherein the steps  
(b), (c), (d) and (e) are each selectively performed one or more times.

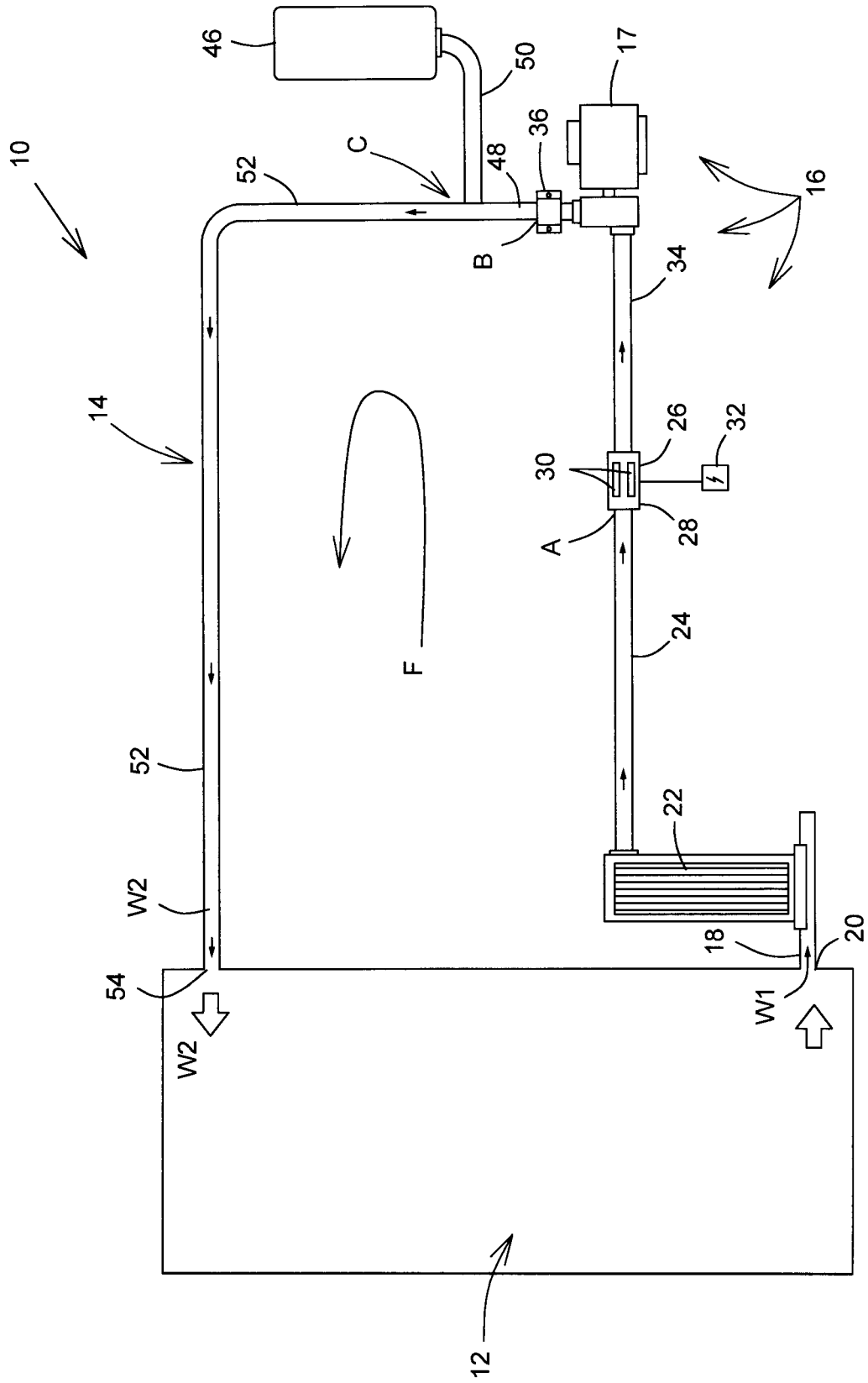
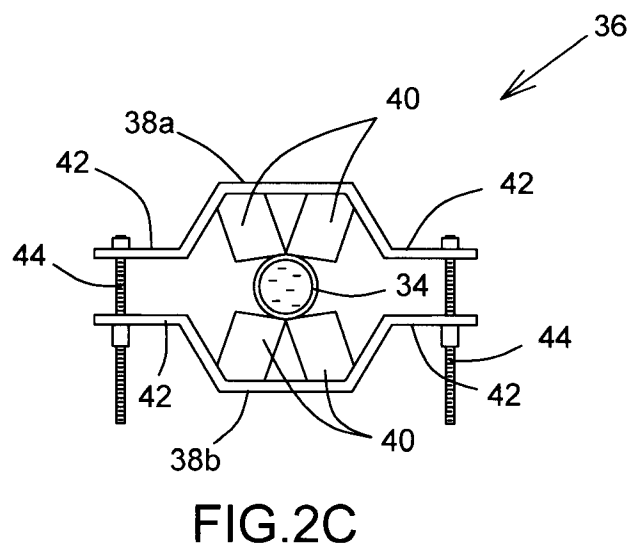
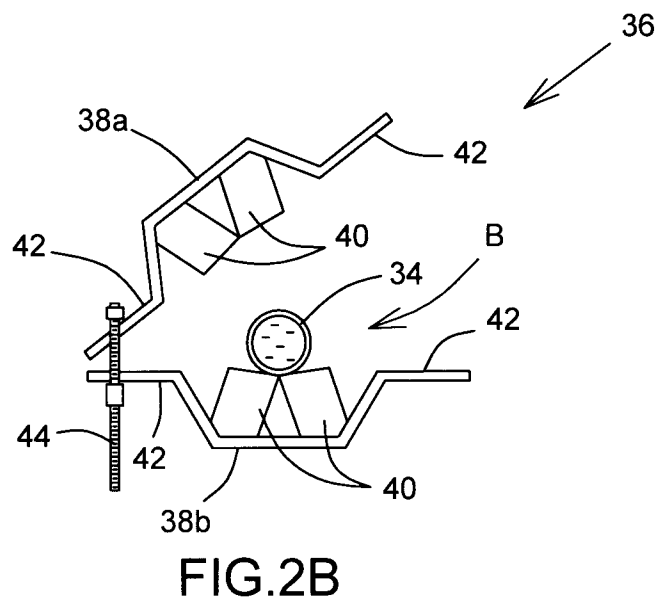
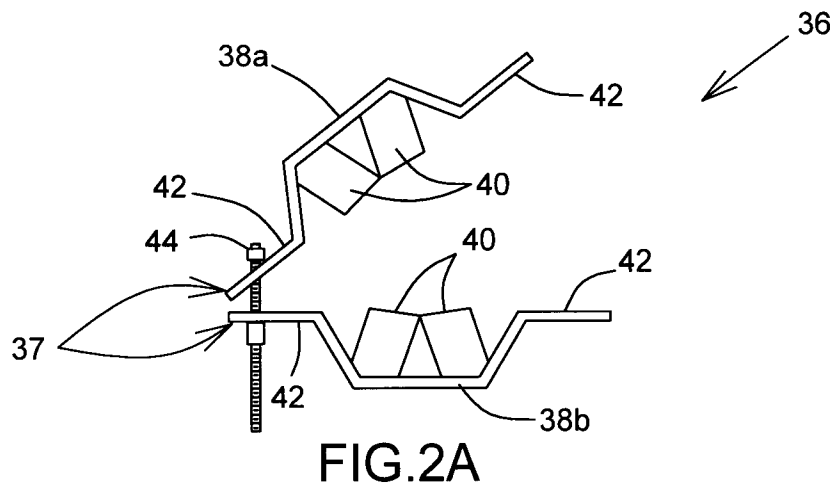

FIG.1



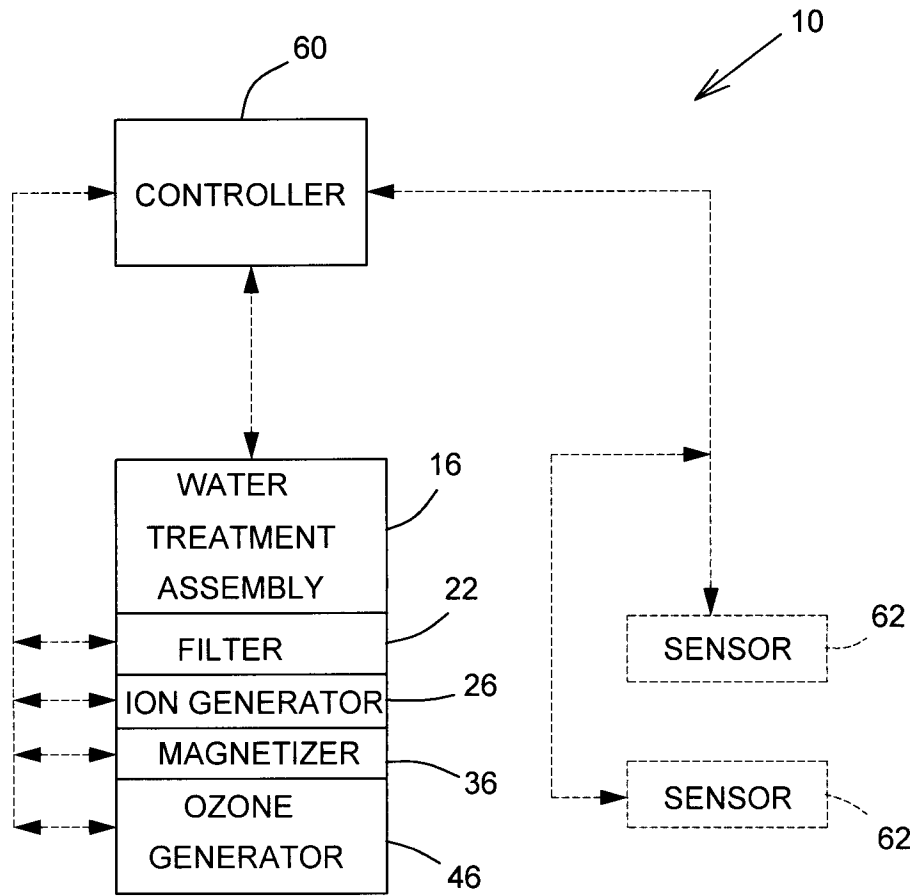

FIG.3

## INTERNATIONAL SEARCH REPORT

International application No.  
PCT/CA2012/000555

| A. CLASSIFICATION OF SUBJECT MATTER<br>IPC: <i>C02F 9/12</i> (2006.01) , <i>C02F 1/461</i> (2006.01) , <i>C02F 1/48</i> (2006.01) , <i>C02F 1/78</i> (2006.01) ,<br><i>E04H 4/16</i> (2006.01)<br>According to International Patent Classification (IPC) or to both national classification and IPC  |   |  |
|--|---|--|
| B. FIELDS SEARCHED   |   |  |
| Minimum documentation searched (classification system followed by classification symbols)<br>IPC: <i>C02F 9/12</i> (2006.01) , <i>C02F 1/461</i> (2006.01) , <i>C02F 1/48</i> (2006.01) , <i>C02F 1/78</i> (2006.01) ,<br><i>E04H 4/16</i> (2006.01)   |   |  |
| Documentation searched other than minimum documentation to the extent that such documents are included in the fields searched<br>N/A   |   |  |
| Electronic database(s) consulted during the international search (name of database(s) and, where practicable, search terms used)<br>Canadian Patent Database, EPOQUE (Epodoc, English FullText); Keywords: filter, filtr+, ion+, magnet+, ozone, o3, electrode, ionifation, magnetifer, ozon+, electrolysis, electrolys+, pool, spa, tub, bath, water, bathing, swim |   |  |
| C. DOCUMENTS CONSIDERED TO BE RELEVANT   |   |  |
| Category*  | Citation of document, with indication, where appropriate, of the relevant passages  | Relevant to claim No.  |
| X  | US 5997812 A (BURNHAM et al.) 07 December 1999 (07-12-1999)<br>**see entire document**  | 1-36   |
| X  | CN 2491449 Y (REN et al.) 15 May 2002 (15-05-2002)<br>**Machine Translation**<br>**Abstract, Fig. 2**                             | 1-36   |
| X  | KR 100311636 B1 (KANG) 27 September 2001 (27-09-2001)<br>**Machine Translation of Abstract**<br>** Abstract, Fig. 1**             | 1-36   |
| X  | CN 2365211 Y (SU et al.) 23 February 2000 (23-02-2000)<br>**Machine Translation**<br>**Abstract, Claims, Last paragraph, Fig. 1** | 1-36   |
| A  | US 7875173 B1 (BARNES) 25 January 2011 (25-01-2011)   | 1-36   |
| <input type="checkbox"/> Further documents are listed in the continuation of Box C. <input checked="" type="checkbox"/> See patent family annex.   |   |  |
| * Special categories of cited documents :  | "T"   | later document published after the international filing date or priority date and not in conflict with the application but cited to understand the principle or theory underlying the invention  |
| "A" document defining the general state of the art which is not considered to be of particular relevance   | "X"   | document of particular relevance; the claimed invention cannot be considered novel or cannot be considered to involve an inventive step when the document is taken alone   |
| "E" earlier application or patent but published on or after the international filing date  | "Y"   | document of particular relevance; the claimed invention cannot be considered to involve an inventive step when the document is combined with one or more other such documents, such combination being obvious to a person skilled in the art |
| "L" document which may throw doubts on priority claim(s) or which is cited to establish the publication date of another citation or other special reason (as specified)  | "&"   | document member of the same patent family  |
| "O" document referring to an oral disclosure, use, exhibition or other means   |   |  |
| "P" document published prior to the international filing date but later than the priority date claimed   |   |  |
| Date of the actual completion of the international search<br>14 August 2012 (14-08-2012)   | Date of mailing of the international search report<br>01 October 2012 (01-10-2012)  |  |
| Name and mailing address of the ISA/CA<br>Canadian Intellectual Property Office<br>Place du Portage I, C114 - 1st Floor, Box PCT<br>50 Victoria Street<br>Gatineau, Quebec K1A 0C9<br>Facsimile No.: 001-819-953-2476  | Authorized officer<br><br>Anne-Marie Garand-Sheridan (819) 934-0665   |  |

**INTERNATIONAL SEARCH REPORT**  
Information on patent family members

International application No.  
**PCT/CA2012/000555**

| Patent Document Cited in Search Report | Publication Date               | Patent Family Member(s)   | Publication Date   |
|--|--------------------------------|---|--|
| US5997812A                             | 07 December 1999 (07-12-1999)  | AU3793697A<br>AU3897897A<br>CA2258865A1<br>US6083387A<br>WO9748421A2<br>WO9748421A3<br>WO9805595A1  | 07 January 1998 (07-01-1998)<br>25 February 1998 (25-02-1998)<br>24 December 1997 (24-12-1997)<br>04 July 2000 (04-07-2000)<br>24 December 1997 (24-12-1997)<br>13 September 2001 (13-09-2001)<br>12 February 1998 (12-02-1998)  |
| CN2491449Y                             | 15 May 2002 (15-05-2002)       | None  |  |
| KR100311636B1                          | 27 September 2001 (27-09-2001) | None  |  |
| CN2365211Y                             | 23 February 2000 (23-02-2000)  | None  |  |
| US7875173B1                            | 25 January 2011 (25-01-2011)   | US6192911B1<br>US2001040122A1<br>US6342154B2<br>US6405387B1<br>US6426053B1<br>US6428756B1<br>US2001042708A1<br>US6623635B2<br>US6723233B1<br>US6881331B1<br>US6893610B1<br>US6951633B1<br>US6967008B1<br>US7060180B1<br>US7135108B1<br>US7186334B1<br>US7329343B1<br>US7604735B1<br>US7658891B1<br>US7883622B1<br>US8048370B1<br>US8061387B1<br>US8075784B1<br>US2002023866A1 | 27 February 2001 (27-02-2001)<br>15 November 2001 (15-11-2001)<br>29 January 2002 (29-01-2002)<br>18 June 2002 (18-06-2002)<br>30 July 2002 (30-07-2002)<br>06 August 2002 (06-08-2002)<br>22 November 2001 (22-11-2001)<br>23 September 2003 (23-09-2003)<br>20 April 2004 (20-04-2004)<br>19 April 2005 (19-04-2005)<br>17 May 2005 (17-05-2005)<br>04 October 2005 (04-10-2005)<br>22 November 2005 (22-11-2005)<br>13 June 2006 (13-06-2006)<br>14 November 2006 (14-11-2006)<br>06 March 2007 (06-03-2007)<br>12 February 2008 (12-02-2008)<br>20 October 2009 (20-10-2009)<br>09 February 2010 (09-02-2010)<br>08 February 2011 (08-02-2011)<br>01 November 2011 (01-11-2011)<br>22 November 2011 (22-11-2011)<br>13 December 2011 (13-12-2011)<br>28 February 2002 (28-02-2002) |