

J. S. DETWILER.

APPARATUS FOR BLENDING POWDERED MATERIALS.

No. 525,095.

Patented Aug. 28, 1894.

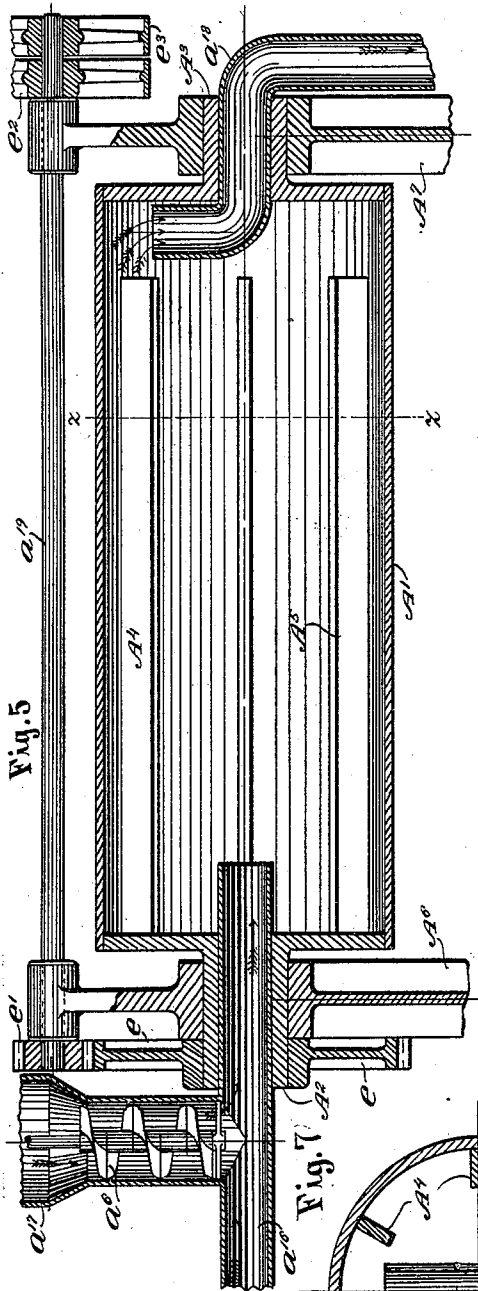

Fig. 5

Fig. 6

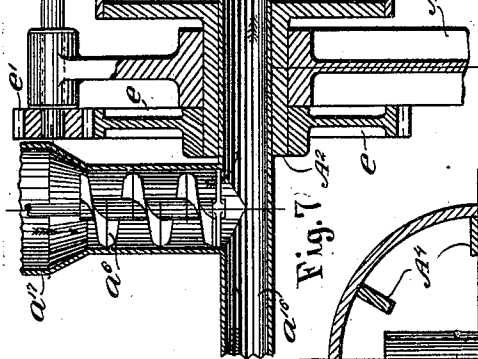
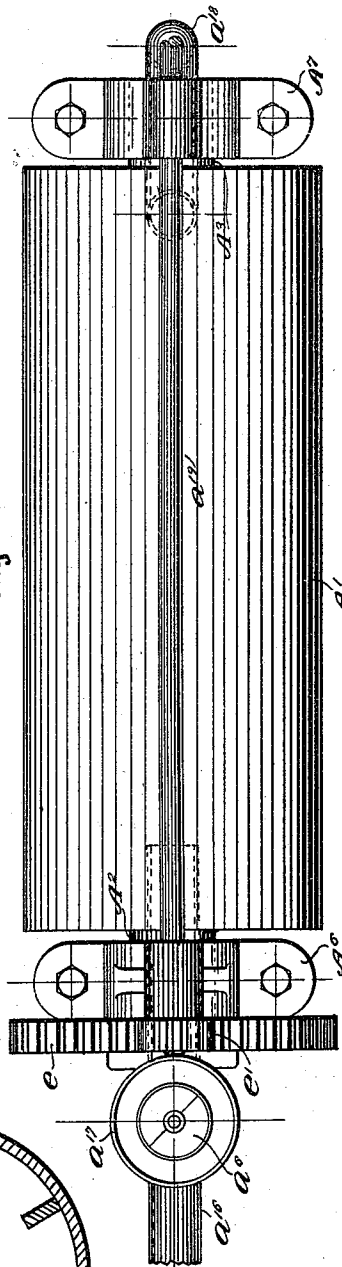

Fig. 7

WITNESSES:
 Thomas M. Smith.
 Richard C. Maxwell.

INVENTOR
John S. Detwiler
 BY
J. Walter Douglas
 ATTORNEY

(No Model.)

4 Sheets—Sheet 4.

J. S. DETWILER.

APPARATUS FOR BLENDING POWDERED MATERIALS.

No. 525,095.

Patented Aug. 28, 1894.

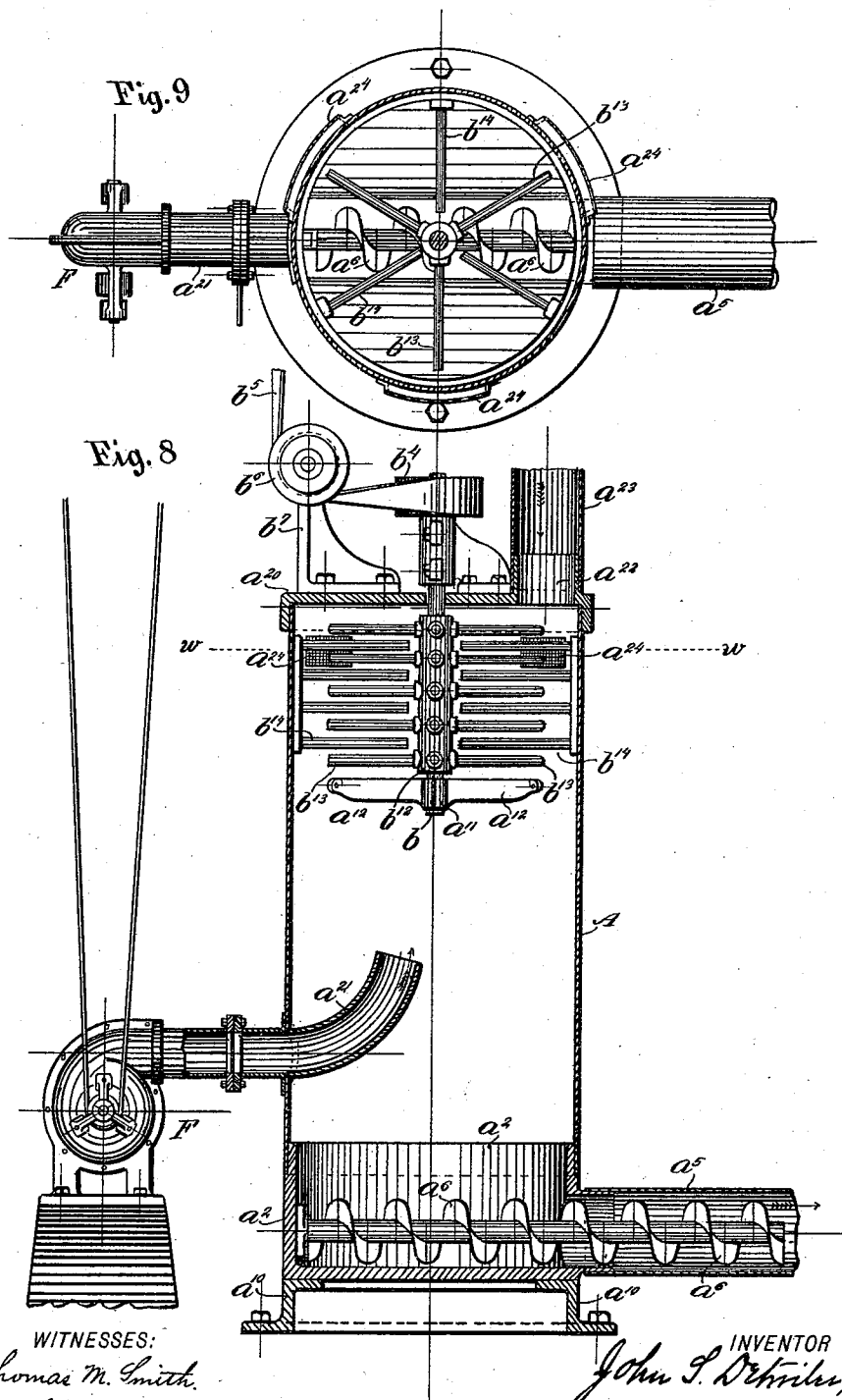

WITNESSES:
Thomas M. Smith.
Richard C. Maxwell.

INVENTOR
John S. Detwiler,
BY
J. Walter Douglas
ATTORNEY.

UNITED STATES PATENT OFFICE.

JOHN S. DETWILER, OF PHILADELPHIA, PENNSYLVANIA, ASSIGNOR TO
WILLIAM P. LOGAN, OF SAME PLACE.

APPARATUS FOR BLENDING POWDERED MATERIALS.

SPECIFICATION forming part of Letters Patent No. 525,095, dated August 28, 1894.

Application filed December 13, 1893. Serial No. 493,540. (No model.)

To all whom it may concern:

Be it known that I, JOHN S. DETWILER, a citizen of the United States, residing at the city of Philadelphia, in the county of Philadelphia and State of Pennsylvania, have invented certain new and useful Improvements in Apparatus for Blending Powdered Materials, of which the following is a specification.

My invention has relation to apparatus for blending or thoroughly commingling powdered or comminuted materials such as different grades or kinds of flour by gaseous or aeriform flotation, agitation, and settling. It is well known that in pulverizing or reducing materials or substances to a comminuted state or condition that a certain amount of heat is generated and in the case of grain or the like, that such heat generated causes the sugar or glutinous constituents of the mass to become adhesive to such an extent as to ball or lump and in such manner as that in the passage of the grain or the like through reducing rolls or millstones for the constituents or particles to become by readhesion combined with or united to one another. Moreover, the heat generated by the milling operation in the case of grain or the like is calculated to produce fermentation, thus causing the product to become sour by exposure and other influences. Again in the practiced methods of treating grain or the like, a large percentage of the moisture taken up by the grain is retained thereby and is calculated to produce fermentation, which results as a consequence in the flour or the like becoming sour and unfit for use.

The principal objects of my invention are first, to overcome entirely the above mentioned disadvantageous features in the treatment of grain or the like and to provide a simple, comparatively inexpensive, expeditious and efficient method for effecting the thorough blending or commingling of such comminuted or powdered material or the like by gaseous or aeriform flotation, agitation and settling; second, to provide an apparatus for thoroughly and expeditiously segregating the particles of the more or less comminuted or pulverized mass, by adhesion clinging to one another, by aeriform or gaseous flotation and mechanical or other agita-

tion to cause the intimate commingling, admixture or thorough blending of the same, freed from heat, moisture and noxious vapors and causing the settling thereof in a perfectly blended, finely divided and purified state or condition in bulk adapted for immediate or subsequent use and entirely free from tendency to fermentation or souring thereof; third, to provide suitable apparatus for producing a perfect blend or admixture of the materials of like or unlike nature, character, specific gravity or kind; and fourth, to provide an apparatus adapted to effect during the operation thereof the purification of the powdered or comminuted materials in such manner as that heat, moisture, gas or other noxious matter is liberated therefrom and with the resultant admixture or perfectly blended product delivered in a chemically pure state or condition for immediate or subsequent use, without manifestation of or tendency to fermentation or souring thereof.

My invention consists of the improvements hereinafter described and claimed.

The nature and general features of my invention will be more fully understood from the following description taken in connection with the accompanying drawings forming part hereof; and in which—

Figure 1, represents a vertical longitudinal section through one form of apparatus adapted for the conduct of the method of my invention, showing a cylindrical shell having a contracted top and outlet, with a series of inlets in the bottom thereof and a screw conveyor for introducing materials in the path of the issuing air, gas or other mixing and purifying agent and with revoluble fans and fingers within said shell for causing in the agitation of the materials lifted into the presence thereof by means of the incoming air, gas or other agent segregation of adhering infinitesimal particles of the mass and the blending of the divided particles of the same, preparatory to the discharge from the apparatus through the outlet in the top thereof. Fig. 2, is a transverse sectional view on the line $x-x$, of Fig. 1. Fig. 3, is a longitudinal section on the line $y-y$, of Fig. 4, of a combined separating and settling chamber provided with a screw conveyor for discharging

the perfectly blended or commingled materials into a suitable receptacle or barrel for use. Fig. 4, is a side elevational view of the separating and settling chamber adapted for use in connection with an apparatus of the type illustrated in Fig. 1, by means of a pipe connection applied to the outlet of the apparatus; the said view illustrating the outlets arranged in the walls of said chamber and covered with wire gauze for permitting of the escape of air therethrough so that effective settling may be insured of the blended materials in the bottom of said chamber and removal thereof be permitted by means of a conveyer adapted to discharge the same through an outlet into a barrel or other suitable receptacle. Fig. 5, is a vertical longitudinal section through a still further modified form of apparatus for blending or commingling different materials and effecting the purification thereof preparatory to settling and the air separated therefrom in a chamber of the general type illustrated in Figs. 3 and 4, and this view showing an air or gas admission pipe in communication with an admission conduit with a rotatable conveyer for admitting materials therethrough, whereby through the intervention of the air, gas or other agent, such materials are presented to the revolving drum provided with stationary beaters or fingers for causing adhering particles to be segregated and the infinitesimal particles of the segregated mass perfectly blended together, preparatory to their discharge from the revolving drum through an outlet conduit connected with one of the journals of said drum and extending into the interior thereof. Fig. 6, is a top or plan view of the apparatus of Fig. 5. Fig. 7, is a transverse section on the line $z-z$, of Fig. 5. Fig. 8, is a vertical longitudinal section of a still further modified form of apparatus adapted for the conduct of my invention, showing a conveyer in the bottom of the chamber, an air or gas admission pipe extending into the same, a shaft provided with revoluble fingers adapted to travel between and about stationary fingers secured to the wall of said chamber and an inlet conduit in the top of said chamber for admitting materials into the interior thereof in a reverse direction to the volume of air, gas or other mixing agent presented thereto, for segregating the particles of the conglomerate and adhering materials and causing the intimate or thorough blending together thereof by the combined action of the air, gas or other agent and the mechanical agitation therein, and showing also means in said chamber for permitting of the liberation of the air, gas or other agent therefrom and settling of the perfectly blended or commingled materials in mass in the bottom of said chamber for permitting of their discharge by means of a conveyer into a suitable receptacle for use; and Fig. 9, is a transverse section on the line $w-w$, of Fig. 8.

In the drawings, with special reference to Figs. 1 and 2, A is a cylindrical shell having

a conical-shaped cap a , provided with a contracted outlet a' .

a^2 , is a cylindrical base engaged by the shell A. In the base a^2 , are provided a series of inlet openings a^3 and an enlarged outlet elbow a^4 , for the reception of a conduit a^5 , which is provided with a screw conveyer a^6 , actuated by any suitable means, not shown. To each of the elbows a^7 of the air or gas inlets a^3 , are secured short sections of pipe a^8 , as clearly shown in Figs. 1 and 2. The base a^2 , is provided with a cone-shaped central bearing post a^9 , which is adapted to be packed with suitable material so as to prevent the settling materials of the chamber from accumulating in the body thereof. The base a^2 , is mounted upon a series of legs a^{10} .

b , is a vertical shaft extending through the cone-shaped bearing post a^9 , and held at the top in a bearing or sleeve a^{11} , provided with radial arms a^{12} , which are respectively secured to the interior wall of the shell A. Between the sleeve or bearing a^{11} , and the shaft b , is interposed an anti-friction bushing a^{13} , to avoid heating up of the shaft and to avoid the necessity of the application of oil or other lubricant thereto. Mounted on the vertical shaft b , at suitable distances apart are radial fingers b^1 , and fans b^2 . The lower end of this shaft is secured in a step bearing a^{14} , mounted on the base-plate a^{15} . The shaft b , is provided with a pulley b^4 , which is keyed or otherwise secured thereto and around which passes a belt b^5 , traveling over pulleys b^6 , which are supported from a standard b^7 , secured to the base-plate a^{15} . Motion is communicated to the belt b^5 , from any suitable source of power, not shown, for rotating the shaft b . Directly above the cone-shaped bearing post a^9 , of the base a^2 , of the shell A, are disposed scrapers b^8 , projecting downwardly and mounted on and rotated by the vertical shaft b . These scrapers are inclined at such an angle as that in the rapid rotation of the shaft b , they will perform the function of lifting the materials carried into the base a^2 , of the shell A, by means of the screw conveyer a^6 .

In use, the machine illustrated in Figs. 1 and 2 operates, as follows: The materials to be segregated and blended enter through the opening a^4 , by means of the screw conveyer a^6 , mounted therein, which uniformly feeds the materials to the base of the shell A, and by means of the current of air, gas or other agent in volume entering through the series of openings a^3 , the materials are lifted aided by the scrapers b^8 , into the presence of the respective revolving fingers and fans, thereby breaking up the particles of the conglomerate mass and thoroughly blending or intermingling the same together and which are supported during the operation by the ascending column or volume of air, gas or other agent and forced thereby through the contracted cap a , of the shell A, and the outlet a' , into a separating and settling chamber D, such as illustrated in Figs. 3 and 4, to be connected

with the outlet a' of the shell A, by a pipe connection with the inlet conduit d , thereof as illustrated in Figs. 3 and 4. The purpose of the separating and settling chamber D, is to receive the intermingled air and thoroughly blended materials free from further agitation and to afford the blended materials, due to their specific gravity, an opportunity to settle in the bottom of the chamber and for any air, gas or other agent carried therewith to pass off through the series of outlets d' , d^2 and d^3 , arranged in the wall of the chamber on opposite surfaces thereof. These outlets are covered with finely meshed wire gauze to prevent passage therethrough with the air or gas of any of the blended materials by suction or otherwise, so that in the falling of the materials in their perfectly blended state or condition into the bottom of the chamber, the mass in bulk is taken by a revoluble screw or endless conveyer d^4 and conducted continuously to the outlet d^5 , in the bottom of the chamber D, and discharged therethrough into a suitable receptacle or barrel d^6 , for use. It may be here remarked that in the operation of the apparatus, the separating and settling chamber D, will always contain a sufficient supply of blended materials to completely cover or envelop the conveyer d^4 , in the bottom thereof, so that the outlet d^5 , at one end of the chamber will always be filled with the blended material, thereby preventing the escape of air through said outlet. This opening as an additional security against the entrance of air through the same may be provided with a wire gauze or other covering extending along far enough to completely cover the outlet d^5 , and thus to form an air trap thereat.

With special reference now to Figs. 5 and 6, showing another form of apparatus for the conduct of my invention of segregating and blending different materials together, A' is a revoluble drum provided with hollow end journals A^2 and A^3 , and with internal beaters or projecting fingers A^4 and A^5 , as illustrated in Fig. 5. These hollow end journals A^2 and A^3 , are mounted in standards A^6 and A^7 extending vertically from a base-plate, not shown. a^{16} , is an air or gas inlet pipe connected with a blast, not shown, and extending through the hollow journal A^2 , of the revoluble drum A' , and in communication therewith is a vertical inlet hopper a^{17} , provided with a screw conveyer a^6 , for the admission and conveyance of materials through the same into the presence of the air or gas adapted to conduct the materials into the interior of the revoluble drum A' . a^{18} , is an outlet pipe extending through the hollow journal A^3 , of the revoluble drum A' and curved upwardly at one extremity thereof and downwardly from the outer end of said journal A^3 , and adapted to be connected with the inlet d , of the separating and settling chamber D, as illustrated in Figs. 3 and 4. On one end of the hollow

journal A^2 , is mounted a gear-wheel e , keyed or otherwise secured thereto and meshing with a pinion e' , mounted on a longitudinal shaft a^{19} , which is journaled to the standards A^6 and A^7 . This shaft a^{19} , is provided on the opposite extremity thereof with loose and fast pulleys e^2 and e^3 , for the reception of a belt, not shown, whereby in the engagement of said belt with the fast pulley on said shaft, motion is imparted to the shaft a^{19} , for actuating the pinion e' , and gear-wheel e , for revolving the drum A' , and thereby causing the materials introduced into the drum to be thoroughly commingled and the infinitesimal particles of said materials to be perfectly blended together, preparatory to their discharge through the curved outlet pipe a^{18} into the separating and settling chamber D, where any air or gas is removed therefrom, through the gauze covered outlets d' , d^2 and d^3 , and the materials thus perfectly blended together, settle in the bottom of the chamber D, and in bulk are removed therefrom by means of the endless conveyer d^4 , as illustrated in Figs. 3 and 4, through the outlet d^5 , into a suitable receptacle or barrel d^6 , for use.

With special reference to Figs. 8 and 9, A represents a cylindrical shell having a shaft b , extending downward through the removable top plate a^{20} thereof. This shaft is provided with a fixed sleeve b^{12} , having radial fingers b^{13} , extending therefrom and adapted to travel between and about the fingers b^{14} , radially disposed and secured to the interior surface of the shell A. F, is an air or gas blowing engine connected with an inlet conduit a^{21} , extending upward into the interior of the shell A. The bottom or base a^2 , is supported on a series of legs a^{10} , and has a large channel or conduit a^3 , with a screw conveyer a^6 , mounted therein for permitting of the discharge of the commingled or perfectly blended materials settling by gravity in the path thereof. In the flanged top a^{20} , of the apparatus is provided a flanged rim or nipple a^{22} , which engages and supports a pipe a^{23} , into and through which the materials to be agitated and blended together are introduced in any suitable manner. In the upper part of the wall of the shell A, are provided a series of radial outlets a^{24} , for permitting the ascending columns of air or gas to escape there-through and at the same time so arranged as to prevent the escape of any of the particles of the materials undergoing agitation and blending together therewith. The shaft b , is provided beyond the top plate a^{20} , of the shell A, with a pulley b^4 , which is engaged by a belt b^5 , passing around a pulley b^6 , which is journaled to a standard b^7 , mounted on the top plate a^{20} , and which belt has motion imparted thereto from any suitable source of power, not shown. The lower end of the shaft b , is supported by a bracket or sleeve a^{11} , provided with radial arms a^{12} , secured to the interior surface of the shell A.

In use, this apparatus of Figs. 8 and 9, is operated as follows:—The materials to be segregated and by agitation, to be perfectly blended together, are introduced through the inlet a^{23} , in the top plate of the shell A, and allowed to descend into the presence of the beaters or fingers b^{13} and b^{14} , for effecting the thorough commingling or admixture thereof and supported during this operation by the ascending column or volume of air or gas continuously presented thereto during agitation and by reason of the greater specific gravity of the materials being blended together than the air or gas holding them for the time being in suspension, such sinks in bulk by gravity therethrough, freeing the air or gas which escapes from the interior of the shell through the radially disposed outlets a^{24} , in the wall thereof, and the blended together material in bulk falls by gravity to the bottom of the apparatus, where by means of the endless screw conveyer a^6 , the same is discharged continuously from the apparatus into any suitable storage receptacle or directly into barrels for shipment or use. It may be here remarked that the materials to undergo the blending operation are fed slowly through the inlet opening in the chamber and fall in the path of the rapidly revolving beaters or fingers and fans and are thoroughly intermingled and blended together by the mechanical action of the same and the air, gas or other agent presented in a reverse direction to the point of admission of the materials into the apparatus, will cause the thorough turning, revolution or whirling around of the various infinitesimal particles of the mass and thus a thorough blending together thereof is insured. By permitting the materials to separate from the air or gas, being lighter than the blended or commingled particles of the mass, the air or gas will rise to the top of the chamber and pass off while the blended together materials in bulk will fall to the bottom of the chamber, and in coming in contact with a conveyer may be conducted off into a suitable receptacle for use. By such mode of operation as hereinbefore described practice has demonstrated that a perfect blend of the different materials will always

be insured at the point of delivery of the same from the apparatus.

Having thus described the nature and objects of my invention, what I claim as new, and desire to secure by Letters Patent, is—

1. An apparatus for blending powdered materials, comprising a chamber having at one portion thereof a force feed, air inlets, and means for producing a current of air for segregating and blending materials together therein, substantially as and for the purposes set forth.

2. An apparatus for blending powdered materials, comprising a drum having at one portion thereof a force feed and a peripheral series of air inlets, and means for producing a current of air for segregating and blending together materials therein, substantially as and for the purposes set forth.

3. An apparatus for blending powdered materials, comprising a drum having at one portion thereof a force feed and a peripheral series of air inlets, a central shaft carrying oblique fan blades for producing a current to the materials and air and beaters for disintegrating and blending together said materials, substantially as and for the purposes set forth.

4. An apparatus for blending powdered materials, comprising a drum provided with a rotatable shaft having fingers and fans connected therewith, means for producing an upward air current in said drum, a conduit for the introduction of materials into said drum in the lower end thereof, a conveyer connected with the bottom of said drum, pipe connections, a separating and settling appliance provided with a rotatable conveyer in the bottom and with a controlled outlet and with screened air and gas outlets in the walls thereof, substantially as and for the purposes set forth.

In testimony whereof I have hereunto set my signature in the presence of two subscribing witnesses.

JNO. S. DETWILER.

Witnesses:

J. WALTER DOUGLASS,
THOMAS M. SMITH.