

(19)



(11)

EP 3 089 190 B1

(12)

EUROPEAN PATENT SPECIFICATION

(45) Date of publication and mention of the grant of the patent:
07.10.2020 Bulletin 2020/41

(51) Int Cl.:
H01H 50/56 (2006.01) H01H 9/38 (2006.01)

(21) Application number: **14841354.5**

(86) International application number:
PCT/JP2014/070777

(22) Date of filing: **06.08.2014**

(87) International publication number:
WO 2015/098171 (02.07.2015 Gazette 2015/26)

(54) **ELECTROMAGNETIC RELAY**

ELEKTROMAGNETISCHES RELAIS

RELAIS ELECTROMAGNETIQUE

(84) Designated Contracting States:
AL AT BE BG CH CY CZ DE DK EE ES FI FR GB GR HR HU IE IS IT LI LT LU LV MC MK MT NL NO PL PT RO RS SE SI SK SM TR

(30) Priority: **27.12.2013 JP 2013272856**

(43) Date of publication of application:
02.11.2016 Bulletin 2016/44

(73) Proprietor: **OMRON Corporation**
Shiokoji-dori, Shimogyo-Ku
Kyoto-shi
Kyoto 600-8530 (JP)

(72) Inventors:
• **HAYASHIDA, Kaori**
Yamaga-shi
Kumamoto 861-0596 (JP)
• **TANAKA, Hiroyasu**
Yamaga-shi
Kumamoto 861-0596 (JP)
• **KOZAI, Yuji**
Yamaga-shi
Kumamoto 861-0596 (JP)

- **NAKAZAKI, Hideo**
Yamaga-shi
Kumamoto 861-0596 (JP)
- **KONDO, Sumihisa**
Yamaga-shi
Kumamoto 861-0596 (JP)
- **SODA, Kazuya**
Yamaga-shi
Kumamoto 861-0596 (JP)
- **TAKAHASHI, Kei**
Yamaga-shi
Kumamoto 861-0596 (JP)

(74) Representative: **Kilian Kilian & Partner**
Aidenbachstraße 54
81379 München (DE)

(56) References cited:
DE-U1- 9 404 775 JP-A- 2002 008 506
JP-A- 2002 008 506 JP-A- 2005 166 431
JP-A- 2005 183 097 JP-A- 2005 183 097
JP-A- 2012 517 092 JP-U- H 027 840
JP-U- H 027 840 US-A1- 2009 033 446

EP 3 089 190 B1

Note: Within nine months of the publication of the mention of the grant of the European patent in the European Patent Bulletin, any person may give notice to the European Patent Office of opposition to that patent, in accordance with the Implementing Regulations. Notice of opposition shall not be deemed to have been filed until the opposition fee has been paid. (Art. 99(1) European Patent Convention).

Description

TECHNICAL FIELD

[0001] The present invention relates to an electromagnetic relay and, more particularly, to an electromagnetic relay having a twin contact structure.

BACKGROUND

[0002] Conventionally, there has been disclosed in, for example, a patent document 1 a twin contact electromagnetic relay. The relay comprises an actuator 22 which is actuated by changing a flow of direction of electric current in the coil assembly 12 to reciprocatingly move a spring assembly 33. The spring assembly 33 comprises a pair of divided springs supporting a pair of contact buttons 37. By the reciprocating movement of the divided springs, the contact buttons 37 make and break contacts with the associated contact buttons 34 mounted on the terminal 31.

[0003] According to the twin contact electromagnetic relay, the contact buttons 37 and 34 have the same configuration and are made from the same material, and the two contact buttons 37 are expected to make simultaneous contacts with the associated contact buttons 34.

Patent Document 1: US Patent No. 7659800

[0004] In fact, however, the contact buttons 37 are unlikely to make simultaneous contacts with the associated contact buttons 34, namely, a contact between one contact button 37 and the associated one contact button 34 occurs earlier than that between the other contact button 37 and the associated the other contact button 34 due to variations in manufacturing and/or assembling thereof, which causes the one contact buttons 37 and 34 to wear more than and, eventually, come to the ends of their lives earlier than the other contact buttons.

[0005] Even if the contact buttons 37 were to make and break contacts with the associated contact buttons 34, they may be damaged by arcing, which results in an unstable contact resistance.

[0006] An electromagnetic relay comprising the features of the preamble of claim 1 is known from US 2009/0033446 A1.

[0007] Further prior art is disclosed in the documents DE 94 04 775 U1, JP 2002 008506 A, JP 2005 183097 A and JP H02 7840 U.

[0008] Considering the above described drawbacks, an object of the invention is to provide a long-life electromagnetic relay capable of flowing electric current under a stable contact resistance.

SUMMARY OF THE INVENTION

[0009] The object is achieved by the features of the independent claim. Further preferred embodiments of the invention are defined by the dependent claims.

[0010] Aspects of the invention are set out below.

[0011] According to an aspect, an electromagnetic relay is provided in which a movable contact plate unit having a plurality of stacked movable contact plates is moved by an actuator plate which moves reciprocatingly by magnetic force generated by an application of electric current to an electromagnetic unit so that a pair of movable contacts mounted on neighborhood, first and second divided plate portions formed by dividing the movable contact plate unit make and break contacts with a pair of stationary contacts mounted on a stationary contact terminal, wherein the relay is configured so that one opening/closing movable contact of the pair of movable contacts makes a contact with one opening/closing stationary contact of the pair of stationary contacts and then the other conducting movable contact of the pair of stationary contacts makes a contact with the other conducting stationary contact.

[0012] According to the aspect, although an arcing may occur between the opening/closing movable and stationary contacts, no arcing occurs between the conducting movable and stationary contacts, reducing contact wearing, which increases contact life and provides a stable operating characteristic for the electromagnetic relay.

[0013] In another aspect, distal ends of the divided contact plates to be moved by the actuator plate are formed with apertures extending around the opening/closing movable contact and the conducting movable contact, and regions of the divided contact plate outside the apertures are bent to form elastically deformable bent portions.

[0014] According to this aspect, the contact pressure can be controlled by adjusting the elastic force from the bent portions.

[0015] In another aspect, a spring constant of the bent portion of the divided plate portion supporting the conducting movable contact is greater than that supporting the opening/closing movable contact.

[0016] According to this aspect, even if the movement of the movable contact plate supporting the conducting movable contact is less than that supporting the opening/closing movable contact, the conducting movable contact eventually establishes the same contact pressure as the opening/closing movable contact.

[0017] In another aspect, a height of the opening/closing stationary contact mounted on the stationary contact terminal is greater than that of the conducting stationary contact mounted on the stationary contact terminal.

[0018] According to this aspect, various advantages that obtained in the previous embodiments are likewise obtained. Also, the height adjustments of the opening/closing and conducting stationary contacts can be made easily, which ensures high precisions in manufacturing and assembling of the components of the electromagnetic relay and provides the electromagnetic relay with no variation in operating characteristic.

[0019] In another aspect, a region supporting the opening/closing stationary contact in the stationary contact terminal is higher than a region supporting the conducting

stationary contact in the stationary contact terminal.

[0020] According to this aspect, various advantages that obtained in the previous embodiments are likewise obtained. Also, a degree of freedom of design can be increased for the electromagnetic relay.

[0021] In another aspect, the conducting movable contact is provided at a distal side of the second divided plate portion and the opening/closing movable contact provided at a proximal side of the first divided plate portion.

[0022] According to this aspect, various advantages that obtained in the previous embodiments are likewise obtained. Also, a larger bending moment acts on the opening/closing movable contact due to the leverage motion derived from the movement of the actuator plate and thereby increases the contact pressure.

[0023] In another aspect, a region for forcing the first divided plate portion supporting the opening/closing movable contact is higher than a region for forcing the second divided plate portion supporting the conducting movable contact.

[0024] According to this aspect, various advantages that obtained in the previous embodiments are likewise obtained. Also, a desired contact pressure and a desired operating characteristic are obtained simply by forming the height difference.

[0025] In another aspect, the first divided plate portion supporting the opening/closing movable contact on the first and second divided plate portions is bent in such a manner such that the opening/closing movable contact approaches the stationary contact than the conducting movable contact on the second divided plate portion.

[0026] According to this aspect, various advantages that obtained in the previous embodiments are likewise obtained. Also, the electromagnetic relay with less variation in operating characteristic and capable of being adjusted simply by being the first and/second divided plate portions is obtained.

BRIEF DESCRIPTION OF THE DRAWINGS

[0027]

Figs. 1A and 1B are a perspective view showing an embodiment of an electromagnetic relay according to the present invention and a perspective view showing a state in which a cover is removed.

Figs. 2A and 2B are plan views showing states brought before/after an operation of the electromagnetic relay illustrated in Fig. 1.

Fig. 3 is an exploded perspective view showing the electromagnetic relay illustrated in Fig. 1A.

Fig. 4 is an exploded perspective view showing the electromagnetic relay illustrated in Fig. 1A as seen at a different angle.

Figs. 5A and 5B are exploded perspective views showing an electromagnetic unit illustrated in Fig. 3.

Figs. 6A and 6B are exploded perspective views showing a movable contact terminal and a movable

contact plate assembly illustrated in Fig. 3.

Fig. 7A is a perspective view showing a first movable contact plate illustrated in Fig. 6, and Fig. 7B is a perspective view for explaining a method of assembling a movable contact terminal and a movable contact plate assembly.

Figs. 8A, 8B, 8C and 8D are sectional views for explaining a step of assembling a movable contact terminal and a movable contact plate assembly.

Fig. 9A is a perspective view showing a variant of the first movable contact plate illustrated in Fig. 6 and Fig. 9B is a perspective view for explaining a method of assembling a movable contact terminal and a movable contact plate.

Figs. 10A, 10B, 10C and 10D are sectional views for explaining an assembling step according to a variant of the movable contact terminal and the movable contact plate assembly.

Fig. 11A is a partial front view showing a contact mechanism and Figs. 11B, 11C, and 11D are sectional views for describing an operating process, taken along B - B lines in Fig. 11A.

Fig. 12A is a partial front view showing a contact mechanism according to a second embodiment of the electromagnetic relay in accordance with the present invention, Fig. 12B is a perspective view showing a stationary contact terminal, and Fig. 12C is a sectional view taken along C - C lines in Fig. 12A.

Fig. 13A is a partial front view showing a contact mechanism according to a third embodiment of the electromagnetic relay in accordance with the present invention, Figs. 13B and 13C are perspective views showing a movable contact terminal, a movable contact piece unit, and a stationary contact terminal, and Fig. 13D is a sectional view taken along D - D lines in Fig. 13A.

Figs. 14A and 14B are a partial front view and a bottom view showing a contact mechanism according to a fourth embodiment of the electromagnetic relay in accordance with the present invention, Fig. 14C is a perspective view showing a card illustrated in Figs. 14A and 14B, and Fig. 14D is a sectional view taken along D - D lines in Fig. 14A.

Figs. 15A and 15B are a partial front view and a bottom view showing a contact mechanism according to a fifth embodiment of the electromagnetic relay in accordance with the present invention, Fig. 15C is a perspective view showing a movable contact piece unit illustrated in Figs. 15A and 15B, and Fig. 15D is a sectional view taken along D - D lines in Fig. 15A.

EMBODIMENTS OF THE INVENTION

[0028] With reference to Figs. 1A-11D, various embodiments of an electromagnetic relay according to the present invention will be described.

[0029] As shown in Figs. 1A to 8D, the electromagnetic relay according to the embodiment of the present inven-

tion generally includes a base 10, an electromagnetic unit 20, a stationary contact terminal 30, a movable contact terminal 40, a movable contact plate assembly 50 securely fixed to the terminal 40, a rotatable actuator 60, an actuator plate 70, a position regulating plate 80, and a cover 90.

[0030] The base 10, which is shaped in the form of rectangular box, has a partition wall 11 protruding from a bottom surface thereof and an engagement recess 11a formed on an upper portion of an inwardly-faced surface of the partition wall 11 as shown in Fig. 3. Also, the base 10 has a pair of terminal slits 12a and 12b formed on peripheral walls partially defining one of internal spaces partitioned by the partition wall 11. A press fitting groove 13 for press fitting one end of the movable contact terminal 40 which will be described below is formed in one of the internal spaces. The base 10 is provided with a positioning projection 14 and a positioning rib 15 (Figs. 2A and 2B) for positioning the electromagnetic unit 20 which will be described below, in the other internal space separated from the one internal space by the partition wall 11. The positioning projection 14 and the positioning rib 15 have positioning holes 14a and 15a provided on upper end surfaces thereof, respectively. In addition, the base 10 has mounting holes 16 provided at diagonally opposing corners thereof and has engaging projections 17 provided on respective outer peripheral surfaces of the base 10.

[0031] As shown in Figs. 5A and 5B, the electromagnetic unit 20 has a spool 21 with flanges 21a and 21b provided on opposite sides thereof, an iron core 23 inserted in a through-hole 21c defined in the spool 21, a coil wound around the spool 21, and substantially L-shaped yokes 24 and 25 fixed to the opposite ends of the iron core 23 protruding from the spool 21. Three coil terminals 26a, 26b, and 26c are press fitted in an edge portion of the flange 21b. As shown in Figs. 2A and 2B, the electromagnetic unit 20 is assembled in the base 10 as it is positioned by the partition wall 11, the positioning projection 14 and the positioning rib 15.

[0032] As shown in Fig. 3, the stationary contact terminal 30 has an opening/closing stationary contact 31 and a conducting stationary contact 32 fixed to one end thereof. The other end thereof is served as a terminal portion 33. The opening/closing stationary contact 31 is made of a metallic material with a high conductivity such as silver. The opening/closing stationary contact 31 and the conducting stationary contact 32 are configured so that a height of opening/closing stationary contact 31 from the stationary contact terminal 30 is greater than that of the conducting stationary contact 32. Also, the opening/closing stationary contact 31 has a greater diameter than the conducting stationary contact 32. A thickness of a silver material covering a surface of the opening/closing stationary contact 31 is greater than that of the conducting stationary contact 32.

[0033] One end of the movable contact plate assembly 50 is fixed to the movable contact terminal 40 through a

fixing projection 41 provided on one end thereof (Fig. 6B). The other end thereof is served as a terminal portion 42.

[0034] As shown in Figs. 6A and 6B, the movable contact plate assembly 50 has stacked, first, second, third and fourth movable contact plates 51, 52, 53 and 54 of which one ends are fixed to the fixing projection 41 of the movable contact terminal 40. In the movable contact plate assembly 50, as shown in Fig. 4, an opening/closing movable contact 57 and a conducting movable contact 58 are fixed to the distal ends of first and second divided plate portions 55 and 56 divided to extend in parallel in its longitudinal direction, respectively, as shown in Fig. 4.

[0035] The opening/closing movable contact 57 is formed by a metallic material with a high conductivity such as silver. The opening/closing movable contact 57 and the conducting movable contact 58 are configured so that a height of opening/closing movable contact 57 from the movable contact plate assembly 50 is greater than that of the conducting movable contact 58. Also, the opening/closing movable contact 57 has a greater diameter than the conducting movable contact 58. A thickness of a silver material covering a surface of the opening/closing movable contact 57 is greater than that of the conducting movable contact 58. Furthermore, the first and second divided plate portions 55 and 56 have fold portions 55a and 56a formed at proximal portions thereof to have a substantially U-shaped configuration. The movable contact plate assembly 50 has a cutout 50a formed at a corner of the proximal end thereof.

[0036] Although the descriptions have been made to the embodiment in which the opening/closing stationary contact 31 and the opening/closing movable contact 57 have greater heights than the conducting stationary contact 32 and the conducting movable contact 58, respectively, the present invention is not restricted to the above embodiment. For example, at least one of the opening/closing stationary contact 31 and the opening/closing movable contact 57 may have a greater height than the conducting stationary contact 32 and the conducting movable contact 58.

[0037] Of course, the movable contact plate assembly 50 may be formed by at least two movable contact plates.

[0038] As shown in Figs. 6A and 6B, the first movable contact plate 51 has two pieces 51a and 51b divided to extend in parallel in its longitudinal direction. The divided plates 51a and 51b have substantially U-shaped fold portions 51c formed at proximal portions thereof. Also, the first movable contact plate 51 has a plurality of fixing holes 51d arranged in parallel on the proximal end and a cutout 51e formed at the proximal end corner thereof. The divided plates 51a and 51b have a semicircular aperture 51f provided adjacent at distal ends thereof and around a portion in which the opening/closing movable contact 57 and the conducting movable contact 58 are provided. A plate portion outside the aperture 51f is bent to form an elastically deformable bent portion 51g.

[0039] According to this embodiment, the substantially

U-shaped aperture 51f is provided to surround the region in which the opening/closing movable contact 57 and the conducting movable contact 58 are disposed, and the plate portion outside of the aperture 51f is bent to form the elastically deformable bent portion 51g. This allows a contact pressure to be controlled by adjusting a shape and size of the aperture 51f and an angle of the bent portion 51g.

[0040] In particular, as shown in Fig. 6B, the bent portion 51g of the divided plate 51b supporting the conducting movable contact 58 in the first movable contact plate 51 is shorter than and has a greater spring constant than that of the divided plate 51a supporting the opening/closing movable contact 57. This ensures that the conducting movable contact 58 and the opening/closing movable contact 57 make substantially the same contact pressure at respective fully closing positions even if the elastic deformation of the divided plate supporting the conducting movable contact 58 after making an electrical contact between the conducting movable and stationary contacts 58 and 32 is smaller than that between the opening/closing movable and stationary contacts 57 and 31.

[0041] As shown in Figs. 6A and 6B, the second movable contact plate 52 has two pieces 52a and 52b divided to extend in parallel in its longitudinal direction. The divided plates 52a and 52b have substantially U-shaped fold portions 52c formed at proximal portions thereof. Also, the second movable contact plate 52 has a plurality of fixing holes 52d arranged in parallel on the proximal end and a cutout 52e formed at the proximal end corner thereof.

[0042] As shown in Figs. 6A and 6B, the third movable contact plate 53 has two pieces 53a and 53b divided to extend in parallel in its longitudinal direction. The divided plates 53a and 53b have substantially U-shaped fold portions 53c formed at proximal portions thereof. Also, the second movable contact plate 53 has a plurality of fixing holes 53d arranged in parallel on the proximal end and a cutout 53e formed at the proximal end corner thereof.

[0043] As shown in Figs. 6A and 6B, the second movable contact plate 54 has two pieces 54a and 54b extending in parallel in its longitudinal direction. The divided plates 54a and 54b have substantially U-shaped fold portions 54c formed at proximal portions thereof. Also, the second movable contact plate 54 has a plurality of fixing holes 54d arranged in parallel on the proximal end and a cutout 54e formed at the proximal end corner thereof. Press-fitting projections 54f are formed by stamping at the proximal end of the plate 54.

[0044] Upper and lower distal end portions of the divided plate 54a are bent in a direction to form a pair of upper and lower positioning tongues 54g and 54g for engagement with an arm 72 of an actuator plate 70 described below.

[0045] Likewise, a distal end of the divided plate 54b is bent in a direction to form a pair of upper and lower positioning tongues 54h for engagement with the arm 72 of the actuator plate 70 described below. One of the po-

sitioning tongue 54h is bent at opposite ends to form positioning ribs 54i for the positioning of the arm 72 in the widthwise direction of the tongue.

[0046] The movable contact terminal 40 with the movable contact plate assembly 50 fixed thereto is press fitted into the press fitting groove 13 of the base 10. In this operation, as shown in Figs. 7A and 7B, the lower end of the movable contact terminal 40 is inserted in the press fitting groove 13 of the base 10 from above. As shown in Figs. 8A and 8B, a thickness W1 of the lower end of the movable contact terminal 40 including the fixing projection 41 is smaller than a width W2 of the press fitting groove 13 ($W1 < W2$), ensuring a smooth assembling without causing any scraping debris. Also, because of the cutout 50a provided at one side corner of the movable contact plate assembly 50, a press fitting can be performed more easily.

[0047] A substantial resistive force is obtained at the insertion of the lower end of the movable contact terminal 40 into the press fitting groove 13 because a thickness W3 of the movable contact terminal 40 including the press fitting projection 54f is greater than or equal to the width W2 of the press fitting groove 13 ($W2 \leq W3$). A further pressing of the movable contact terminal 40 into the groove 13 causes the lower edge of the movable contact terminal to be forcedly engaged with the stepped portion 13a formed on the inside surface of the press fitting groove 13 and thereby held immovably. The scraping debris generated at the press fitting maybe accommodated within a collecting recess 13b formed on a bottom surface of the press fitting groove 13, which is sealingly covered with the movable contact terminal 40.

[0048] Although the descriptions have been made to the embodiment in which the two press fitting projections 54f are formed on the fourth movable contact plate 54 of the movable contact plate assembly 50, the present invention is not limited thereto. For example, at least one press fitting projection 54f may be sufficient. Alternatively, as shown in Figs. 9A and 9B and Figs. 10A to 10D, two press fitting projections 54f may be provided on upper and lower ends of the fourth movable contact plate 54, namely, four fitting projections may be provided in total.

[0049] Because other structures are substantially the same as the corresponding structures of the first embodiment, like parts are designated by like reference numerals and duplicate descriptions are eliminated.

[0050] As shown in Figs. 3 and 4, the rotatable actuator 60 has first and second movable iron plates 61 and 62 integrally assembled therewith and holding a permanent magnet therebetween. The actuator 60 further has rotating shafts 63 and 64 protruding coaxially from the upper and lower surfaces and an operation arm 65 protruding from a side surface thereof.

[0051] The actuator 60 is mounted in the base 10 with the rotating shaft 63 inserted in the bearing recess (not shown) formed in the bottom surface of the base 10 so that one ends of the first and second movable iron plates 61 and 62 move to the magnetic poles 24a and 25a and

the other ends of the first and second movable iron plates 61 and 62 move away from the magnetic poles 24a and 25a, and vice versa, alternately.

[0052] As shown in Figs. 3 and 4, the actuator plate 70 has an engaging hole 71 formed on one end thereof. The rectangular engaging hole 71 is configured to engage with the operation arm 65 of the rotatable actuator 60. The actuator plate 70 further has an upwardly extending engaging arm 72 integrally formed therewith on the other end thereof to define an engaging slot 73 therebetween. The engaging arm 72 has two positioning projections 74 formed at lower side thereof.

[0053] The operation arm 65 of the rotatable actuator 60 is engaged in the engaging hole 71 of the actuator plate 70. The distal end of the movable contact plate assembly 50 is engaged in the engaging slot 73. The engaging arm 72 is engaged with the positioning tongues 54g of the divided plate 54a of the fourth movable contact plate 54 and the positioning tongues 54h and 54i of the divided plate 54b.

[0054] Further, the position regulating rib 54i of the positioning tongue 54h are positioned between the pair of position regulating projections 74 of the engaging arm 72, preventing a displacement of the movable contact plate assembly 50 in a vertical or widthwise direction thereof, which ensures a reliable operating characteristic of the electromagnetic relay.

[0055] As shown in Figs. 3 and 4, the position regulating plate 80 has a planar configuration to extend between the positioning projection 14 and the positioning rib 15. The plate 80 has positioning projections 81 and 82 provided at opposite ends of its lower surface, which are configured so that they can fit in the positioning holes 14a and 15a of the positioning projection 14 and the positioning rib 15, respectively. The plate 80 further has a through hole 83 provided on a central portion thereof so that the rotation shaft 64 of the rotatable actuator 60 can be engaged in the hole.

[0056] As shown in Figs. 3 and 4, a cover 90 takes a planar configuration such that it covers the opening of the base 10 and has at respective diagonally opposing corners thereof cylindrical connecting portions 91 formed with through-holes 91a. The cover 90 has elastic engaging portions 92s formed in respective positions of the outer peripheral edges, corresponding to the engaging projections 17 of the base 10. The cover 90 has a projection 93 formed on a ceiling thereof which engages with the corresponding engagement recess 11a of the partition wall 11 of the base 10.

[0057] The cover 90 is mounted from above on the base 10 supporting the above described components already mounted thereon. The cylinder portions 91 of the cover 90 are engaged in the holes 16 on the base 10, and the elastic engaging portions 92 of the cover 90 are engaged with the engaging projection 17 of the base 10, which completes the assembling of the base and the cover.

[0058] According to the embodiment, the larger diam-

eter opening/closing movable contact 57 is disposed adjacent the opening of the base 10, which advantageously ensures a reliable inspection and adjustment at the assembling and an enhanced productivity of the relay.

[0059] Next, an operation of the electromagnetic relay according to the present embodiment will be described.

[0060] As shown in Fig. 2A, one end 61a of the first movable iron plate 61 and the other end 62b of the second movable iron plate 62 are magnetically attracted to the magnetic poles 24a and 25a of the yokes 24 and 25 by a magnetic force of the permanent magnet, respectively, as shown in Fig. 2A. In this condition, the actuator plate 70 engages the operation arm 65 of the rotatable actuator 60 and takes a return position so that the opening/closing movable contact 57 and the conducting movable contacts 58 are disconnected from the opening/closing and conducting stationary contacts 31 and 32. An opposing distance between the opening/closing stationary contact 31 and the opening/closing movable contact 57 is smaller than that between the conducting stationary contact 32 and the conducting movable contact 58 (Fig. 11A).

[0061] When a voltage is applied to the coil 22 in a manner such that it energizes to cancel the magnetic force of the permanent magnet, the rotatable actuator 60 rotates against the magnetic force of the permanent magnet, causing that one end 61a of the first movable iron plate 61 and the other end 62b of the second movable iron plate 62 are disconnected from the magnetic poles 24a and 25a of the yokes 24 and 25 and the other end 61b of the first movable iron plate 61 and one end 62a of the second movable iron plate 62 attract the magnetic poles 25a and 24a of the yokes 25 and 24, respectively. As a result, the operation arm 65 of the rotated rotatable actuator 60 slidingly moves the actuator plate 70 so that the inside surface of the engaging slot 73 of the actuator plate 70 simultaneously forces the bent portions 51g of the first movable contact plate 51. This in turn causes that the opening/closing movable contact 57 and the conducting movable contact 58 move around fixing projections 41 where the movable contact plates are fixed to the movable contact terminal 40. This results in that the opening/closing movable contact 57 makes a contact with the opening/closing stationary contact 31 (Fig. 11C) and then the conducting movable contact 58 comes in contact with the conducting stationary contact 32 (Fig. 11D). Further, the actuator plate 70 forces the bent portions 51g of the movable contact plate assembly 50. It should be noted that, the bent portion 51g of the divided plate 51b with the conducting movable contact 58 is shorter than and has a greater spring constant than the bent portion 51g of the divided plate 51a. This ensures that, even a small amount of movement of the conducting movable contact 58 relative to the opening/closing movable contact 57 eventually allows the opening/closing movable contact 57 and the conducting movable contact 58 to contact the opening/closing stationary contact 31 and the conducting stationary contact 32 with a uniform contact pressure, respectively.

[0062] The application of the voltage to the coil 22 is halted subsequently, in which the rotatable actuator 60 is held in the same position by the magnetic force of the permanent magnet (Fig. 3).

[0063] Subsequently, when a voltage is applied to the coil 22 in a manner such that it energizes to cancel the magnetic force of the permanent magnet, the rotatable actuator 60 rotates in the opposite direction, causing the operation arm 65 to move the actuator plate 70 and also the engaging arm 72 of the actuator plate 70 to move the distal end of the movable contact plate assembly 50 back into their original positions, respectively (see Fig. 2).

[0064] According to the present embodiment, the relay is unlikely to be damaged by arcing which may occur between the opening/closing movable contact 57 and the opening/closing stationary contact 31. Also, the arcing is less-likely to occur between the conducting movable contact 58 and the conducting stationary contact 32. Advantageously, this prevents shortening of the contact life which would otherwise be caused by the contact wear and ensures a reliable conducting characteristic in the relay.

[0065] The electromagnetic relay according to the second embodiment is substantially the same as the first embodiment, as shown in Figs. 12A to 12C, except that the stationary contact terminal 30 has stepped convex and concave surface portions 34 and 35, by stamping the terminal 30 on which the opening/closing and conducting stationary contacts 31 and 32 are securely fixed.

[0066] Accordingly, this arrangement provides not only various advantages similar to the first embodiment of the invention but also another advantage, for example, in increasing the possibility of design of the relay.

[0067] Because other structures are substantially the same as the corresponding structures of the first embodiment, like parts are designated by like reference numerals and duplicate descriptions are eliminated.

[0068] The electromagnetic relay according to the third embodiment is substantially the same as the first embodiment, as shown in Fig. 13A to 13D, except that in the fourth opening/closing movable contact 57 the conducting movable contact 58 of the second divided plate portion 56 is positioned distally than the opening/closing movable contact 57 of the first divided plate portion 55.

[0069] More specifically, in the movable contact plate assembly the opening/closing movable contact 57 is mounted on the proximal side of the first divided plate portion 55 while the conducting movable contact 58 is mounted on the distal side of the second divided plate portion 56. Correspondingly, the opening/closing and conducting stationary contacts 31 and 32 are fixed to portions opposing the opening/closing and conducting movable contacts 57 and 58, respectively.

[0070] According to this embodiment, the first and second divided plate portions 55 and 56 move toward the stationary contact terminal 30 as they are spring-forced by themselves. Also, the distance between the opening/closing stationary and movable contacts 31 and 57

is smaller than that between the conducting stationary and movable contacts 32 and 58. Then, the movement of the distal end of the movable contact plate assembly 50 by the actuator plate 70 closes between the opening/closing movable and stationary contacts 57 and 31 and, subsequently, between the conducting movable and stationary contacts 58 and 32.

[0071] Accordingly, this arrangement provides not only various advantages similar to the first embodiment of the invention but also another advantage in which a larger bending moment acts on the opening/closing movable contact 57 due to the leverage motion derived from the movement of the actuator plate 70 and thereby increases the contact pressure.

[0072] Because other structures are substantially the same as the corresponding structures of the first embodiment, like parts are designated by like reference numerals and duplicate descriptions are eliminated.

[0073] The electromagnetic relay according to the fourth embodiment is substantially the same as the first embodiment, as shown in Fig. 14A to 14D, except that the actuator plate 70 has a forcing projection 73a formed in an inner surface portion defining the engaging slot 73, which is elevated than a contact region of the first divided plate portion 55 of the movable contact plate assembly 50.

[0074] According to this embodiment, the sliding movement of the actuator plate 70 forces the first divided plate portion 55 first, which closes between the opening/closing movable and stationary contacts 57 and 31 and, subsequently, between the conducting movable and stationary contacts 58 and 32.

[0075] Accordingly, this arrangement provides not only various advantages similar to the first embodiment of the invention but also another advantage in which only the height adjustment of the forcing projection 73a of the actuator plate 70 ensures a desired contact pressure and tends to obtain a desired operating characteristic.

[0076] Because other structures are substantially the same as the corresponding structures of the first embodiment, like parts are designated by like reference numerals and duplicate descriptions are eliminated.

[0077] The electromagnetic relay according to the fifth embodiment is substantially the same as the first embodiment, as shown in Fig. 15A to 15D, except that the first divided plate portion 55 of the movable contact plate assembly 50 is configured so that it is closer to the stationary contact terminal 30 than the second divided plate portion 56.

[0078] According to this embodiment, the sliding movement of the actuator plate 70 closes between the opening/closing movable and stationary contacts 57 and 31 and, subsequently, between the conducting movable and stationary contacts 58 and 32.

[0079] Accordingly, this arrangement provides not only various advantages similar to the first embodiment of the invention but also another advantage that the electromagnetic relay capable of being adjusted easily and with

a reduced variation in operating characteristic by bending the first and second divided plate portions 55 and 56.

[0080] Because other structures are substantially the same as the corresponding structures of the first embodiment, like parts are designated by like reference numerals and duplicate descriptions are eliminated.

[0081] It should be noted that one of the bent portions 51g of the first movable contact plate 51 may be bent toward the movable contact terminal 40 more than the other of the bent portions 51g, shifting the closing timing of the opening/closing movable contact 57.

[0082] The electromagnetic relay according to the invention is not limited to that described above, and the invention can be applied to various electromagnetic relays and electronic devices.

DESCRIPTION OF REFERENCE SYMBOLS

[0083]

- 10 base
- 11 partition wall
- 12a, 12b terminal slit
- 13 fitting groove
- 13a stepped portion
- 13b collecting recess
- 20 electromagnetic unit
- 21 spool
- 22 coil
- 23 iron core
- 24 yoke
- 24a magnetic pole
- 25 yoke
- 25a magnetic pole
- 30 stationary contact terminal
- 31 opening/closing stationary contact
- 32 conducting stationary contact
- 33 terminal portion
- 40 opening/closing movable contact
- 41 fixing projection
- 42 terminal portion
- 50 movable contact plate assembly
- 50a cutout
- 51 first movable contact plate
- 51f aperture
- 51g bent portion
- 52 second movable contact plate
- 53 third movable contact plate
- 54 fourth movable contact plate
- 54f press fitting projection
- 55a fold portion
- 57 opening/closing movable contact
- 58 conducting movable contact
- 60 rotatable actuator
- 61 first movable iron plate
- 62 second movable iron plate
- 63 rotating shaft
- 64 rotating shaft

- 65 operation arm
- 70 actuator plate
- 71 engaging hole
- 72 engaging arm
- 5 73 engaging slot
- 74 positioning projection
- 80 position regulating plate
- 90 cover

10

Claims

- 1. An electromagnetic relay in which a movable contact plate unit (50) having a plurality of stacked movable contact plates (51, 52, 53, 54) is moved by an actuator plate (70) which moves reciprocatingly by magnetic force generated by an application of electric current to an electromagnetic unit (20) so that first and second movable contacts (57, 58) mounted on respective first and second divided plate portions (51a, 51b) extending in parallel in their longitudinal directions make and break contacts with respective first and second stationary contacts (31, 32) mounted on a stationary contact terminal (30), wherein the first stationary contact (31) is an opening/closing stationary contact and the second stationary contact (32) is a conducting stationary contact, and wherein the first movable contact (57) is an opening/closing movable contact and the second movable contact (58) is a conducting movable contact, **characterized in that** the first and second divided plate portions (51a, 51b) are bent at different portions to form respectively elastically deformable bent portions (51g) such that the bent portion (51g) supporting the conducting movable contact (58) in the second divided plate portion (51b) is shorter than the bent portion (51g) supporting the conducting movable contact (57) in the first divided plate portion (51a), which causes that the first movable contact (57) makes a contact with the first stationary contact (31) and then the second movable contact (58) makes a contact with the second stationary contact (32).
- 2. The electromagnetic relay according to claim 1, wherein a spring constant of the bent portion (51g) of the second divided plate portion (51b) is greater than that of the bent portion (51g) of the first divided plate portion (51a).
- 3. The electromagnetic relay according to any of claims 1 and 2, wherein a height of the first stationary contact (31) mounted on the stationary contact terminal (30) is greater than that of the second stationary contact (32) mounted on the stationary contact terminal (30).
- 4. The electromagnetic relay according to any one of

claims 1 and 2, wherein a region supporting the first stationary contact (31) is higher than a region supporting the second stationary contact (32).

5. The electromagnetic relay according to any of claims 1 and 2, wherein the second movable contact (58) is provided at a distal side of the second divided plate portion (51b) and the first movable contact (57) is provided at a proximal side of the first divided plate portion (51a).
6. The electromagnetic relay according to any of claims 1 and 2, wherein a region for forcing the first divided plate portion (51a) supporting the first movable contact (57) is higher than a region for forcing the second divided plate portion (51b) supporting the second movable contact (58).
7. The electromagnetic relay according to any of claims 1 and 2, wherein the first and second divided plate portions (51a, 51b) are bent in a manner such that the first movable contact (57) is closer to the first stationary contact (31) than the second movable contact (58).

Patentansprüche

1. Elektromagnetisches Relais, bei dem eine bewegliche Kontaktplatteneinheit (50) mit einer Vielzahl von gestapelten beweglichen Kontaktplatten (51, 52, 53, 54) durch eine Betätigungsplatte (70) bewegt wird, die sich durch eine magnetische Kraft, die durch Anlegen von elektrischem Strom an eine elektromagnetische Einheit (20) erzeugt wird, derart hin- und herbewegt, dass ein erster und ein zweiter beweglicher Kontakt (57, 58), die auf einem ersten und einem zweiten geteilten Plattenabschnitt (51a, 51b), die sich parallel in ihren Längsrichtungen erstrecken, montiert sind, einen jeweiligen ersten und zweiten stationären Kontakt (31, 32), die an einem stationären Kontaktanschluss (30) montiert sind, kontaktieren bzw. den Kontakt unterbrechen, wobei der erste stationäre Kontakt (31) ein öffnender/schließender stationärer Kontakt und der zweite stationäre Kontakt (32) ein leitender stationärer Kontakt ist, und wobei der erste bewegliche Kontakt (57) ein öffnender/schließender beweglicher Kontakt und der zweite bewegliche Kontakt (58) ein leitender beweglicher Kontakt ist,
dadurch gekennzeichnet, dass
der erste und der zweite geteilte Plattenabschnitt (51a, 51b) an unterschiedlichen Abschnitten gebogen sind, um jeweilige gebogene Abschnitte (51g) zu bilden, so dass der gebogene Abschnitt (51g), der den leitenden beweglichen Kontakt (58) in dem zweiten geteilten Plattenabschnitt (51b) trägt, kürzer ist als der gebogene Abschnitt (51g), der den leitenden

den beweglichen Kontakt (57) in dem ersten geteilten Plattenabschnitt (51a) trägt, was bewirkt, dass der erste bewegliche Kontakt (57) einen Kontakt mit dem ersten stationären Kontakt (31) herstellt und dann der zweite bewegliche Kontakt (58) einen Kontakt mit dem zweiten stationären Kontakt (32) herstellt.

2. Elektromagnetisches Relais nach Anspruch 1, wobei eine Federkonstante des gebogenen Abschnitts (51g) des zweiten geteilten Plattenabschnitts (51b) größer ist als die des gebogenen Abschnitts (51g) des ersten geteilten Plattenabschnitts (51a).
3. Elektromagnetisches Relais nach einem der Ansprüche 1 und 2, wobei eine Höhe des ersten stationären Kontakts (31), der an dem stationären Kontaktanschluss (30) montiert ist, größer ist als die des zweiten stationären Kontakts (32), der an dem stationären Kontaktanschluss (30) montiert ist.
4. Elektromagnetisches Relais nach einem der Ansprüche 1 und 2, wobei ein Bereich, der den ersten stationären Kontakt (31) trägt, höher ist als ein Bereich, der den zweiten stationären Kontakt (32) trägt.
5. Elektromagnetisches Relais nach einem der Ansprüche 1 und 2, wobei der zweite bewegliche Kontakt (58) an einer distalen Seite des zweiten geteilten Plattenabschnitts (51b) vorgesehen ist und der erste bewegliche Kontakt (57) an einer proximalen Seite des ersten geteilten Plattenabschnitts (51a) vorgesehen ist.
6. Elektromagnetisches Relais nach einem der Ansprüche 1 und 2, wobei ein Bereich zur Kraftausübung auf den ersten geteilten Plattenabschnitt (51a), der den ersten beweglichen Kontakt (57) trägt, höher ist als ein Bereich zum Kraftausüben auf den zweiten geteilten Plattenabschnitt (51b), der den zweiten beweglichen Kontakt (58) trägt.
7. Elektromagnetisches Relais nach einem der Ansprüche 1 und 2, wobei der erste und der zweite geteilte Plattenabschnitt (51a, 51b) so gebogen sind, dass der erste bewegliche Kontakt (57) näher am ersten stationären Kontakt (31) liegt als der zweite bewegliche Kontakt (58).

Revendications

1. Relais électromagnétique dans lequel une unité de plaques de contact mobiles (50) qui comporte une pluralité de plaques de contact mobiles empilées (51, 52, 53, 54) est déplacée par une plaque d'actionneur (70) qui est déplacée en va-et-vient par une force magnétique qui est générée par une applica-

tion de courant électrique sur une unité électromagnétique (20) de telle sorte que des premier et second contacts mobiles (57, 58) qui sont montés sur des première et seconde parties de plaque divisées respectives (51a, 51b) qui s'étendent parallèlement à leurs directions longitudinales établissent et rompent des contacts avec des premier et second contacts stationnaires respectifs (31, 32) qui sont montés sur une borne de contact stationnaire (30), dans lequel le premier contact stationnaire (31) est un contact stationnaire d'ouverture/de fermeture et le second contact stationnaire (32) est un contact stationnaire de conduction, et dans lequel le premier contact mobile (57) est un contact mobile d'ouverture/de fermeture et le second contact mobile (58) est un contact mobile de conduction ;

caractérisé en ce que les première et seconde parties de plaque divisées (51a, 51b) sont fléchies au niveau de différentes parties pour former des parties fléchies pouvant être déformées élastiquement (51g) de telle sorte que la partie fléchie (51g) qui supporte le contact mobile de conduction (58) dans la seconde partie de plaque divisée (51b) soit plus courte que la partie fléchie (51g) qui supporte le contact mobile de conduction (57) dans la première partie de plaque divisée (51a), ce qui a pour effet que le premier contact mobile (57) établit un contact avec le premier contact stationnaire (31) puis le second contact mobile (58) établit un contact avec le second contact stationnaire (32).

2. Relais électromagnétique selon la revendication 1, dans lequel une constante élastique de la partie fléchie (51g) de la seconde partie de plaque divisée (51b) est plus importante que celle de la partie fléchie (51g) de la première partie de plaque divisée (51a).

3. Relais électromagnétique selon l'une quelconque des revendications 1 et 2, dans lequel une hauteur du premier contact stationnaire (31) qui est monté sur la borne de contact stationnaire (30) est plus importante que celle du second contact stationnaire (32) qui est monté sur la borne de contact stationnaire (30).

4. Relais électromagnétique selon l'une quelconque des revendications 1 et 2, dans lequel une région qui supporte le premier contact stationnaire (31) est plus haute qu'une région qui supporte le second contact stationnaire (32).

5. Relais électromagnétique selon l'une quelconque des revendications 1 et 2, dans lequel le second contact mobile (58) est prévu au niveau d'un côté distal de la seconde partie de plaque divisée (51b) et le premier contact mobile (57) est prévu au niveau d'un côté proximal de la première partie de plaque divisée (51a).

6. Relais électromagnétique selon l'une quelconque des revendications 1 et 2, dans lequel une région pour forcer la première partie de plaque divisée (51a) qui supporte le premier contact mobile (57) est plus haute qu'une région pour forcer la seconde partie de plaque divisée (51b) qui supporte le second contact mobile (58).

7. Relais électromagnétique selon l'une quelconque des revendications 1 et 2, dans lequel les première et seconde parties de plaque divisées (51a, 51b) sont fléchies d'une manière qui est telle que le premier contact mobile (57) est plus proche du premier contact stationnaire (31) que le second contact mobile (58) .

Fig. 1A

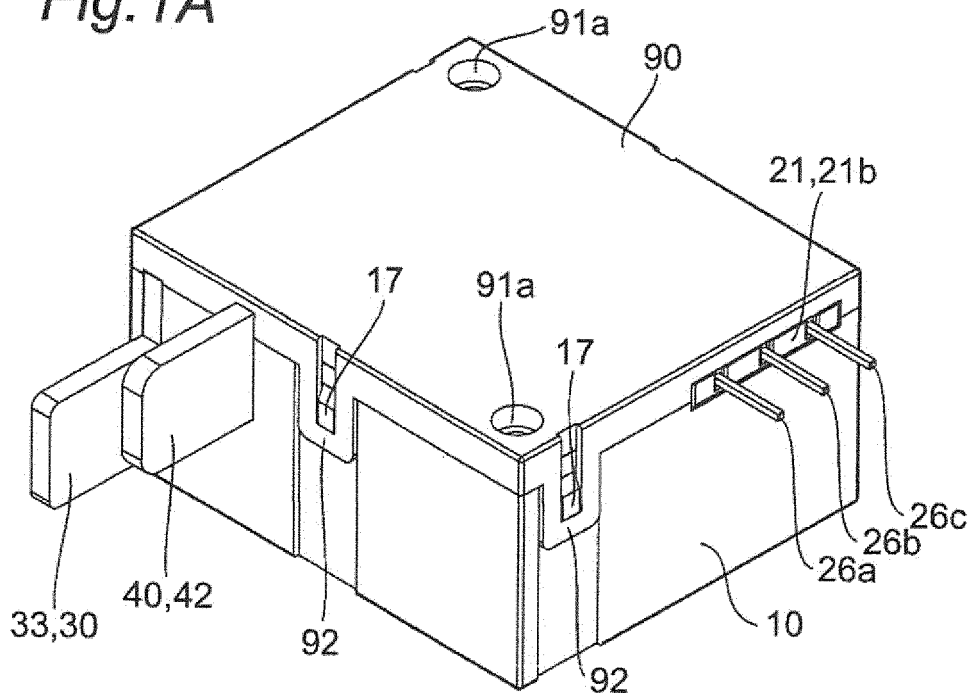

Fig. 1B

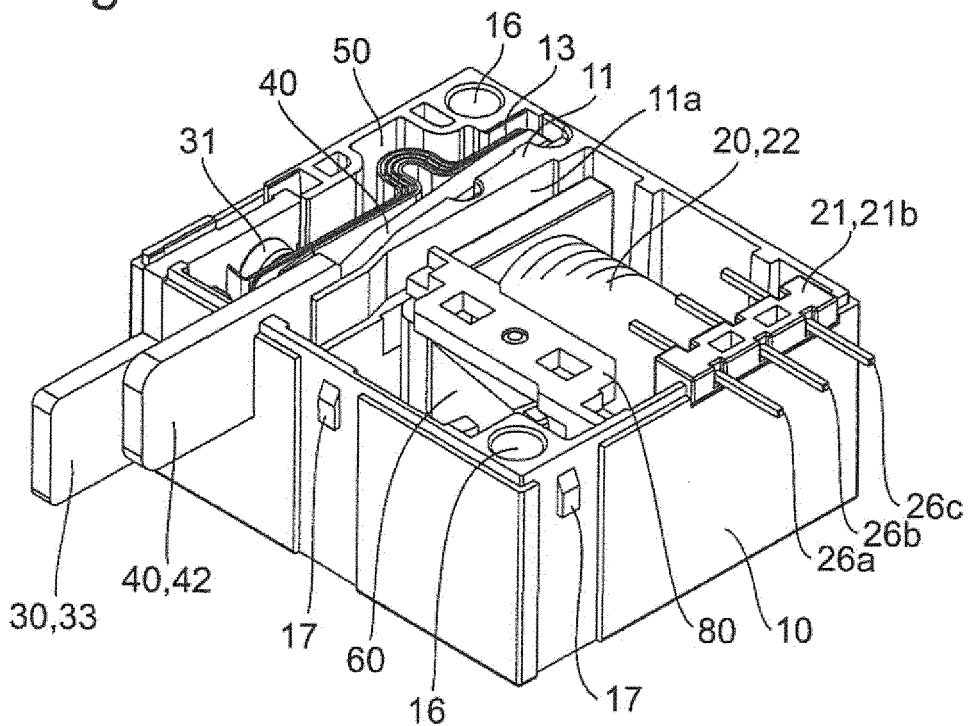

Fig. 2A

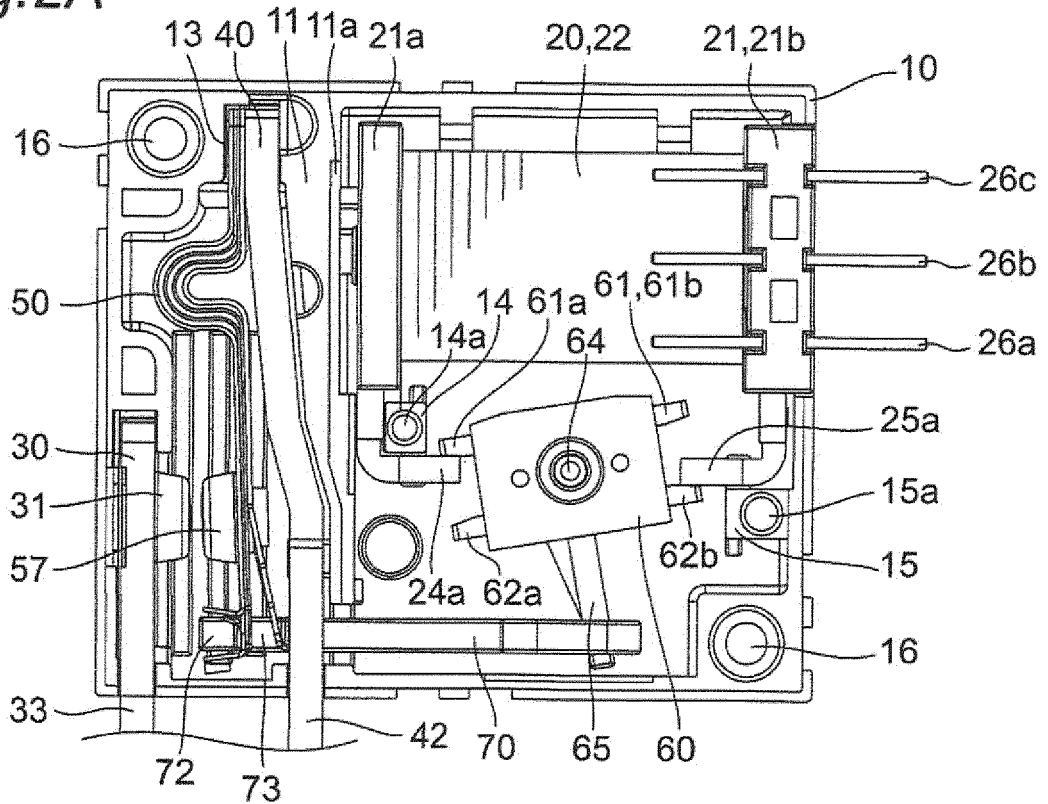

Fig. 2B

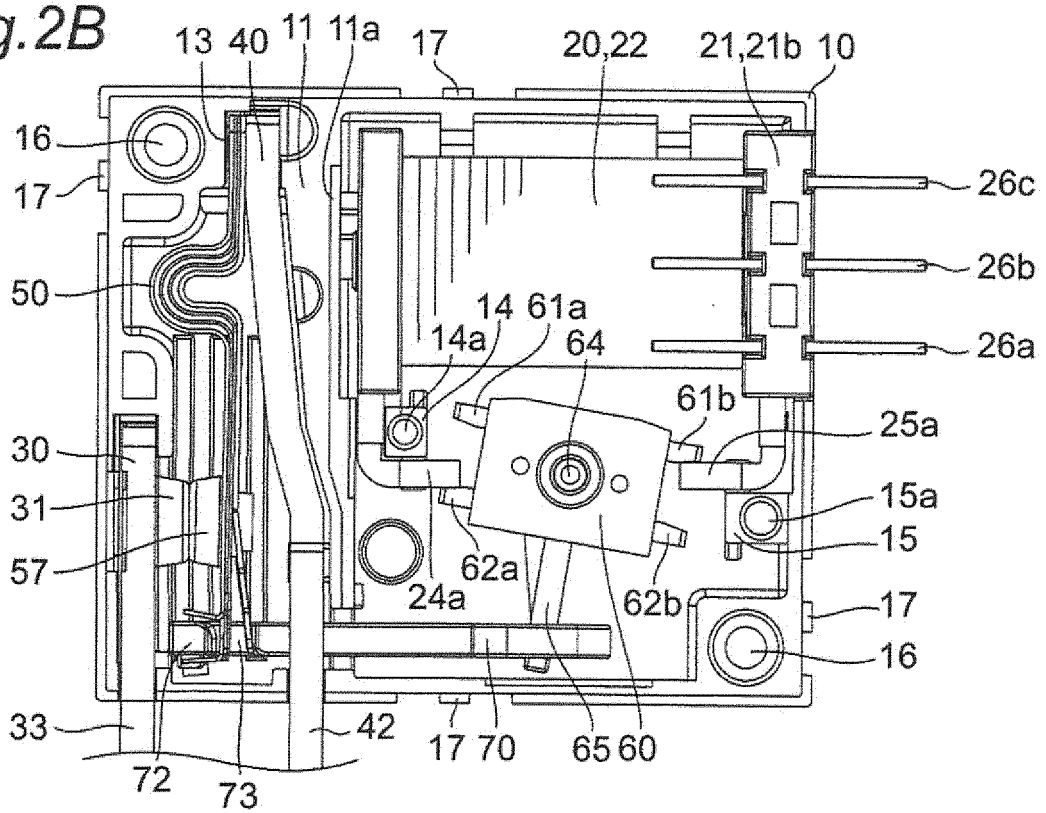

Fig.3

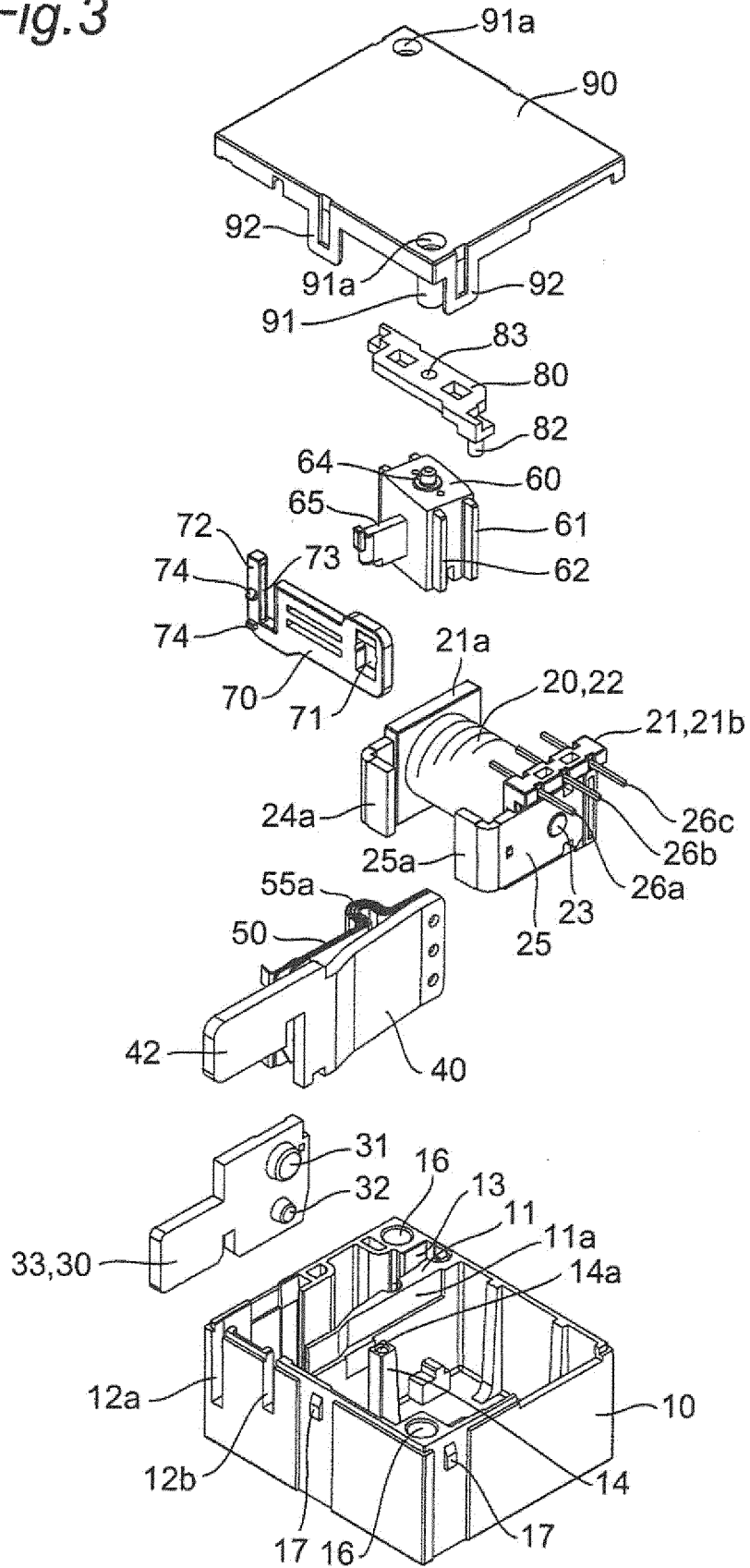

Fig.4

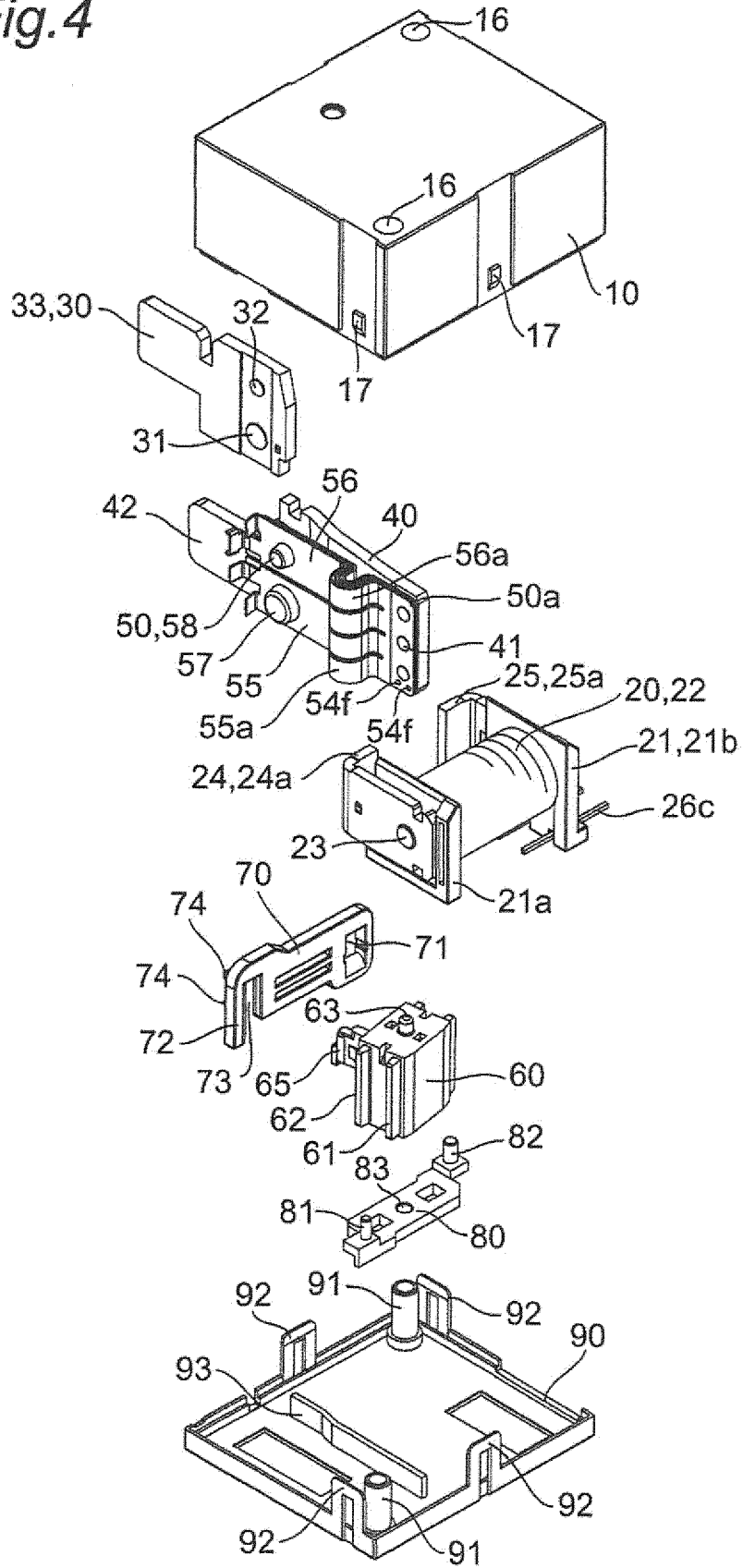

Fig.5A

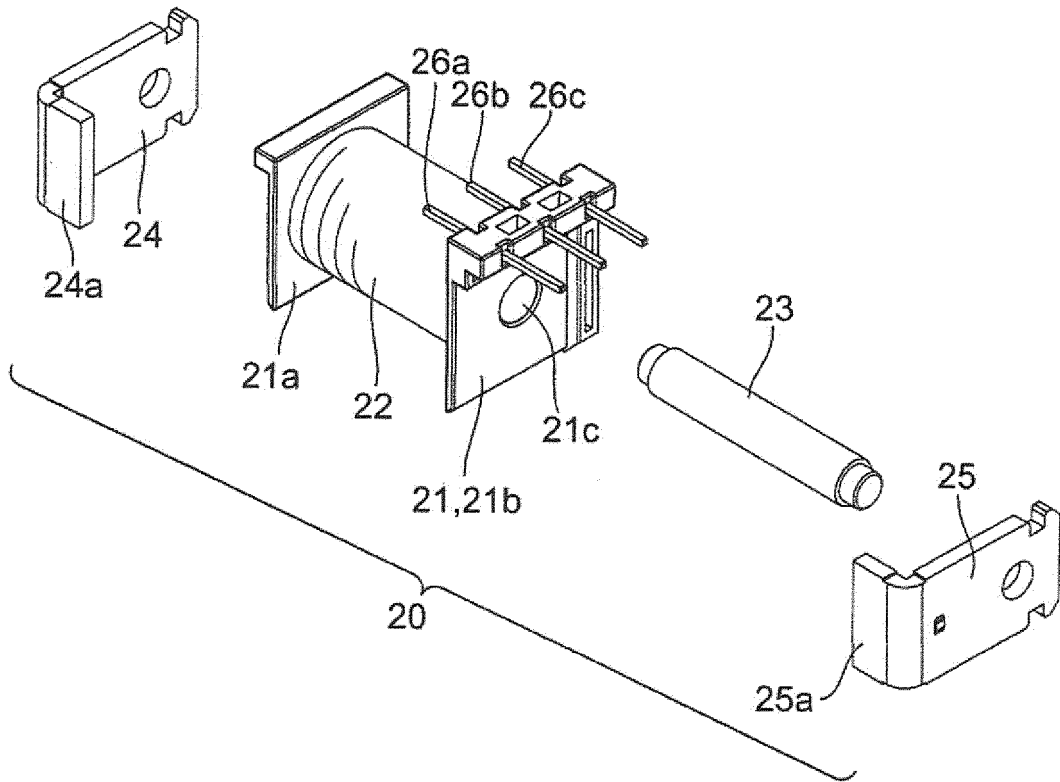

Fig.5B

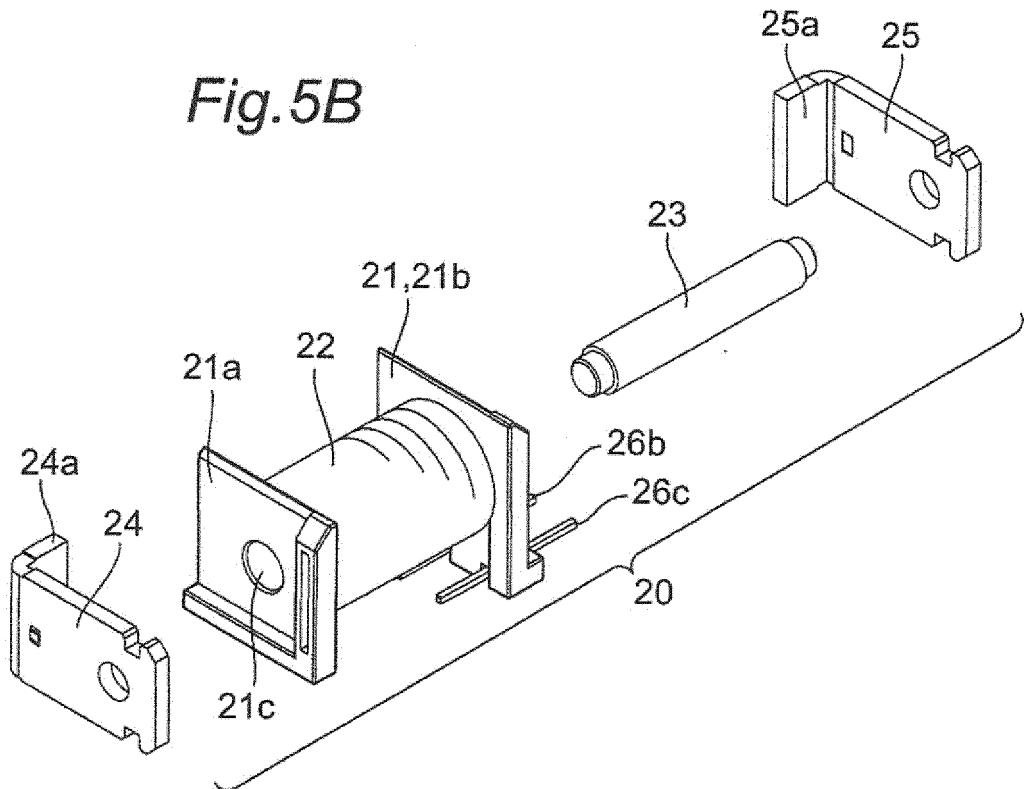

Fig. 6A

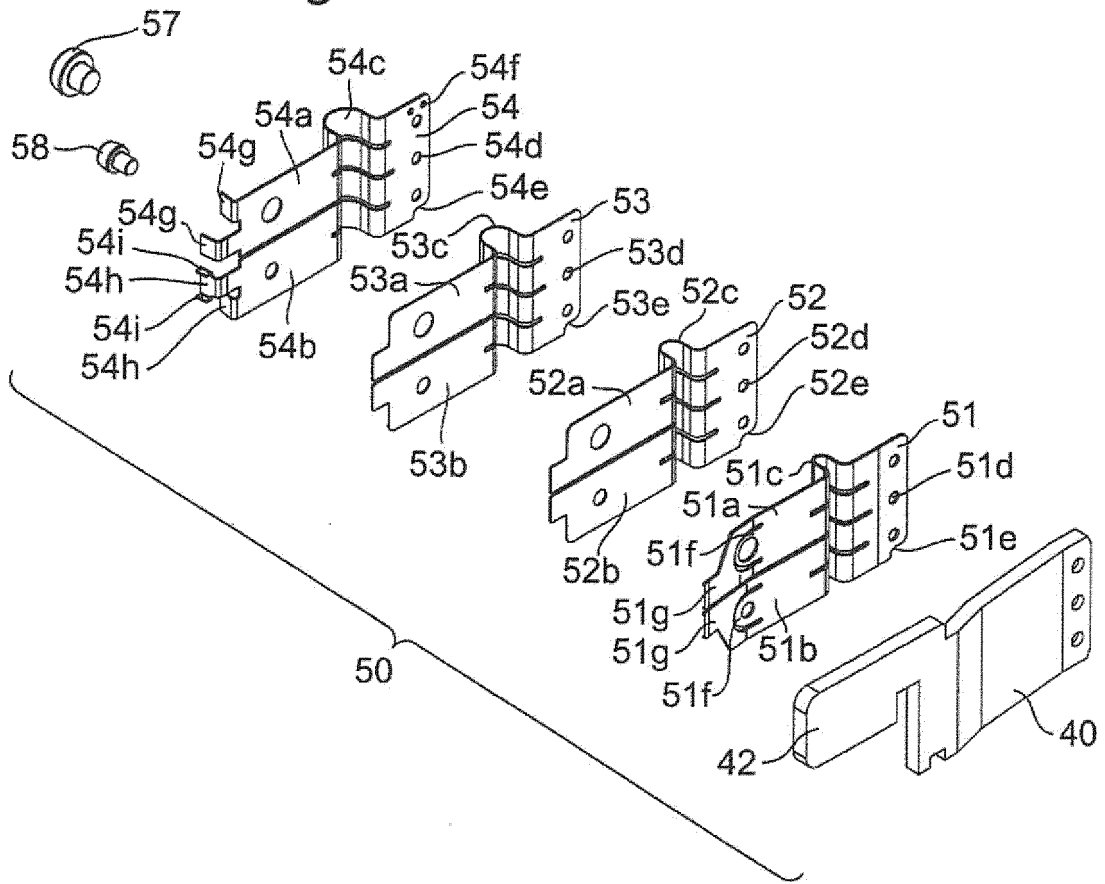

Fig. 6B

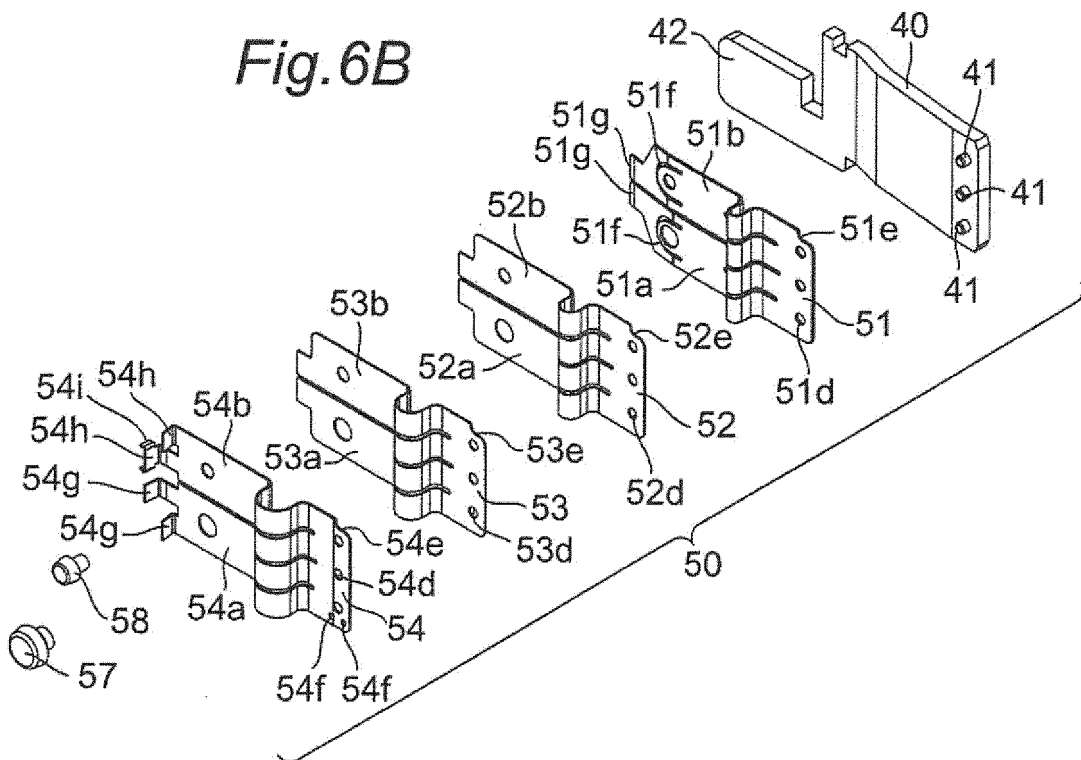

Fig. 7A

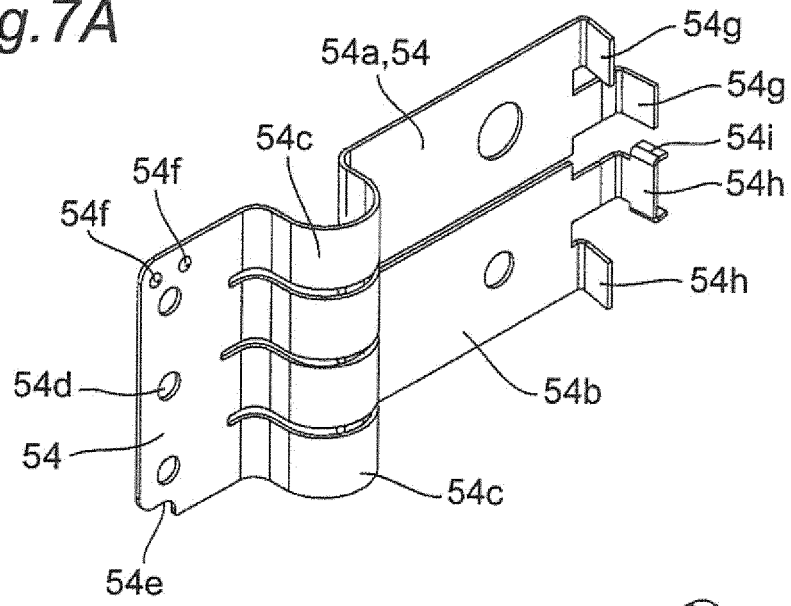

Fig. 7B

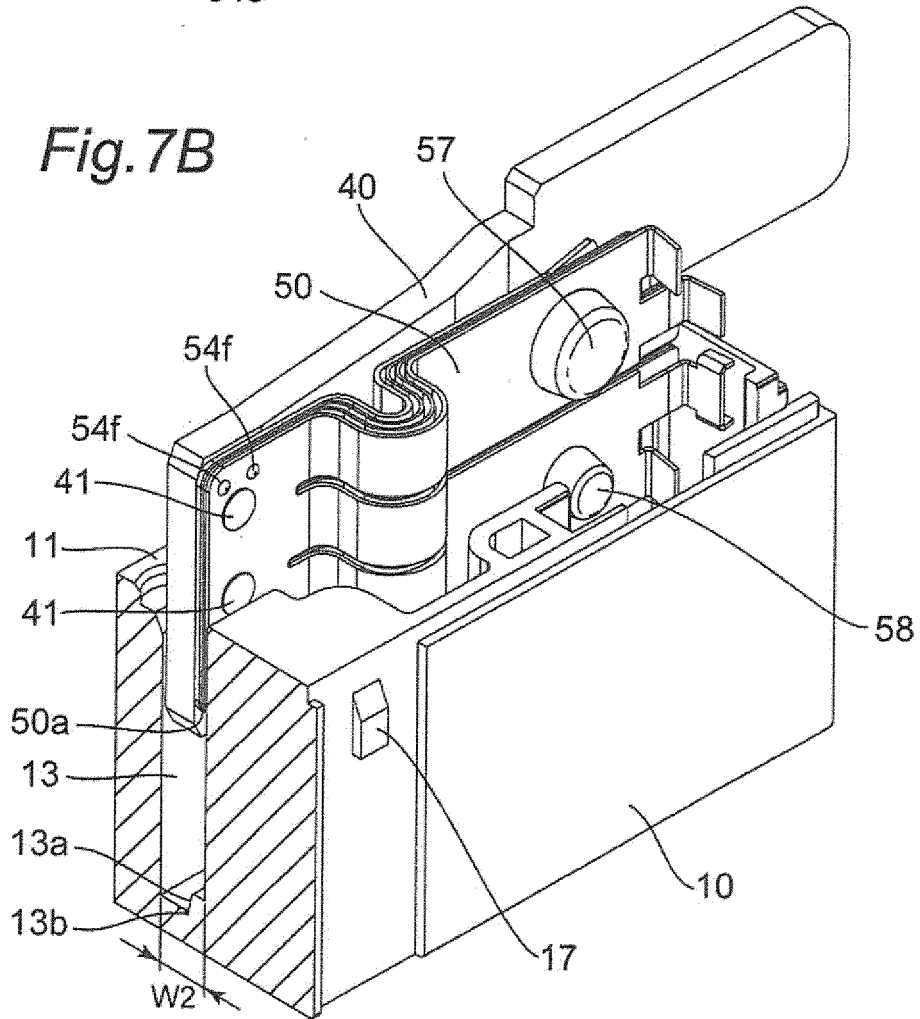

Fig. 8A

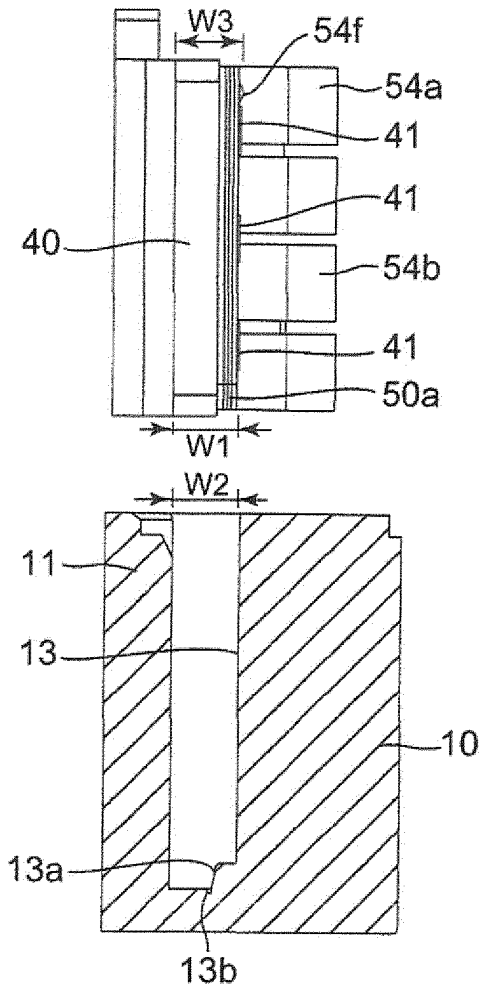

Fig. 8B

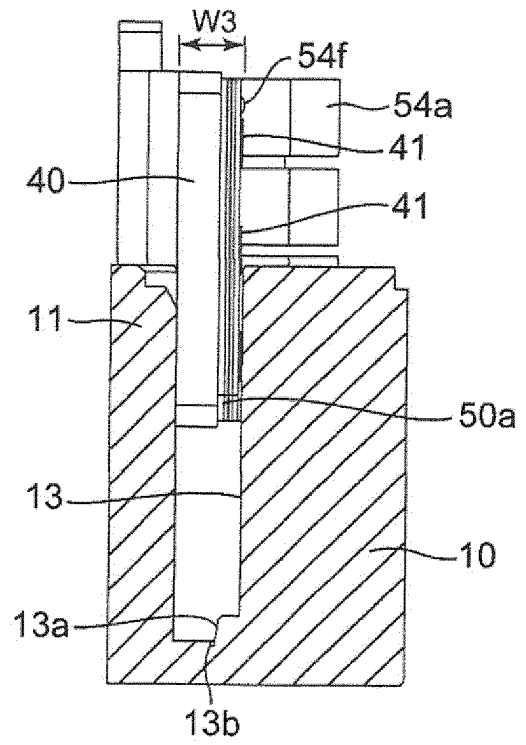

Fig. 8C

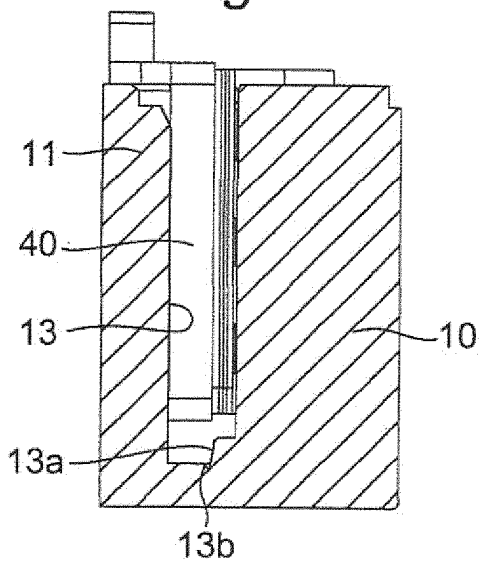

Fig. 8D

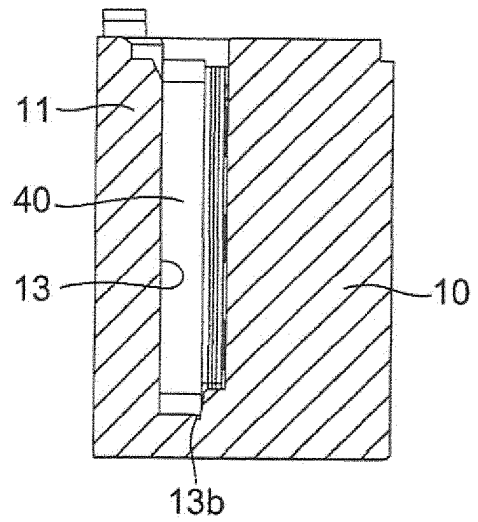

Fig.9A

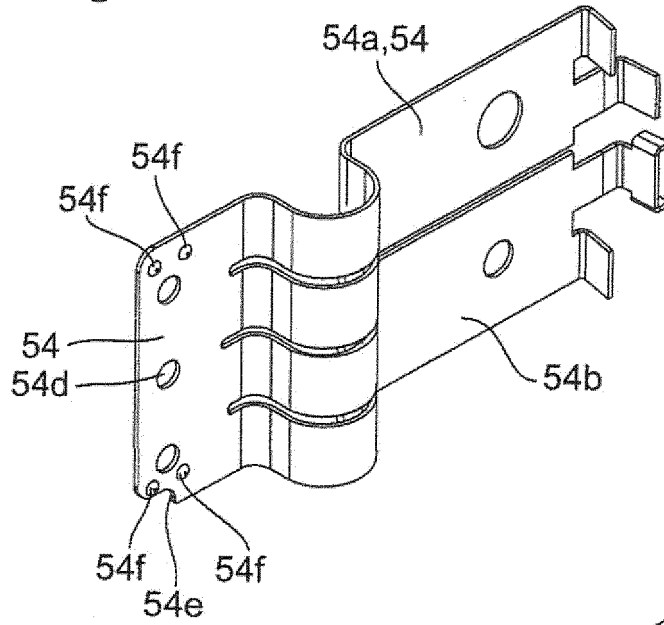

Fig.9B

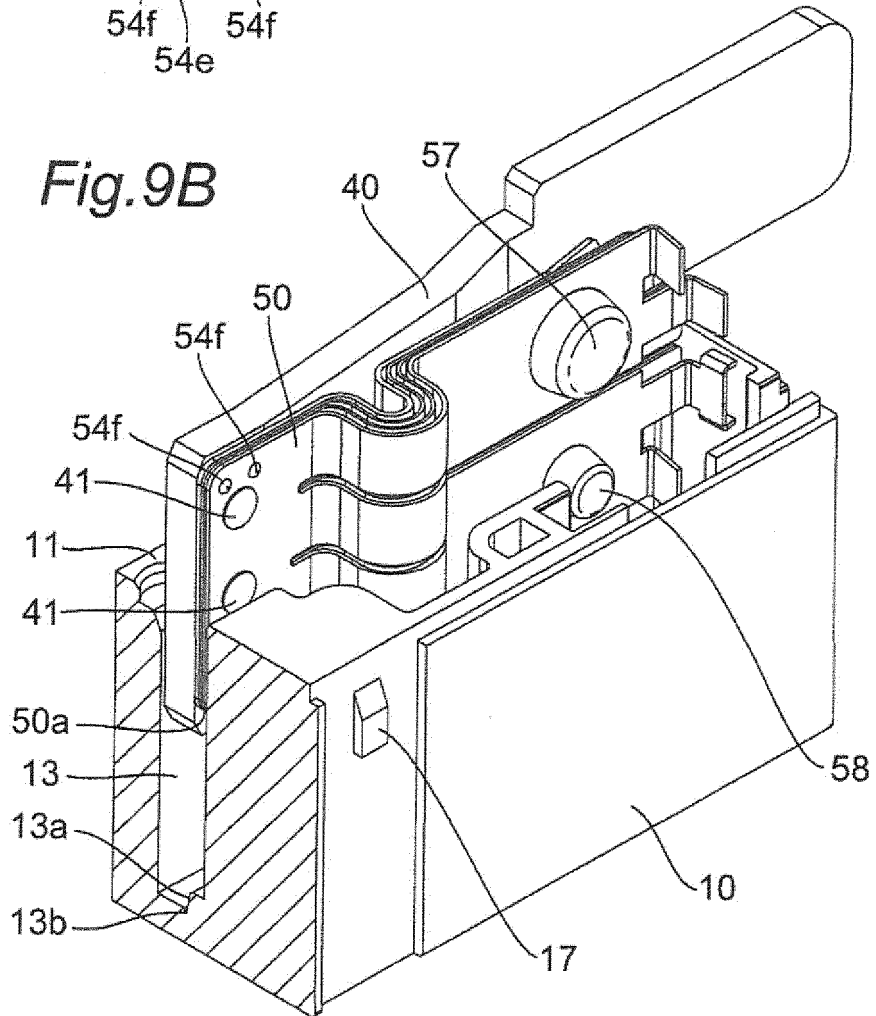

Fig. 10A

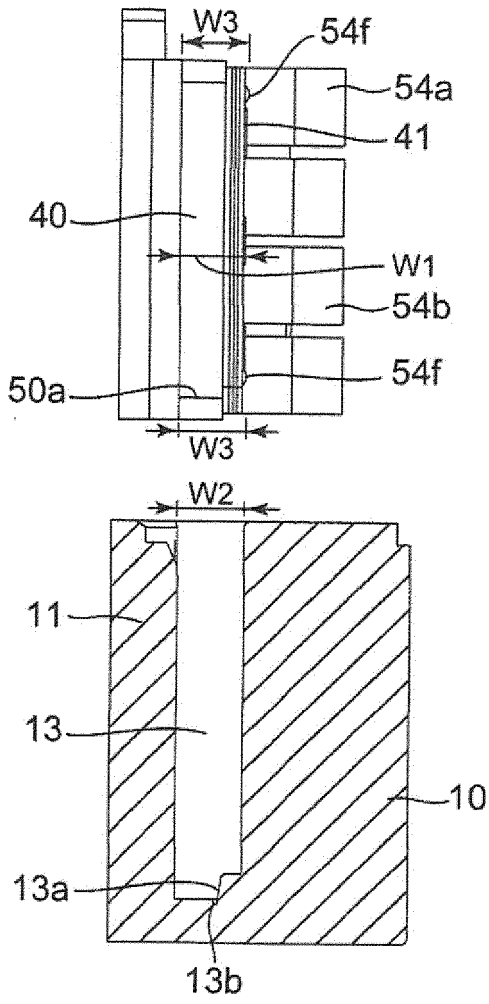

Fig. 10B

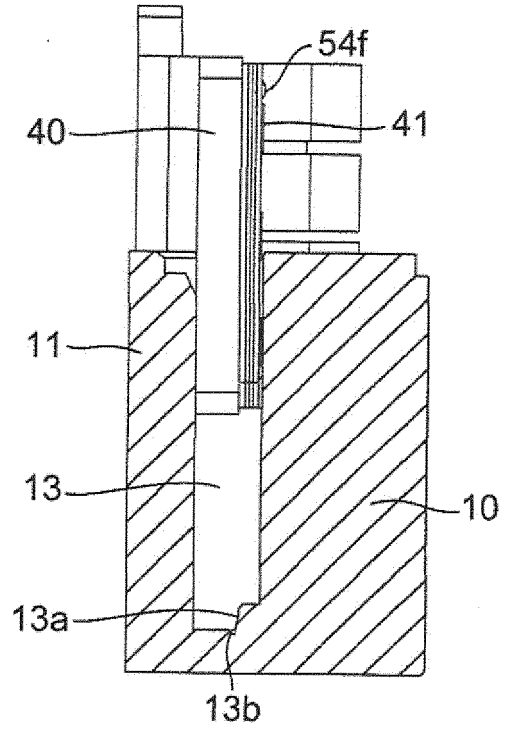

Fig. 10C

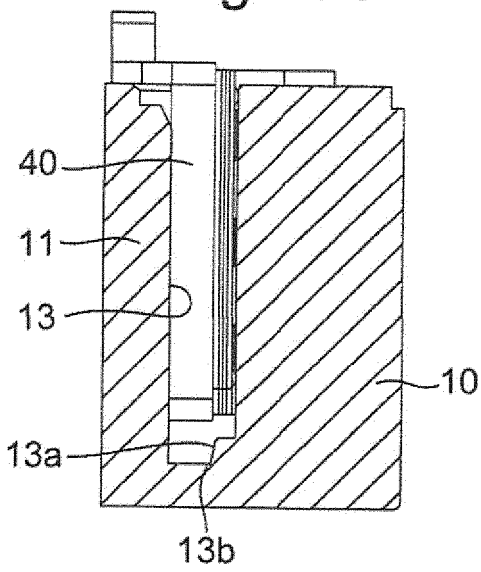

Fig. 10D

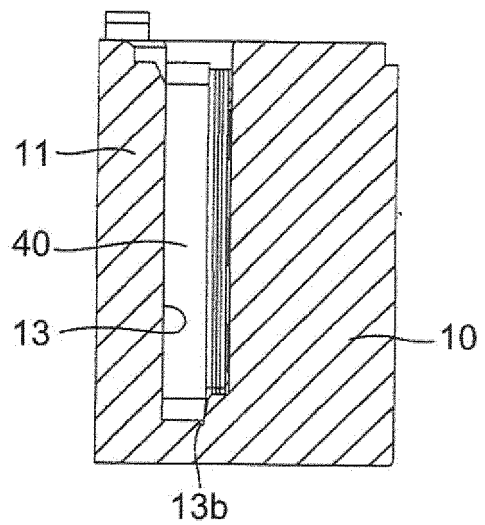

Fig.11A

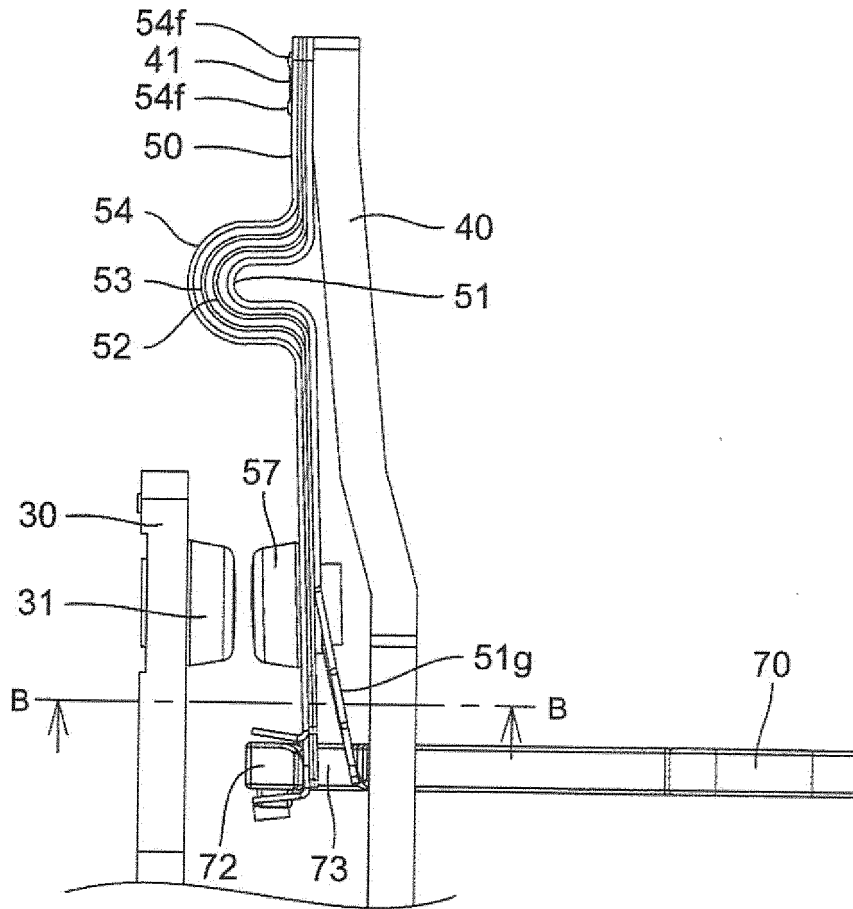

Fig.11B

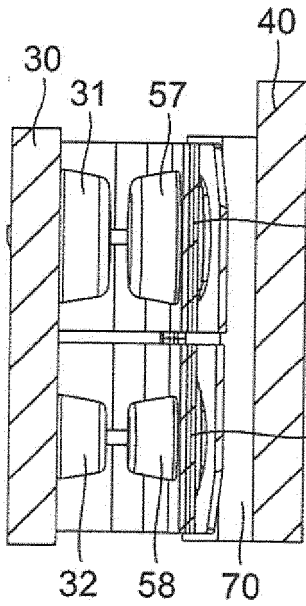

Fig.11C

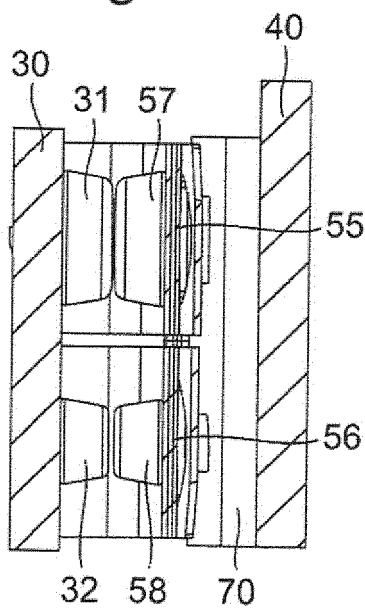

Fig.11D

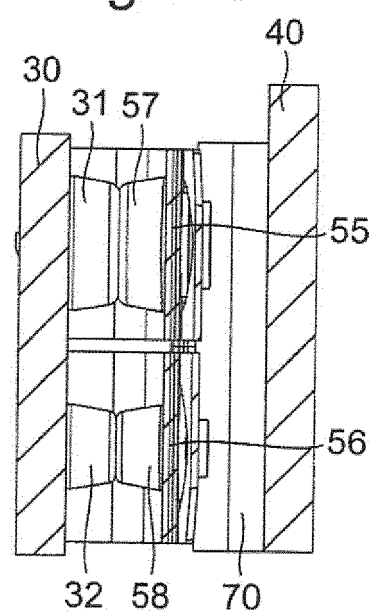

Fig.12A

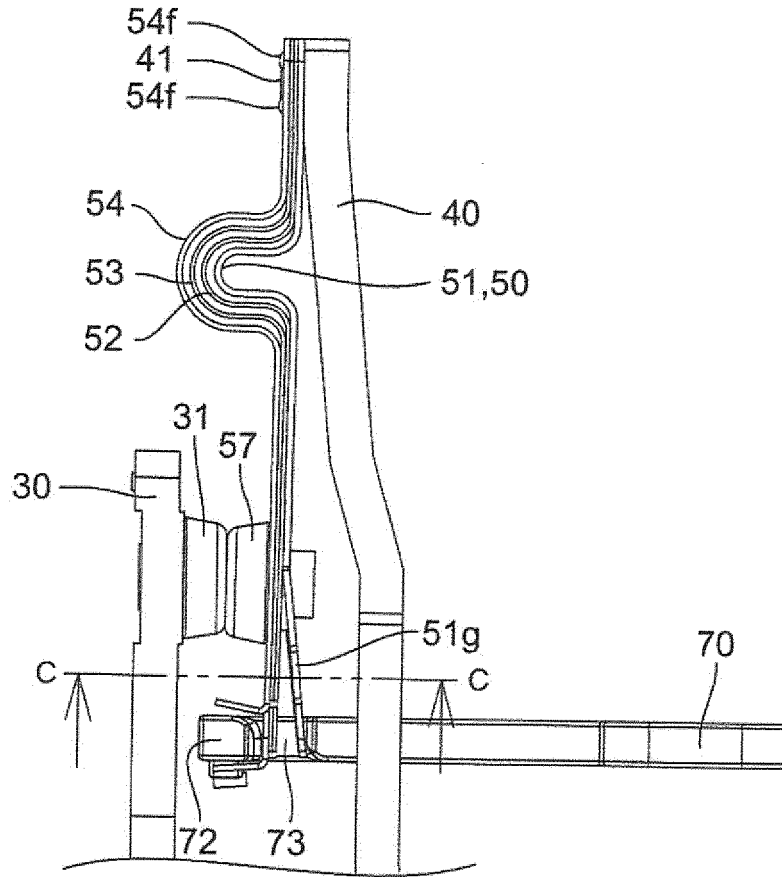

Fig.12B

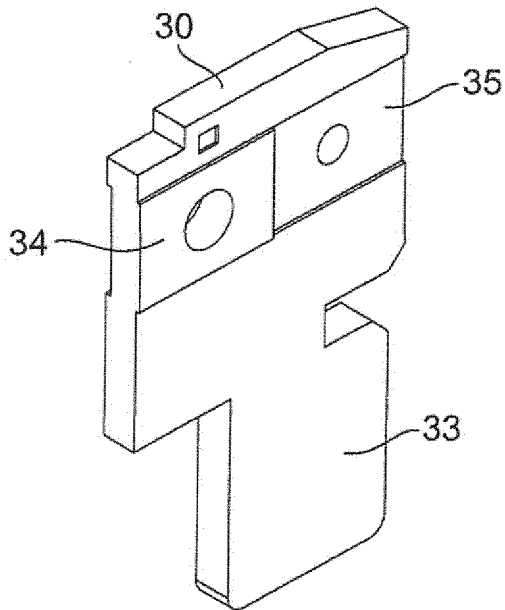

Fig.12C

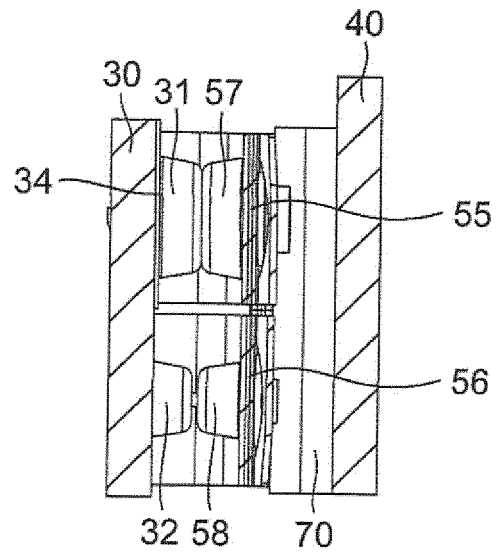

Fig.13B

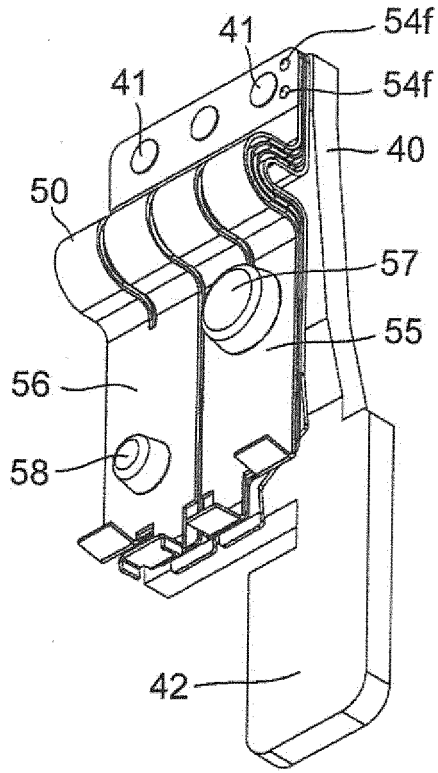

Fig.13A

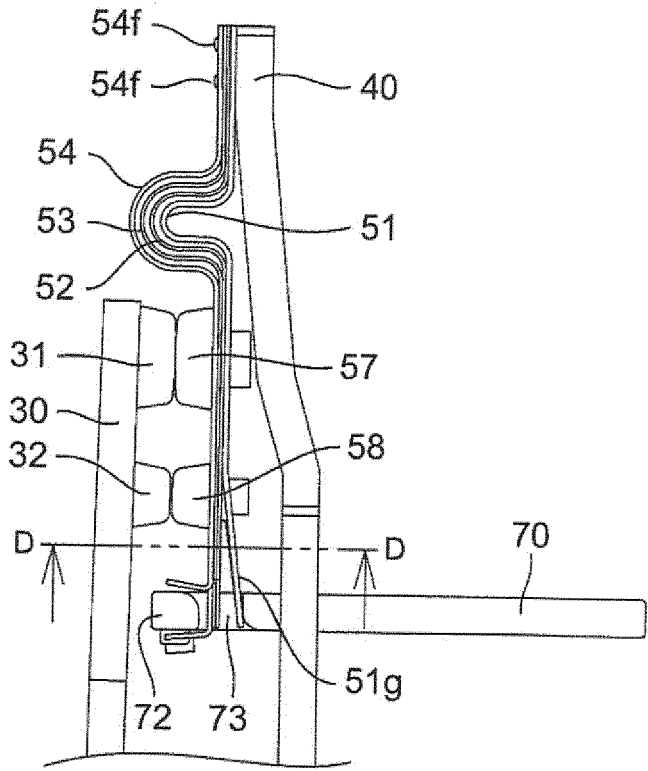

Fig.13C

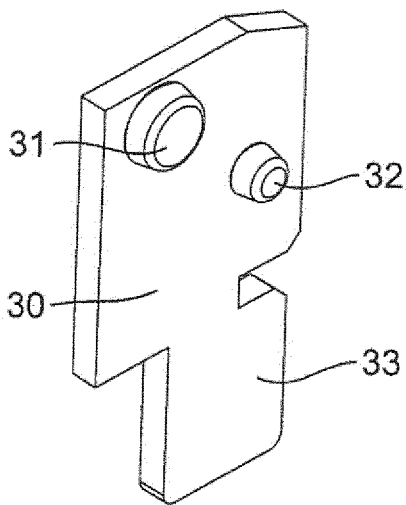

Fig.13D

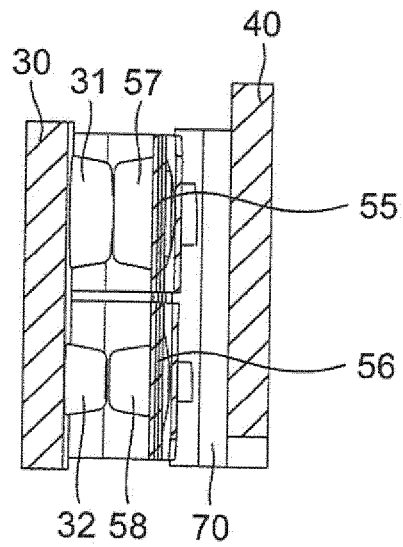

Fig. 14C

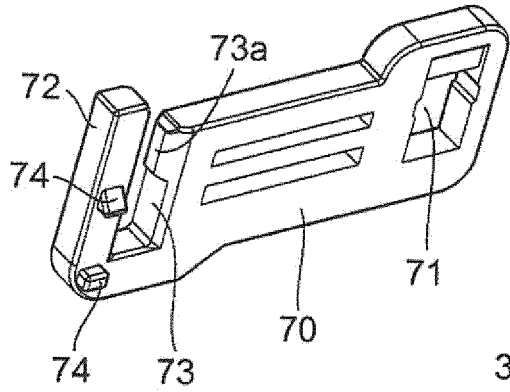

Fig. 14A

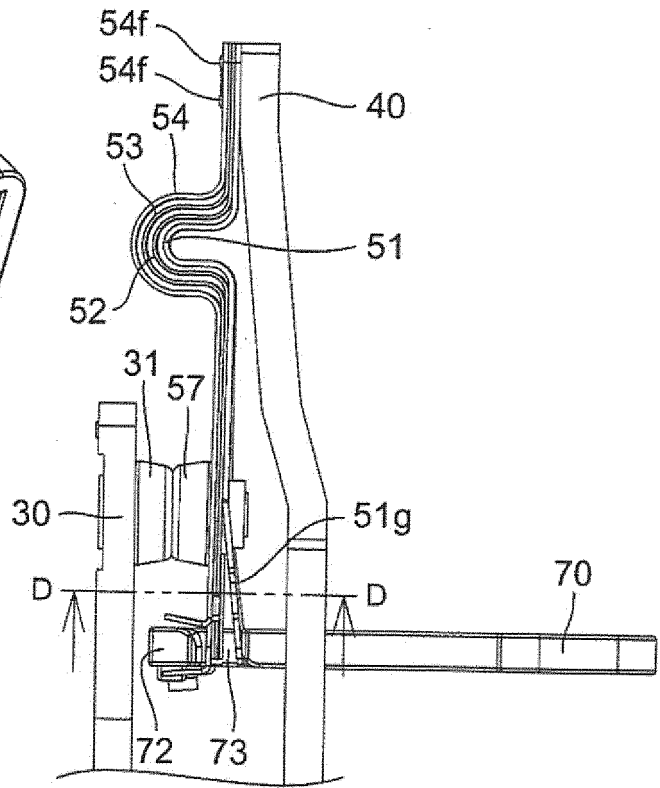

Fig. 14D

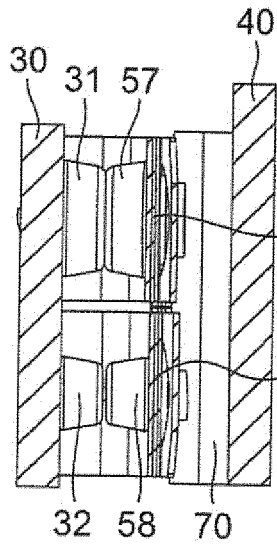

Fig. 14B

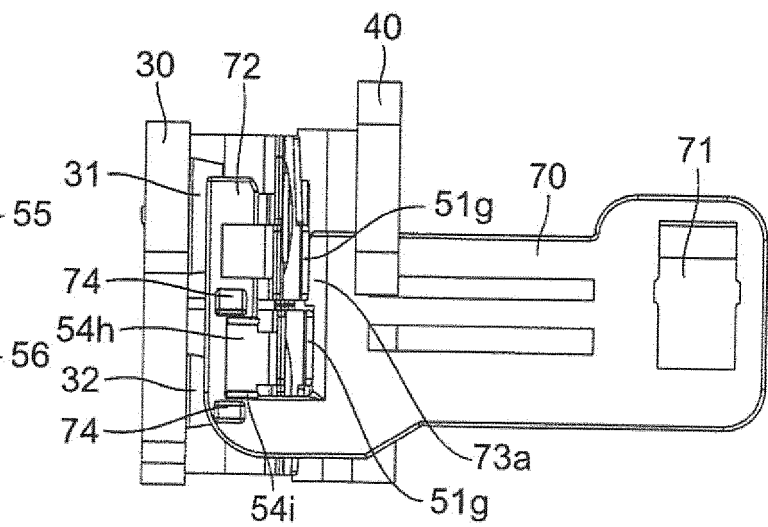

Fig. 15C

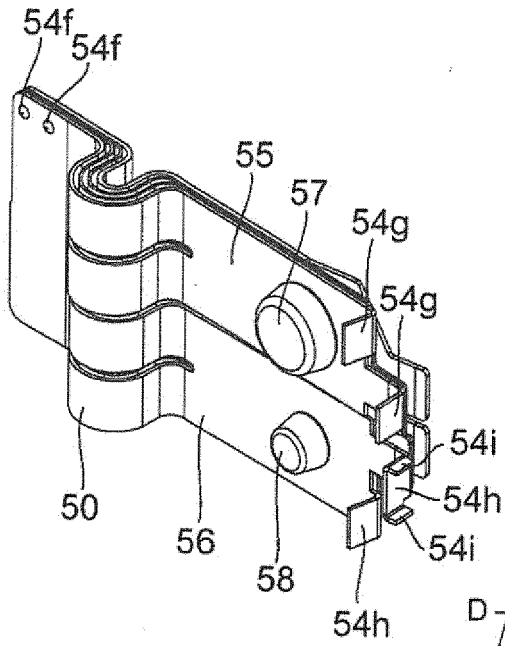

Fig. 15A

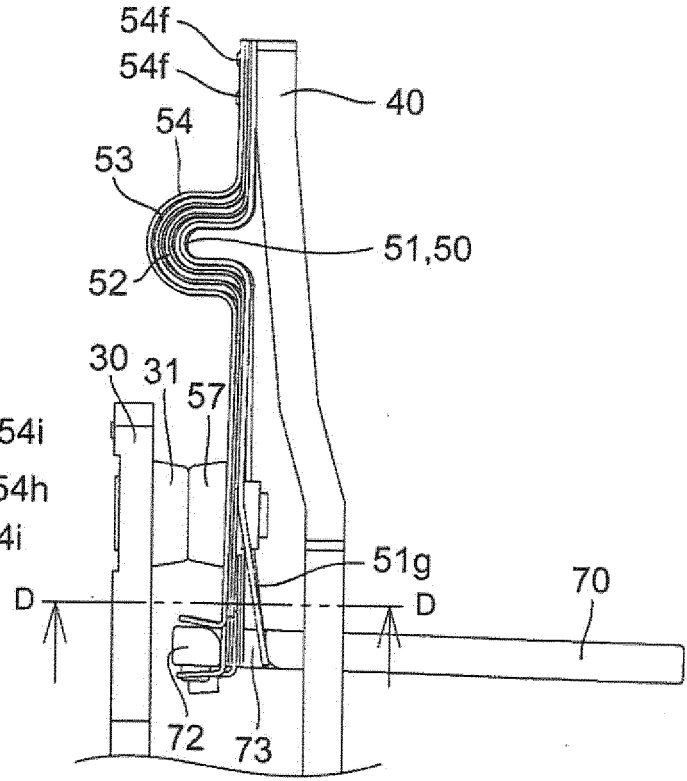

Fig. 15D

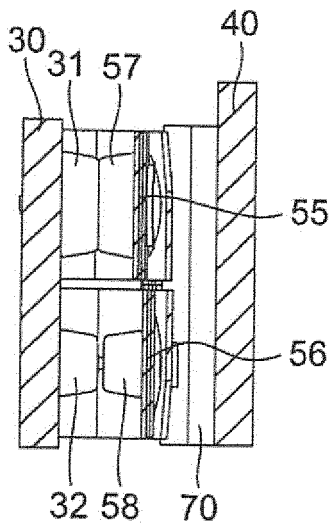
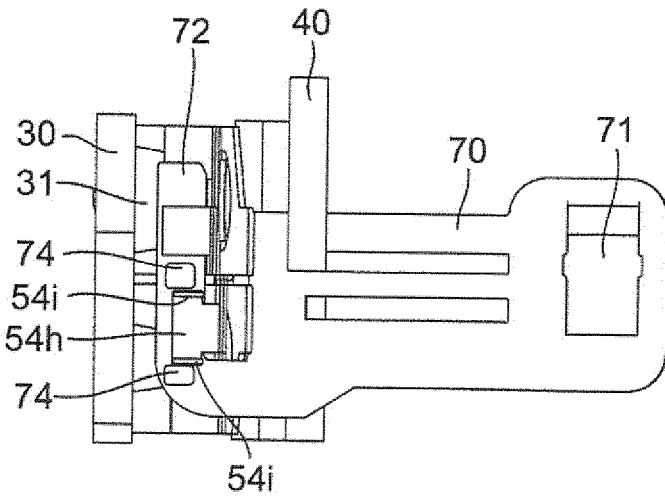

Fig. 15B



REFERENCES CITED IN THE DESCRIPTION

This list of references cited by the applicant is for the reader's convenience only. It does not form part of the European patent document. Even though great care has been taken in compiling the references, errors or omissions cannot be excluded and the EPO disclaims all liability in this regard.

Patent documents cited in the description

- US 7659800 B [0003]
- US 20090033446 A1 [0006]
- DE 9404775 U1 [0007]
- JP 2002008506 A [0007]
- JP 2005183097 A [0007]
- JP H027840 U [0007]