

(19) AUSTRALIAN PATENT OFFICE

(54) Title
Improvements relating to filter-tip cigarettes and method of manufacturing same

(51)⁶ International Patent Classification(s)
A24C 5/47 (2006.01) 20060101ALI2005100
A24D 3/04 (2006.01) 8BMEP **D21H**
D21H 17/67 (2006.01) 17/67
D21H 27/00 (2006.01) 20060101ALI2006031
A24C 5/47 OBMJP **D21H**
20060101AFI2006031 27/00
OBMJP **A24D** 20060101ALI2006031
3/04 OBMJP
PCT/GB2003/003430

(21) Application No: 2003249076 (22) Application Date: 2003 .08 .07

(87) WIPO No: W004/014161

(30) Priority Data

(31) Number	(32) Date	(33) Country
102 36 655.1	2002 .08 .09	DE

(43) Publication Date : 2004 .02 .25

(43) Publication Journal Date : 2004 .04 .08

(71) Applicant(s)
British American Tobacco (Investments) Limited

(72) Inventor(s)
Grzonka, Horst

(74) Agent/Attorney
Shelston IP, Level 21 60 Margaret Street, Sydney, NSW, 2000

(56) Related Art
WO 00/53037
US 5662126
GB 1019092
US 4675064

(12) INTERNATIONAL APPLICATION PUBLISHED UNDER THE PATENT COOPERATION TREATY (PCT)

(19) World Intellectual Property
Organization
International Bureau



(43) International Publication Date
19 February 2004 (19.02.2004)

PCT

(10) International Publication Number
WO 2004/014161 A1

- (51) International Patent Classification⁷: **A24D 3/04**
- (21) International Application Number:
PCT/GB2003/003430
- (22) International Filing Date: 7 August 2003 (07.08.2003)
- (25) Filing Language: English
- (26) Publication Language: English
- (30) Priority Data:
102 36 655.1 9 August 2002 (09.08.2002) DE
- (71) Applicant (for all designated States except US): **BRITISH AMERICAN TOBACCO (INVESTMENTS) LIMITED** [GB/GB]; Globe House, 1 Water Street, London WC2R 3LA (GB).
- (72) Inventor; and
(75) Inventor/Applicant (for US only): **GRZONKA, Horst** [DE/DE]; Brauergasse 1 (Obersees), 95490 Mistelgau (DE).
- (74) Agent: **WALFORD, Margot, Ruth**; British American Tobacco R & D Centre, Patents Department, Regents Park Road, Southampton SO15 8TL (GB).
- (81) Designated States (national): AE, AG, AL, AM, AT, AU, AZ, BA, BB, BG, BR, BY, BZ, CA, CH, CN, CO, CR, CU, CZ, DE, DK, DM, DZ, EC, EE, ES, FI, GB, GD, GE, GH, GM, HR, HU, ID, IL, IN, IS, JP, KE, KG, KP, KR, KZ, LC, LK, LR, LS, LT, LU, LV, MA, MD, MG, MK, MN, MW, MX, MZ, NI, NO, NZ, OM, PG, PH, PL, PT, RO, RU, SC, SD, SE, SG, SK, SL, SY, TJ, TM, TN, TR, TT, TZ, UA, UG, US, UZ, VC, VN, YU, ZA, ZM, ZW.
- (84) Designated States (regional): ARIPO patent (GH, GM, KE, LS, MW, MZ, SD, SL, SZ, TZ, UG, ZM, ZW), Eurasian patent (AM, AZ, BY, KG, KZ, MD, RU, TJ, TM), European patent (AT, BE, BG, CH, CY, CZ, DE, DK, EE, ES, FI, FR, GB, GR, HU, IE, IT, LU, MC, NL, PT, RO, SE, SI, SK, TR), OAPI patent (BF, BJ, CF, CG, CI, CM, GA, GN, GQ, GW, ML, MR, NE, SN, TD, TG).
- Declarations under Rule 4.17:**
— as to applicant's entitlement to apply for and be granted a patent (Rule 4.17(ii)) for the following designations AE, AG, AL, AM, AT, AU, AZ, BA, BB, BG, BR, BY, BZ, CA, CH, CN, CO, CR, CU, CZ, DE, DK, DM, DZ, EC, EE, ES, FI, GB, GD, GE, GH, GM, HR, HU, ID, IL, IN, IS, JP, KE, KG, KP, KR, KZ, LC, LK, LR, LS, LT, LU, LV, MA, MD, MG, MK, MN, MW, MX, MZ, NI, NO, NZ, OM, PG, PH, PL, PT, RO, RU, SC, SD, SE, SG, SK, SL, SY, TJ, TM, TN, TR, TT, TZ, UA, UG, UZ, VC, VN, YU, ZA, ZM, ZW. ARIPO patent (GH, GM, KE, LS, MW, MZ, SD, SL, SZ, TZ, UG, ZM, ZW). Eurasian patent (AM, AZ, BY, KG, KZ, MD, RU, TJ, TM). European patent (AT, BE, BG, CH, CY, CZ, DE, DK, EE, ES, FI, FR, GB, GR, HU, IE, IT, LU, MC, NL, PT, RO, SE, SI, SK, TR). OAPI patent (BF, BJ, CF, CG, CI, CM, GA, GN, GQ, GW, ML, MR, NE, SN, TD, TG)
- as to the applicant's entitlement to claim the priority of the earlier application (Rule 4.17(iii)) for all designations
- Published:**
— with international search report
— before the expiration of the time limit for amending the claims and to be republished in the event of receipt of amendments
- For two-letter codes and other abbreviations, refer to the "Guidance Notes on Codes and Abbreviations" appearing at the beginning of each regular issue of the PCT Gazette.

(54) Title: IMPROVEMENTS RELATING TO FILTER-TIP CIGARETTES AND METHOD OF MANUFACTURING SAME

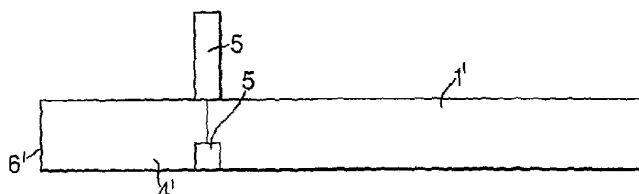

(57) Abstract: The invention relates to a filter-tip cigarette with a tobacco rod (1) wrapped in a cigarette paper and a filter (5) wrapped along its length in tipping paper (4) or other wrapper being other than plugwrap, and a strip of material (5) fully covering the tipping paper of the filter and the cigarette paper of the wrapped tobacco rod in the region of the abutment between tobacco rod and filter bonds together the filter and tobacco rod. In addition, the invention relates to a process for the manufacture of such a filter, which may also be employed for the manufacture of 'double unit cigarettes'.

WO 2004/014161 A1

Improvements relating to filter-tip cigarettes and method of manufacturing same

The invention relates to a filter-tip smoking articles and in particular, but not exclusively, to cigarettes, and to a method of manufacturing same.

Any discussion of the prior art throughout the specification should in no way be considered as an admission that such prior art is widely known or forms part of common general knowledge in the field.

Conventional filter-tip smoking articles, such as the cigarettes shown in Figures 1, 3 and 5 hereof, consist of a tobacco rod 1 wrapped in cigarette paper and a filter 6.

Cigarette filters are known in many different embodiments and generally consist of three components, namely:

- a) filtration material 2, usually of cylindrical shape, and being for example, cellulose acetate, paper, tobacco or similar materials or a combination of these materials, including perhaps additional material for filtering particular phases of the smoke, such as activated charcoal, for example,
- b) a paper 3 wrapped around and stabilising the filter, also known as plugwrap, and
- c) a filter tipping paper 4 (known hereafter as 'tipping' or 'tipping paper').

The plugwrap is placed around the filtration material 2 and glued during the manufacture of the filter in order to fix the structure of the filter and to ensure that the filter finished thus far can be transported without problem to the filter assembler, which is generally located immediately attached to the cigarette-manufacturing machine which supplies the tobacco rod.

As can be seen from Figure 3, the tipping is, as a rule, about 4 mm longer than the filter itself and is applied to the filter in the manufacture of the cigarette in the filter assembler. Because of its greater length the tipping overlaps a part of the tobacco rod and in this way interattaches the filter to the cigarette paper wrapped tobacco rod.

Besides fulfilling this bonding function the tipping must also be resistant to the moisture derived from the lips of the smoker, optionally be provided with ventilation holes, and finally satisfy certain design requirements by suitable fashioning, for example, printing.

In modern high-speed filter assembling machines the procedure shown in Figure 5 is used, making use of a double filter consisting of two filters 6 joined together. This double

filter is wrapped in a single piece of tipping 4 which projects slightly at the ends over the two filters 6, covering the plugwrap, so that the two tobacco rods 1 can be attached to the two ends of this double filter by the technique described above. After bonding the double filter to the two tobacco rods 1 the double filter is separated into two individual
5 filters 6 along the dotted line shown in Figure 5 to produce two filter-tip cigarettes.

A disadvantage of these known filter-tip cigarettes is the relatively expensive construction with the double wrapping of the filtration material 2 with plugwrap 3 and the tipping 4.

10 It is an object of the present invention to overcome or ameliorate at least one of the disadvantages of the prior art, or to provide a useful alternative.

Consequently it is an object of the present invention at least in a preferred form to provide a filter-tip cigarette of the given type and a method for its manufacture in which the above-mentioned disadvantage is overcome.

15 In particular, a filter-tip cigarette is proposed which, through a modification to the structure, economises on material without requiring serious changes to the manufacturing process and to the materials used.

It is a further object of the present invention at least in a preferred form to provide a filter-tip cigarette which negates the need to provide two or more different filter element wrapping materials to the cigarette.

20 The present invention provides a filter cigarette comprising a tobacco rod wrapped in a wrapper and a filter joined thereto, the filter being wrapped along its length in a tipping paper or other wrapper being other than a plugwrap, and a strip of material covering the joint abutment of the tobacco rod and the filter, thus connecting the filter and the tobacco rod, wherein the inherent permeability of the tipping paper or other
25 wrapper is 50-500 CU.

Unless the context clearly requires otherwise, throughout the description and the claims, the words 'comprise', 'comprising', and the like are to be construed in an inclusive sense as opposed to an exclusive or exhaustive sense; that is to say, in the sense of "including, but not limited to".

30 An advantage achieved by the invention is that in the manufacture of the filter no plugwrap is used but, instead, the filter is wrapped with tipping paper or other wrapper immediately on the filter manufacturing machine. The filter rods so manufactured are

2a

sufficiently mechanically stable and can be transported in the conventional manner, for example, pneumatically, to the filter assembler. As used herein below the term 'tipping wrapper' or 'tipping' means tipping wrapper or other wrapper (other than a plugwrap), if not so specified.

5 Bonding or interattaching of the filter to the tobacco rod in the present invention is effected not with tipping but an additional narrower strip of material is used for this which covers the seam between filter and tobacco rod by a few millimetres on both sides.

10 Preferably this strip can likewise consist of the material from which conventional tipping paper is made or may differ from it in design or be of different material, for example, paper which does not have to meet the requirements of tipping paper, or indeed may even be a foil.

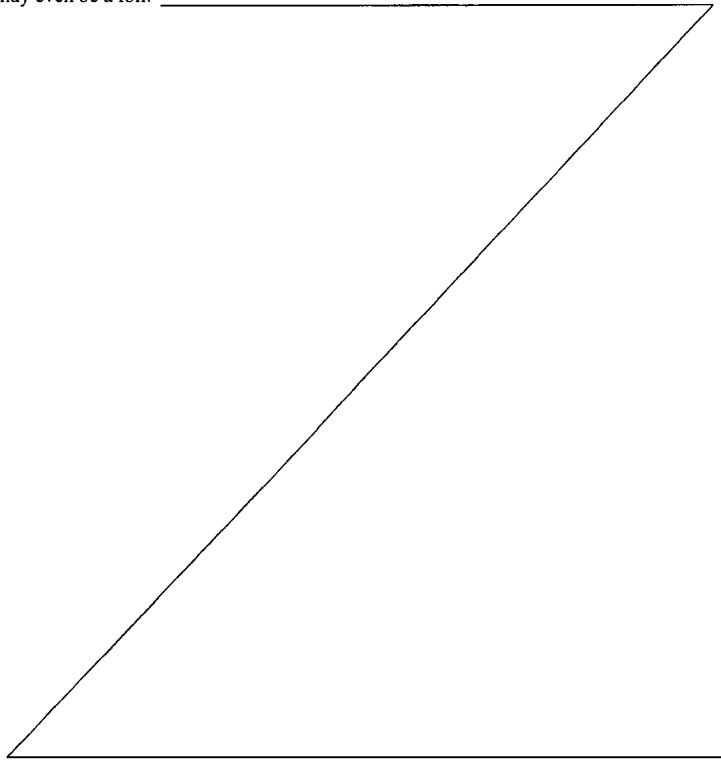

The saving in material which is achieved despite the additional strip of material is a result of the elimination of the plugwrap in conjunction with the reduced width of the relatively expensive tipping paper, which is no longer required to overlap the tobacco rod, i.e. the length of the tipping paper or other wrapper now corresponds to exactly the length of the filter.

This novel filter cigarette can be manufactured on existing cigarette-making machines, in particular existing filter assemblers, where the double width tipping (see Figure 5) can be replaced by two strips of material which are fed at the appropriate distance from one another to the two join locations between the double-length filters and the wrapped tobacco rods (see Figure 6). A very similar process is described in UK Patent Specification No. 1,019,092. No mention is made therein of the removal of plugwrap from the filter element.

The strip of material serving to bond together the filter and the tobacco rod should preferably have a width of from 4 to 12 mm, and more preferably 6 to 10 mm, in order to guarantee an optimal compromise between a stable joint on the one hand and the minimal outlay on material on the other.

For this it is sufficient, in accordance with experience, if the strip of material is a maximum of 20% of the length of the filter, more particularly 15% of the length of the filter, where the degree of overlap of the strip of material is preferably symmetrical for filter and tobacco rod, i.e. the strip of material extends over filter and tobacco rod equally on both sides.

If tipping paper or other wrapper provided with ventilation openings is used then ventilated filter-tip cigarettes can be manufactured in accordance with present day practice. For this it is possible either to use porous tipping paper or other wrapper, or the tipping paper or other wrapper is provided with ventilation openings during or after its manufacture. As an alternative to this it is also possible, in accordance with the practice frequently employed nowadays, to provide the already finished filter-tip cigarette with ventilation openings in the tipping paper or other wrapper, either mechanically or by laser perforation, i.e., for example, the use of pre-perforated tipping paper.

Naturally porous tipping paper or other wrapper is desirable to maintain a consistent level of ventilation. Glue application would only be required on the lap seam of the paper wrapping the filter, with the possibility of a glue 'anchor line' in addition to hold the tipping

paper in place. Reduced usage of glue provides for minimal effect on the air permeability of the paper, giving greater consistency.

An alternative other wrapper is a barrier material which has a pore size of less than about 5 μ m. Preferably the pore size is less than about 1 μ m and even more preferably is less than about 0.1 μ m. Such a material has a high diffusion coefficient (moles/sec/m²) for vapour phases for a given permeability.

Advantageously the barrier means may be formed from a flexible or a rigid material. Advantageously the barrier means may be formed from a vapour porous polymeric material. Preferably the polymeric material may be selected from the group consisting of polyvinylidene fluoride, polyvinyl chloride, polycarbonate, nylon, Teflon™ (PTFE), cellulose acetate or nitrocellulose. Other suitable polymeric materials will be well known to the skilled artisan

The invention has particular application in a number of different embodiments of the invention. The use of particulate materials in the filtration material of filters to reduce vapour phase components of smoke is well known. A more recent concept is the introduction of the particulate material onto a wrapper of the filter element, see, for example, the process described in our co-pending UK Patent Application No. 0310034.4. Most usually the wrapper to which the particulate matter is applied is the plugwrap of the filter element, but in some instances it could be another wrapper. The present invention is of particular usefulness in those instances where a smoking article usually utilises a porous plugwrap, particularly plugwrap having a permeability of >1,500 Coresta Units (CU), preferably >3,000CU, more preferably >10,000 and may be as high as 20,000CU. The application of an adhesive to the porous plugwrap results in bleed-through of the adhesive, which is detrimental to the machinery itself, the process, the final product and its performance. The present invention represents a useful solution to this problem.

Preferably particulate material is applied at a predetermined location on the tipping paper or another wrapper using adhesive, the tipping paper or wrapper being wrapped around the length of the filter element. Preferably the length is the full length of the filter element.

Even more preferably the predetermined location is determined in registration with the position of perforations on a pre-perforated wrapper. The perforations may be circumferentially or longitudinally arranged with respect to the filter. Advantageously the perforations are located upstream of the predetermined location of the particulate material.

Most advantageously the perforations are also located downstream of the strip of material interattaching the filter and tobacco rod.

Preferably the particulate material is one or more of activated charcoal or activated carbon, molecular sieves or other suitable vapour phase absorbents.

5 The inherent permeability of the tipping or other wrapper is preferably greater than 150 CU. The basis weight of the tipping or other wrapper is advantageously within the range of 25-45g/m², and is preferably >30g/m². When the tipping is perforated advantageously the level of ventilation is between 50-5,000 CU/cm length in the area of perforation.

10 The basis weight of the strip of material is advantageously in the range of 20-50 g/m².

A further advantage that the present invention provides is a solution with respect to the joining of elements of a smoking article that may not be conventional. For example, the wrapper described in our pending International Patent Application, 15 Publication No. WO 01/41590 is comprised of a particulate ceramic filler of predefined shape and a binder (either inorganic or organic), with optional ash improver and/or burn additive. The ceramic filler may be present in the range of 50-95% by weight of the wrapper and advantageously has a particle size in the range of 2-90 µm, and preferably a mean particle size of about 50 µm. Preferably the filler is alumina or another similar 20 thermally stable metal oxide or metal salt. In view of the more fragile nature of such a wrapper it may be advantageous to interattach the tobacco rod enclosed in this wrapper to a filter by a method that does not require rolling of the whole wrapped tobacco rod on a rolling plate as in conventional methods of interattaching a tobacco rod and filter. There is thus provided a filter tip cigarette with a non-conventional wrapper attached to a 25 filter without plugwrap using a narrow strip of material.

The present invention provides a method of producing filter tip cigarettes comprising a filter wrapped in a tipping paper or other wrapper being other than plugwrap, wherein the inherent permeability of the tipping paper or other wrapper is 50-500 CU, and a tobacco rod wrapped in a wrapper, the tipping paper or other wrapper of 30 the filter having particulate material attached thereto, the method comprising the steps of supplying filter tow to a filter making machine, supplying the tipping paper or other wrapper to a particulate material applying station located at the filter making machine, at

which station particulate material is attached to the tipping or other wrapper, wrapping the filter tow with the treated wrapper and cutting the wrapped filter tow into unit filter lengths, thereafter supplying the cut lengths to a filter tip assembly machine wherein said filter tip assembly machine utilises a narrow strip of material to interattach said filter to said tobacco rod to produce filter tip cigarettes.

The method preferably comprises supplying inherently porous or perforated tipping or other wrapper to the filter making machine.

A further use of the invention may be in factories producing low volumes of various filter tipped products. Often there is a need to supply filter elements having different filter ventilation levels to different making machines. The present invention would enable a filter manufacturer to produce filters wrapped in a wrapper other than plugwrap (as outlined above). The wrapper may be pre-perforated or the wrapped filter element can be perforated online. Successive batches of filters can thus be produced to different ventilation levels, then supplied to a succession of cigarette making machines using strips of material for interattaching a tobacco rod and filter elements, each machine requiring filters of a particular ventilation level. There are thus advantages in cost savings by negating the use of plugwrap and an increase in filter machinery productivity.

The present invention provides a method of reducing filter-tip cigarette manufacturing cost, the method comprising providing batches of filters wrapped along their length in a tipping paper or other wrapper being other than plugwrap, wherein the inherent permeability of the tipping paper or other wrapper is 50-500 CU, and each batch of wrapped filters having a predetermined ventilation level and being sourced from the same filter making machine, and supplying the batches of ventilated wrapped filters to respective filter tip assembly machines capable of producing a double cigarette assembly of a double filter between two wrapped tobacco rods, each filter tip assembly machine utilising two narrow strips of material to interattach the double filter and two wrapped tobacco rods, cutting the double filter to provide two filter tip cigarettes, and thereby producing batches of differently ventilated filter tip cigarettes from a plurality of filter tip assembly machines.

A further use is in the prevention of hot coal fallout which occurs as the cigarette burns down towards the filter and the tipping paper. The strip of material may be treated with material designed to help prevent hot coal fall out as the cigarette burns down to the

6a

finish, for example material designed to cause extinction of the cigarette, or
alternatively, the strip of material may be a heavy weight, low permeability paper that
causes a reduction in burn rate and hence extinguishment of the cigarette. Typical paper
characteristics of such a wrapper are an inherent permeability of 3 CU or less, preferably
5 2 CU or less, more preferably 1 CU or less, and a basis weight of in a range of 40-
45g/m². Suitable treatments include the use of burn retardants, such as those known to
the man skilled in the art, for example, monoammonium phosphate.

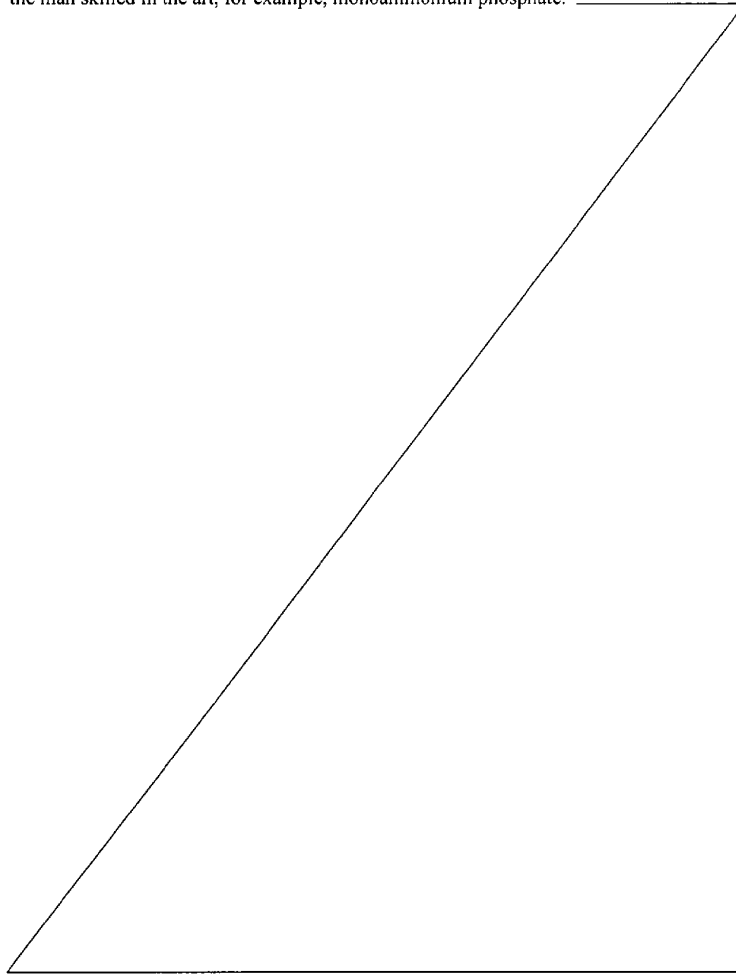

The strip of material may alternatively be treated with thermochromic material that will undergo a colour change to reveal a message or an indicia as temperature increases. A further alternative is the printing or sticking on of promotional material thereupon.

Advantageously the strip of material is self adhesive, which eliminates the problems that can be caused with glue applicators on filter tipping machines.

The invention is described in more detail by means of examples with reference to the attached schematic drawings in which:

Figure 1 is a cross-section transverse to the longitudinal axis of a filter of a cigarette in accordance with the state of the art,

Figure 2 is a cross-section transverse to the longitudinal axis of a filter of a cigarette in accordance with the invention,

Figure 3 is a longitudinal cross-section of a filter-tip cigarette using the filter of Figure 1 in accordance with the state of the art,

Figure 4 is a view corresponding to Figure 3 of a filter-tip cigarette in accordance with the invention,

Figure 5 is a schematic view of a 'double cigarette' joined through a double filter in accordance with the state of the art,

Figure 6 is a view corresponding to Figure 5 of a 'double cigarette' in accordance with the invention, and

Figure 7 is a longitudinal cross section of a further embodiment of the filter tip cigarette of the invention.

The conventional filter-tip cigarette represented in Figures 1, 3 and 5 has already been described in detail above. These Figures are contrasted with the filter-tip cigarettes in accordance with the invention in Figures 2, 4 and 6.

As can be seen in Figures 2 and 4, the filter-tip cigarette in accordance with the invention consists of a tobacco rod 1' wrapped in cigarette paper and a filter 6' with a filtration material 2' and with a wrapper 4' of tipping paper. The tipping paper 4' extends over the entire length of the filter 6', but not beyond it, and thus also wraps the whole circumference of the filtration material 2'. A strip of material 5 covers the joint abutment between the tobacco rod 1' and the filter 6', as is clear from Figure 4, and also extends slightly over the outer circumference of the tobacco rod 1' and filter 6', and serves to bond together the tobacco rod 1' wrapped in cigarette paper with the filtration material 2' wrapped

in tipping paper 4' and hence with the filter 6'. The strip of material 5 should have a width of 4 to 12 mm, more particularly 6 to 10 mm. Good results have been achieved with a width of about 8 mm.

This approximates to the requirement that the strip of material 5 overlap by a maximum of 20%, more particularly less than 15% of the length of the filter 6'. As can be further seen from Figure 4, the degree of overlap of the strip of material 5 is symmetrical for filter 6' and tobacco rod 1', i.e. the strip of material 5 covers the same area on both sides over the filter 6' and the tobacco rod 1'.

Although not illustrated in Figures 2, 4 and 6, the tipping paper 4' can be porous or provided with ventilation openings in order to enable ventilation of the cigarette.

As an alternative it is also possible to provide finished filter-tip cigarettes already provided with filters with ventilation openings, either mechanically or by laser perforation.

As the material for the strip 5 it is possible to employ all of the materials used in cigarette manufacture, such as tipping paper, other papers, such as, for example cigarette paper, foil, etc. The strip of material 5 may be printed or unprinted. The strip of material may also be treated with material designed to help prevent hot coal fall out as the cigarette burns down to the finish.

It is also not necessary to make any changes to the filtration material, that is, all conventional filtration materials, such as cellulose acetate, paper or tobacco, with or without additives such as activated charcoal, additives, etc., can be considered.

As can be seen from Figure 6 filter-tip cigarettes in accordance with the invention may be manufactured essentially by the same process as is shown in Figure 5, namely with a double filter 6', to the ends of which two tobacco rods 1' are attached by means of two strips of material 5. The double filter is then divided in the middle to produce two filter-tip cigarettes of filters 6' and tobacco rods 1'.

Figure 7 shows a filter tip cigarette in accordance with the invention in which the tipping 4' has been treated with adhesive at a predetermined location 7 and then a particulate material has been adhered thereto before wrapping around the filtration material of filter 6'. Upstream of each location 7 of particulate material are ventilation perforations 8 which in this instance were present in the tipping before the tipping was wrapped around the filtration material. The perforations may be produced after application of the particulate material, but most preferably before application of particulate material. The location of the particulate

material is in register with the perforations, and in registration with the strips of material 5. The strips of material 5 join each tobacco rod with the respective ends of the double filter.

THE CLAIMS DEFINING THE INVENTION ARE AS FOLLOWS:-

1. A filter cigarette comprising a tobacco rod wrapped in a wrapper and a filter joined thereto, the filter being wrapped along the length thereof in a tipping paper or other wrapper being other than a plugwrap, and a strip of material covering the joint
5 abutment of the tobacco rod and the filter, thus connecting the filter and tobacco rod, wherein the inherent permeability of the tipping paper or other wrapper is 50-500 CU.
2. A filter cigarette according to Claim 1, wherein the strip of material is tipping paper.
3. A filter cigarette according to Claim 1, wherein the strip of material is a foil
10 material.
4. A filter cigarette according to Claims 1, 2 or 3, wherein the strip of material is printed or imprinted.
5. A filter cigarette according to one of Claims 1 to 4, wherein the strip of material has a width of 4 to 12 mm.
- 15 6. A filter cigarette according to Claim 5, wherein the strip of material has a width of 6 to 10 mm.
7. A filter cigarette according to one of the preceding claims, wherein the strip of material extends over a maximum of 20% of the length of filter.
8. A filter cigarette according to Claim 7, wherein the strip of material extends over
20 less than 15% of the length of filter.
9. A filter cigarette according to one of Claims 1 to 8, wherein the degree of coverage of the strip of material interattaching the filter and tobacco rod is equal.
10. A filter cigarette according to one of Claims 1 to 9, wherein the tipping paper or other wrapper contains ventilation holes.
- 25 11. A filter cigarette according to any one of the preceding claims, wherein the basis weight of the tipping or other wrapper is 25-45 g/m².
12. A filter cigarette according to any one of Claims 1 to 9, wherein said other wrapper is a barrier material which has a pore size of less than about 5 μ m.

13. A filter cigarette according to Claim 12, wherein said barrier material has a pore size of less than about 1 μm .
14. A filter cigarette according to Claim 12 or Claim 13, wherein said barrier material is formed from a vapour porous polymeric material.
- 5 15. A filter cigarette according to any one of the preceding claims, wherein a particulate material is applied at a predetermined location on said tipping paper or other wrapper.
16. A filter cigarette according to Claim 15, wherein said particulate material is one or more of activated charcoal, activated carbon and molecular sieves.
- 10 17. A filter cigarette according to any one of the preceding claims, wherein, when the tipping paper or other wrapper is perforated, the level of ventilation is between 50 and 5,000 CU/cm length in the area of the perforation.
18. A filter cigarette according to any one of the preceding claims, wherein the basis weight of the strip of material is in the range of 20-50 g/m^2 .
- 15 19. A filter cigarette according to any one of the preceding claims, wherein the tobacco rod wrapper is a wrapper comprising a particulate ceramic filler of predefined shape and a binder, with optional ash improver and/or burn additive.
20. A filter cigarette according to Claim 19, wherein the ceramic filler is present in the range of 50-95% by weight of the wrapper.
- 20 21. A filter cigarette according to Claim 19 or 20, wherein the ceramic filler has a particle size in the range of 2-90 μm .
22. A filter cigarette according to Claim 21, wherein the ceramic filler has a mean particle size of about 50 μm .
23. A filter cigarette according to any one of Claims 19, 20, 21 or 22, wherein the ceramic filler is alumina or another similar thermally stable metal oxide or metal salt.
- 25 24. A method of reducing filter-tip cigarette manufacturing cost, the method comprising providing batches of filters wrapped along their length in a tipping paper or other wrapper being other than plugwrap, wherein the inherent permeability of the tipping wrapper is 50-500 CU, and each batch of wrapped filters having a predetermined
- 30 ventilation level and being sourced from the same filter making machine, and supplying

the batches of ventilated wrapped filters to respective filter tip assembly machines capable of producing a double cigarette assembly of a double filter between two wrapped tobacco rods, each filter tip assembly machine utilising two narrow strips of material to interattach the double filter and two wrapped tobacco rods, cutting the double
5 filter to provide two filter tip cigarettes, and thereby producing batches of differently ventilated filter tip cigarettes from a plurality of filter tip assembly machines.

25. A method of producing filter tip cigarettes comprising a filter wrapped in a tipping paper or other wrapper being other than plugwrap, wherein the inherent permeability of the tipping paper or other wrapper is 50-500 CU, and a tobacco rod
10 wrapped in a wrapper, the tipping paper or other wrapper of the filter having particulate material attached thereto, the method comprising the steps of supplying filter tow to a filter making machine, supplying the tipping paper or other wrapper to a particulate material applying station located at the filter making machine, at which station
15 particulate material is attached to the tipping or other wrapper, wrapping the filter tow with the treated wrapper and cutting the wrapped filter tow into unit filter lengths, thereafter supplying the cut lengths to a filter tip assembly machine wherein said filter tip assembly machine utilises a narrow strip of material to interattach said filter to said tobacco rod to produce filter tip cigarettes.

26 A method according to Claims 24 or 25, wherein said tipping paper or other
20 wrapper is provided with ventilation holes either during or after manufacture.

27. A method according to Claims 24 or 25, wherein the filter cigarette is provided with ventilation holes in the tipping paper or other wrapper.

28. A method according to any one of Claims 24-27, wherein the ventilation holes are produced mechanically or by laser means.

25 29. A filter cigarette substantially as herein described with reference to any one of the embodiments of the invention illustrated in the accompanying drawings and/or examples.

30. A method of reducing filter-tip cigarette manufacturing costs substantially as herein described with reference to any one of the embodiments of the invention
30 illustrated in the accompanying drawings and/or examples.

2003249076 10 Jan 2007

13

31. A method of producing filter-tip cigarettes substantially as herein described with reference to any one of the embodiments of the invention illustrated in the accompanying drawings and/or examples.

Fig.1.

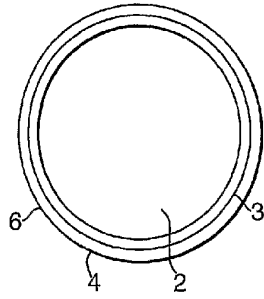

Fig.2.

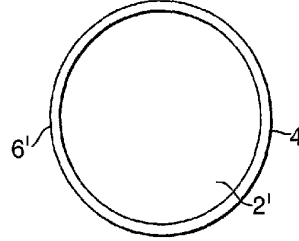

Fig.3.

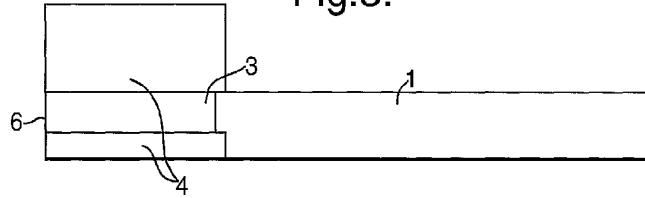
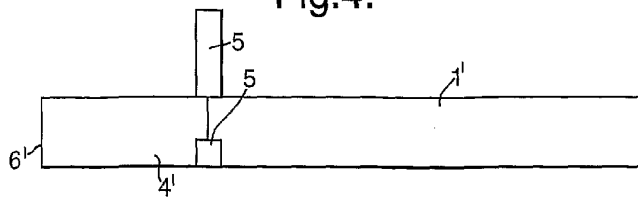
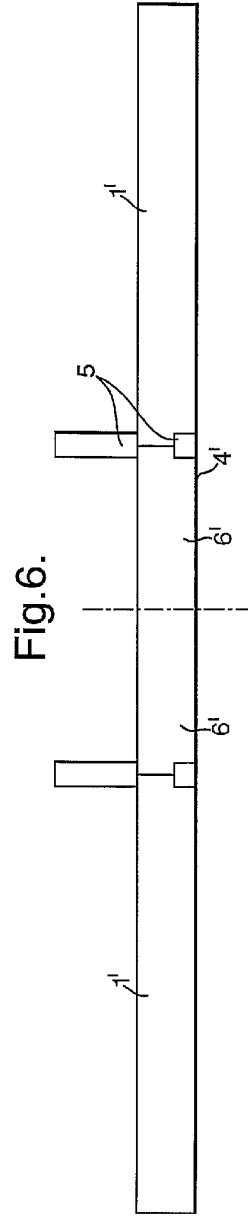
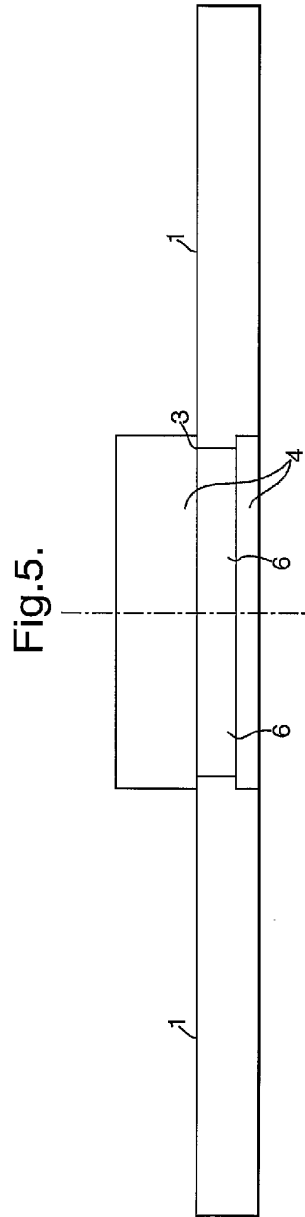

Fig.4.



SUBSTITUTE SHEET (RULE 26)



SUBSTITUTE SHEET (RULE 26)

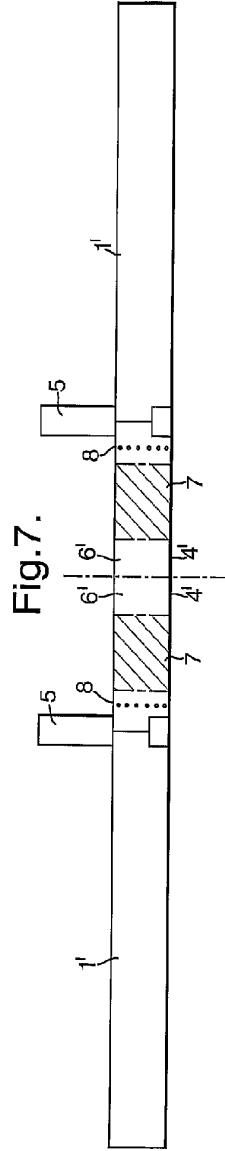

SUBSTITUTE SHEET (RULE 26)