

H. HOLLERITH.
 TABULATING APPARATUS.
 APPLICATION FILED FEB. 14, 1906.

998,095.

Patented July 18, 1911

3 SHEETS—SHEET 1

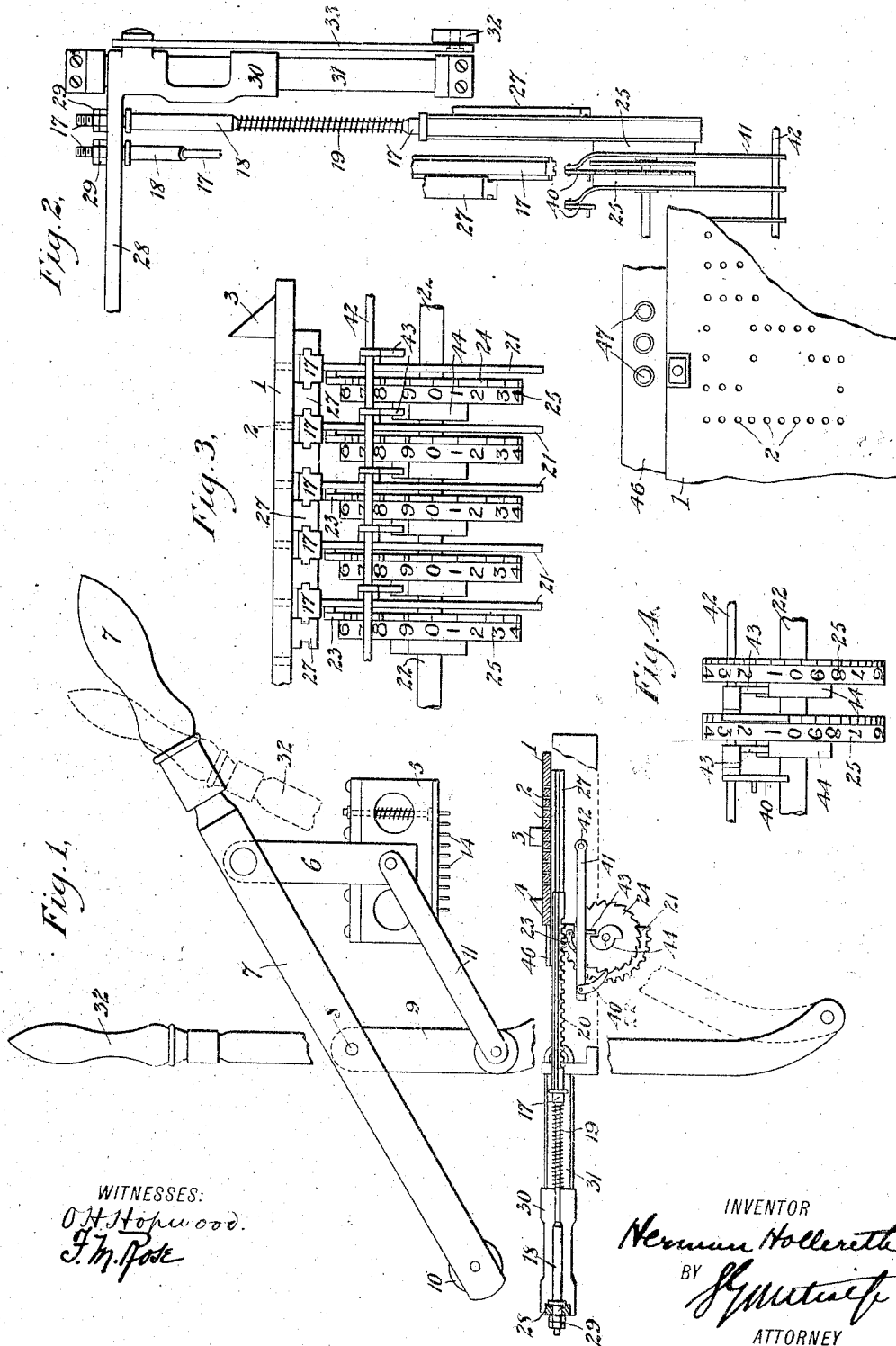

WITNESSES:
O. H. Hopwood.
J. M. Rose

INVENTOR
Herman Hollerith
 BY *J. M. Rose*
 ATTORNEY

H. HOLLERITH.
 TABULATING APPARATUS.
 APPLICATION FILED FEB. 14, 1906.

998,095.

Patented July 18, 1911.
 3 SHEETS—SHEET 2.

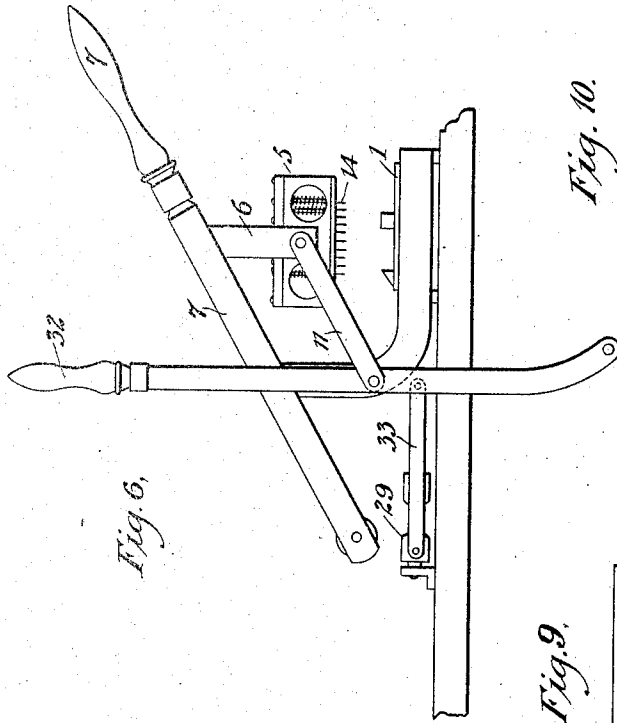

Fig. 6.

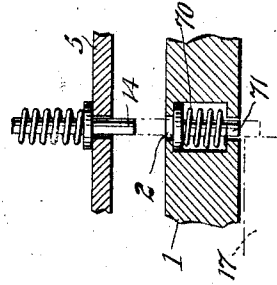

Fig. 10.

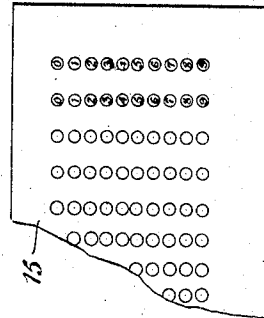

Fig. 9.

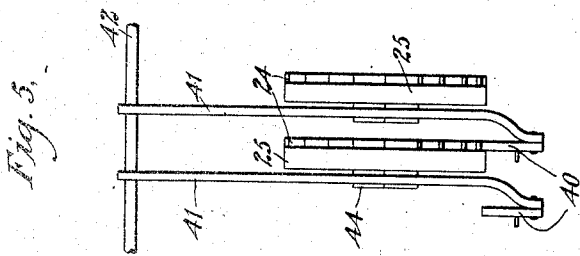

Fig. 5.

WITNESSES:
O. H. Stopwood,
J. M. Hall

INVENTOR
Herman Hollerith
 BY *J. M. Hall*
 ATTORNEY

H. HOLLERITH.
 TABULATING APPARATUS.
 APPLICATION FILED FEB. 14, 1906.

998,095.

Patented July 18, 1911.

3 SHEETS-SHEET 3.

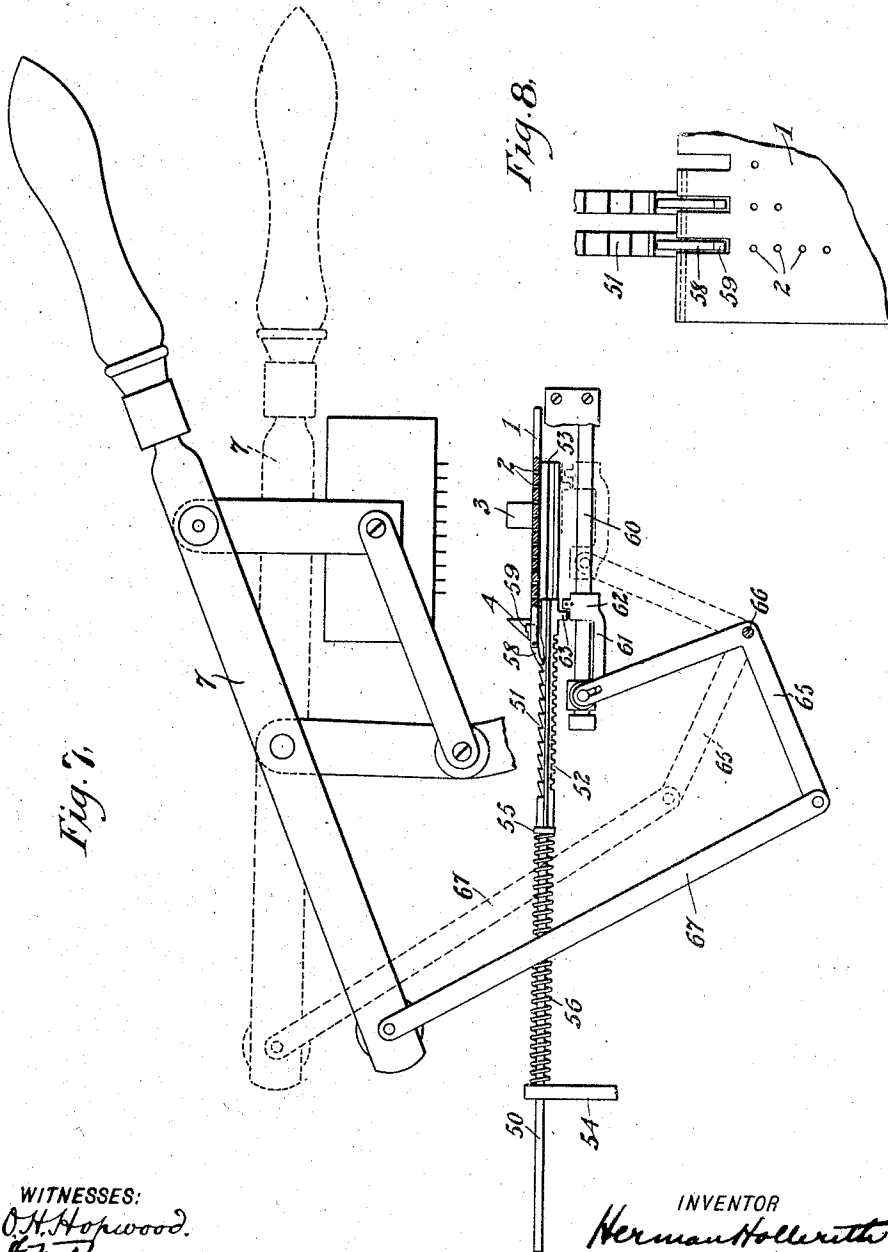

WITNESSES:
O. H. Hopwood.
J. M. Fox.

INVENTOR
Herman Hollerith
 BY *J. M. Fox*
 ATTORNEY

UNITED STATES PATENT OFFICE.

HERMAN HOLLERITH, OF GARRETT PARK, MARYLAND, ASSIGNOR TO THE TABULATING MACHINE COMPANY, A CORPORATION OF NEW JERSEY.

TABULATING APPARATUS.

998,095.

Specification of Letters Patent. Patented July 18, 1911.

Application filed February 14, 1906. Serial No. 301,092.

To all whom it may concern:

Be it known that I, HERMAN HOLLERITH, a citizen of the United States, and a resident of Garrett Park, Montgomery county, Maryland, have invented certain new and useful Improvements in Tabulating Apparatus, of which the following is a full, clear, and exact description, reference being had to the accompanying drawings, forming part of this specification.

My present invention relates to apparatus for use in the Hollerith tabulating system in which the data or items to be tabulated are denoted by index points formed upon a record usually in the form of a card, the index points being formed by punching holes in the record at predetermined points. The apparatus herein described and claimed is intended primarily for operation in connection with such records in which the value or amount of the items is determined by the location of the index points in rows, each row having index-point positions from 0 to 9 in value or amount, and for the purpose of clearly describing the invention, I have selected a preferred form of apparatus embodying a series of registering elements or wheels of different orders or denominations upon which any item of amount or value will be registered upon the wheels by one operation of the apparatus, which is thus distinguished from apparatus intended only for the addition of units.

My present invention provides for the mechanical operation of the apparatus as distinguished from other forms of apparatus in which, for example, electrically or pneumatically operated devices are controlled or actuated by means of the index points of the record, but subject to this provision I do not intend that my invention shall be limited to the specific devices which I have illustrated and described for effecting such mechanical operation of the apparatus, many of which may be departed from without any departure from the broad principles of my present invention.

In the accompanying drawings which represent a preferred form of apparatus embodying my invention, Figure 1 represents an elevation partly in section; Fig. 2 is a partial plan view; Fig. 3 is a front elevation of the registering mechanism; Figs. 4

and 5 are respectively a rear elevation and a top plan view of a portion of the registering mechanism designed to show particularly the transfer or carrying devices; Fig. 6 is an end elevation of the machine, designed particularly to show those portions of the mechanism not clearly shown in the elevation represented in Fig. 1; Fig. 7 is a sectional elevation of a modified form of machine; Fig. 8 is a plan view of a detail of the machine shown in Fig. 7; Fig. 9 is a partial plan view of one of the records or cards, and Fig. 10 is a detail view showing a modification.

Similar letters of reference are employed to designate like parts.

Referring particularly to the machine shown in Figs. 1 to 6 inclusive, 1 represents the bed plate or support for the record cards, the same being provided with perforations or holes 2 and with stops 3 and 4, the former located at the right hand end and the latter at the rear side of the bed plate, for the purpose of insuring the proper positioning or centering of the record card. A movable pin box or platen 5 is suspended by a link 6 from a hand lever 7 that is pivoted at 8 to a rigid standard 9 and has a counterweight 10 secured to its rear end to normally hold the outer end of said hand lever and consequently the suspended pin box or platen in an elevated position. An arm 11 extending parallel to the hand lever is jointed at one end to the pin box and at the other to the rigid standard 9 and serves to steady the pin box during its upward and downward movements. The pin box is provided with transverse rows of spring pressed pins 14, corresponding in number and relative arrangement to the perforations in the bed plate 1. There are preferably ten pins in each row having a value of from 0 to 9, as represented in Fig. 1.

A record card 15, such as I preferably use is partially shown in Fig. 9. Upon its surface are marked or printed a series of transverse rows of index-point positions corresponding in number and relative position to the series of rows of holes or perforations in the bed plate, each row like those of the bed plate comprising index-point positions from 0 to 9 in value. In the preparation of the card it is intended that an index-point

shall be punched out in each of the rows marked upon it so that when the card is placed upon the bed plate of the machine with its edges against the stops 3 and 4, all of the holes punched in the several rows will coincide or register with the corresponding holes or perforations in the bed plate, and when the pin box or platen is brought down upon the card one of the spring pins in each row will pass through said card and also through the corresponding hole in the bed plate and project below the lower face of the latter, while all the rest of the spring pins will come in contact with the imperforate portions of the card and will be forced back within the pin box, and thus rendered inoperative so far as that card is concerned.

Below the bed plate and at one side thereof are arranged a series of what may be termed register-actuators, consisting as shown in Fig. 1, of movable telescopic bars, each composed of two sections, a bar 17 and a sleeve 18, held normally extended by an interposed spring 19. These register actuators are as many in number as there are series of pins in the pin box, that is to say, there is a register actuator for each transverse row of pins. Upon each bar 17 is formed or attached a rack 20 which meshes with the teeth of a movable sector 21 hung so as to turn freely upon a shaft 22 and carrying a pawl 23 which is adapted to engage the teeth of a ratchet wheel, such as 24, secured to or made integral with a registering or counting wheel 25 adapted to carry upon its periphery two series of figures from 0 to 9. The forward end of each bar 17 is guided by suitable guides 27, arranged beneath the bed plate as shown in Figs. 1 and 3, while its rear end slides telescopically in the sleeve 18 which is supported by a cross bar 28, its extremity being screw threaded to receive nuts 29 as shown in Figs. 1 and 2. The cross bar 28 extends from side to side of the machine and its ends are formed into slides 30 which are adapted to move back and forth on ways 31, (Figs. 1 and 2). A hand lever 32 is connected to the slides 30 of the cross bar by means of links 33.

The operation is as follows: When the perforated record card is placed in proper position upon the bed plate of the machine, and the pin box or platen is brought down upon it, one pin of each row in the pin box will pass down through the card and through the corresponding perforations in the bed plate into the path of the movable bars 17. All the bars 17 are then simultaneously advanced by pulling forward the lever 32 and each bar 17 is advanced until intercepted by the pin projecting in its pathway, the amount of its forward motion being proportional to the location of the pin which is determined by the value of the hole punched in the given row or column in the card. It will

happen, of course, that some of the bars 17 will be arrested sooner than others, but this does not prevent the others from continuing their forward movement until their respective pins are reached as the only effect of arresting a bar before the limit of movement of the cross-bar 28 is reached is to cause it to telescope with its sleeve 18 and compress the spring 19. The forward movement of each bar 17 of course causes the gear section 21 in coöperation with it to turn forward and its pawl 23 to slip over the teeth of the ratchet wheel 24, the number of teeth passed over being determined by the extent of the movement of the bar 17. As the handle 32 is moved back, the spring 19 forces backward the cross bar 28 until said bar comes up against the nuts 29 on the ends of the bars 17, when the continued movement of the cross bar carries backward the bars 17, causes the rack teeth thereon to turn the gear sectors 21 and the pawls 23 on the gear sectors to turn the ratchet wheels 24, together with the registering wheels 25, more or less, according to the amount of motion imparted to the bars 17 respectively.

It will be observed, that as each card is placed in the machine and operated upon, the gear segments are reciprocated back and forth, while the ratchet wheels and their attached numbered or registering wheels move only forward, the extent of motion being dependent upon the value of the punched holes in the card.

The transfer mechanism which I employ to perform the transfer or carry from one registering wheel to the wheel of next higher order as the wheel of lower order passes from 9 to 0, comprises a pawl 40 for each registering wheel above the unit wheel mounted upon a carry lever 41, that is pivoted upon a rod 42 and that has a projection 43 which rests upon a double cam 44 carried by the ratchet wheel 24 or 16 what is the same in effect, the connected registering wheels of next lower value. Each time a registering wheel of lower value moves from 9 to 0, one of the cam surfaces of the double cam 44 will engage the projection 43, raise the carry lever 41 until the pawl 40 makes engagement with the next tooth of the ratchet wheel connected with the registering wheel of next higher denomination and will then release said carry lever and the latter in falling, will, through its pawl 40, cause the registering wheel of higher denomination to be advanced one point. I have illustrated in the drawings, a double cam for the reason that the registering wheels shown are intended to bear two series of numbers from 0 to 9.

In order that the numbers on the registering wheels may be read with convenience, I arrange above the registering wheels, at the rear end of the bed plate, a plate 46, having

openings 47, through which the numbers on the registering wheels below may be plainly seen.

5 Instead of employing divided or telescopic register actuators and two hand levers, one for operating the pin box and the other for operating the register actuators as in the machine hereinbefore described, I may employ spring-pressed, non-
10 telescopic register actuators held normally in check by pawls and that are released upon the descent of the pin box or platen, and I may arrange such connections between the pin box and the said register actuators that
15 only a single hand lever may be required to perform all the necessary operations. Such a modification of the invention is illustrated in Figs. 7 and 8 which show the pin box or platen 5 provided with the spring pins 14
20 and the perforated bed plate 2. Below the bed plate are arranged a series of bars 50 whose forward ends have ratchet teeth 51 on the upper side and rack teeth 52 on the under side. The forward end of each of
25 these bars is suitably guided in guides 53 while its rear end passes through a fixed guide 54. Between a collar 55 upon each of these bars, and the fixed guide 54 is arranged a spring 56 whose tendency is to
30 force the bar forward. Pivoted to one side of the bed plate is a series of pawls 58, there being one for each bar. The rear end of each of these pawls is adapted to engage with the ratchet teeth on its cooperating bar,
35 while its upper or forward end 59 projects within the path of the pin box so that it will be struck when the pin box is depressed. Beneath the bed plate at opposite ends of the machine are arranged guides 60 upon
40 which are adapted to travel slides 61 that are connected by a cross bar 62 shown in dotted lines (Fig. 7), extending from end to end of the machine and in the path of projections 63 depending from the movable
45 bars. Jointed to the slides 61 are bell crank levers 65 pivoted at 66 and having their lower members connected by bars 67 to the hand lever of operating handle 7. The rack teeth of the bars are adapted to engage with the gear segments forming part of the hereinbefore described registering mechanism.
50 The operation of this form of machine is as follows: When a perforated record card is placed upon the bed plate and the pin box is brought down by the operation of the hand lever, the slides 61 and cross bar 62 are moved forward to the front of the machine as shown in dotted lines, (Fig. 7).
55 After the appropriate pins of the pin box have passed through the holes in the record card and through the holes in the bed plate, so that they project below the lower surface of the bed plate, the pin box continues its downward movement until it strikes the
60 projections 59 of the pawl 58 and releases

all of them from their respective bars, the latter then, under the influence of their springs advancing a greater or less distance, according to the position of the particular pin in the path of each, until arrested by
70 said pins. When now the hand lever is raised, the slides 61 and cross bar 62 move backward, the cross bar engaging the projections 63 on the actuating bars one after another and carrying the bars back to their
75 initial positions, this backward movement of the bars causing an advance of the registering mechanism connected to each, proportioned to the distance each bar travels, as will be readily understood. The effect of
80 thus carrying the bars back to initial position is to again compress their operating springs and reengage them with their retaining pawls. As will be seen by inspection of Fig. 7, the first tooth of each actuator bar is made shorter than the succeeding
85 teeth so that when the first pin (standing for 0) of the row of pins in the pin box comes down through the corresponding first hole in the bed plate, the bar that is to engage it will, when released by the operation
90 of the pawl, move forward only the length of the short tooth or so as to bring the second ratchet tooth in position to be engaged by the pawl when the pin box is raised
95 again, this amount of movement being, however, insufficient to cause the pawl 23 (Fig. 1) carried by the gear sector 21 to engage the next succeeding tooth of the ratchet wheel 24, the result being that when the
100 actuator bar is moved back to its initial position by the backward motion of the cross bar 62, the said pawl 23 will make a dead stroke and no change of position of the registering wheels will take place.

105 In the apparatus above described, the pins 14 act as stops to determine the operative movement of the actuators; but as will be understood, it is not essential that the pins 14 should directly engage the actuating bars
110 17 or arrest their movement, since intermediate devices, actuated mechanically by the pins, may be provided to determine the extent of movement imparted to the registering elements or wheels by the actuating bars
115 or actuators at each operation. I have shown on an enlarged scale in Fig. 10 a construction in which such intermediate devices are employed. In this instance, they serve to arrest the movement of the actuators. In
120 the modification shown the holes in the bed plate are enlarged and in each of them is supported, by a coil spring 70, a plunger 71. When the pin box is depressed, the pins 14 will engage such of the plungers 71 as lie
125 under the perforations in the second card, and will press down the plungers into the path of the actuator bars, so that when the latter are advanced they will engage the plungers and their movement will be ar-
130

rested as indicated in dotted lines. When the pin box is raised and the actuator bars moved out of engagement with the plungers the plungers will be lifted by their springs out of the path of movement of the actuator bars. This figure of the drawings is only illustrative of one means by which the result may be accomplished.

The apparatus herein illustrated is susceptible of wide variation so long as the pins act mechanically to determine the extent of movement imparted to the registering elements at each operation.

Having thus shown and described my invention, what I claim as new, and desire to secure by Letters Patent, is:

1. In a tabulating apparatus the combination with a perforated record card, of register wheels, actuators therefor, and stops mechanically controlled by the record card for determining the amount of movement imparted by the actuators.

2. In a tabulating apparatus the combination with a perforated record card, of a series of independently movable register wheels, an actuator for each of said register wheels, a series of stops for each actuator, each of said stops being mechanically controlled by the record card in accordance with the location of an index point thereon, means for moving said actuators to engage said stops and means for restoring the actuators to normal position.

3. In a tabulating apparatus the combination with a perforated record card of register wheels, actuators therefor, stops mechanically controlled by the record card for determining the amount of movement of the actuators and transfer mechanism for the register wheels.

4. In a tabulating apparatus the combination with a perforated record card, of a series of independently movable register wheels, an actuator for each of said register wheels, a series of stops for each actuator each of said stops being mechanically controlled by the record card in accordance with the location of an index point thereon means for moving said actuators to engage said stops, means for restoring the actuators to normal position and transfer mechanism for the register wheels.

5. In a tabulating apparatus the combination with a perforated record card, of reg-

ister wheels, actuators therefor and stops actuated through the record card for controlling the movement of the actuators.

6. In a tabulating apparatus, the combination with a record card, of register wheels, actuators for moving the register wheels, means, free from the control of the record card for moving the actuators and pins controlled by the record card for determining the extent of movement imparted to the register wheels by the actuators at each operation.

7. In tabulating apparatus, the combination with a record card having index points formed by punched holes, of registering elements, adapted to be operated according to the location of the index points, actuating devices therefor, means free from the control of the record card for moving the actuating devices and pins controlled by the record, according to the location of the index points, for engaging the actuating devices to determine the movement of the tabulating devices.

8. In tabulating apparatus the combination with a record card having index points formed by punched holes, of registering elements adapted to be operated according to the location of the index points, and pins, controlled by the record card according to the location of the index points, acting mechanically to control the operation of said registering elements.

9. In a device of the character described, the combination of a perforated record card, registering devices, transfer mechanism, actuators for the registering devices and stops mechanically controlled by the record card and acting mechanically to determine the amount of movement of the actuators.

10. In a device of the character described, the combination of a record card having index points formed by punched holes, registering elements adapted to be operated according to the location of the index points, transfer mechanism, and pins controlled by the record card according to the location of the index points, acting mechanically to control the operation of said registering elements.

HERMAN HOLLERITH.

Witnesses:

OTTO E. BRAITMAYER,
PERCY F. SMITH.