



US00D474434S

(12) **United States Design Patent**
Pfeiffer et al.

(10) **Patent No.:** **US D474,434 S**

(45) **Date of Patent:** **** May 13, 2003**

(54) **SURFACE CONFIGURATION OF A CONTROL PANEL FOR A VEHICLE**

(75) Inventors: **Peter Pfeiffer**, Boeblingen (DE); **Murat Guenak**, Ehningen (DE); **Franz Lecher**, Sindelfingen (DE); **Steffen Koehl**, Stuttgart (DE)

(73) Assignee: **DaimlerChrysler AG**, Stuttgart (DE)

(**) Term: **14 Years**

(21) Appl. No.: **29/164,618**

(22) Filed: **Jul. 29, 2002**

(30) **Foreign Application Priority Data**

Jan. 28, 2002 (DE) 4 02 00 677

(51) **LOC (7) Cl.** **12-16**

(52) **U.S. Cl.** **D12/192**

(58) **Field of Search** D12/192, 415; 280/770, 750-752, DIG. 5; 296/70-72, 190-191, 37.1-37.8; D10/49-51, 103; D23/327, 354, 387, 324; D14/157, 427; 180/90; D15/28

(56) **References Cited**

U.S. PATENT DOCUMENTS

D195,783 S * 7/1963 Woods D12/192

D318,255 S * 7/1991 Maxwell D12/192
D372,010 S * 7/1996 Pfeiffer et al. D12/192
D394,017 S * 5/1998 Liao et al. D12/192 X
D394,626 S * 5/1998 Sacco et al. D12/192
D401,545 S * 11/1998 Sacco et al. D12/192
D437,575 S * 2/2001 Tamashima et al. D12/192
D440,927 S * 4/2001 Pfeiffer D12/192
D449,026 S * 10/2001 Tsay et al. D12/192

* cited by examiner

Primary Examiner—Stacia Cadmus

(74) *Attorney, Agent, or Firm*—Crowell & Moring LLP

(57) **CLAIM**

The ornamental design for a surface configuration of a control panel for a vehicle, as shown and described.

DESCRIPTION

FIG. 1 is a front view of a surface configuration of a control panel for a vehicle according to our novel design; and, FIG. 2 is a left perspective view of the surface configuration of a control panel for a vehicle according to our novel design, the right perspective view being mirror symmetrical. The dash lines included depict environment and are not part of the claimed design.

1 Claim, 1 Drawing Sheet

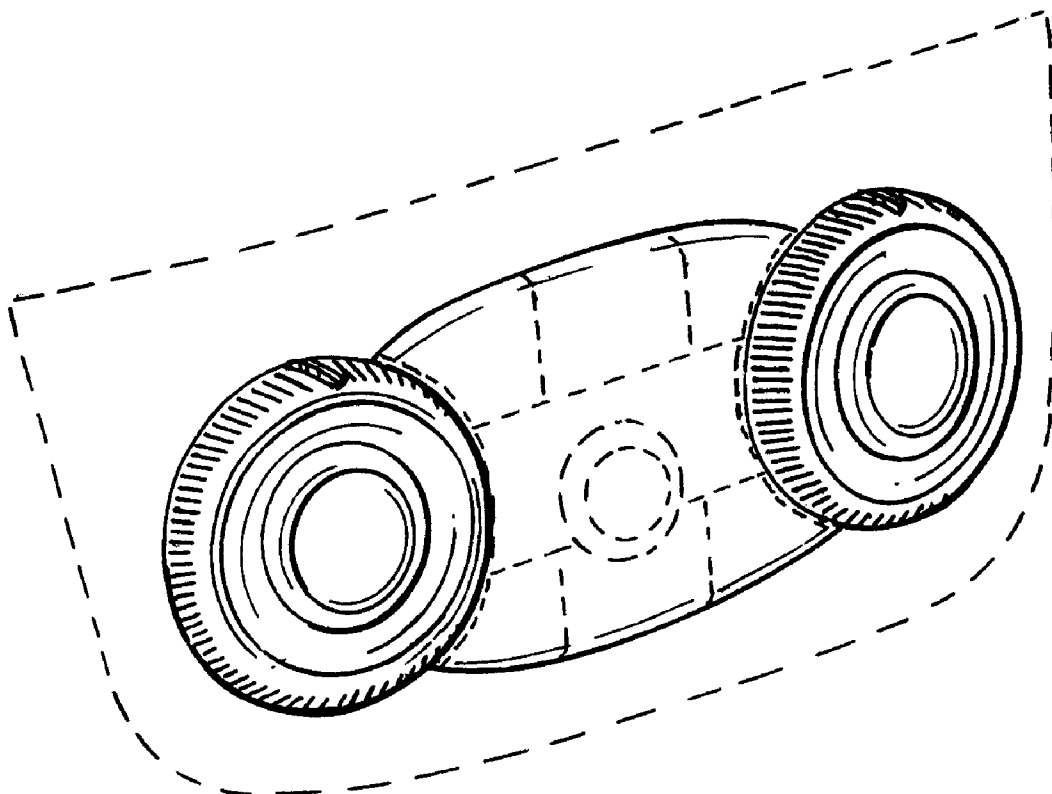

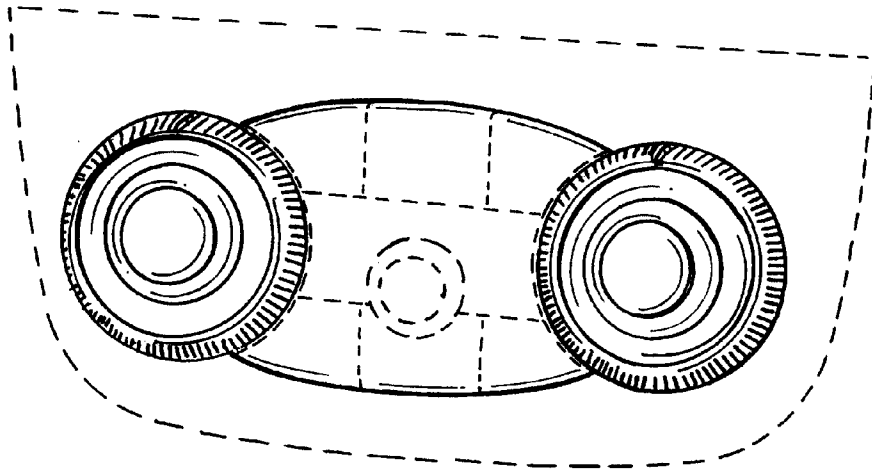

FIG. 1

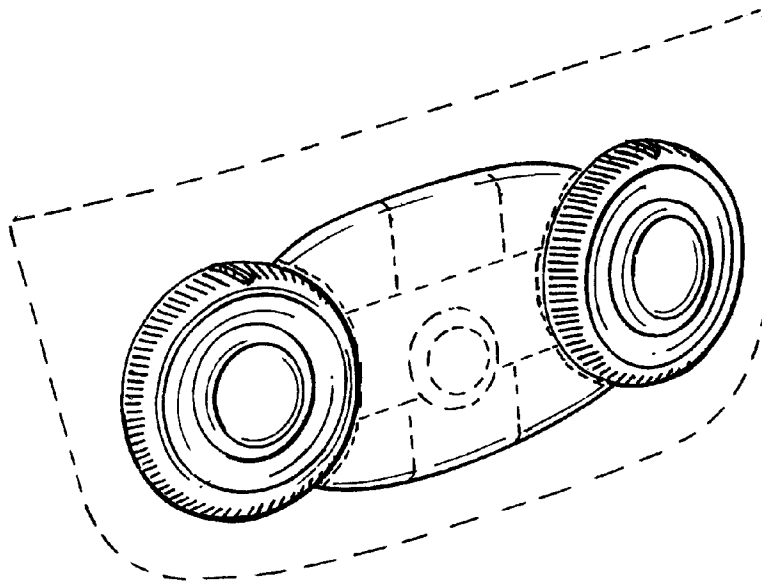

FIG. 2