

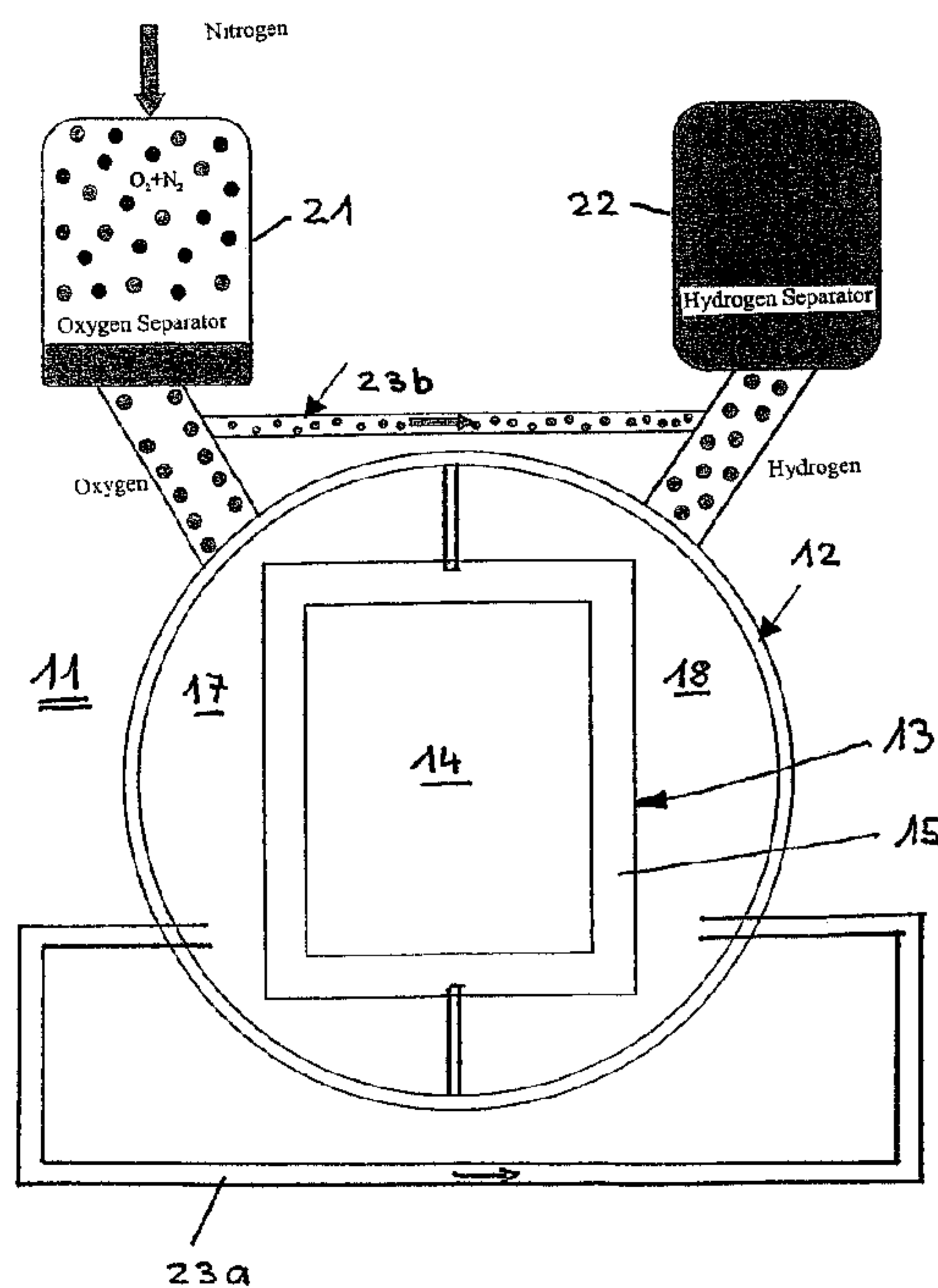

(86) Date de dépôt PCT/PCT Filing Date: 2003/12/10
 (87) Date publication PCT/PCT Publication Date: 2004/07/01
 (85) Entrée phase nationale/National Entry: 2005/06/13
 (86) N° demande PCT/PCT Application No.: EP 2003/013993
 (87) N° publication PCT/PCT Publication No.: 2004/055242
 (30) Priorité/Priority: 2002/12/14 (102 58 525.3) DE

(51) Cl.Int.⁷/Int.Cl.⁷ C25B 1/12, C25B 15/08, C25B 15/00
 (71) Demandeur/Applicant:
 GHW GESELLSCHAFT FUER
 HOCHLEISTUNGSELEKTROLYSEURE ZUR
 WASSERSTOFFERZEUGUNG MBH, DE
 (72) Inventeurs/Inventors:
 BRAND, ROLF AUGUST, DE;
 WALLEVIK, ODDMUND, NO
 (74) Agent: SIM & MCBURNEY

(54) Titre : DISPOSITIF D'ELECTROLYSE SOUS PRESSION ET SON PROCEDE D'ARRET
 (54) Title: PRESSURE ELECTROLYZER AND METHOD FOR SWITCHING OFF A PRESSURE ELECTROLYZER



(57) **Abrégé/Abstract:**

The invention relates to a pressure electrolyzer and a method for switching off said pressure electrolyzer. The pressure electrolyzer comprises a pressure reservoir (12) and an electrolytic cell block (13) which contains a plurality of electrolytic cells (14) and is arranged in the pressure reservoir (12), the electrolytic cells (14) including respective anodes and cathodes. An electrolyte circulation system supplies the anodes and cathodes with the electrolyte. An oxygen separator (21) separates the gaseous oxygen produced during operation of the pressure electrolyzer (11) and a hydrogen separator (22) separates the gaseous hydrogen produced during operation of the pressure electrolyzer (11). A supply of an inert gas, especially hydrogen, is used to render the pressure electrolyzer (11) inert when it is switched off. The invention is particularly characterized in that the inert gas supply is supplied to the oxygen separator (21) and that the electrolyte circulation system comprises a pipe connection (23a; 23b) via which a part of the electrolyte can be displaced in the sense of a displacement of the gaseous hydrogen from the hydrogen separator (22) when the oxygen separator (21) is impinged upon with the inert gas.

(12) NACH DEM VERTRAG ÜBER DIE INTERNATIONALE ZUSAMMENARBEIT AUF DEM GEBIET DES PATENTWESENS (PCT) VERÖFFENTLICHTE INTERNATIONALE ANMELDUNG

(19) Weltorganisation für geistiges Eigentum
Internationales Büro(43) Internationales Veröffentlichungsdatum
1. Juli 2004 (01.07.2004)

PCT

(10) Internationale Veröffentlichungsnummer
WO 2004/055242 A1

- (51) Internationale Patentklassifikation⁷: C25B 1/12, 15/00, 15/08
- (21) Internationales Aktenzeichen: PCT/EP2003/013993
- (22) Internationales Anmeldedatum:
10. Dezember 2003 (10.12.2003)
- (25) Einreichungssprache: Deutsch
- (26) Veröffentlichungssprache: Deutsch
- (30) Angaben zur Priorität:
102 58 525.3 14. Dezember 2002 (14.12.2002) DE
- (71) Anmelder (für alle Bestimmungsstaaten mit Ausnahme von US): **GESELLSCHAFT FÜR HOCHLEISTUNGSELEKTROLYSEUR ZURWASSERSTOFFERZEUGUNG MBH** [DE/DE]; Ludwig-Bölkow-Allee, Tor 2, 85521 Ottobrunn (DE).
- (72) Erfinder; und
- (75) Erfinder/Anmelder (nur für US): **BRAND, Rolf, August** [DE/DE]; Heufelder Strasse 76, 83052 Bruckmühl (DE). **WALLEVIK, Oddmund** [NO/NO]; Enggravhoegda 26, N-3711 Skien (NO).
- (74) Anwalt: **WINTER, Josef**; MTU Friedrichshafen GmbH, Abt. ZJ-P, Maybachplatz 1, 88045 Friedrichshafen (DE).

[Fortsetzung auf der nächsten Seite]

(54) Title: PRESSURE ELECTROLYZER AND METHOD FOR SWITCHING OFF A PRESSURE ELECTROLYZER

(54) Bezeichnung: DRUCKELEKTROLYSEUR UND VERFAHREN ZUR ABSCHALTUNG EINES DRUCKELEKTROLYSEURS

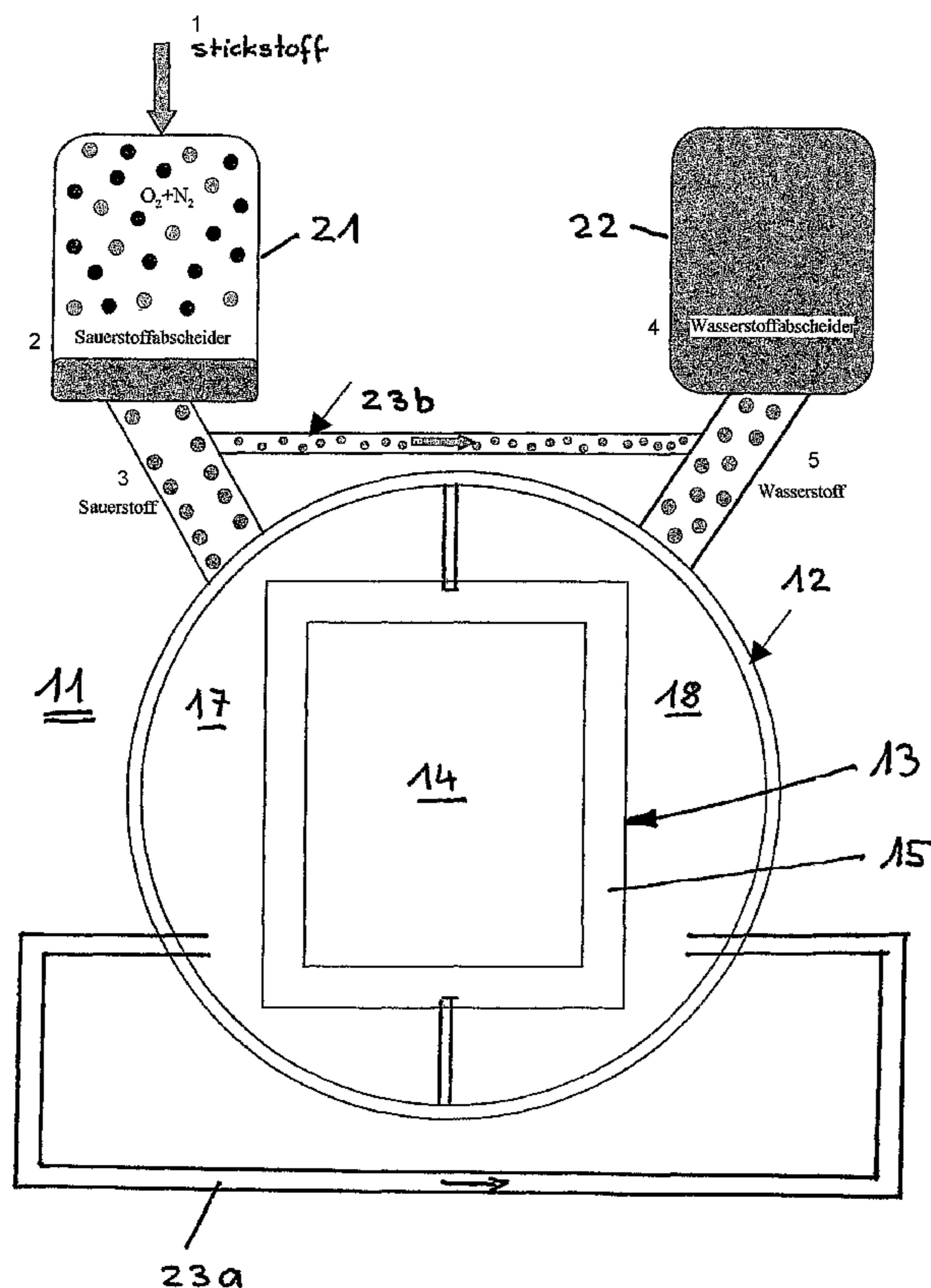
1 NITROGEN
2 OXYGEN SEPARATOR
3 OXYGEN4 HYDROGEN SEPARATOR
5 HYDROGEN

Sauerstoffabscheider

(57) Abstract: The invention relates to a pressure electrolyzer and a method for switching off said pressure electrolyzer. The pressure electrolyzer comprises a pressure reservoir (12) and an electrolytic cell block (13) which contains a plurality of electrolytic cells (14) and is arranged in the pressure reservoir (12), the electrolytic cells (14) including respective anodes and cathodes. An electrolyte circulation system supplies the anodes and cathodes with the electrolyte. An oxygen separator (21) separates the gaseous oxygen produced during operation of the pressure electrolyzer (11) and a hydrogen separator (22) separates the gaseous hydrogen produced during operation of the pressure electrolyzer (11). A supply of an inert gas, especially hydrogen, is used to render the pressure electrolyzer (11) inert when it is switched off. The invention is particularly characterized in that the inert gas supply is supplied to the oxygen separator (21) and that the electrolyte circulation system comprises a pipe connection (23a; 23b) via which a part of the electrolyte can be displaced in the sense of a displacement of the gaseous hydrogen from the hydrogen separator (22) when the oxygen separator (21) is impinged upon with the inert gas.

(57) Zusammenfassung: Es wird ein Druckelektrolyseur und ein Verfahren zum Abschalten eines solchen beschrieben. Der Druckelektrolyseur umfasst einen Druckbehälter (12) und einen eine Anzahl von Elektrolysezellen (14) enthaltenden, in dem Druckbehälter (12) angeordneten Elektrolysezellenblock (13), wobei die Elektrolysezellen (14) jeweilige Anoden und Kathoden enthalten und ein Elektrolytkreislaufsystem zur Zuführung von Elektrolyt zu den Anoden und Kathoden vorgesehen ist, einen

[Fortsetzung auf der nächsten Seite]

WO 2004/055242 A1

WO 2004/055242 A1

(81) **Bestimmungsstaaten** (*national*): CA, CN, IN, JP, NO, RU, US.

(84) **Bestimmungsstaaten** (*regional*): europäisches Patent (AT, BE, BG, CH, CY, CZ, DE, DK, EE, ES, FI, FR, GB, GR, HU, IE, IT, LU, MC, NL, PT, RO, SE, SI, SK, TR).

Veröffentlicht:

— mit internationalem Recherchenbericht

— vor Ablauf der für Änderungen der Ansprüche geltenden Frist; Veröffentlichung wird wiederholt, falls Änderungen eintreffen

Zur Erklärung der Zweibuchstaben-Codes und der anderen Abkürzungen wird auf die Erklärungen ("Guidance Notes on Codes and Abbreviations") am Anfang jeder regulären Ausgabe der PCT-Gazette verwiesen.

(21) zum Abscheiden des beim Betrieb des Druckelektrolyseurs (11) entstehenden gasförmigen Sauerstoffs und einem Wasserstoffabscheider (22) zum Abscheiden des beim Betrieb des Druckelektrolyseurs (11) entstehenden gasförmigen Wasserstoffs, sowie einen Vorrat eines inerten Gases, insbesondere Stickstoff, zum Inertisieren des Druckelektrolyseurs (11) bei seiner Abschaltung. Erfindungsgemäss ist es vorgesehen, dass der Inertgasvorrat dem Sauerstoffabscheider (21) zuführbar ist, und dass das Elektrolytkreislaufsystem eine Leitungsverbindung (23a; 23b) enthält, über die bei Beaufschlagung des Sauerstoffabscheiders (21) mit dem Inertgas ein Teil des Elektrolyten im Sinne einer Verdrängung des gasförmigen Wasserstoffs aus dem Wasserstoffabscheider (22) verschiebbar ist.

Pressure Electrolyzer and Method for Switching Off A
Pressure Electrolyzer

The invention relates to a pressure electrolyser in accordance with the pre-characterising clause of claim 1, and a process for switching off a pressure electrolyser in accordance with the pre-characterising clause of claim 9.

Pressure electrolysers which comprise a pressure reservoir and an electrolytic cell block which is positioned in the pressure reservoir and contains a number of electrolytic cells combined in the form of a stack are known for the electrolytic splitting of water into hydrogen and oxygen. The electrolytic cells contain anodes and cathodes, and an electrolyte circulatory system is provided for supplying electrolyte to the anodes and cathodes. An oxygen separator serves to separate the gaseous oxygen formed during the operation of the pressure electrolyser and a hydrogen separator serves to separate the gaseous hydrogen formed during the operation of the pressure electrolyser. In order to inert the pressure electrolyser when it is switched off a store of an inert gas, in particular nitrogen, is provided.

A pressure electrolyser of traditional type is known from DE 25 48 699 C3, for example.

A vital safety factor in pressure electrolysers of the type specified lies in their capacity to be inerted quickly, reliably and fully, i.e. in the removal of the hydrogen from the pressure reservoir and from the hydrogen separator, such that the residual hydrogen content is well below the lower explosion limit of 4% by vol.

Traditionally, large quantities of inert gas, typically nitrogen, are held ready for inerting, it being used to rinse the hydrogen out of the hydrogen separator when the electrolyser is switched off, in the event of an emergency shutdown, for example. To this end the pressure in the pressure electrolyser may either be maintained or reduced to ambient pressure in the course of rinsing with the inert gas. In any event, due to the mixing of the gases a, multiple of the gas volume of the hydrogen separator must be held ready in the form of inert gas.

Since, due to the evolution of hydrogen or oxygen in hidden caverns, decompressing the electrolyser at speed typically causes damage to the seals and structural components of the

cells and means that the subsequent restarting of the unpressurised plant is associated with considerable energy expenditure, the electrolyser should, where possible, only be decompressed in three, genuinely unavoidable emergency scenarios: an electrolyte leak, a product gas leak or a critical impurity in the product gas. In all other cases pressure should be maintained when the electrolyser is switched off.

The object of the invention is to create a pressure electrolyser and a process for switching off a pressure electrolyser in which the reliable inerting of the electrolyser is possible with a minimum amount of inert gas. In particular, but not exclusively, it should be possible to switch off the electrolyser without decompressing it.

This object is achieved in relation to the device by means of a pressure electrolyser with the features of claim 1.

This object is achieved in relation to the process by means of a process with the features of claim 9.

Advantageous versions of the invention are specified in the various subsidiary claims.

The invention creates a pressure electrolyser with a pressure reservoir and an electrolytic cell block which is positioned in the pressure reservoir and contains a number of electrolytic cells. The electrolytic cells contain anodes and cathodes and an electrolyte circulatory system is provided for supplying electrolyte to the anodes and cathodes. An oxygen separator is provided to separate the gaseous oxygen formed during the operation of the pressure electrolyser and a hydrogen separator is provided to separate the gaseous hydrogen formed during the operation of the pressure electrolyser. A store of an inert gas, in particular nitrogen, serves to inert the pressure electrolyser when it is switched off. In the invention the store of inert gas can be supplied to the oxygen separator and the electrolyte circulatory system contains a connecting line via which a part of the electrolyte can be pushed out of the hydrogen separator when the inert gas is applied to the oxygen separator, thereby displacing the gaseous hydrogen.

In one version of the pressure electrolyser disclosed in the invention, the oxygen separator and/or the hydrogen separator is provided outside the pressure reservoir and when the inert gas is applied to the oxygen separator a part of the electrolyte can be pushed from the pressure reservoir and/or the oxygen separator into the hydrogen separator in order to displace the hydrogen in the hydrogen separator.

In another preferred version of the invention the oxygen separator and/or the hydrogen separator is formed by a part of the volume within the pressure reservoir and when the inert gas is applied to the oxygen separator a part of the electrolyte can be pushed into the part of the pressure reservoir which forms the hydrogen separator in order to displace the hydrogen, in particular within the pressure reservoir.

In one version of the invention the connecting line via which a part of the electrolyte can be pushed out of the hydrogen separator by displacing the hydrogen is provided outside the pressure reservoir.

In this arrangement, the connecting line may take the form of a shuttle line which runs beneath the liquid level of the electrolyte and connects the oxygen separator to the hydrogen separator.

In an alternative version of the pressure electrolyser disclosed in the invention the connecting line via which a part of the electrolyte can be pushed out of the hydrogen separator, thereby displacing the hydrogen, is provided inside the pressure reservoir.

In an advantageous version of the pressure electrolyser disclosed in the invention, the housing of the electrolytic cell block and the pressure reservoir together form at least two separate chambers which are part of the electrolyte circulatory system and which are delimited from the electrolytic cells by the housing and from the environment by the pressure reservoir, one of the separate chambers being part of an anolyte circuit and connected to the oxygen separator and another of the separate chambers being part of a catholyte circuit and connected to the hydrogen separator.

In this arrangement, the separate chambers can be separated by dividing walls which extend from the housing of the electrolytic cell block and the pressure reservoir and the connecting line, via which a part of the electrolyte can be pushed out of the hydrogen separator, thereby displacing the hydrogen, can be formed by a passage in an area of the dividing walls which lies below the liquid level of the electrolyte.

Furthermore, the invention also creates a process for switching off a pressure electrolyser, the pressure electrolyser containing a pressure reservoir and an electrolytic cell block which comprises a number of electrolytic cells and is positioned in the pressure reservoir, the electrolytic cells containing anodes and cathodes and an electrolyte circulatory system being provided for the supply of electrolyte to the anodes and cathodes. An oxygen separator serves to separate the gaseous oxygen formed during the operation of the pressure electrolyser and a hydrogen separator serves to separate the gaseous hydrogen formed during the operation of the pressure electrolyser. To inert the pressure electrolyser, an inert gas, in particular nitrogen, is fed into the pressure electrolyser when it is switched off. In the invention, the inert gas is fed into the oxygen separator and when the inert gas is applied to the oxygen separator a part of the electrolyte is pushed out of the hydrogen separator via a connecting line provided in the electrolyte circulator system, thereby displacing the gaseous hydrogen.

In an advantageous version of the process disclosed in the invention the oxygen separator and/or the hydrogen separator is provided outside the pressure reservoir and when the inert gas is applied to the oxygen separator a part of the electrolyte is pushed from the pressure reservoir and/or from the oxygen separator into the hydrogen separator in order to displace the hydrogen in the hydrogen separator.

In another advantageous version of the process disclosed in the invention the oxygen separator and/or the hydrogen separator is formed by a part of the volume inside the pressure reservoir and when the inert gas is applied to the oxygen separator a part of the electrolyte is pushed into the part of the pressure reservoir volume forming the hydrogen separator in order to displace the hydrogen, in particular inside the pressure reservoir.

Various embodiments of the invention are explained below with reference to the drawings.

Figs. 1a) and 1b) show a schematised view of a pressure electrolyser as disclosed in the invention in operating mode (Fig. 1a) and in switched-off mode (Fig. 1b).

Figs. 2a) and 2b) show a schematised view of a pressure electrolyser as disclosed in the invention in operating mode (Fig. 2a) and in switched-off mode (Fig. 2b).

In Figs. 1a), 1b), 2a) and 2b) a pressure electrolyser referred to in its totality by the reference numerals (11/31) and used for the electrolytic splitting of water into hydrogen and oxygen comprises a pressure reservoir (12/32) in which is positioned an electrolytic cell block (13/33). The electrolytic cell block (13/33) consists of a number of electrolytic cells (14/34) combined in the form of a stack which are indicated only generally in the drawings. The electrolytic cells (14) each contain an anode and a cathode (not illustrated). An electrolyte circulatory system (of which only part is illustrated in the drawings) serves to supply electrolyte to the anodes and cathodes. An electrolyser of this type is described in the unpublished German patent application with the reference no. 101 50 557.4, for example.

In addition to the pressure reservoir (12), the embodiment illustrated in Figs. 1a) and 1b) also contains an oxygen separator (21) for separating the gaseous oxygen formed when the pressure electrolyser (11) is in operation and a hydrogen separator (22) for separating the gaseous hydrogen formed when the pressure electrolyser (11) is in operation.

In the embodiment illustrated in Figs. 2a) and 2b), the housing (35) of the electrolytic cell block (33) together with the pressure reservoir (32) forms two separate chambers (37, 38) which are separated from one another by dividing walls (39, 40) which extend between the housing (35) of the electrolytic cell block (33) and the pressure reservoir (32). The two separate chambers (37, 38) form part of the electrolyte circulatory system and are delimited from the electrolytic cells (34) by the housing (35) and from the environment by the pressure reservoir (32).

A part of the volume inside the pressure reservoir (32) which is located above the electrolytic cell block (33) forms an oxygen separator (41) for separating the gaseous oxygen formed during the operation of the pressure electrolyser (31) and a part of the volume inside the

pressure reservoir (32) which is also located above the electrolytic cell block (33) forms a hydrogen separator (42) for separating the gaseous hydrogen formed during the operation of the pressure electrolyser (31).

Of the two aforementioned separate chambers (37, 38) which form part of the electrolyte circulatory system, one, namely chamber (37), is part of an anolyte circuit and is connected to the part of the volume inside the pressure reservoir (32) which forms the oxygen separator (41), while the other chamber (38) is part of a catholyte circuit and is connected to the part of the volume inside the pressure reservoir (32) which forms the hydrogen separator (42).

In all the embodiments illustrated a store of an inert gas, in particular nitrogen, is provided for inerting the pressure electrolyser (11/31) when it is switched off. This store is not, however, illustrated in the drawings. This inert gas serves to rid the pressure electrolyser, and in particular the hydrogen separator (22/42), of hydrogen at least to the extent that the hydrogen content lies below the lower explosion limit of 4% by vol. In general terms, this store of inert gas or the inert gas held ready can be fed into the oxygen separator (21/41) in such a manner that when the inert gas is applied to the oxygen separator (21/41) a part of the electrolyte within the electrolyte circuit is pushed in such a manner that the gaseous hydrogen is forced out of the hydrogen separator (22/42). In this arrangement, the displaced hydrogen may be discharged into the environment, stored or removed in another manner, for example.

In order that the electrolyte in the electrolyte circulatory system can be pushed out of the hydrogen separator (22/42) as described above, thereby displacing the gaseous hydrogen, a connecting line (23a; 23b; 42a; 43b) is provided in the electrolyte circulatory system which may be of various designs.

In the embodiment illustrated in Figs. 1a) and 1b) the aforementioned connecting line is provided outside the pressure reservoir (12), two different versions thereof being illustrated in the same diagram. For example, the connecting line running outside the pressure reservoir (12) may be formed either by a connecting line (23a) which connects a volume area associated with the oxygen separator (21) inside the pressure reservoir (12) to a volume area associated with the hydrogen separator (22) inside the pressure reservoir (12), or by a shuttle line (23b) which connects the oxygen separator (21) to the hydrogen separator (22) and runs

beneath the liquid level of the electrolyte. Finally, the aforementioned connecting line may also connect an area of the electrolyte circuit associated with the oxygen separator (21) to an area of the electrolyte circuit associated with the hydrogen separator (22) inside the pressure reservoir (12) (although this version is not illustrated in Figs. 1a) and 1b)).

In the normal operating mode of the pressure electrolyser (11) illustrated in Fig. 1a), any oxygen formed is collected in the oxygen separator (21) and any hydrogen formed is collected in the hydrogen separator (22). Parts (namely the bottom) of both the oxygen separator (21) and the hydrogen separator (22) are filled with electrolyte, while the product gas in question collects in the upper area of the separator (21, 22).

When the pressure electrolyser (11) needs to be switched off, the inert gas held ready, typically nitrogen, is fed into the oxygen separator (21), typically in the upper volume area provided for the collection of the gaseous oxygen. Part of the electrolyte is then pushed via the connecting line (23a, 23b) provided in the electrolyte circuit out of the oxygen separator (21) and/or out of the pressure reservoir (12) into the hydrogen separator (22) where it displaces the gaseous hydrogen in said hydrogen separator (22), thereby inerting the pressure electrolyser (11) and the hydrogen separator (22). This inerting process does not usefully take place until essentially all the gaseous hydrogen has risen out of the pressure reservoir (12) into the hydrogen separator (22). Fig. 1b) shows the pressure electrolyser (11) in its switched-off, inerted state.

In the embodiment illustrated in Figs. 2a) and 2b) the connecting line (43a, 43b) via which a part of the electrolyte can be pushed out of the volume area of the pressure reservoir (32) forming the hydrogen separator (42), thereby displacing the gaseous hydrogen, is either formed by a connecting line (43a) running outside the pressure reservoir (32) which connects a chamber (37) forming the volume area of the pressure reservoir (32) associated with the oxygen separator (41), i.e. one part of the anolyte circuit, to a chamber (38) forming the volume area of the pressure reservoir (32) associated with the hydrogen separator (42), i.e. one part of the catholyte circuit, or there is provided inside the pressure reservoir (32) a connecting line (43b) which connects a chamber (37) forming the volume area of the pressure reservoir (32) associated with the oxygen separator (41), i.e. one part of the anolyte circuit, to

a chamber (38) forming the volume area of the pressure reservoir (32) associated with the hydrogen separator (42), i.e. one part of the catholyte circuit. This connecting line (43b) is typically provided in the dividing wall (40) beneath the electrolytic cell block (33).

When inerting the electrolyser (31), the inert gas held ready, typically nitrogen, is applied to volume area of the pressure reservoir (32) forming the oxygen separator (41), thereby transferring the electrolyte via the connecting line (43a/43b) out of the volume area of the pressure reservoir (32) associated with the oxygen separator (41), i.e. out of the chamber (37) of the anolyte circuit, into the volume area of the pressure reservoir (32) associated with the hydrogen separator (42), i.e. into the chamber (38) of the catholyte circuit, until the hydrogen has been completely removed from the volume area of the pressure reservoir (32) forming the hydrogen separator (42). Here, once again, inerting does not usefully take place until essentially all the hydrogen formed has collected in the hydrogen separator (42), i.e. in the corresponding volume area of the pressure reservoir (32).

In all the embodiments detailed, the pushing of the electrolyte level into the hydrogen separator (22/42) can be monitored by appropriate means, for example by level detectors which monitor the rise in level of the electrolyte in the hydrogen separator (22/42) up to a predetermined level.

The hydrogen displaced during the inerting of the hydrogen separator (22/42) can be stored and used again. It must not be disposed of since it is not mixed with the inert gas fed in.

The invention may be used with all types of electrolysers including, for example, PEM electrolysers which use water as the electrolyte.

List of reference numerals

11; 31	Pressure electrolyser
12; 32	Pressure reservoir
13; 33	Electrolytic cell block
14; 34	Electrolytic cells
15; 35	Housing
17; 37	Chamber for anolyte circuit
18; 38	Chamber for catholyte circuit
29	Dividing wall
40	Dividing wall
21; 41	Oxygen separator
22; 42	Hydrogen separator
23a; 43a	Connecting line
23b; 43b	Connecting line

Claims

1. A pressure electrolyser having a pressure reservoir (12; 32) and an electrolytic cell block (13; 33) containing a number of electrolytic cells (14; 34) and positioned in the pressure reservoir (12; 32), the electrolytic cells (14; 34) each containing anodes and cathodes and an electrolyte circulatory system for supplying electrolyte to the anodes and cathodes being provided, having an oxygen separator (21; 41) to separate the gaseous oxygen formed during the operation of the pressure electrolyser and a hydrogen separator (22; 42) to separate the gaseous hydrogen formed during the operation of the pressure electrolyser and having a store of an inert gas, in particular nitrogen, to inert the pressure electrolyser (11; 33) when it is switched off,

characterised in that

the store of inert gas can be supplied to the oxygen separator (21; 41), and the electrolyte circulatory system contains a connecting line (23a; 23b; 43a; 43b) via which a part of the electrolyte can be pushed out of the hydrogen separator (22; 42) when the inert gas is applied to the oxygen separator (21; 41), thereby displacing the gaseous hydrogen.

2. A pressure electrolyser in accordance with claim 1,

characterised in that

the oxygen separator (21) and/or the hydrogen separator (22) is provided outside the pressure reservoir (12) and when the inert gas is applied to the oxygen separator (21) a part of the electrolyte can be pushed by the pressure reservoir (12) and/or by the oxygen separator (21) into the hydrogen separator (22) in order to displace the hydrogen in the hydrogen separator (22).

3. A pressure electrolyser in accordance with claim 1,

characterised in that

the oxygen separator (41) and/or the hydrogen separator (42) is formed by a part of the volume inside the pressure reservoir (32), and when the inert gas is applied to the oxygen separator (41), a part of the electrolyte can be pushed into the part of the pressure reservoir volume forming the hydrogen separator (42) in order to displace the hydrogen.

4. A pressure electrolyser in accordance with claim 1, 2 or 3,
c h a r a c t e r i s e d i n t h a t
the connecting line (23a; 23b; 43a) via which a part of the electrolyte can be pushed out of the hydrogen separator (22; 42), thereby displacing the hydrogen, is provided outside the pressure reservoir (12; 32).
5. A pressure electrolyser in accordance with claim 4 in conjunction with claim 2,
c h a r a c t e r i s e d i n t h a t
the connecting line (23b) is formed by a shuttle line (23b) which runs beneath the liquid level of the electrolyte and connects the oxygen separator (21) to the hydrogen separator (22).
6. A pressure electrolyser in accordance with claim 1, 2 or 3,
c h a r a c t e r i s e d i n t h a t
the connecting line (43b) via which a part of the electrolyte can be pushed out of the hydrogen separator (42), thereby displacing the hydrogen, is provided inside the pressure reservoir (32).
7. A pressure electrolyser in accordance with one of claims 1 to 6,
c h a r a c t e r i s e d i n t h a t
the housing (35) of the electrolytic cell block (33) together with the pressure reservoir (32) form at least two separate chambers (37, 38) which are part of the electrolyte circulatory system and which are delimited from the electrolytic cells (34) by the housing (35) and from the environment by the pressure reservoir (32), one of the separate chambers (37) being part of an anolyte circuit and connected to the oxygen separator (41) and another of the separate chambers (38) being part of a catholyte circuit and connected to the hydrogen separator (42).
8. A pressure electrolyser in accordance with claim 7,
c h a r a c t e r i s e d i n t h a t
the separate chambers (37, 38) are separated from one another by dividing walls (39, 40) which extend between the housing (35) of the electrolytic cell block (33) and the pressure reservoir (32), and the connecting line (43b) via which a part of the electrolyte can be pushed out of the hydrogen separator (42), thereby displacing the hydrogen, is formed by a passage in an area of the dividing walls (39, 40) beneath the liquid level of the electrolyte.

9. A process for switching off a pressure electrolyser which comprises a pressure reservoir (12; 32) and an electrolytic cell block (13; 33) containing a number of electrolytic cells (14; 34) and positioned in the pressure reservoir (12; 32), the electrolytic cells (14; 34) each containing anodes and cathodes and an electrolyte circulatory system for supplying electrolyte to the anodes and cathodes, an oxygen separator (21; 41) to separate the gaseous oxygen formed during the operation of the pressure electrolyser (11; 31) and a hydrogen separator (22; 42) to separate the gaseous hydrogen formed during the operation of the pressure electrolyser (11; 31) being provided, an inert gas, in particular nitrogen, being fed to the pressure electrolyser (11; 31) to inert it when it is switched off,

characterised in that

the inert gas is fed to the oxygen separator (21; 41), and when the inert gas is applied to the oxygen separator (21; 41) a part of the electrolyte is pushed out of the hydrogen separator (22; 42) via a connecting line contained in the electrolyte circulatory system (23a; 23b; 43a; 43b), thereby displacing the gaseous hydrogen.

10. A process in accordance with claim 9,

characterised in that

the oxygen separator (21) and/or the hydrogen separator (22) is provided outside the pressure reservoir (12), and when the inert gas is applied to the oxygen separator (21), a part of the electrolyte is pushed by the pressure reservoir (12) and/or the oxygen separator (21) into the hydrogen separator (22) in order to displace the hydrogen in the hydrogen separator (22).

11. A process in accordance with claim 9,

characterised in that

the oxygen separator (41) and/or the hydrogen separator (42) is formed by a part of the volume inside the pressure reservoir (32) and when the inert gas is applied to the oxygen separator (41), a part of the electrolyte is pushed into the pressure reservoir volume forming the hydrogen separator (22) in order to displace the hydrogen.

Fig. 1a)

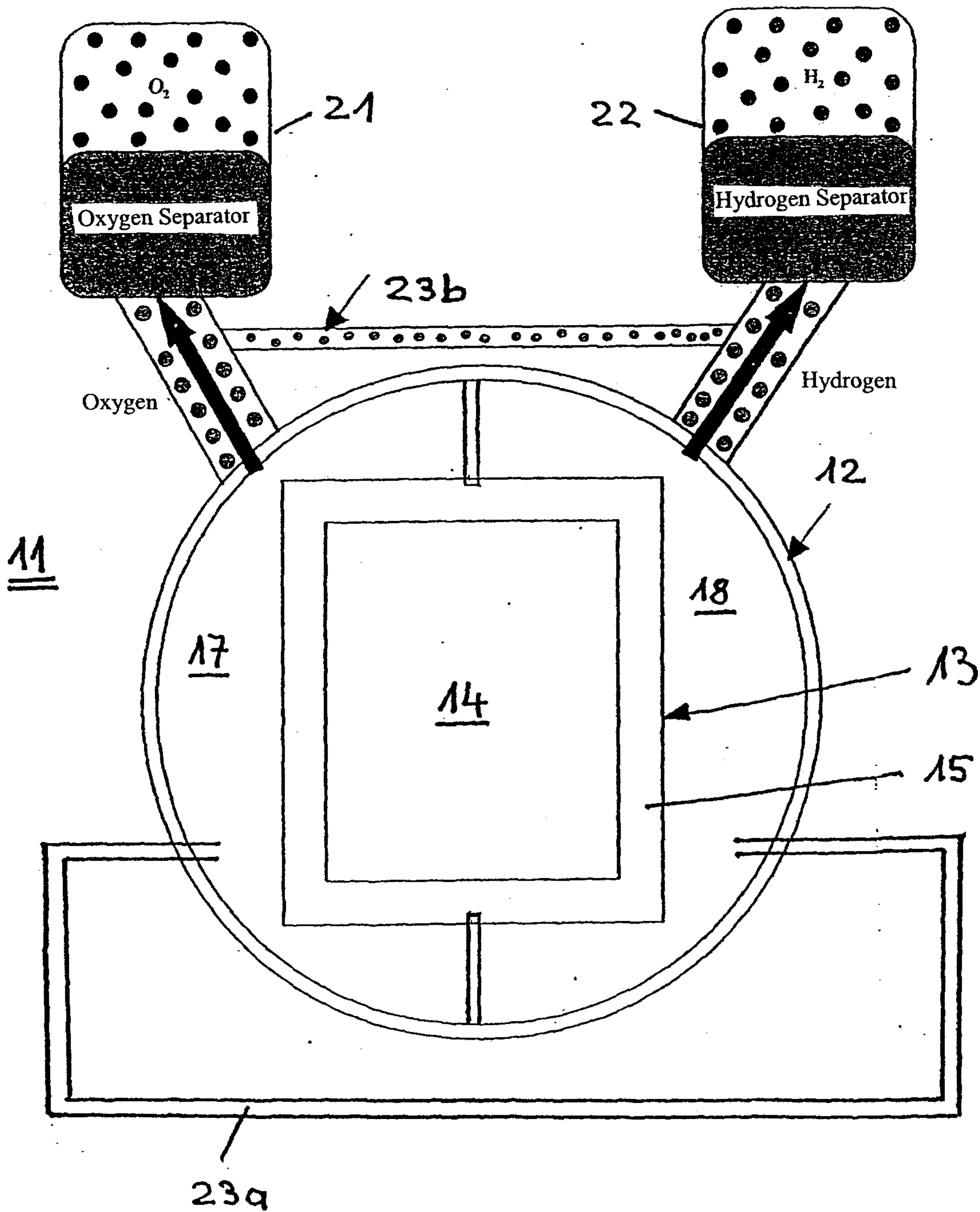

Fig. 1b)

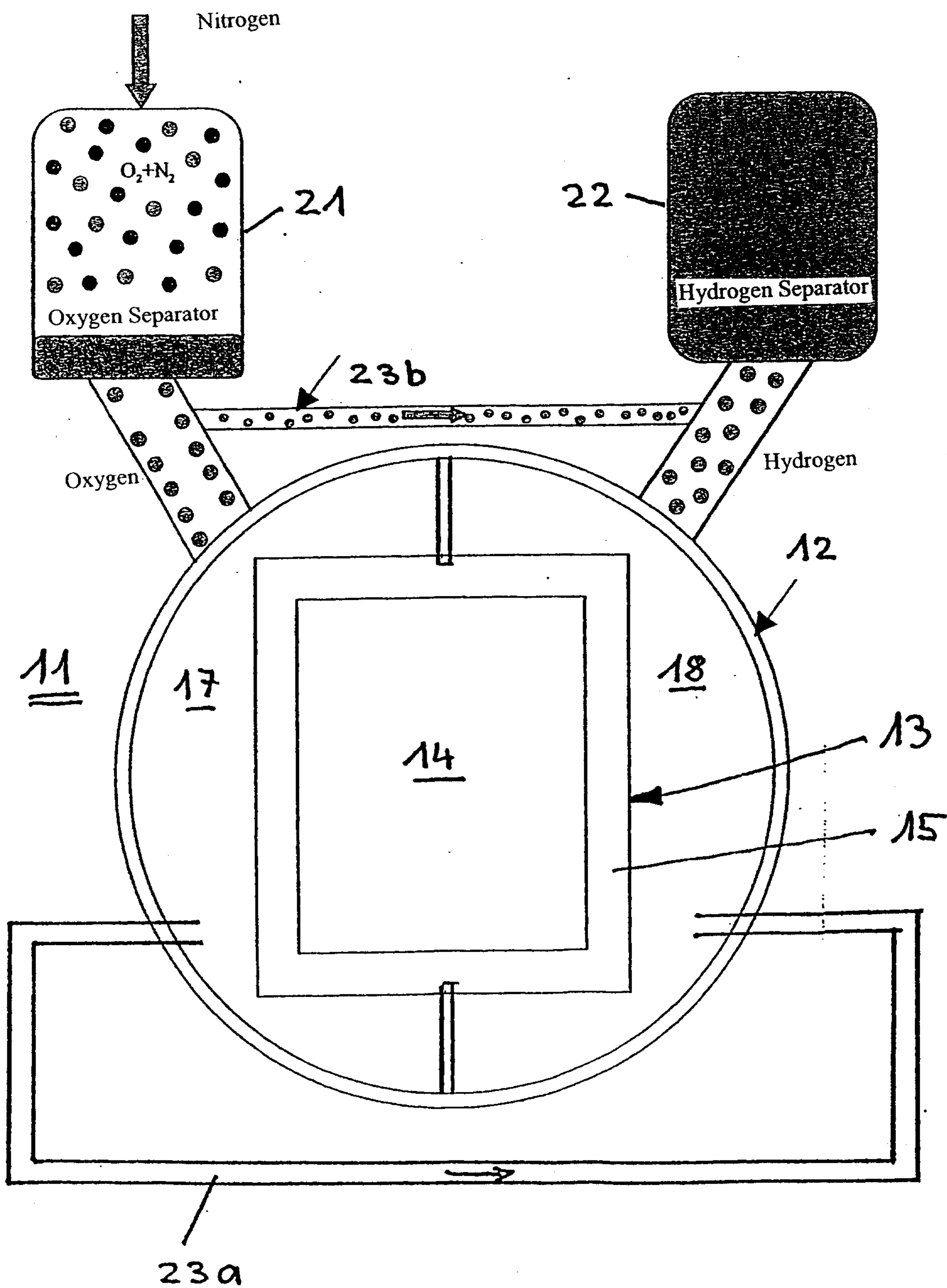

Fig. 2a)

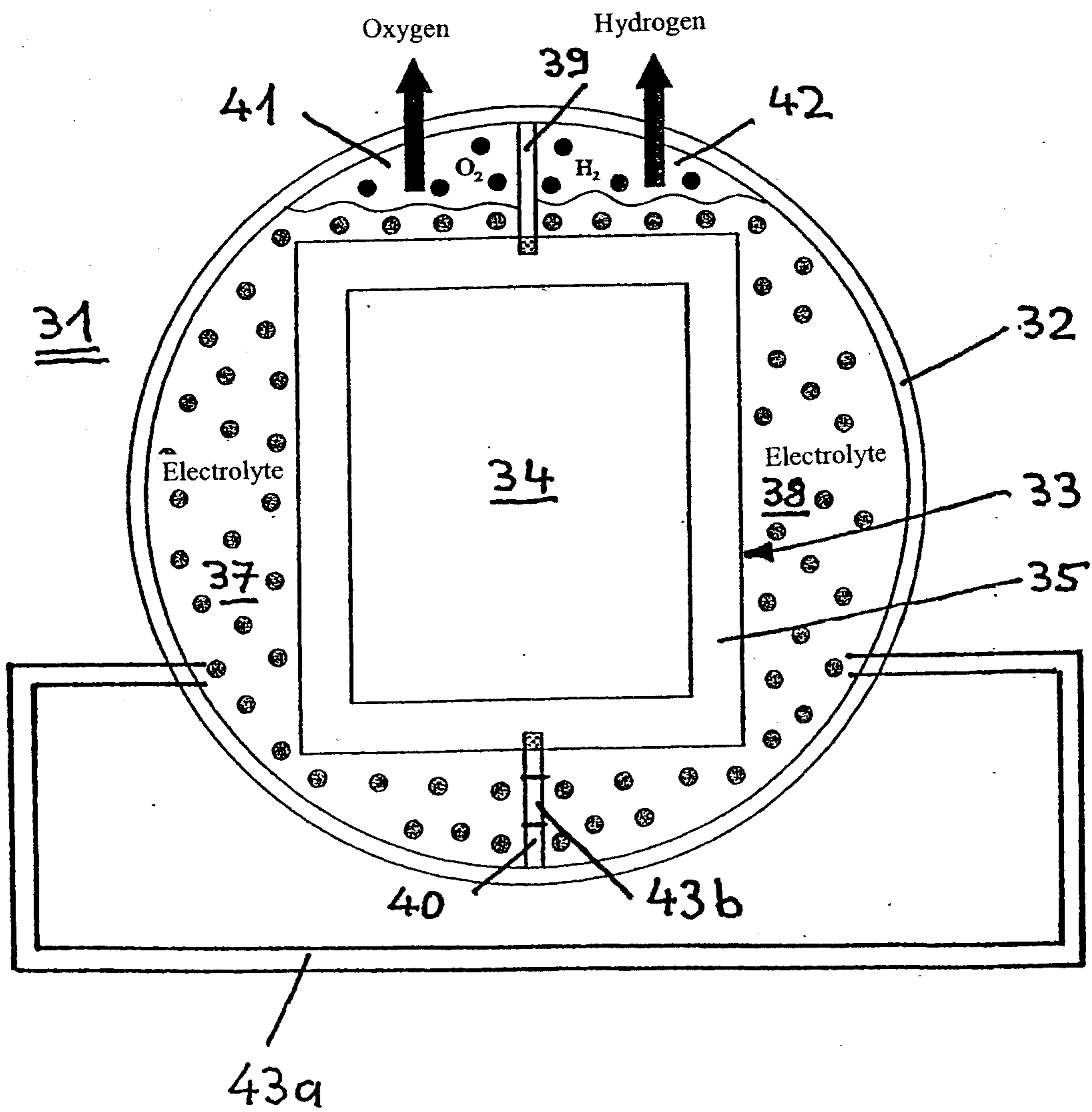
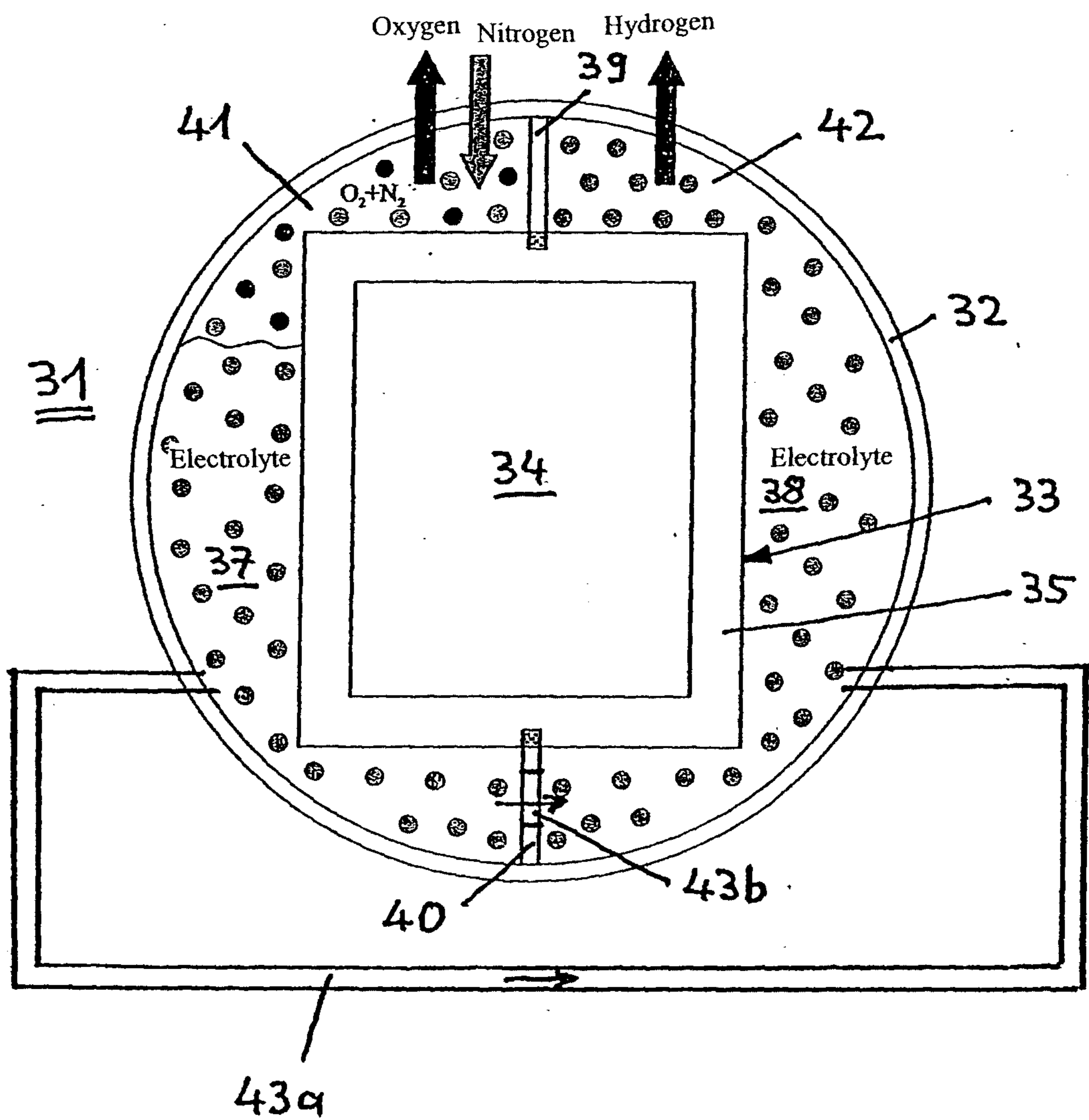
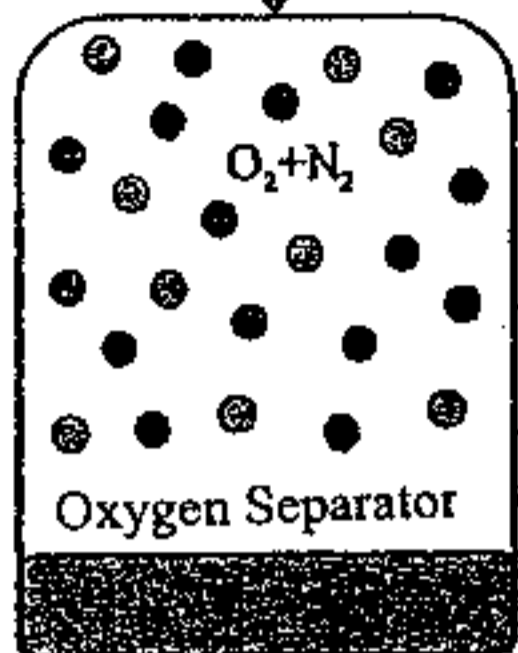

Fig. 2b)



Nitrogen



22

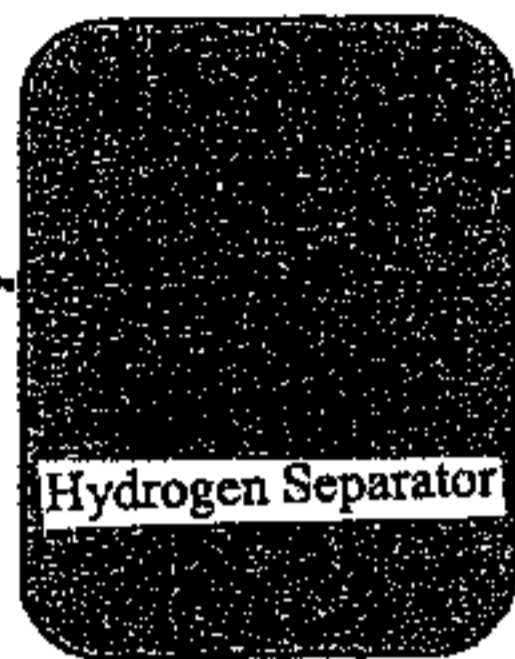

23b

Oxygen

Hydrogen

12

11

17

18

14

13

15

23a

