

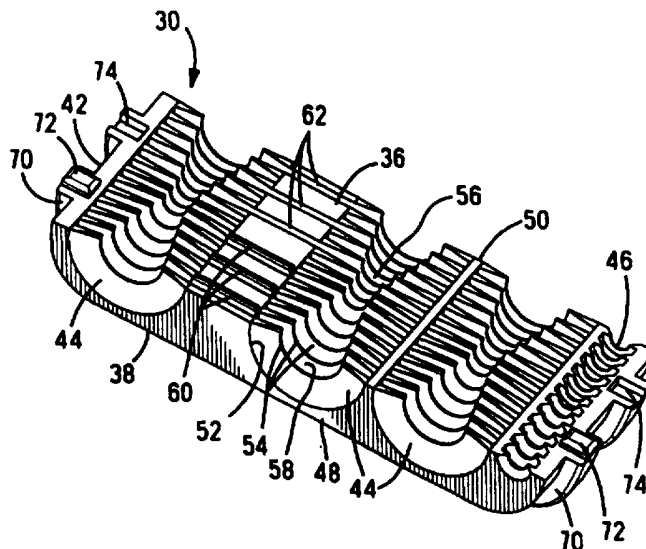

INTERNATIONAL APPLICATION PUBLISHED UNDER THE PATENT COOPERATION TREATY (PCT)

<p>(51) International Patent Classification ⁶ : G02B 6/44, H02G 15/013</p>	<p>A1</p>	<p>(11) International Publication Number: WO 97/41474</p> <p>(43) International Publication Date: 6 November 1997 (06.11.97)</p>
<p>(21) International Application Number: PCT/US97/07096</p> <p>(22) International Filing Date: 28 April 1997 (28.04.97)</p> <p>(30) Priority Data: 08/641,447 30 April 1996 (30.04.96) US 08/640,200 30 April 1996 (30.04.96) US</p> <p>(71) Applicant: THE WHITAKER CORPORATION [US/US]; Suite 450, 4550 New Linden Hill Road, Wilmington, DE 19808 (US).</p> <p>(72) Inventors: STOUGH, Robert, Eugene; 7189 Chambers Hill Road, Harrisburg, PA 17111 (US). GARVER, William, Joseph; 1012 Topview Road, Harrisburg, PA 17112 (US). STRICKLER, Scott, Allan; 22 S. Clinton Street, York, PA 17404 (US).</p> <p>(74) Agents: ANASTASI, Salvatore et al.; The Whitaker Corporation, Suite 450, 4550 New Linden Hill Road, Wilmington, DE 19808 (US).</p>		<p>(81) Designated States: BR, CA, CN, CZ, FI, HU, JP, KR, MX, NO, PL, RU, SG, European patent (AT, BE, CH, DE, DK, ES, FI, FR, GB, GR, IE, IT, LU, MC, NL, PT, SE).</p> <p>Published <i>With international search report.</i></p>

(54) Title: GROMMET FOR A FIBER OPTIC ENCLOSURE



(57) Abstract

The invention comprises a sealing grommet (30) having a body made of an elastomeric material. The body has two halves (34) to be assembled together in a sealing arrangement. The halves (34) have a cable receiving opening (32) extending therethrough from one side to another side. The opening (32) has an outer diameter with a series of pliable webs (54) extending inwardly into the opening (32) to form a cable receiving channel (44). The webs (54) in a center of the halves (34) are larger and extend further into the opening (32) than the webs (54) along the sides of the halves (34) thereby making the channel (44) narrower in the center of the halves (34) than along the sides of the halves (34) to enable a sealing relationship to be formed about a variety of cable sizes.

FOR THE PURPOSES OF INFORMATION ONLY

Codes used to identify States party to the PCT on the front pages of pamphlets publishing international applications under the PCT.

AL	Albania	ES	Spain	LS	Lesotho	SI	Slovenia
AM	Armenia	FI	Finland	LT	Lithuania	SK	Slovakia
AT	Austria	FR	France	LU	Luxembourg	SN	Senegal
AU	Australia	GA	Gabon	LV	Latvia	SZ	Swaziland
AZ	Azerbaijan	GB	United Kingdom	MC	Monaco	TD	Chad
BA	Bosnia and Herzegovina	GE	Georgia	MD	Republic of Moldova	TG	Togo
BB	Barbados	GH	Ghana	MG	Madagascar	TJ	Tajikistan
BE	Belgium	GN	Guinea	MK	The former Yugoslav Republic of Macedonia	TM	Turkmenistan
BF	Burkina Faso	GR	Greece	ML	Mali	TR	Turkey
BG	Bulgaria	HU	Hungary	MN	Mongolia	TT	Trinidad and Tobago
BJ	Benin	IE	Ireland	MR	Mauritania	UA	Ukraine
BR	Brazil	IL	Israel	MW	Malawi	UG	Uganda
BY	Belarus	IS	Iceland	MX	Mexico	US	United States of America
CA	Canada	IT	Italy	NE	Niger	UZ	Uzbekistan
CF	Central African Republic	JP	Japan	NL	Netherlands	VN	Viet Nam
CG	Congo	KE	Kenya	NO	Norway	YU	Yugoslavia
CH	Switzerland	KG	Kyrgyzstan	NZ	New Zealand	ZW	Zimbabwe
CI	Côte d'Ivoire	KP	Democratic People's Republic of Korea	PL	Poland		
CM	Cameroon	KR	Republic of Korea	PT	Portugal		
CN	China	KZ	Kazakstan	RO	Romania		
CU	Cuba	LC	Saint Lucia	RU	Russian Federation		
CZ	Czech Republic	LI	Liechtenstein	SD	Sudan		
DE	Germany	LK	Sri Lanka	SE	Sweden		
DK	Denmark	LR	Liberia	SG	Singapore		
EE	Estonia						

Grommet for a Fiber Optic Enclosure

The present invention relates to a grommet for sealing a fiber optic enclosure.

5 Aerial splice enclosures for telecommunications cable, and more specifically for fiber optic cables, are of various design. US Patent No. 4,831,215 discloses an aerial enclosure having a seal disposed in each end of the enclosure to provide protection to the interior of
10 the enclosure from moisture from the environment. The seals are provided in two halves which are received in either half of the aerial enclosure. The seals have ribs which extend interiorly into the opening to provide a good sealing relationship between the seal and the
15 fiber optic cable.

US Patent No. 4,701,574 discloses a cable end seal which provides a barrier against water where the cable enters the enclosure. The seals are placed at the entry point for the cable and placed under compression in
20 order to provide a good seal around the entry point for the cable.

What is needed is to provide a seal which can provide a good sealing engagement around fiber optic cables of varying sizes.

25 What is also needed is a plug to plug unused openings within the grommet to prevent water from entering an enclosure.

The invention comprises a sealing grommet having a body made of an elastomeric material. The body has two
30 halves to be assembled together in a sealing arrangement. The halves have a cable receiving opening extending therethrough from one side to another side. The opening has an outer diameter with a series of pliable webs extending inwardly into the opening to form
35 a cable receiving channel. The webs in a center of the halves are larger and extend further into the opening

than the webs along the sides of the halves thereby making the channel narrower in the center of the halves than along the sides of the halves to enable a sealing relationship to be formed about a variety of cable sizes.

Embodiments of the present invention will now be described by way of example with reference to the accompanying drawings, in which:

Figure 1 is an isometric view of the enclosure of the present invention;

Figure 2 is a partial isometric view showing the entry end of the enclosure with the grommet and plug of the present invention;

Figure 3 is an isometric view showing the enclosure open with the grommet and plug of the present invention, and showing a representative fiber optic tray;

Figure 4 is an isometric view showing the grommet and the plug installed within the enclosure;

Figure 5 is an isometric view of the grommet;

Figure 6 is a rear view of an alternative embodiment of the grommet;

Figure 7 is a front view of the alternative embodiment;

Figure 8 is a top view of the grommet with representations of different sizes of cables that can be received within the grommet;

Figure 9 is an isometric view of the plug of the present invention;

Figure 10 is a side view of the plug;

Figure 11 is an isometric view of one half of the plug;

Figure 12 is an isometric view of the fiber optic tray of the present invention;

Figure 13 is a close up view showing one of the raceways of the present invention;

Figure 14 is a top view of the fiber optic tray showing a representation of the optical fiber to be received within the tray;

5 Figure 15 is a partial isometric view of the raceway plug of the present invention; and

Figure 16 is a cross sectional view showing the raceway plug in conjunction with the raceway.

10 Figure 1 shows generally a fiber optic splice enclosure 10 which is used along an aerial fiber optic cable 12. The fiber optic cable 12 is an aerial cable which is extended between utility poles. The fiber optic enclosure 10 is installed on the aerial fiber optic cable between the utility poles. The enclosure 10 is used to splice one or more optical fibers from the
15 fiber optic cable 12 to a tap fiber of tap cable 14. The enclosure is secured to a messenger cable 16 and hangs from the cable 16 which extends between the utility poles also. The enclosure is secured to the cable by use of a hangar 18 which is connected from the
20 fiber optic splice enclosure 10 to the auxiliary cable 16. The enclosure is a durable dielectric material which is made out of two halves which are hinged together along one side and latched together along the other side. The fiber optic cable and the tap fiber
25 extend into the enclosure from either end of the enclosure through an entry portion.

Along either end of the enclosure, in the entry openings 20, are grommets 30 which are used to seal up the entry openings 20 around the fiber optic cable 12
30 and the tap cable 14 extending into the enclosure 10. The grommets on either end have three openings as is shown in Figure 2. The openings 32 are designed to receive the fiber optic cable or a tap fiber therethrough. When the openings are not being used, it
35 is necessary to plug up the openings to prevent moisture from getting inside the fiber optic enclosure 10. In

order to accomplish this, plug 80 is secured into the opening 32 to prevent moisture from getting inside the enclosure. The enclosure 10 is secured along an aerial fiber optic cable 12 and it is therefore important to
5 protect the inside of the enclosure against driven rain. The grommet 30 and the plug 80 of the present invention are designed to provide this protection.

Figure 3 shows the fiber optic enclosure 10 of the current invention with the hinged enclosure open. As
10 can be seen more clearly, the two halves are secured together along the one side by hinges. The representative embodiment shows that the enclosure has resilient latches for securing the enclosure closed. However, some other means could be used to secure the
15 enclosure such as screws, or any other type of closing means. The enclosure is made out of a durable dielectric material as was described earlier. Preferably, it is a double layer, blow molded plastic enclosure to provide the strength needed to protect the
20 fiber cables in the field.

The fiber optic enclosure 10 also includes a fiber optic splice tray represented at 99. The fiber optic splice tray is used to splice an input fiber from the fiber optic cable 12 to a tap fiber from the tap cable
25 14, to provide service, for example, into a customer's home. The fiber optic splice tray 99 shown in Figure 3 is a representative example. The fiber optic splice tray of the current invention will be described more fully hereinafter.

30 The grommet 30 of the present invention will now be described in more detail. The grommet has a two part body which is secured in an end opening of the fiber optic enclosure 10. As was described earlier, the grommet when closed has three openings 32 which extend
35 from the exterior of the enclosure to the interior of the enclosure. The grommet is made up of individual

hermaphroditic halves 34, as seen in Figure 3. The grommet has a front face 36 and a rearward face 38 and ends 42, as seen in Figure 5. Along the front face 36 are channels 44. There are three channels to receive either a fiber optic cable or a tap cable. A fourth channel 46, disposed along one end, is designed to receive an arm of the hanger 18 to provide a seal about the access for the hanger. The hanger is used to secure the inside of the fiber optic enclosure, the fiber optic cable 12, and the fiber optic tray to the auxiliary cable 16.

Each of the channels 44 comprise a series of webs which extend from one side 48 to the other side 50. The channel 44 has an approximately constant outer dimension 52. Along the length of the channel, a series of webs 54 extend inwardly from the outer dimension 52 to an inner dimension of the individual web 54. As can be seen in Figure 5, the webs get larger as you move from one side, towards the center of the grommet, and then get smaller as you proceed to the opposite side. The effect of this is to provide a cable receiving channel 56 which gets narrower as you approach the center of the grommet. The individual webs 54 have spaces 58 therebetween.

The grommet is made of a pliable dielectric material which allow the webs in combination with the spaces to flex about depending on the size of the cable received within the cable receiving channel 56. The grommet can be made from silicone rubber, polyurethane, or any other material which would provide the necessary pliability. The grommet also has a series of positioning teeth 60 and a series of positioning recesses 62. When two of the hermaphroditic halves are brought together, the positioning teeth 60 on one half are received within the positioning recess 62 on the other half thereby positioning the two halves of the

grommet together and ensuring that they are correctly aligned and, further, keeping them secured against each other.

Figure 8 is a representation of the effect of
5 securing different size wires within the grommet 30. On
the left hand side of Figure 8 it can be seen that a
relatively larger cable is received within the cable
receiving channel 56 as can be seen from the ghost
10 outlines indicated at 64. When the cable 64 is received
down within the channel 56, the cable 64 will engage the
series of webs almost all the way through the channel
with the exception of the two outermost webs on either
side of the grommet. Because the grommet is made out of
15 a pliable dielectric material, the web along the center
of the cable receiving channel will be pushed out of the
way and conform around the outer periphery of the cable
64. The tight fit between the webs 54 and the cable 64
provides an effective seal against ingress of water from
20 the exterior of the enclosure to the interior of the
enclosure.

On the right hand side in Figure 8, there is shown
the effect of having the smaller cable diameter secured
within the grommet 30. The smaller cable is shown along
25 the right hand side of Figure and is represented by
ghost lines at 66. As can be seen, the smaller cable
engages only those webs which are along the very center
of the cable receiving channel 56, that is the center
most five webs will engage the outer diameter of cable
66. These webs along the center will be deformed
30 against the outer diameter of the cable, thereby
providing a tight fit between those webs and the cable.
This tight fit will also prevent ingress of water from
the outer environment of the enclosure to the interior
of the enclosure. Therefore the effect of the grommet
35 of the current invention is to provide effect sealing

means against cables of a varying diameters from ingress of water through the grommet.

Figure 7 shows an alternative embodiment of the grommet of the present invention. The grommet 30' is also made out of hermaphroditic halves 34' and forms openings 32' when two halves are brought together. The grommet also has channels 44' for receiving fiber optic cables and channel 46' for receiving an arm of the hanger. The channels have outer dimensions 52' which remain approximately continuous from one side of the grommet to the other side. The webs 54' extend from the outer dimension of the channel 44' into the interior of the channel 44' forming cable receiving channel 56'. Rather than having a smooth conical shape formed by the varying sizes of the webs, the first four webs along the outer side are approximately the same size. The next webs project further in towards the interior to form a narrower channel towards the center. It is not a continuous change from the outer most webs towards the center most webs, instead the change can be described as stepped from the outermost webs to the innermost webs. The four outermost webs are approximately the same size providing the cable receiving channel with approximately the same diameter in that region. The next web is a little bit larger providing a smaller channel. The inner three most webs are approximately the same size providing the narrowest portion of the channel 56'. While the dimensions of the webs 54' and grommet 30' vary from the early embodiment, the effect of the grommet is exactly the same. The centermost webs will engage the smallest diameter cable while a larger cable will engage both the centermost webs and also the webs along the outer side of the channel, thereby providing a good seal against the ingress of water on both small diameter cables and larger diameter cables.

Figure 6 shows the rearward face of the grommet 30'. The rearward face has ribs 70' extending from one end to the other. The ribs are provided to retain the grommet 30' within the fiber optic enclosure 10. The fiber optic enclosure 10 has complementary recesses which receive the ribs 70' thereby keeping the grommet within the enclosure in the proper location and to provide a sealing engagement between the grommet 30' and the walls of the enclosure 10. Along ends of the ribs in either the embodiment shown in Figure 5 or that which is shown in Figure 7 are protrusion 72' and recesses 74'. When the hermaphroditic halves 34' are brought together in either the embodiments the protrusion 72' on one of the halves 34' will be received within the opening 74' on the mating hermaphroditic half 34 thereby providing additional alignment between the two hermaphroditic halves of the grommet and to secure the halves together. The embodiment of the grommet 30 shown in Figure 5 has similar ribs 70, protrusions 72 and recesses 74 and will engage the enclosure 10 in a similar manner.

The operation of the grommet within the enclosure 10 is shown in detail in Figure 4. The grommet is received within the entry opening of the enclosure, one half 34 is received in one half of the enclosure, the other half of the grommet is received in the other half of the enclosure. The fiber optic cable is received in the cable receiving channel 56 displacing those webs with which it engages. Therefore, when the enclosure is closed, the two hermaphroditic halves 34 of the grommet 30 engage each other along the entry point of the enclosure thereby securing the cable within the grommet and preventing water from entering the interior of the enclosure.

As can be seen in Figure 3, when the enclosure has one fiber optic cable 12 extending completely through

and only one tap cable 14 extending into the enclosure, there are three additional openings 32 within the grommets which are not being utilized. It is important to have these extra openings to provide flexibility for the technician when installing the cable into the enclosure from different directions. In order to prevent moisture from getting into the interior of the enclosure through these openings, it is necessary to place a plug within the openings. The plug 80 of the current invention is shown in Figure 3, with further detail shown in Figures 4, 9-10. The plug 80 is made up of two halves 82 which are joined together at a break section 84. The break section 84 is a narrow piece of plastic which is designed to be broken in the event that only one half of the plug is needed. Figure 3 shows an example of where the whole plug 80 is used and also where one half of the plug is used. On the right hand side of the enclosure in Figure 3 there are two openings which need to be plugged. Therefore, the entire plug 80 is placed within these two openings, thereby sealing up both of the openings. On the other hand, on the left hand side of the enclosure, a tap fiber is extending through one of the openings so therefore it is only necessary to use one half 82 of the plug 80 to secure up the additional opening 32. Therefore, the plug 80 is broken in half by placing a small amount of pressure along the break section 84.

The plug has a wall 86 which acts as an outer sealing member and is received along the exterior of the grommet 30. The plug has a cylindrical tower 88 which extends from the interior portions of the wall 86. The two towers are spaced from each other the same distance as two adjacent openings 32 on the grommet 30. Slightly offset from the wall 86 is disk 90 which extends from the cylindrical tower and acts as an inner sealing member. The disk being an integral part of the

cylindrical tower but offset from the wall 86 thereby forming a space between the disk 90 and the wall 86. On the cylindrical tower 88, on the end opposite of the wall 86, is a hold down through hole 92. This hold down
5 can be used to secure the plug within the grommet by a tie wrap secured to the inside of the enclosure or some other type of securing means.

The use of the plug is shown in detail in Figure 4. Whether the plug 80 is used as a whole or just as one
10 half, the cylindrical tower is received along the cable receiving channel 56 thereby engaging the webs 54 to provide a tight fit along the channel. To provide additional sealing, the disk 90 is received between two consecutive webs spaced slightly off from the side of
15 the grommet. In particular, the disk is received between the second and the third web from the exterior side of the grommet as is shown in Figure 4. The wall 86 is received along the exterior side of the grommet thereby completely sealing the openings 32 from ingress
20 of moisture into the interior of the enclosure. The combination of the tower being sealed against the webs of the channel and the disk and wall provide effective sealing against driven rain. Additionally, the hold downs 92 can be secured on the inside of the enclosure
25 by tie wraps which are not shown in Figure 4. The plug 80 will operate in a similar fashion if it is first broken in half and used to only plug up one opening 32. The only difference being that only one of these plugs will be used and the wall will only extend part way
30 along the exterior of the grommet.

Figure 3 shows a representative fiber optic splice tray disposed on the interior of the fiber optic enclosure 10. This fiber optic splice tray would house fiber optic splices for connecting an input fiber with
35 an output fiber to direct optical impulses into the output fiber. These are typically used to provide the

through signal to an output fiber directed to a converter box to convert the optical signal to an electrical signal for customer wiring in either a home or a business.

5 In Figure 3, it can be seen that the represented fiber optic tray 99 includes extensions 98 on either side which are secured to a hanger portion 20. This hanger portion 20 is then secured to the hanger 18 which secures the fiber optic enclosures to the messenger
10 cable 16. The hanger portion 24 has three serrated portions 22 such as alternating ribs and grooves over which the through fiber and the tap fiber are secured. The through fiber and the tap fiber are secured to the hanger portion 20 in these regions using hose clamps.
15 The serrated portion provides a good gripping surface on which to secure the fibers. This prevents the fibers from slipping side to side in relation to the hanger portion. The hanger portion 20 is then secured to hanger 18 providing good support for the interior
20 workings of the enclosure 10.

The fiber optic splice tray of the current invention will now be described with reference to Figures 12-16. Figure 12 shows the fiber optic tray 100 of the present invention. The tray 100 has a front face
25 102 along which the fiber optic management system is disposed. Along one edge of the tray is express buffer channel 104. The express buffer channel runs from one end to the other along the one edge and provides a channel for receiving the express buffer fiber or the
30 bundle of fiber optic cables that are not to be used as an input fiber, in other words, those fibers that will just be running through the enclosure without being modified. Along either end of the express buffer channel are serrated sections 106. The serrated
35 sections have a series of grooves and ribs to form a textured surface along which the through fiber can be

secured. The serrated sections have indentations 108 and through holes 110. These are used in cooperation with a hose clamp to secure the through cable to the tray 100. This will be combined with the hangar portion to connect the tray to the hangar and ultimately, to the messenger cable 16. A wall 112 separates the express buffer channel from the fiber optic management system 114 thereby preventing the through fiber from becoming intermingled with the input fiber and the tap fibers.

The fiber optic management system comprises three individual raceways 116 and 118. The smaller, more circular raceways 116, disposed on either end of the fiber optic management system, are to receive the input fiber which comes off of the through cable. The central raceway 116 is to receive the tap fiber from the tap cable 14. While the raceways are shown as being approximately circular or oval shaped, the raceways could be designed in any type of shape which allows the fibers to be retained and still maintain the appropriate bend radiuses. Disposed between the raceways 118 and 116 are fiber optic connector receiving areas 120. The receiving areas 120 are designed to receive a panel of fiber optic connectors 132 to connect the input fiber with the tap fiber. Disposed along wall 112 is an express fiber channel 122. The express fiber channel is a narrow channel designed to receive any of the fibers that are part of the bundle from which the input fiber is received, however, they will not be involved in the tap connection. Those fibers are received along the express fiber channel 122 and join the through fiber on either end of the tray 100.

Each of the raceways are designed using a series of walls 123 formed in circular or oval shapes defining narrow channels 124 therebetween. The shapes are designed to ensure that the optical fibers maintain the appropriate bend radiuses. The channels 124 are

designed to receive the input fiber therein. An input optical fiber will be mounted within one of the raceways 116 on either end of the fiber optic management system. The raceway 116 to be used depends on the direction that the optical signal is traveling. The raceway 116 that will be used is that which is closest to the source of the optical signal. In Figure 12, if the optical signal were going through the through fiber from right to left, the raceway 116 on the right side of the tray 100 would be the one to be used to manage the input fiber.

Figure 14 shows a representation of how the fibers will be installed within the channels. The input fiber 130 is threaded into the raceway 116 such that the fiber is received into the channel 124 between the upstanding walls 123. The input fiber 130 is arranged around the circle of the raceway 116 to take up any extra slack. When the end of the input fiber is reached, the input fiber is then threaded into the center portion of the raceway 116 by exiting out of the exit area 126. The exit area 126 is an opening between the walls of the raceway allowing the fiber to exit the channel 124 and enter the center portion 128 of the raceway. The fiber can be arranged within the center portion 128 to take up additional slack and to align the fiber for entry into one of the fiber optic splice connectors 132. The input fiber is then fed into the fiber optic connector 132 which is received in the fiber optic connector receiving area 120 and connected to the one side of the connector for splicing with the connector.

When it is time for another technician to install the tap fiber, it is not necessary for the technician to touch any of the input optical fiber 130 that has been installed in the raceway 116. At this point, the input fiber is completely secured inside its own management system and there is no need for any additional manipulation. The tap fiber 140 will be secured within

raceway 118 separate from the raceway 116 such that the technician does not need to, in any way, manipulate the input fiber. The tap fiber is brought along the channels from either end of the tray 100 and is threaded through the raceway 118 and arranged in the channels in a circular fashion. Again when the end of the tap fiber is approached, it will exit out of the channels through the exit area 134 into the center portion 134 of the raceway 118 to be fed to the opposite side of the fiber optic connector 132 which is disposed in the fiber optic connector receiving area. Raceway 118 has four exit areas 134. These exit areas provide flexibility in storing the tap fiber within the raceway. If there is a lot of slack to be taken up within the raceway, the tap fiber can be weaved in and out of the raceway by entering and exiting the channels through the exit areas 128. Any extra slack can therefore be maintained also within the center portion 138 of the raceway 118.

The typical fiber optic tray requires a cover to be received over the whole tray in order to ensure that the optical fibers are maintained in their correct position. In the fiber optic management system of the current invention, no such cover is necessary. The raceways define narrow channels 124 in which plug 148 can be received to secure the fiber optic cables within the channel. Plug 148 is made out of a flexible material which can be bent to fit within the curves of the raceway 116 or 118. Once the fibers are arranged in the raceways within the narrow channel, the plug can be pushed into the channels in an interference fit with the walls 123 of the channels 124 thereby securing the cables within the channels. The plug has a narrow section 142 and a handle section 144. The handle section 144 can be used by the technician to hold onto the plug. The narrow section 142 is received down in between the walls of the raceway within the channels 124

in an interference fit. The plug has a certain length shown and can be cut to accommodate the different lengths or whatever length is needed for the specific purpose. Alternatively, the plug can be cut into small
5 pieces which can be distributed about the periphery of the raceway thereby conserving material.

The advantages of the fiber optic management system of the tray shown are that the technician who initially
10 installs the fiber optic enclosure on the aerial fiber optic cable can also install the input cable within the fiber optic management system in a specified area. Later when it comes time to tap into the fiber optic cable such as to run a line to a customer's home or
15 business, the technician who will install the tap fiber does not need to disturb the input fiber as it has already been installed in its necessary position. Instead, the technician can install the input fiber in a separate area in its own management system, thereby insuring that the cables do not get entangled or messed
20 up to the identity of which cable is which. A further advantage of the fiber optic cable management system of the present invention is that it is not necessary to have a separate cover member to keep the fiber optic cables contained. The plug member can be cut to any
25 length and be installed at different places throughout the raceway thereby eliminating the need for a separate cover. A further advantage of the present invention is that the tray can be secured directly to the through fiber within the fiber optic enclosure.

30 The grommet, plug and fiber optic management system of the present invention and many of its attendant advantages will be understood from the foregoing description. It is apparent that various changes may be made in the form, construction, and arrangement of parts
35 thereof without departing from the spirit or scope of

the invention, or sacrificing all of its material advantages.

What is Claimed is:

1. A sealing grommet 30, having a body being made of an elastomeric material, the body having two halves 34 to be assembled together in a sealing arrangement, the halves 34 having a cable receiving opening 32 extending therethrough from one side to another side, characterized by:

the opening 32 having an outer diameter with a series of pliable webs 54 extending inwardly into the opening 32 to form a cable receiving channel 44, the webs 54 in a center of the halves being larger and extending further into the opening 32 than the webs 54 along the sides 48 of the halves 34 thereby making the channel 44 narrower in the center of the halves 34 than along the sides 48 of the halves 34 to enable a sealing relationship to be formed about a variety of cable sizes.

2. The grommet 30 of claim 1, wherein the webs 54 have recesses 58 therebetween to allow deflection of the webs 54 when a cable is received within the cable receiving channel 44.

3. The grommet 30 of claim 1, wherein the cable receiving channel 44 is conical in shape, the webs 54 getting bigger from the outermost webs 54 to the center most web 54, thereby forming back to back conical shapes with the narrowest part of the conical shape being joined.

4. The grommet 30 of claim 1, wherein the cable receiving channel 44 becomes narrower from the outermost web 54 to the center most web 54 in a series of steps, wherein several webs 54 are the same size and the next group of webs 54 are larger forming a narrower channel 44.

5. The grommet 30 of claim 1, wherein the body is made from silicone rubber.

5 6. The grommet 30 of claim 1, wherein the body is made from polyurethane.

7. The grommet 30 of claim 1, wherein the body halves 34 are hermaphroditic, each of the halves 34
10 having a protrusion 72 and each of the halves 34 having a recess 74, when the halves 34 are assembled together, the protrusion 72 on one of the halves 34 is received within the recess 74 on the other of the halves 34, thereby securing and aligning the halves 34 together.

15 8. The grommet 30 of claim 1, wherein the opening 32 extends along a front face 36 of the body, the body having a rear face 38 with retaining ribs 70 extending therealong, the ribs 70 providing alignment with an
20 opening of an enclosure and providing sealing between the body and the enclosure.

9. The grommet 30 of claim 1, wherein the body has an additional opening with webs extending therealong to
25 form a second channel 46, the second channel 46 being of equal diameter along the entire length of the second channel 46, whereby the second channel 46 can receive a device of a given size.

30

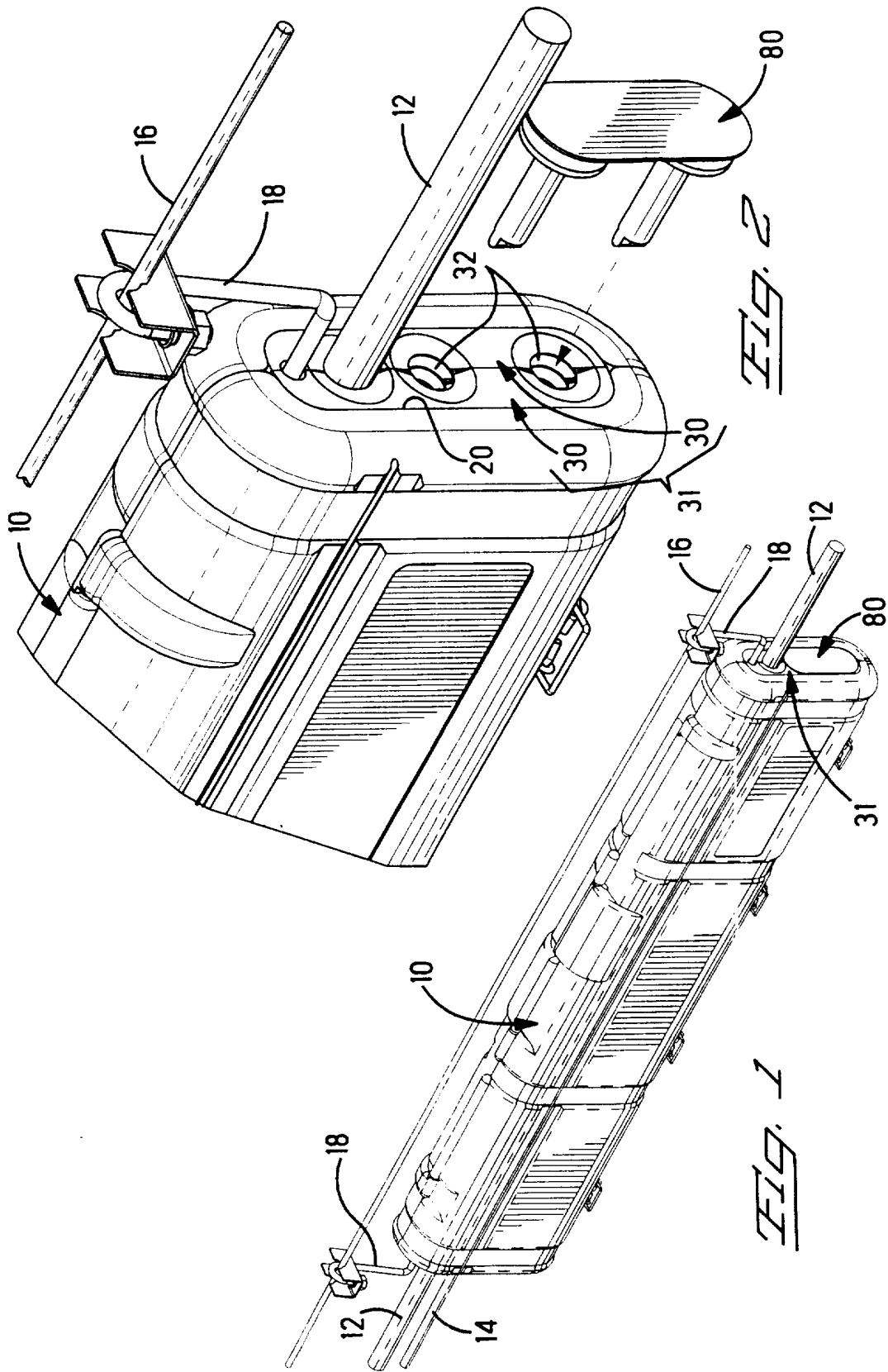

FIG. 2

FIG. 1

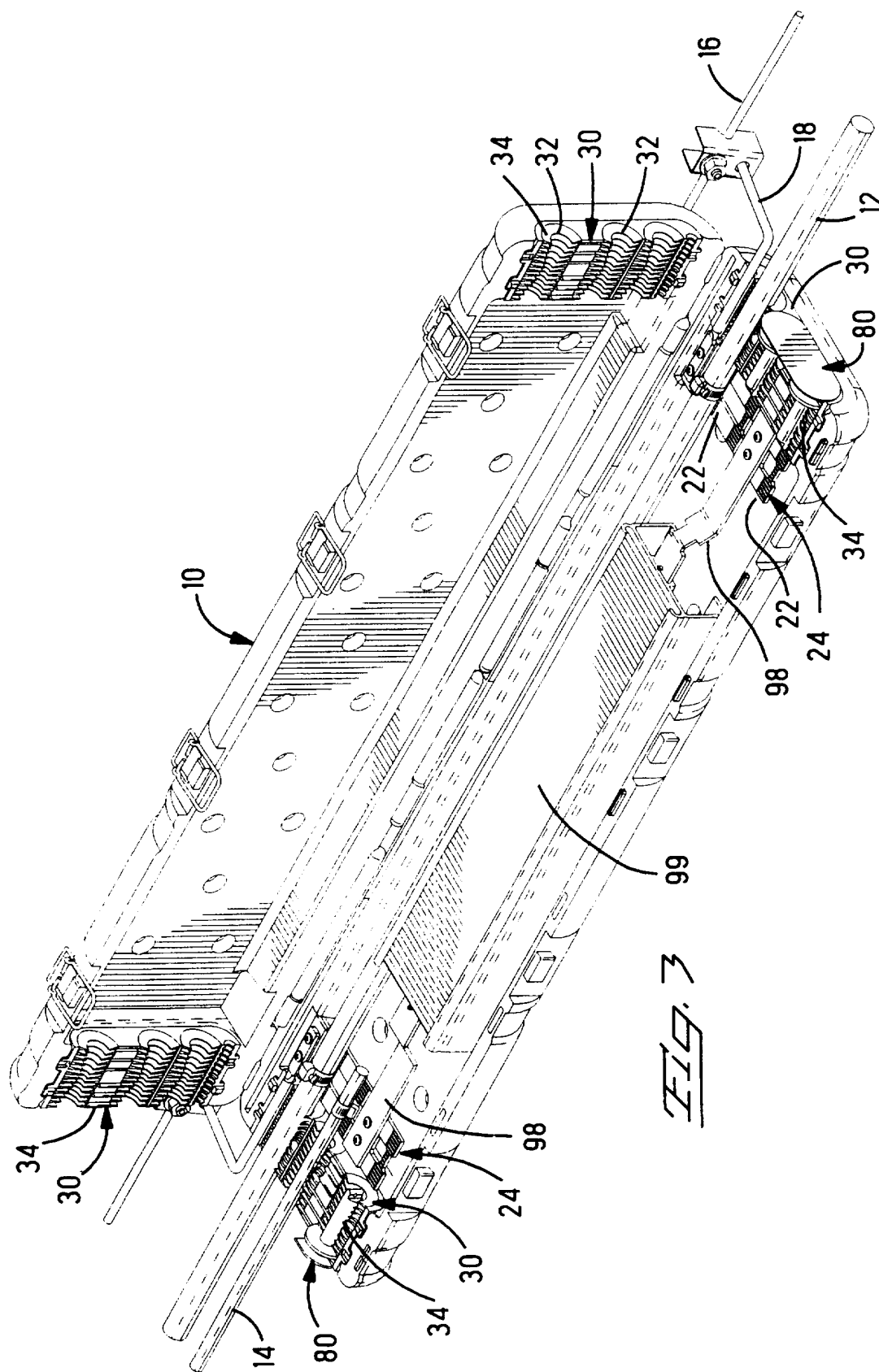

FIG. 3

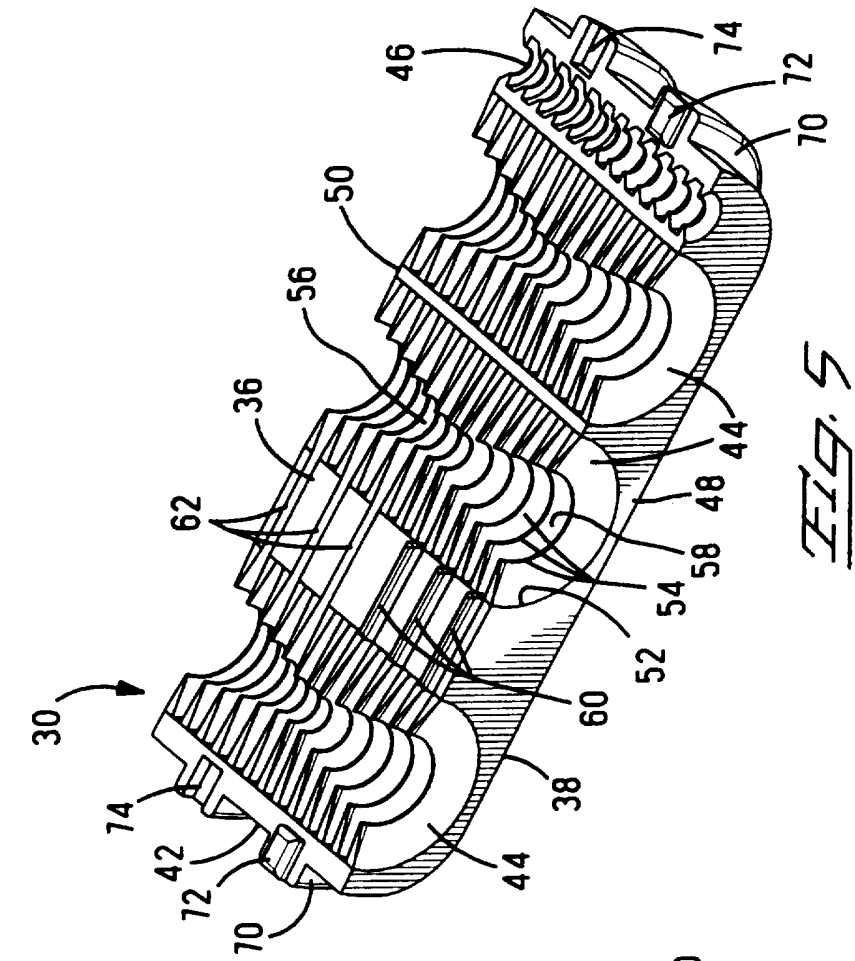

FIG. 5

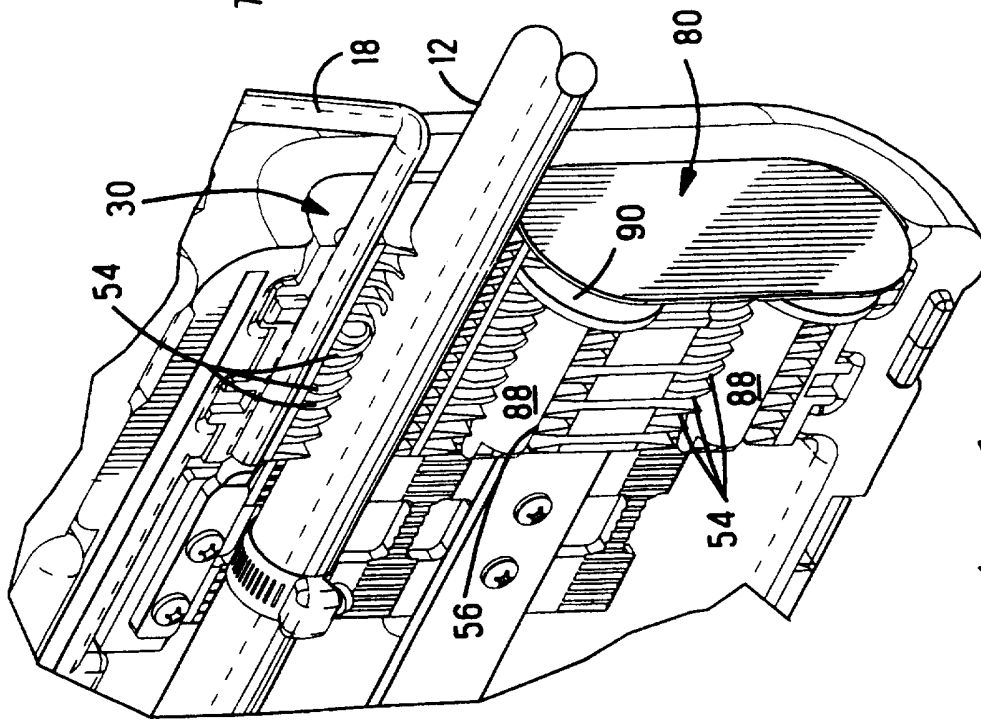

FIG. 4

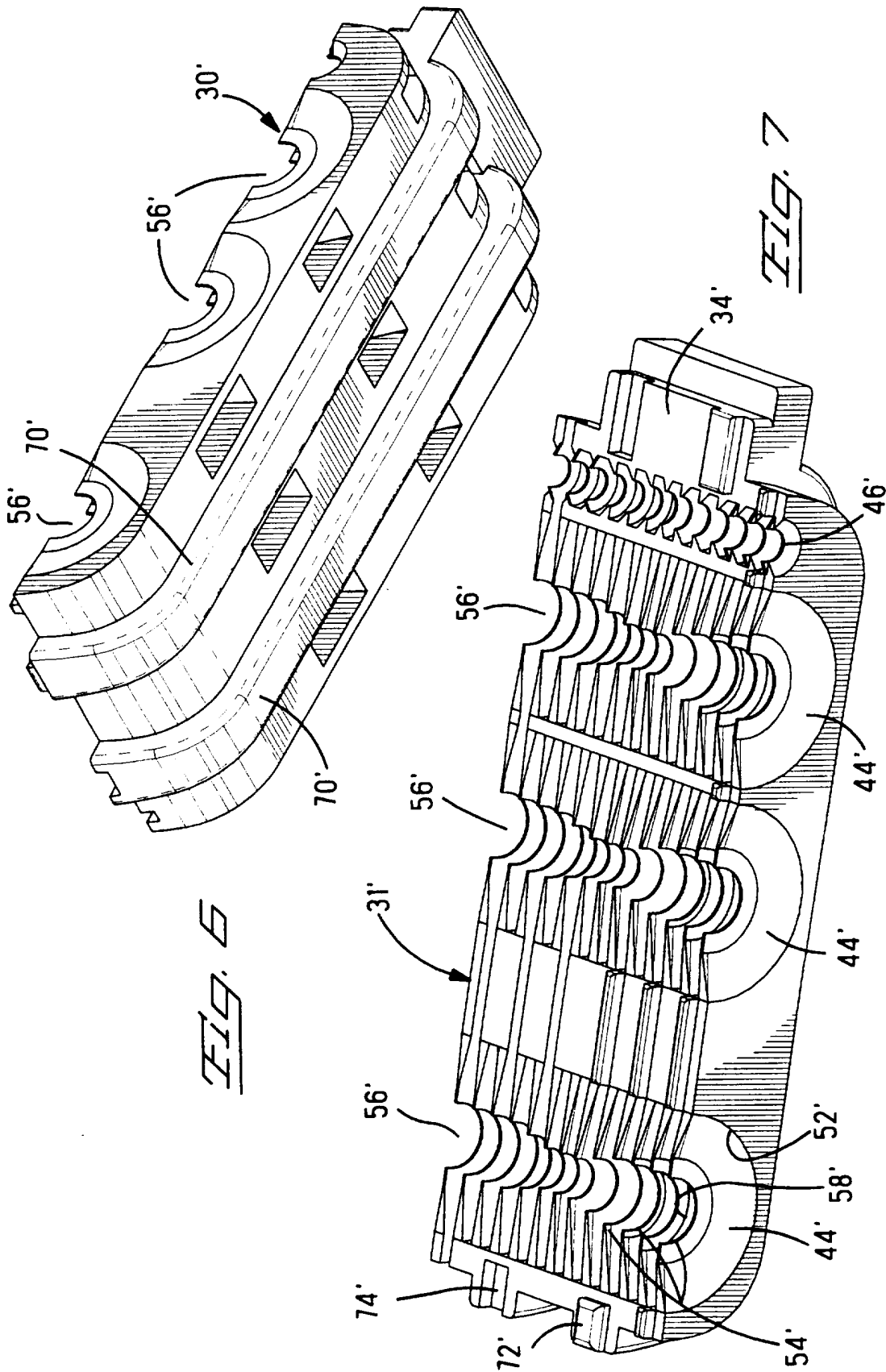

FIG. 6

FIG. 7

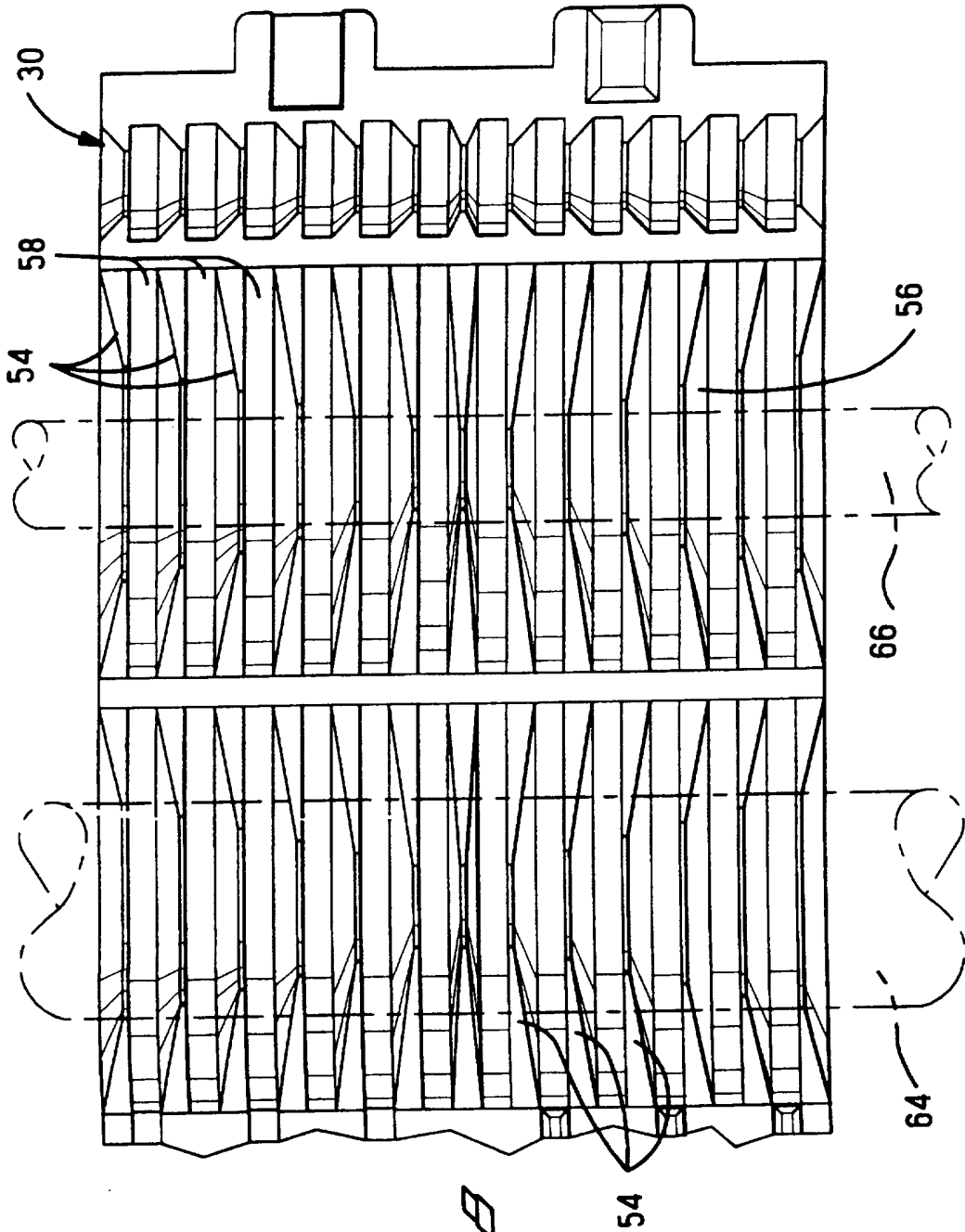

FIG. 8

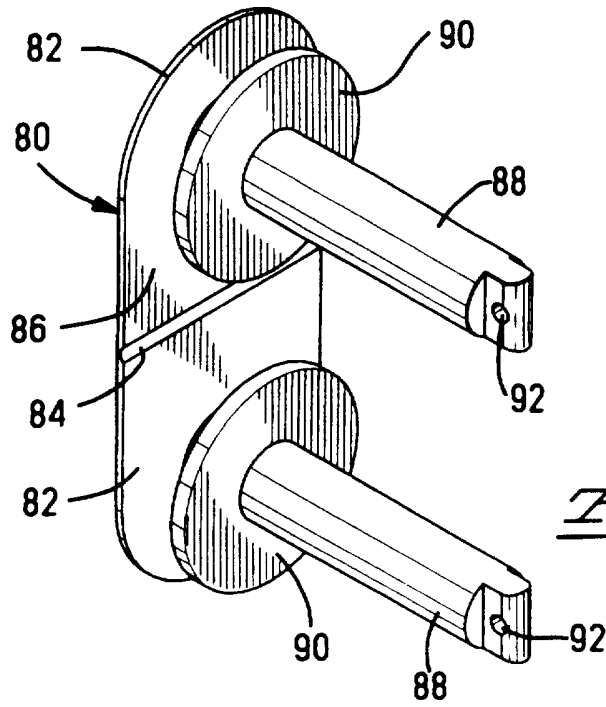

Fig. 9

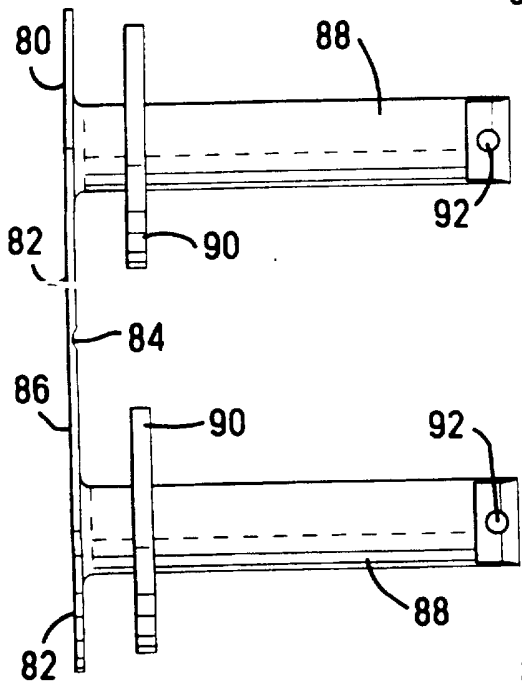
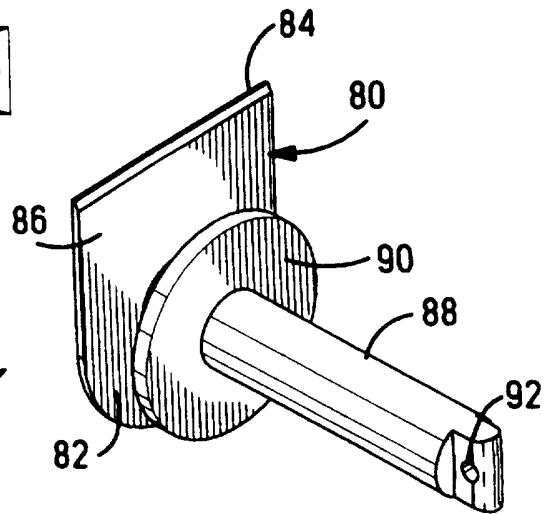

Fig. 10

Fig. 11



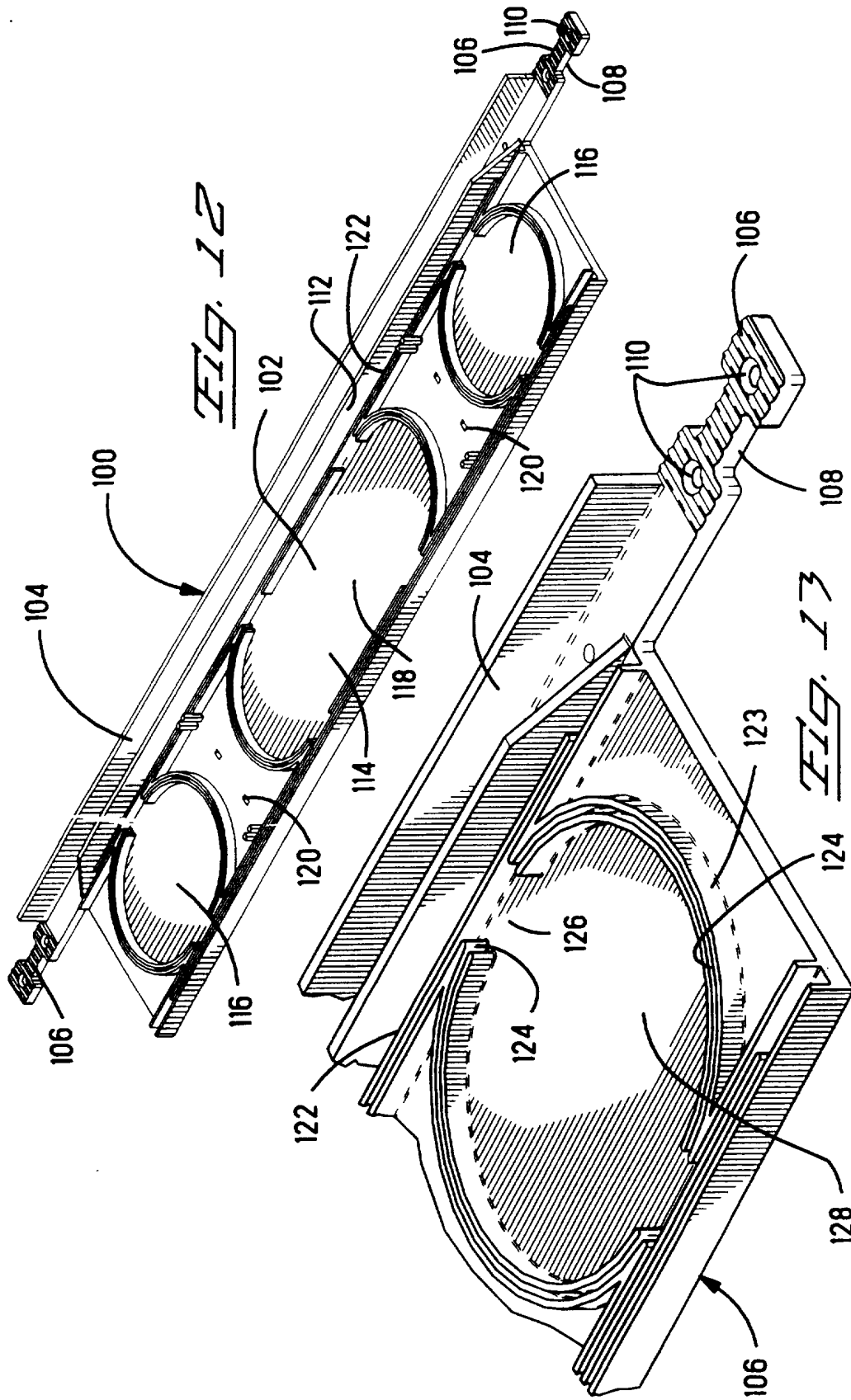
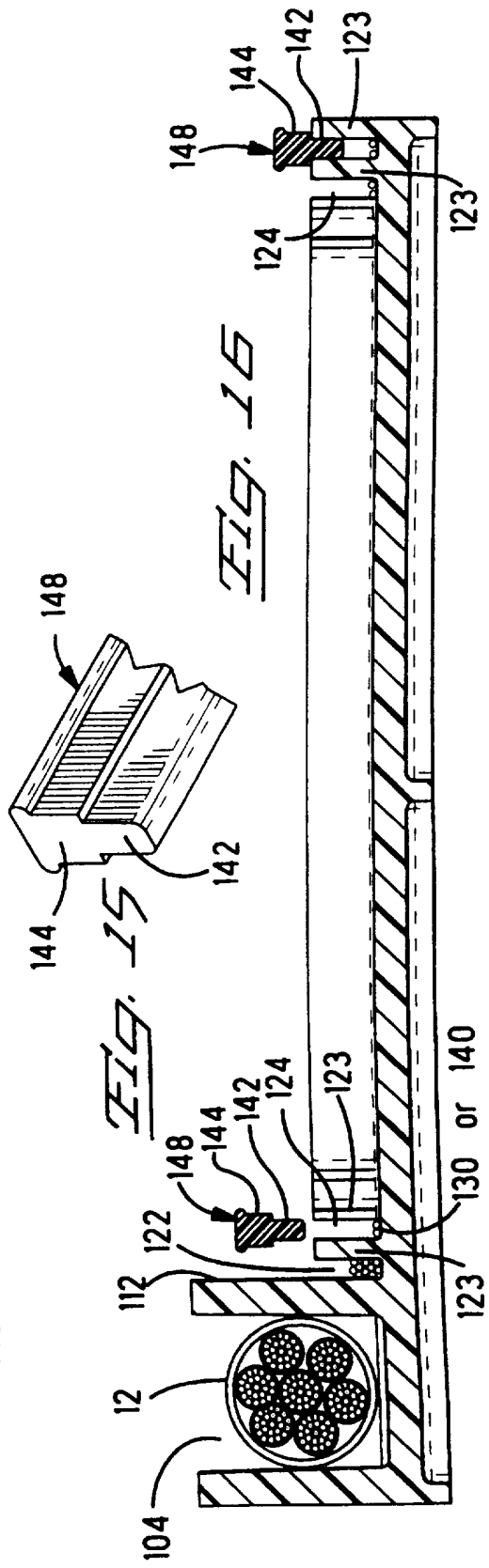
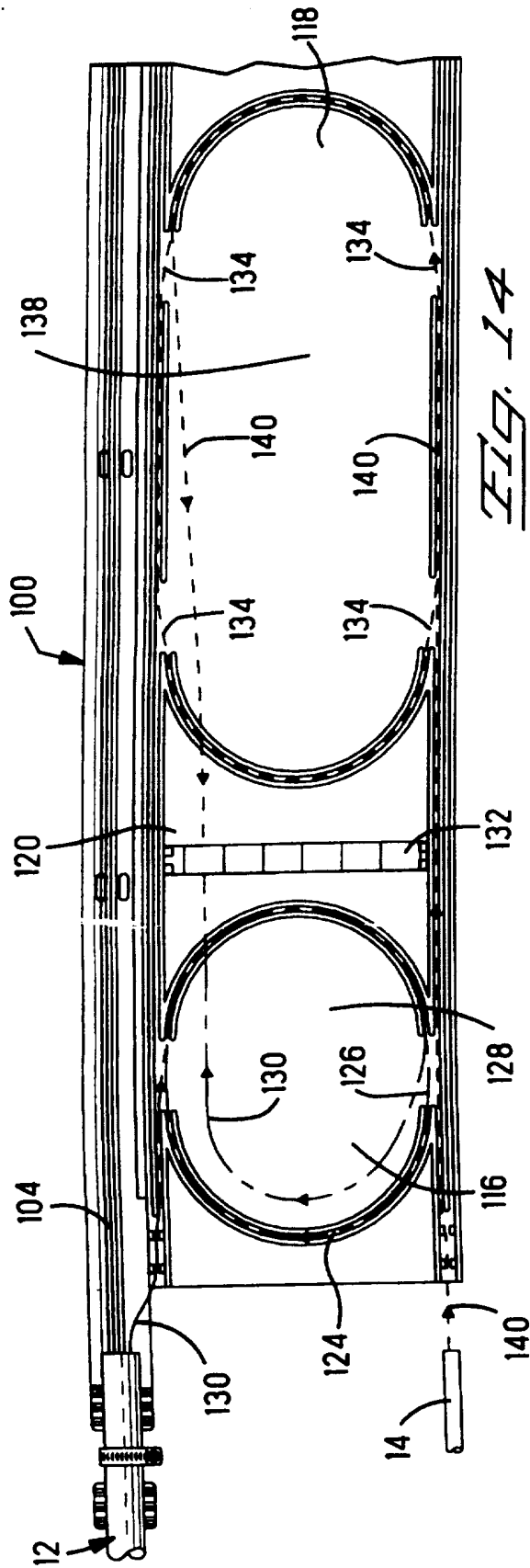

FIG. 12

FIG. 13



INTERNATIONAL SEARCH REPORT

International Application No
PCT/US 97/07096

A. CLASSIFICATION OF SUBJECT MATTER
IPC 6 G02B6/44 H02G15/013

According to International Patent Classification (IPC) or to both national classification and IPC

B. FIELDS SEARCHED

Minimum documentation searched (classification system followed by classification symbols)

IPC 6 G02B H02G

Documentation searched other than minimum documentation to the extent that such documents are included in the fields searched

Electronic data base consulted during the international search (name of data base and, where practical, search terms used)

C. DOCUMENTS CONSIDERED TO BE RELEVANT

Category *	Citation of document, with indication, where appropriate, of the relevant passages	Relevant to claim No.
Y	FR 2 723 162 A (CAB SA) 2 February 1996 see claims; figures ---	1-4
Y	DE 43 33 067 C (ROSE WALTER GMBH & CO KG) 9 March 1995 see claims; figures ---	1-4
A	US 5 280 556 A (JONES WESLEY W) 18 January 1994 see claims; figures ---	1
A	US 4 421 945 A (MOISSON MARC F) 20 December 1983 see claims; figures ---	1
	-/--	

Further documents are listed in the continuation of box C.

Patent family members are listed in annex.

- | | |
|--|---|
| <p>* Special categories of cited documents :</p> <ul style="list-style-type: none"> *A* document defining the general state of the art which is not considered to be of particular relevance *E* earlier document but published on or after the international filing date *L* document which may throw doubts on priority claim(s) or which is cited to establish the publication date of another citation or other special reason (as specified) *O* document referring to an oral disclosure, use, exhibition or other means *P* document published prior to the international filing date but later than the priority date claimed | <ul style="list-style-type: none"> *T* later document published after the international filing date or priority date and not in conflict with the application but cited to understand the principle or theory underlying the invention *X* document of particular relevance; the claimed invention cannot be considered novel or cannot be considered to involve an inventive step when the document is taken alone *Y* document of particular relevance; the claimed invention cannot be considered to involve an inventive step when the document is combined with one or more other such documents, such combination being obvious to a person skilled in the art. * & * document member of the same patent family |
|--|---|

Date of the actual completion of the international search <p style="text-align: center;">21 July 1997</p>	Date of mailing of the international search report <p style="text-align: center;">6. 08. 97</p>
--	--

Name and mailing address of the ISA European Patent Office, P.B. 5818 Patentlaan 2 NL - 2280 HV Rijswijk Tel. (+ 31-70) 340-2040, Tx. 31 651 epo nl, Fax: (+ 31-70) 340-3016	Authorized officer <p style="text-align: center;">Pfahler, R</p>
--	---

INTERNATIONAL SEARCH REPORT

Intern nal Application No
PCT/US 97/07096

C.(Continuation) DOCUMENTS CONSIDERED TO BE RELEVANT		
Category *	Citation of document, with indication, where appropriate, of the relevant passages	Relevant to claim No.
A	US 4 701 574 A (SHIMIRAK GERLAD L ET AL) 20 October 1987 cited in the application see claims; figures ---	1
A	US 4 831 215 A (CLARK GORDON P ET AL) 16 May 1989 cited in the application see claims; figures ---	1
A	EP 0 514 174 A (AMERICAN TELEPHONE & TELEGRAPH) 19 November 1992 see claims; figures -----	1,5,6

1 .

INTERNATIONAL SEARCH REPORT

Information on patent family members

International Application No
PCT/US 97/07096

Patent document cited in search report	Publication date	Patent family member(s)	Publication date
FR 2723162 A	02-02-96	NONE	
DE 4333067 C	09-03-95	EP 0645656 A	29-03-95
US 5280556 A	18-01-94	AU 659959 B	01-06-95
		AU 4730293 A	31-03-94
		CA 2104360 A,C	26-03-94
		CN 1085018 A	06-04-94
		DE 69303137 D	18-07-96
		DE 69303137 T	24-10-96
		EP 0589618 A	30-03-94
		JP 6217444 A	05-08-94
		NZ 248710 A	22-12-94
US 4421945 A	20-12-83	GB 1603626 A	25-11-81
		DE 7725372 U	02-02-78
		FR 2388432 A	17-11-78
US 4701574 A	20-10-87	CA 1258502 A	15-08-89
		EP 0191609 A	20-08-86
		JP 6067096 B	24-08-94
		JP 61247210 A	04-11-86
		BR 8600494 A	21-10-86
US 4831215 A	16-05-89	NONE	
EP 0514174 A	19-11-92	US 5155303 A	13-10-92
		CA 2068552 C	13-12-94
		DE 69215269 D	02-01-97
		DE 69215269 T	28-05-97