

W. C. DICKERSON.  
 FLAT CLOSING DRINKING CUP.  
 APPLICATION FILED MAR. 11, 1912.

1,069,236.

Patented Aug. 5, 1913.

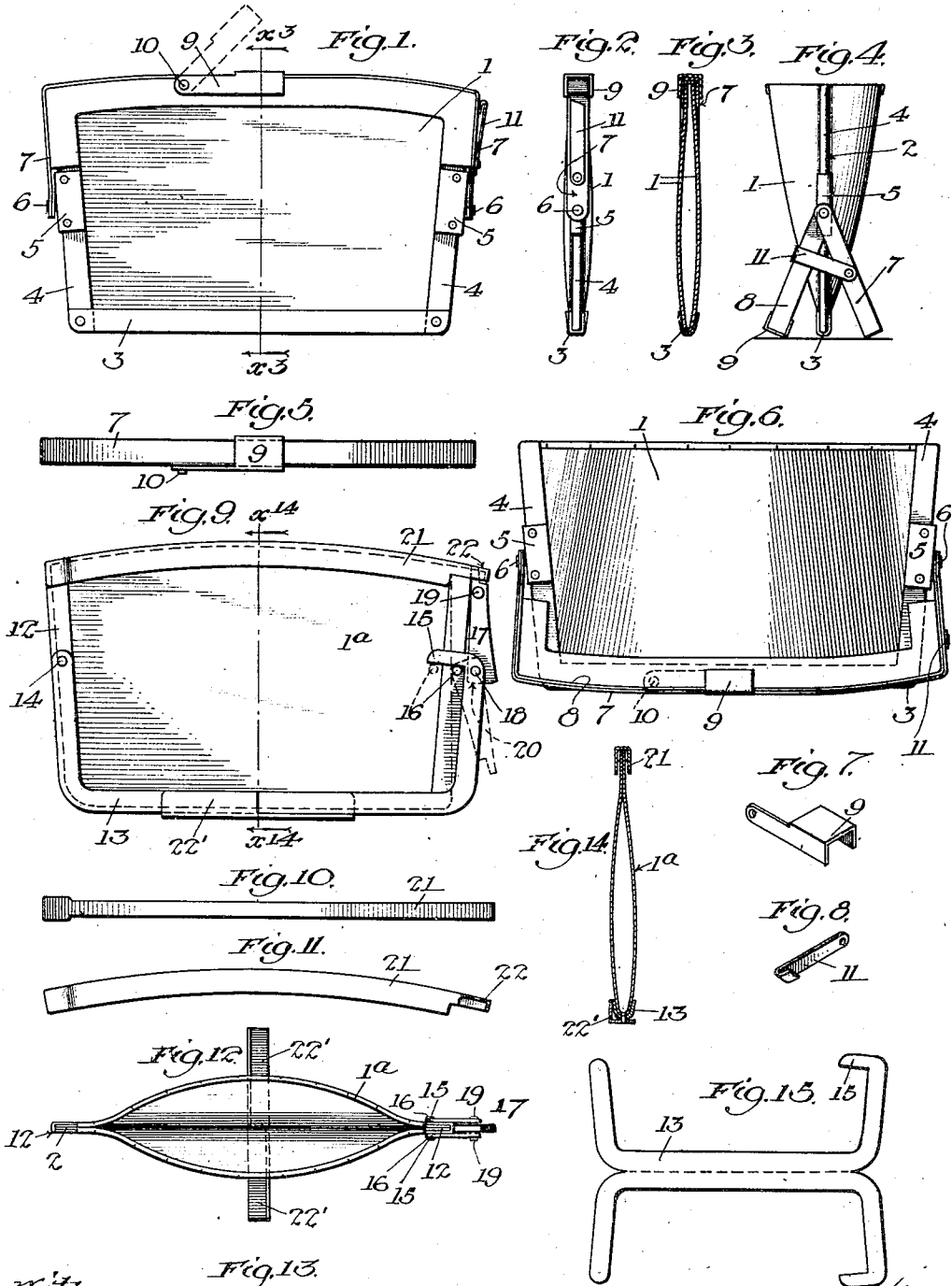

Witnesses:  
 L. A. Allen  
 Sully Russo

Inventor:  
 Warren C. Dickerson  
 by *Spencer Haerley*  
 atty.

# UNITED STATES PATENT OFFICE.

WARREN C. DICKERSON, OF LOS ANGELES, CALIFORNIA.

## FLAT-CLOSING DRINKING-CUP.

1,069,236.

Specification of Letters Patent.

Patented Aug. 5, 1913.

Application filed March 11, 1912. Serial No. 633,113.

*To all whom it may concern:*

Be it known that I, WARREN C. DICKERSON, a citizen of the United States, residing at Los Angeles, county of Los Angeles, State of California, have invented new and useful Improvements in Flat-Closing Drinking-Cups, of which the following is a specification.

This invention relates to a drinking cup which when not in use may be closed into a flat form and readily carried in the pocket or other place, and is of especial advantage to travelers.

The invention consists of a receptacle having metallic, flexible walls capable of being pressed flatly against each other to form a flat package or of being bowed apart from each other to form the necessary holding capacity.

The invention also comprises means for holding the flexible walls in expanded position.

Further features of the invention will be brought out in the following description.

Referring to the drawings: Figure 1 is a side elevation. Fig. 2 is an end elevation of the device shown in Fig. 1. Fig. 3 is a section on line  $x^2-x^3$  Fig. 1. Fig. 4 is an end view showing the cup opened and arranged in self-supporting position. Fig. 5 is a plan view. Fig. 6 is a side elevation of the device opened as in Fig. 4. Fig. 7 is a perspective of the clasp. Fig. 8 is a perspective of the hook. Fig. 9 is a side elevation of another form, showing the cup in flat position. Fig. 10 is a plan view of the cover for the form shown in Fig. 9. Fig. 11 is a side elevation partly broken away of the cover of Fig. 10. Fig. 12 is a plan view of the form shown in Fig. 9 when expanded. Fig. 13 is a perspective of the supporting foot. Fig. 14 is a section on line  $x^{14}-x^{14}$  Fig. 9. Fig. 15 is a plan view of the form of metal blank from which the spring frame of the form shown in Fig. 9 is constructed.

In the different forms shown the cup comprises a pair of metallic flexible sides which are capable of being flattened against each other to close the cup into a compact form convenient for carrying or placing in the pocket, and includes means for holding the flexible sides in expanded or open position and also means for holding them in closed position. The invention also includes means for holding the cup erect when it is

opened ready for use, enabling the cup to be rested upon any flat support.

In Fig. 1 the flexible side plates 1 are formed of a single piece of metal as shown in Fig. 3, which is folded at the bottom and the end edges 2 are folded together to form a tight seam. A channel member 3 extends along the bottom to strengthen the bottom edge, and extending up along each end edge are channel members 4 which stiffen the edges. Lugs 5 are secured to the edge members 4 and pivoted to the lugs 5 by pins 6 is an outer bail 7 and an inner bail 8; each of the bails being of angle shape in cross section and folding together when closed, as shown in Fig. 3. The plates 1 are given a natural bend so that when permitted to do so they will naturally expand into the position shown in Fig. 4, and in order to close them it is necessary to press them together against each other and swing the bails 7 and 8 into closed position and then a clasp 9 which is pivoted at 10 is swung down to hold the two bails in closed position and thus lock the cup in flat closed position. By swinging the bails 7 and 8 open as shown in Fig. 4 and engaging a hook 11 which is pivoted to the bail 7 with the bail 8, the bails 7 and 8 will act as supports for the cup and will hold it upright on any flat support.

In form shown in Fig. 9 the flexible metallic plates 1<sup>a</sup> are fitted within a U-shaped spring frame 12 which is U-shaped in cross section. A spreading frame 13 fits over the frame 12 and is pivoted thereto at 14 and has lugs 15 which extend inwardly over pins 16 projecting from each side of one arm of the frame 12. A cam arm 17 is pivoted at 18 to the spreading frame 13 and has knobs 19 enabling it to be easily operated and swung into the position shown in dotted lines in Fig. 9, during which action its cam face 20 bears against the edge of the frame 12 and springs the arms of frame 12 toward each other, causing the plates 1<sup>a</sup> to be bowed outwardly into the position shown in Fig. 12. During this action the pins 16 ride along under the lugs 15. A cover 21 is arranged to fit over the upper edge of this form of cup when it is closed, the cover having an extension 22 which fits over the upper end of the arm 17 so that when the cover is in position it is impossible to operate the arm 17. This is important because if the arm 17 were to be

swung around into dotted line position when the cover 21 is on, the plates 1<sup>a</sup> being prevented from spreading out and the frame 12 being collapsed would result in damage, which is obviated by the construction described. A foot 22' is pivoted to the frame 13 and when the cup is opened the foot 22' may be swung into a right angle position, as shown in Fig. 12 to support the cup.

10 What I claim is:—

1. A flat closing cup comprising two flexible plates secured at their bottom and side edges, a U-shaped frame extending along the bottom and side edges of the plates, a spreading frame extending along the bottom and sides of the first frame, a lever pivoted to the spreading frame and bearing against the first frame for contracting the first frame to spread the plates apart.

20 2. A flat closing cup comprising two flexible plates secured at their bottom and side edges, a U-shaped frame extending along the bottom and side edges of the plates, a spreading frame extending along the bottom and sides of the first frame, a lever pivoted to the spreading frame and bearing against the first frame for contracting the first frame to spread the plates apart, and a grooved cover fitting over the upper edges of the two plates.

30 3. A flat closing cup comprising two flexible plates secured at their bottom and side edges, a U-shaped frame extending along the bottom and side edges of the plates, a spreading frame extending along the bottom and sides of the first frame, a lever pivoted to the spreading frame and bearing against the first frame for contracting the first frame to spread the plates apart, and a grooved cover fitting over the upper edges of the two plates, the end of the cover projecting beyond the plates and receiving the

end of said lever to lock said lever against clamping movement when the cover is on.

4. A flat closing cup comprising two flexible metallic plates secured at their bottom and side edges, a metallic spring frame along the bottom and side edges of the plates normally holding said plates flat, and means for contracting said frame and locking the frame in contracted position to hold the plates in bowed position.

5. A flat closing cup comprising two flexible plates secured at their bottom and side edges, a U-shaped frame extending along the bottom and side edges of the plates, a spreading frame extending along the bottom and sides of the first frame, a lever pivoted to the spreading frame and bearing against the first frame for contracting the first frame to spread the plates apart, and pins projecting from a side member of the first frame, said spreading frame having lugs which extend over said pins and slidably rest thereon.

6. A flat closing cup comprising two flexible metallic plates secured at their bottom and side edges; a metallic spring frame along the bottom and side edges of the plates normally holding said plates flat, and means for contracting said frame and locking the frame in contracted position to hold the plates in bowed position, and a supporting member pivoted at the bottom of the spreading frame and adapted to be swung into a transverse position to support the cup.

In testimony whereof, I have hereunto set my hand at Los Angeles, California, this 2d day of March 1912.

WARREN C. DICKERSON.

In presence of—

G. T. HACKLEY,  
GLADYS RUSSELL.