

(19) World Intellectual Property Organization
International Bureau



(43) International Publication Date
18 May 2007 (18.05.2007)

PCT

(10) International Publication Number
WO 2007/055432 A1

(51) International Patent Classification:
D01F 1/02 (2006.01)

(21) International Application Number:
PCT/KR2005/003857

(22) International Filing Date:
14 November 2005 (14.11.2005)

(25) Filing Language: Korean

(26) Publication Language: English

(71) Applicant (for all designated States except US): **SE DA COPERATION CO., LTD.** [KR/KR]; 362-6, Samrag-Dong, Sasang-Gu, Busan 617-825 (KR).

(72) Inventor; and

(75) Inventor/Applicant (for US only): **LEE, Jong-Hoi** [KR/KR]; Byugsan Apt. 101-109, 616-4 Jurye-3Dong, Sasang-Gu, Busan 617-838 (KR).

(74) Agent: **LEE, Joong-Seop**; Lawin Tower 301, 1497-1, Geoje-1Dong, Yeonje-Gu, Busan 611-071 (KR).

(81) Designated States (unless otherwise indicated, for every kind of national protection available): AE, AG, AL, AM, AT, AU, AZ, BA, BB, BG, BR, BW, BY, BZ, CA, CH, CN, CO, CR, CU, CZ, DE, DK, DM, DZ, EC, EE, EG, ES, FI, GB, GD, GE, GH, GM, HR, HU, ID, IL, IN, IS, JP, KE, KG, KM, KN, KP, KZ, LC, LK, LR, LS, LT, LU, LV, LY, MA, MD, MG, MK, MN, MW, MX, MZ, NA, NG, NI, NO, NZ, OM, PG, PH, PL, PT, RO, RU, SC, SD, SE, SG, SK, SL, SM, SY, TJ, TM, TN, TR, TT, TZ, UA, UG, US, UZ, VC, VN, YU, ZA, ZM, ZW.

(84) Designated States (unless otherwise indicated, for every kind of regional protection available): ARIPO (BW, GH, GM, KE, LS, MW, MZ, NA, SD, SL, SZ, TZ, UG, ZM, ZW), Eurasian (AM, AZ, BY, KG, KZ, MD, RU, TJ, TM), European (AT, BE, BG, CH, CY, CZ, DE, DK, EE, ES, FI, FR, GB, GR, HU, IE, IS, IT, LT, LU, LV, MC, NL, PL, PT, RO, SE, SI, SK, TR), OAPI (BF, BJ, CF, CG, CI, CM, GA, GN, GQ, GW, ML, MR, NE, SN, TD, TG).

Published:
— with international search report

For two-letter codes and other abbreviations, refer to the "Guidance Notes on Codes and Abbreviations" appearing at the beginning of each regular issue of the PCT Gazette.

(54) Title: YARN AND MANUFACTURE METHOD THEREOF

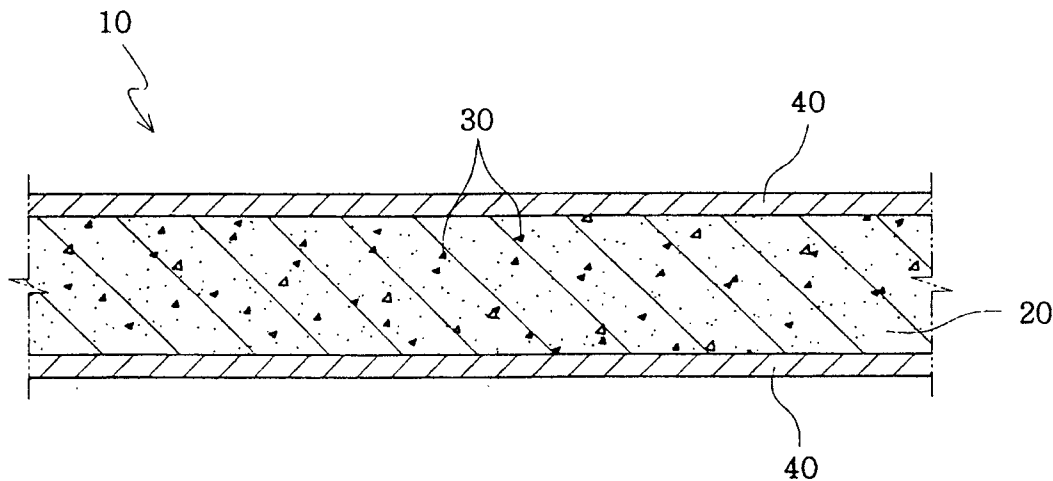

(57) Abstract: A yarn containing a functional powder and having a coating layer formed on its outer diameter, and a manufacture method thereof, and woven fabrics and textile articles obtained from the yarn are provided.



WO 2007/055432 A1

YARN AND MANUFACTURE METHOD THEREOF**Technical Field**

5 The present invention relates to a yarn, and more particularly, to a yarn containing a functional powder such as Tourmaline or Monazite and having a coating layer formed on its outer diameter, and a manufacture method thereof, and woven fabrics and textile articles obtained from the yarn.

10 Background Art

As well known in the art, Tourmaline belonging to a hexagonal system refers to a mineral being a kind of an igneous rock, naturally generating positive and negative polarities at both ends of a crystal, and having a property
15 of generating a potential difference of one million volts and generating a permanent weak current. The Tourmaline has a rigidity of 7.0 to 7.5, and has a specific gravity of 2.98 to 3.20. The Tourmaline has a chemical component of borosilicate being a complex of iron, magnesium, alkali
20 metal, and aluminum, and is a kind of a healthy precious stone such as a uranium ore and a magnetite, for storing energy of itself and endlessly emitting the energy, thereby energizing a human body.

As effects of the Tourmaline, it is known that, due to
25 its weak heat, particles generate electricity, and a weak current flows to be in association with a body heat, thereby transmitting and keeping the heat, and an acupuncture point is stimulated and a peripheral circulating system is improved, thereby facilitating a blood flow, and anions are
30 generated, thereby providing effects of anti-bacteria, deodorization, and cleaning. The Tourmaline has an effect of an electrostatic potential therapy such as improvement of physical constitution and cleaning of blood, due to cell activation.

35 In particular, far infrared rays and the anions emitting from the Tourmaline result in an operation and

effect of alleviation of neuralgia, arthritis, and backache, glycosuria, constipation-ache, deodorization, anti-bacteria, dehumidification, softening of water, and air cleaning, thereby being in trend of gradually spreading for use in a construction field, an environment field, and a medical field.

Meantime, the Monazite belonging to a monoclinic system is a phosphate mineral of a cerium group rare earth element, has a rigidity of 5 to 5.5 and a specific gravity of 4.6 to 5.4, and generates a large amount of anions and far infrared rays.

Disclosure

Technical Problem

Accordingly, the present invention is directed to a yarn and a manufacture method thereof that substantially obviate one or more of the problems due to limitations and disadvantages of the related art.

An object of the present invention is to provide a yarn that contains a functional powder obtained by pulverizing Tourmaline or Monazite, and is a material of fabrics used for a variety of textile articles.

Another object of the present invention is to provide a yarn that contains a functional powder, and has a coating layer formed on its outer diameter, thereby preventing the functional powder from being broken off.

A further another object of the present invention is to provide a yarn that contains a functional powder, and is of the same material as a coating layer, thereby enhancing adhesiveness between the yarn and the coating layer.

Technical Solution

To achieve these and other advantages and in accordance with the purpose of the present invention, as embodied and broadly described, there is provided a yarn containing a functional powder, wherein a coating layer is formed on an

outer diameter of a core yarn mixed with the functional powder.

The functional powder may be any one of Tourmaline or Monazite.

5 The coating layer may be of the same material as the core yarn.

10 In another aspect of the present invention, there is provided a method for manufacturing a yarn containing a functional powder, the method including the steps of: melting polyester; providing a mixture of the functional powder finely pulverized with the melted polyester; and extruding the mixture and forming a core yarn and at the same time, forming a coating layer on an outer diameter of the formed core yarn.

15 Fabrics to be designated in the present invention is obtained by intersecting and weaving the yarns named as a weft and a warp, and textile articles are products obtained from the woven fabrics, and can be exemplified as clothes or bedclothes.

20 Meantime, the functional power to be designated in the present invention refers to material capable of emitting substance good to a human body such as far infrared rays and anions in great quantities. As the functional powder used in the present invention, any one selected from the group
25 consisting of Tourmaline and Monazite is pulverized and used in a powder form.

Advantageous Effects

30 First, the present invention has an effect in that a yarn being material of fabrics used for a variety of textile articles contains a functional powder emitting far infrared rays and anions, thereby providing textile articles good to a human body.

35 Second, the present invention has an effect in that a coating layer is formed on an outer diameter of the yarn to prevent the functional powder contained in the yarn from

being broken off from the yarn, thereby maintaining the far infrared rays and the anions to be emitted from the functional powder for a longer time.

Third, the present invention has an effect in that the coating layer and the yarn employ the polyester being the same material, thereby enhancing the adhesiveness between the yarn and the coating layer.

Description of Drawings

FIG. 1 illustrates a yarn containing a functional powder according to the first embodiment of the present invention;

FIG. 2 illustrates a structure of an extruder for extruding the yarn containing the functional powder of FIG. 1;

FIG. 3 illustrates woven fabrics obtained from the yarn of FIG. 1;

FIG. 4 illustrates clothes being textile articles obtained from the fabrics of FIG. 3; and

FIG. 5 illustrates a yarn containing a functional powder according to the second embodiment of the present invention.

Best Mode for Carrying out the Invention

Hereinafter, preferred embodiments of the present invention will be described in detail with reference to accompanying drawings.

FIG. 1 illustrates a yarn containing a Tourmaline powder being a functional powder according to the first embodiment of the present invention.

As shown in FIG. 1, the yarn 10 containing the Tourmaline powder includes a core yarn 20, and a coating layer 40 coated on an outer diameter of the core yarn 20.

The core yarn 20 corresponds to a center of the yarn 10, and is formed by melting and extruding polyester being a synthetic resin material. It is desirable that the melted

core yarn 20 is mixed with the Tourmaline powder 30 and is extruded together with the Tourmaline powder 30, thereby forming the core yarn 20.

5 The coating layer 40 is a layer for coating and sealing the outer diameter of the core yarn 20 so that the Tourmaline powder 30 mixed with the core yarn 20 is not separated and broken out from the core yarn 20 in course of use. In other words, the Tourmaline powder 30 can be kept for a long time within the core yarn 20 by the coating layer 40, so that the
10 core yarn 10 can show for a long time a functionality of the Tourmaline powder 30. The coating layer 40 preferably employs polyester that is the same material as the core yarn 20. This is to prevent adhesiveness between the coating layer 40 and the core yarn 20 from being deteriorated due to
15 use of different materials.

FIG. 2 illustrates a structure of an extruder 50 for extruding the yarn 10 containing the functional powder of FIG. 1.

20 The extruder 50 includes an inner tube 60, and an outer tube 70 fitted on a circumference surface of the inner tube 60, and is preferably constructed to form a space part 80 as much as a predetermined size between the inner tube 60 and the outer tube 70.

25 In the above constructed extruder 50, the polyester 20a of a gel state mixed with the Tourmaline powder 30 and being the material of the core yarn 20 is inputted into and extruded from the inner tube 60 at a high pressure. A coating liquid 40a being a raw material of the coating layer 40 coated on the outer diameter of the core yarn 20 is
30 inputted at a high pressure into the space part 80 provided between the inner and outer diameters 60 and 70, and then is coated on the outer diameter of the polyester 20a under extrusion. As a result, as shown in FIG. 1, the yarn 10 having the coating layer 40 formed on the outer diameter of
35 the core yarn 20 mixed with the Tourmaline powder 30 is manufactured. Hereinafter, a method for manufacturing the

yarn 10 containing the Tourmaline powder using the extruder 50 will be described in detail.

5 First, the polyester 20a being the raw material of the core yarn 20 is melted to be in the gel state at a predetermined temperature.

10 After that, the Tourmaline powder 30 pulverized to have a predetermined size, preferably, a size of 0.05 μm to 0.15 μm using a pulverizing device is mixed and uniformly agitated with the melted polyester 20a, and then is manufactured in a chip form. The Tourmaline powder 30 preferably employs a powder made in Brazil emitting anions of about 400 to 2000 in number.

15 In a melted state of a mixture manufactured in the chip form, that is, the polyester 20a mixed with the Tourmaline powder 30, the polyester 20a passes (is extruded) into the inner tube 60 of the extruder 50 and at the same time, the coating liquid 40a being the raw material of the coating layer 40 is inputted into the space part 80 provided between the inner and outer diameters 60 and 70 of the extruder 50.

20 After that, the polyester 20a mixed with the Tourmaline powder 30 passing through the inner tube 60 is extruded and formed as the core yarn 20, and the coating liquid 40a inputted into the space part 80 between the inner and outer tubes 60 and 70 of the extruder 50 is coated on the outer diameter of the formed core yarn 20, thereby forming the coating layer 40 on the outer diameter of the core yarn 20.

25 Next, the core yarn 20 having the coating layer 40 is dried for a predetermined time and, if so, the yarn 20 containing the Tourmaline powder is manufactured as shown in FIG. 1.

30 FIG. 3 illustrates woven fabrics 100 obtained from the yarn of FIG. 1, and FIG. 4 illustrates clothes 200 being textile articles obtained from the fabrics 100 of FIG. 3.

35 As shown in FIGS. 3 and 4, the clothes 200 obtained from the woven fabrics 100 that is obtained from the yarn 10 containing the Tourmaline powder can have the functionality

such as deodorization, anti-bacteria, and dehumidification and in addition, can show various effects of the Tourmaline powder 30.

5 Meantime, the present invention typically provides a description in which the woven fabrics 100 obtained from the yarn 10 containing the Tourmaline powder is associated with the clothes, but in addition to the clothes, the inventive fabrics can be associated with and used for even other all textile articles (for example, sheet, cushion or pillow).

10 <Second Embodiment>

FIG. 5 illustrates a yarn containing a Monazite powder being a functional powder according to the second embodiment of the present invention.

15 As shown in FIG. 5, the yarn 310 containing the Monazite powder has the same construction as the yarn 10 according to the first embodiment of the present invention, that is, the yarn 310 includes a core yarn 320 formed by melting and extruding polyester being a synthetic resin, and a coating layer 340 that is of the same material as the core yarn 320 and coated on an outer diameter of the core yarn 320. The yarn 310 is characterized by mixing the Monazite powder 330, instead of the Tourmaline powder, with the core yarn 320.

20
25 Meantime, the yarn 310 containing the Monazite powder is manufactured in the same method as the manufacture method of the first embodiment of the present invention. The woven fabrics of FIG. 3 of the first embodiment are obtained from the above manufactured yarn 310, and the clothes of FIG. 4 of the first embodiment are obtained from the woven fabrics.

30 **Industrial Applicability**

As described above, the present invention achieves many effects as follows.

35 First, the present invention has an effect in that the yarn being the material of the fabrics used for a variety of

the textile articles contains the functional powder emitting far infrared rays and anions, thereby providing the textile articles good to a human body.

5 Second, the present invention has an effect in that the coating layer is formed on the outer diameter of the yarn to prevent the functional powder contained in the yarn from being broken off from the yarn, thereby maintaining the far infrared rays and the anions to be emitted from the functional powder for a longer time.

10 Third, the present invention has an effect in that the coating layer and the yarn employ the polyester being the same material, thereby enhancing the adhesiveness between the yarn and the coating layer.

15 While the present invention has been described and illustrated herein with reference to the preferred embodiments thereof, it will be apparent to those skilled in the art that various modifications and variations can be made therein without departing from the spirit and scope of the invention. Thus, it is intended that the present invention
20 covers the modifications and variations of this invention that come within the scope of the appended claims and their equivalents.

Claims

1. A yarn containing a functional powder,
wherein a coating layer is formed on an outer diameter
5 of a core yarn mixed with the functional powder.

2. The yarn according to claim 1, wherein the
functional powder is any one of Tourmaline or Monazite.

10 3. The yarn according to claim 1 or 2, wherein the
coating layer is of the same material as the core yarn.

4. A woven fabrics obtained from a yarn claimed in
claim 3.

15 5. A textile articles obtained from a woven fabrics
claimed in claim 4.

6. A method for manufacturing a yarn containing a
20 functional powder, the method comprising the steps of:
melting polyester;
providing a mixture of the functional powder finely
pulverized with the melted polyester; and
extruding the mixture and forming a core yarn and at
25 the same time, forming a coating layer on an outer diameter
of the formed core yarn.

Fig 1

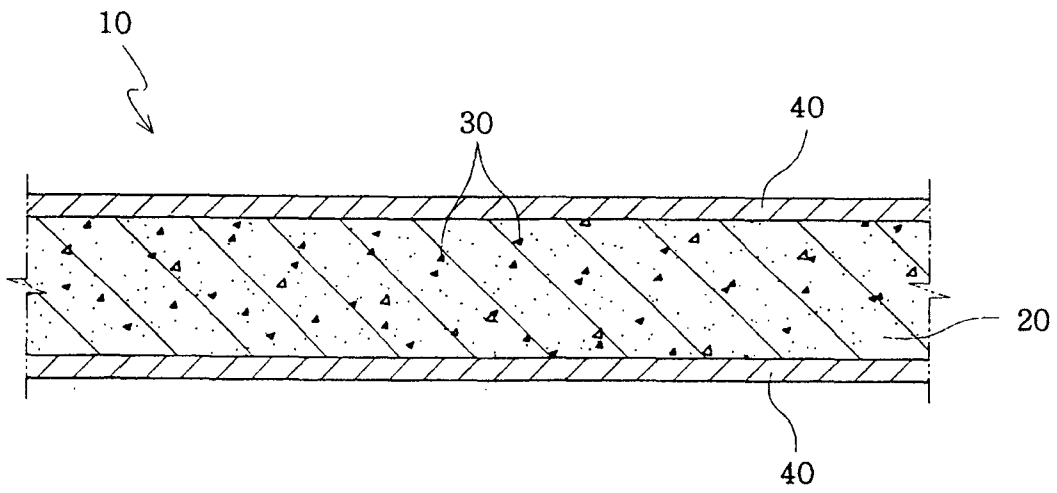

Fig 2

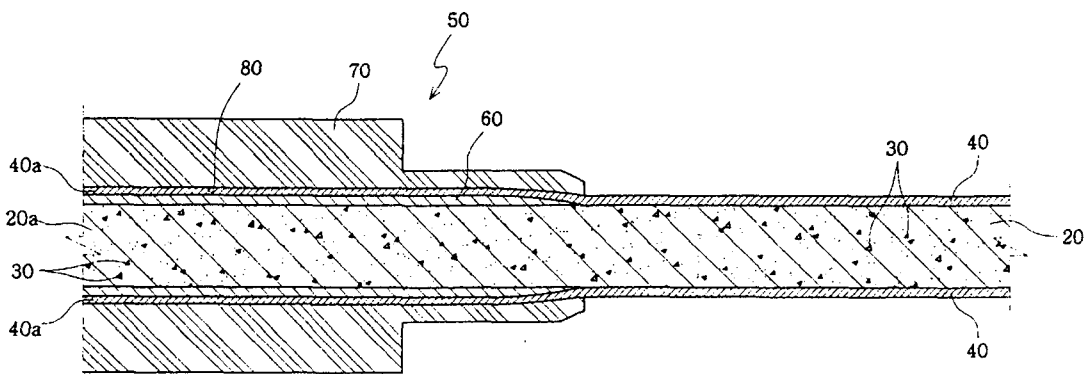
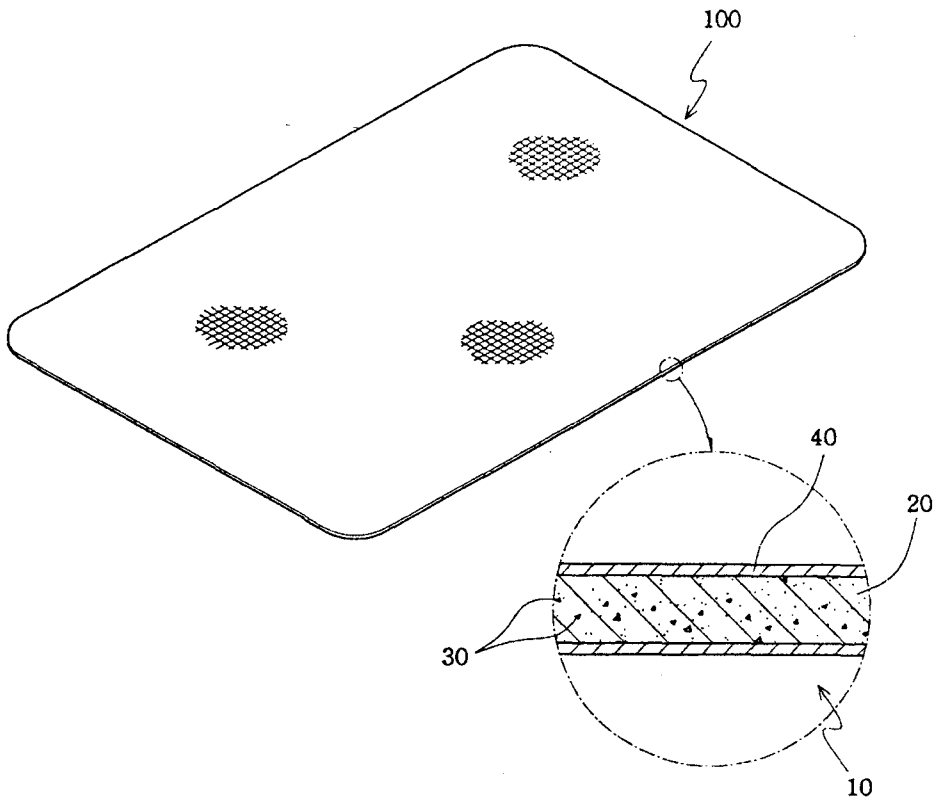

Fig 3



3/4

Fig 4

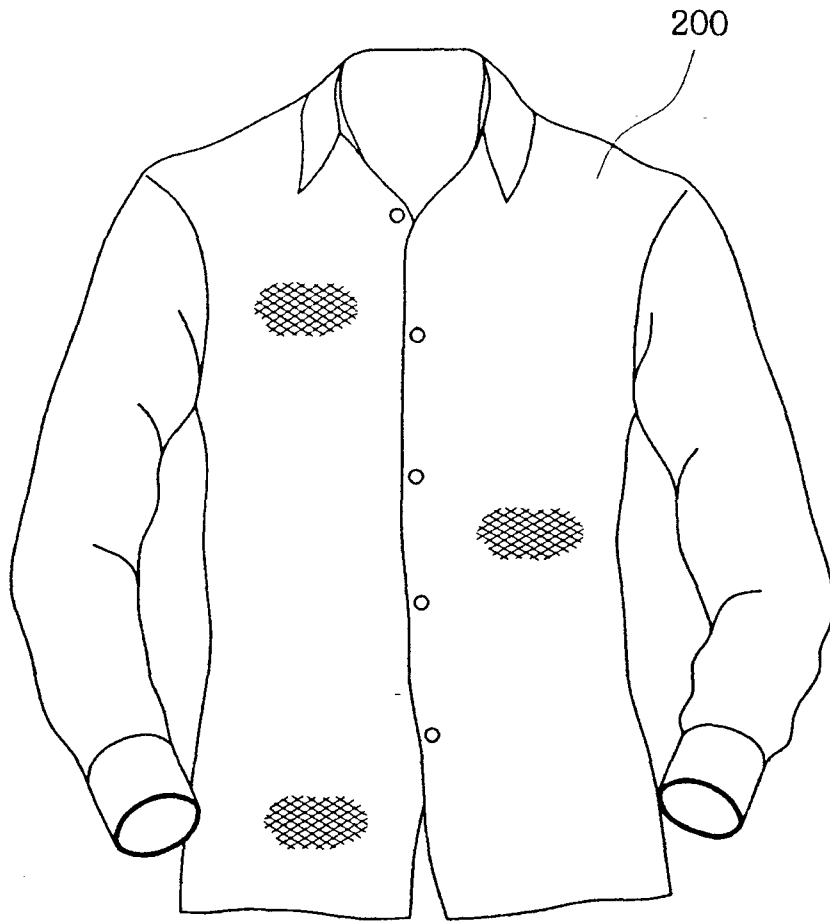
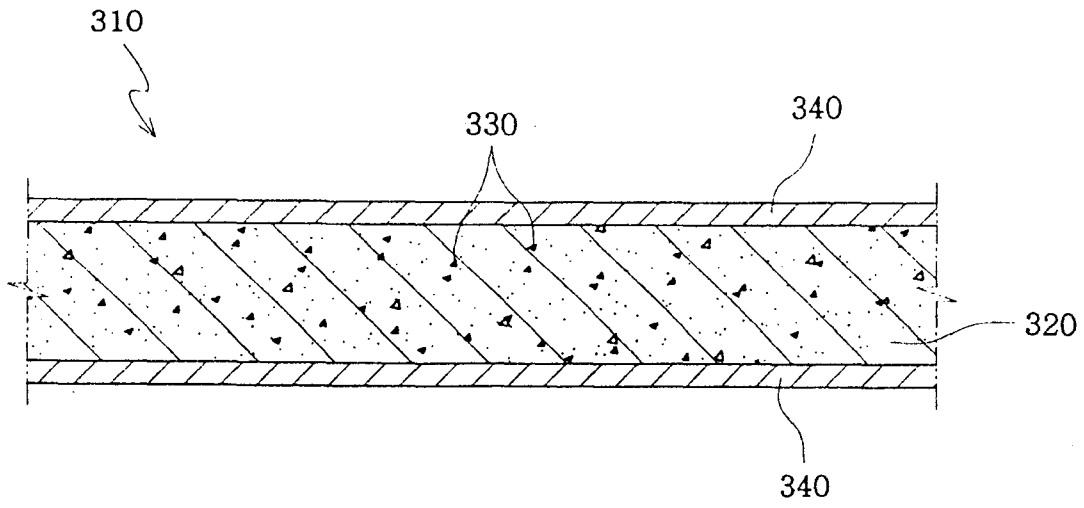

Fig 5



INTERNATIONAL SEARCH REPORT

International application No.
PCT/KR2005/003857**A. CLASSIFICATION OF SUBJECT MATTER*****D01F 1/02(2006.01)i***

According to International Patent Classification (IPC) or to both national classification and IPC

B. FIELDS SEARCHED

Minimum documentation searched (classification system followed by classification symbols)

IPC8 D01F

Documentation searched other than minimum documentation to the extent that such documents are included in the fields searched

KR, JP : IPC as above

Electronic data base consulted during the international search (name of data base and, where practicable, search terms used)

C. DOCUMENTS CONSIDERED TO BE RELEVANT

Category*	Citation of document, with indication, where appropriate, of the relevant passages	Relevant to claim No.
A	JP 2004-124269 A (UNITICA FIBERS LTD) 22 April 2004 (22.04.2004) see the claims and abstract	1-6
A	JP 2001-192927 A (BENE CORP: KK) 17 July 2001 (17.07.2001) see the claims and abstract	1-6
A	JP 06-228808 A (KUBO GIJUTSU JIMUSHO: KK) 16 August 1994 (16.08.1994) see the claims and abstract	1-6
A	KR 2005-97855 A (HYOSUNG CORP) 10 October 2005 (10.10.2005) see the claims	1-6

 Further documents are listed in the continuation of Box C. See patent family annex.

* Special categories of cited documents:

"A" document defining the general state of the art which is not considered to be of particular relevance

"E" earlier application or patent but published on or after the international filing date

"L" document which may throw doubts on priority claim(s) or which is cited to establish the publication date of citation or other special reason (as specified)

"O" document referring to an oral disclosure, use, exhibition or other means

"P" document published prior to the international filing date but later than the priority date claimed

"T" later document published after the international filing date or priority date and not in conflict with the application but cited to understand the principle or theory underlying the invention

"X" document of particular relevance; the claimed invention cannot be considered novel or cannot be considered to involve an inventive step when the document is taken alone

"Y" document of particular relevance; the claimed invention cannot be considered to involve an inventive step when the document is combined with one or more other such documents, such combination being obvious to a person skilled in the art

"&" document member of the same patent family

Date of the actual completion of the international search

19 JULY 2006 (19.07.2006)

Date of mailing of the international search report

19 JULY 2006 (19.07.2006)

Name and mailing address of the ISA/KR

Korean Intellectual Property Office
920 Dunsan-dong, Seo-gu, Daejeon 302-701,
Republic of Korea

Facsimile No. 82-42-472-7140

Authorized officer

OH, SANG KYUN

Telephone No. 82-42-481-8165



INTERNATIONAL SEARCH REPORT

Information on patent family members

International application No.

PCT/KR2005/003857

Patent document cited in search report	Publication date	Patent family member(s)	Publication date
JP 2004-124269 A	22.04.2004	Family None	
JP 2001-192927 A	17.07.2001	Family None	
JP 06-228808 A	16.08.1994	Family None	
KR 2005-97855 A	10.10.2005	Family None	