



(72) **TEBBY, STEPHEN WALKER, GB**

(71) **CONCENTRIC PUMPS LIMITED, GB**

(51) Int.Cl.⁶ F01P 5/10, F01P 5/12

(30) 1998/09/03 (9819261.0) GB

(54) **AMELIORATIONS APPORTEES AUX POMPES ROTATIVES**

(54) **IMPROVEMENTS TO ROTARY PUMPS**

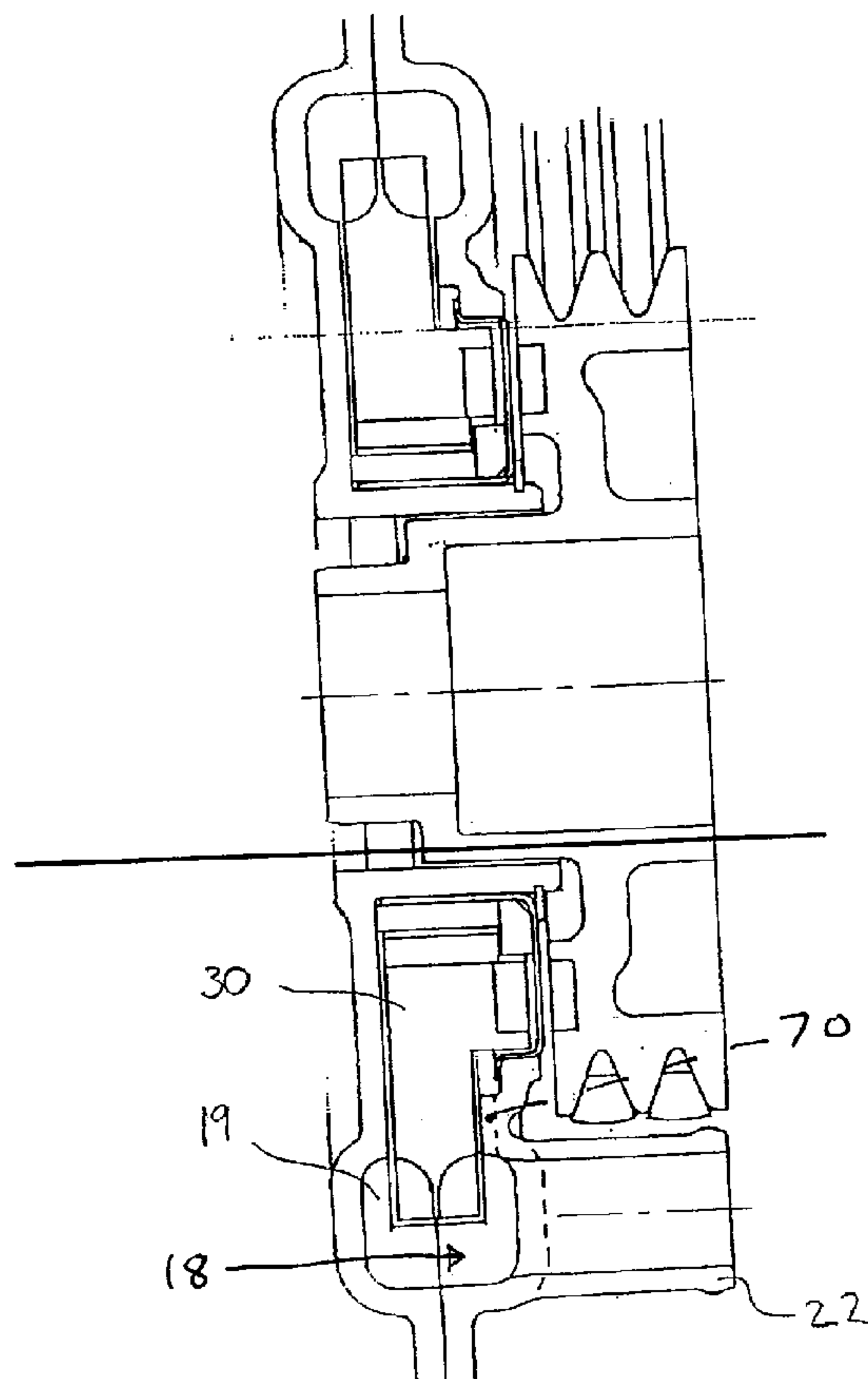

(57) A coolant pump for an I.C. engine comprises a pump cavity housing an impeller rotatable about an axis, the impeller axis being located coaxially with the rotational axis of the crankshaft of the engine.

IMPROVEMENTS TO ROTARY PUMPS

Abstract

A coolant pump for an I.C. engine comprises a pump cavity housing an impeller rotatable about an axis, the impeller axis being located coaxially with the rotational axis of the crankshaft of the engine.

IMPROVEMENTS TO ROTARY PUMPS

This invention relates to coolant pumps for internal combustion engines.

It is well known that a substantial proportion of the power output of an I.C. engine is utilised in driving engine auxiliaries, and over the past decades of development of the I.C. engine many such auxiliaries such as coolant pumps, lubricant pumps and coolant fans have been developed to be so driven. The location of these auxiliary components adjacent the crankshaft in known engine designs, creates a high demand for space within the engine compartment. It is an object of the invention to provide an axially compact design of pump, for example locating the cooling pump remote from the multi-positional requirements of the belt driven cooling fan for the engine. By removing the known coaxial arrangement of a cooling fan and coolant pump, greater positional flexibility is provided for the cooling fan drive. Some internal combustion engine configurations require three positions of fan drive and therefore three separate coolant pump designs, which requirements have associated production complications in terms of different coolant pump volute shapes, bolting patterns, complexity of inlet pipes and hoses, bypass

configurations, and thermostat arrangements for example. An object of the invention is therefore to mitigate or overcome at least some of these problems.

In addition, known coolant pumps suffer from the well known problems of leakage in relation to the mechanical seal necessarily employed where the drive shaft enters the pump cavity. Whilst sealless pumps have been proposed utilising a magnetic coupling drive, none has yet achieved widespread acceptance in the industry. Another object of the invention is to provide a satisfactory magnetic coupling drive coolant pump. A yet further object is to provide a lower level pump with improved cavitation resistance than in the known art.

According to a first aspect of the invention, a coolant pump for an I.C. engine comprises a pump cavity housing an impeller rotatable about an axis, the impeller axis being located coaxially with the rotational axis of the crankshaft of the engine.

Such a location simplifies drive which may be either direct or geared to the crankshaft without requiring the conventional belt drive as is necessary when the pump axis is parallel to the crankshaft but at a remote location.

However, since further auxiliaries may require to be driven from the crankshaft at the same end of the engine, it is presently preferred to provide a crankshaft mounted drive pulley for a belt drive system, and drive the coolant pump from that pulley (but not from that belt).

Preferably, the pump is driven by magnetic coupling using a first set of driving magnets in a face of the pulley and a second set of driven magnets, or torque ring, in the corresponding and adjacent impeller face, with a containment shell located between the two sets. The purpose of the shell is to contain the coolant within the pump but permit magnetic flux to couple two sets.

The crankshaft location reduces power requirement because of the more efficient coolant flow paths possible from what is essentially a low level location relative to the cooled areas of the engine. Power consumption may be reduced because of reduced cavitation in such a location. The pump can be a regenerative or peripheral type, or a centrifugal type.

According to another aspect of the invention, a coolant pump for an I.C. engine is characterised by the use of a regenerative impeller located in a peripherally discontinuous pump cavity.

The impeller may comprise a disc formed with radial flutes extending to its periphery and on both faces of the disc, which fluted marginal zone lies in the pump cavity. The cavity formed between two co-operating components of the pump body provides a substantial clearance about the fluted marginal zone only around the major portion of the impeller disc, typically 330° or thereabouts, but provides a suitable running clearance over the face areas of the disc radially inwardly of the fluted marginal zone and over the remaining 30° or thereabouts of the marginal zone.

The cavity connects to inlet and outlet ports at opposite ends of the substantial clearance portion, that is to say at opposite sides of the minimum clearance portion at the periphery. The effect then is that as the disc rotates, the flutes create a current which draws coolant in at one port and expels it out of the other port.

The close juxtaposition of the inlet and output ports may be found particularly convenient in design of coolant circuits. In addition, such a regenerative impeller system may give a pump head which is substantially higher than available with a conventional centrifugal action coolant pump having central inlet and tangential discharge thus obviating the need to rotate the impeller at a speed significantly greater than the crankshaft speed.

According to another aspect of the invention, a magnetic coupling driven regenerative impeller coolant pump has a balance port extending between a generally peripherally extending pumping cavity and the radially inward zone within the pump to encourage pressurised flow of coolant through the pump as lubricant for bearings journalling the pump impeller.

A further aspect of the invention provides a coolant pump for an I.C. engine comprising a pump body housing a cavity and an impeller within the cavity, wherein part of the body is formed by the timing case cover adjacent the crankshaft. Beneficially, the pump body is in part integral with the timing case cover. Another aspect of the invention provides a pump for an internal combustion engine having a magnetically driven impeller, which impeller is rotatable peripherally about the crankshaft of the engine.

The invention also provides that any one of the features of the invention described above or in the following description, may be combined with any other feature, and/or aspect of the invention.

The invention is now further described with reference to the accompanying drawing wherein

Figure 1 is a fragmentary front elevation of a pump according to the invention;

Figure 2 is a sectional side elevation;

Figure 3 is an even more fragmentary view similar to Figure 2 but on an enlarged scale; and

Figure 4 is an end view of part of disc 30 shown in Figures 2 and 3.

Turning first to Figure 3, the pump body comprises first component 10 which may be a portion of a timing case mounted on the front end of the engine block and surrounding the crankshaft. The centre-line or rotational axis of the crankshaft is indicated by the line 12. The pump body is completed by a second component or cover 14 which extends over an annular zone towards the outer periphery of the part 10 but not over the zone closer to the axis 12. The parts 10, 14 are, preferably, sealed permanently together along the mating faces indicated by the arrow 16 and define a pumping chamber or cavity 18 therebetween which extends over a substantial portion of the circumference of the parts 10, 14.

Turning next to Figure 1, cavity 18 is indicated in part by the broken lines extending in an arc up to and terminating at port 20 which is formed in a stub tube 22 as also shown in Figure 3. A similar port 24 in a second stub tube 26 is located at the opposite end (clockwise from the first end in this example) of the pump cavity 18. The area between the two ports 20, 24 is not provided with a cavity 18 but is closed off by a web 19 apertured to provide only a close clearance around the periphery of the impeller.

The impeller comprises a generally disc-like part 30, see Figure 3, provided with a complete ring of regularly pitched flutes 32 on each of its faces at the outer marginal zone of the disc. The impeller has a small clearance 34 between one face and the adjacent inside face of the pump body part 10, a small clearance 36 between the opposite face of the disc and the adjacent face of the second body part 14 and again a small clearance 38 between the rim of the disc and the web portion 19 which separates the two ports.

The impeller is carried on a hub sleeve 40 associated with journal bearing 42 and carries a series of equispaced driven magnet elements 44 in the face adjacent the drive pulley which is described next.

The drive pulley 46 is shown engaged with a pair of V belts 48 for the purpose of driving further engine auxiliaries and has a hub 50 in driving association with the crankshaft and located radially inwardly of the pump body part 10. An oil seal 52 is located therebetween. The pulley carries driving magnets 54 which are suitably located to transmit driving torque to driven magnets 44 for example at the same radial location from the axis 12 as the driven magnets 44.

The pump further comprises containment shell 60 which in the illustrated embodiment has a tubular portion 62 trapped between a journal bearing 42 and a corresponding portion of the pump body at 64. The shell 60 extends generally radially of axis 12 to contain the thrust bearing 72 and thereafter be appropriately positioned between magnets 44 and 54. In this example, the shell 60 essentially extends generally radially of the axis 12 between the opposed magnets 44, 54 and is, in this instance, engaged and retained by the pump body part 14 in the area of the reference numeral 66.

A further bearing, acting as a thrust bearing indicated by the reference numeral 72 is axially trapped between the containment shell 60 and the journal bearing 42. The containment shell 60 may be held in place axially by a thrust washer 74 which may possibly be a Circlip (RTM) or equivalent.

A balance port 70 is provided extending generally radially between the main pump cavity 18 and interior of the pump. The angular location of this in the present embodiment is seen in Figure 1, close to the port 20. In the clockwise direction of rotation of the impeller 30, port 20 is the lower pressure inlet port and higher pressure, near the outlet port 24, causes coolant to leak internally, via clearance 34, through to the bearings 40, 42, and 72, and into a balance chamber 75. Flow of coolant, in this instance acting as lubricant, back through to cavity 18 in the vicinity of lower pressure port 20 is mainly through balance port 70 but also through the clearance 36.

It would be appreciated by those skilled in the art that the described pump differs from the conventional coolant pump in its location, that is at crankshaft level instead of being at the top of the engine. It also differs in its type being a regenerative pump rather than a centrifugal pump. It further differs in being driven by the magnetic coupling action, and again in having a pressurised coolant flow about and through the bearing faces inside the pump. The invention resides in any one of these features, in any combination of them, or in the constructional details which make the feature(s) possible.

In a modification, not shown, the thrust bearing 72 is located between the part 10 and the journal bearing 42. Further, it is possible to locate the port 70 by

way of a channel formed in the part 10 instead of a channel formed in the part 14.

In a modification not shown, the impeller may be a centrifugal type, rather than regenerative or peripheral type, preferably with a hub diameter greater than the largest diameter of the containment shell 66.

Claims

1. A coolant pump for an I.C. engine comprises a pump cavity housing an impeller rotatable about an axis, the impeller axis being located coaxially with the rotational axis of the crankshaft of the engine.
2. A pump according to Claim 1 housing a crankshaft mounted drive pulley for a belt drive system, to drive the coolant pump from that pulley (but preferably not directly that belt).
3. A pump according to Claims 1 or 2 wherein the pump is driven by magnetic coupling using a first set of driving magnets in a face of the pulley and a second set of driven magnets, or torque ring, in the corresponding and adjacent impeller face, with a containment shell located between the two sets.
4. A pump according to any preceding claim wherein the pump cavity is peripherally discontinuous and the impeller is a regenerative type.
5. A coolant pump for an I.C. engine is characterised by a regenerative impeller located in a peripherally discontinuous pump cavity.

6. A pump according to Claim 4 or 5 wherein the impeller comprises a disc formed with radial flutes extending to its periphery and on both faces of the disc, which fluted marginal zone lies in the pump cavity.

7. A pump according to Claims 4, 5 or 6 wherein the cavity formed between two co-operating components of the pump body provides a substantial clearance about the fluted marginal zone only around the major portion of the impeller disc, preferably 330° or thereabouts.

8. A pump according to Claim 7 wherein the cavity provides a suitable running clearance over the face areas of the disc radially inwardly of the fluted marginal zone and preferably over the remaining 30° or thereabouts of the marginal zone.

9. A pump according to any of Claims 4 to 8 wherein the cavity connects to inlet and outlet ports substantially at opposite ends of the substantial clearance portion, that is to say at opposite sides of the minimum clearance portion at the periphery.

10. A pump according to any preceding claim comprising a balance port extending between a generally peripherally extending pumping cavity and the

radially inward zone within the pump to encourage pressurised flow of coolant through the pump as lubricant for bearings journalling the pump impeller.

11. A magnetic coupling driven regenerative impeller coolant pump has a balance port extending between a generally peripherally extending pumping cavity and the radially inward zone within the pump to encourage pressurised flow of coolant through the pump as lubricant for bearings journalling the pump impeller.

12. A pump according to any preceding claim comprising a pump body housing a cavity and an impeller within the cavity, wherein part of the body is formed by the timing case cover adjacent the crankshaft.

13. A coolant pump for an I.C. engine comprising a pump body housing a cavity and an impeller within the cavity, wherein part of the body is formed by the timing case cover adjacent the crankshaft.

14. A pump according to any preceding claim having a magnetically driven impeller, which impeller is rotatable peripherally about the crankshaft of the engine.

15. A pump for an internal combustion engine having a magnetically driven impeller, which impeller is rotatable peripherally about the crankshaft of the engine.

1/3

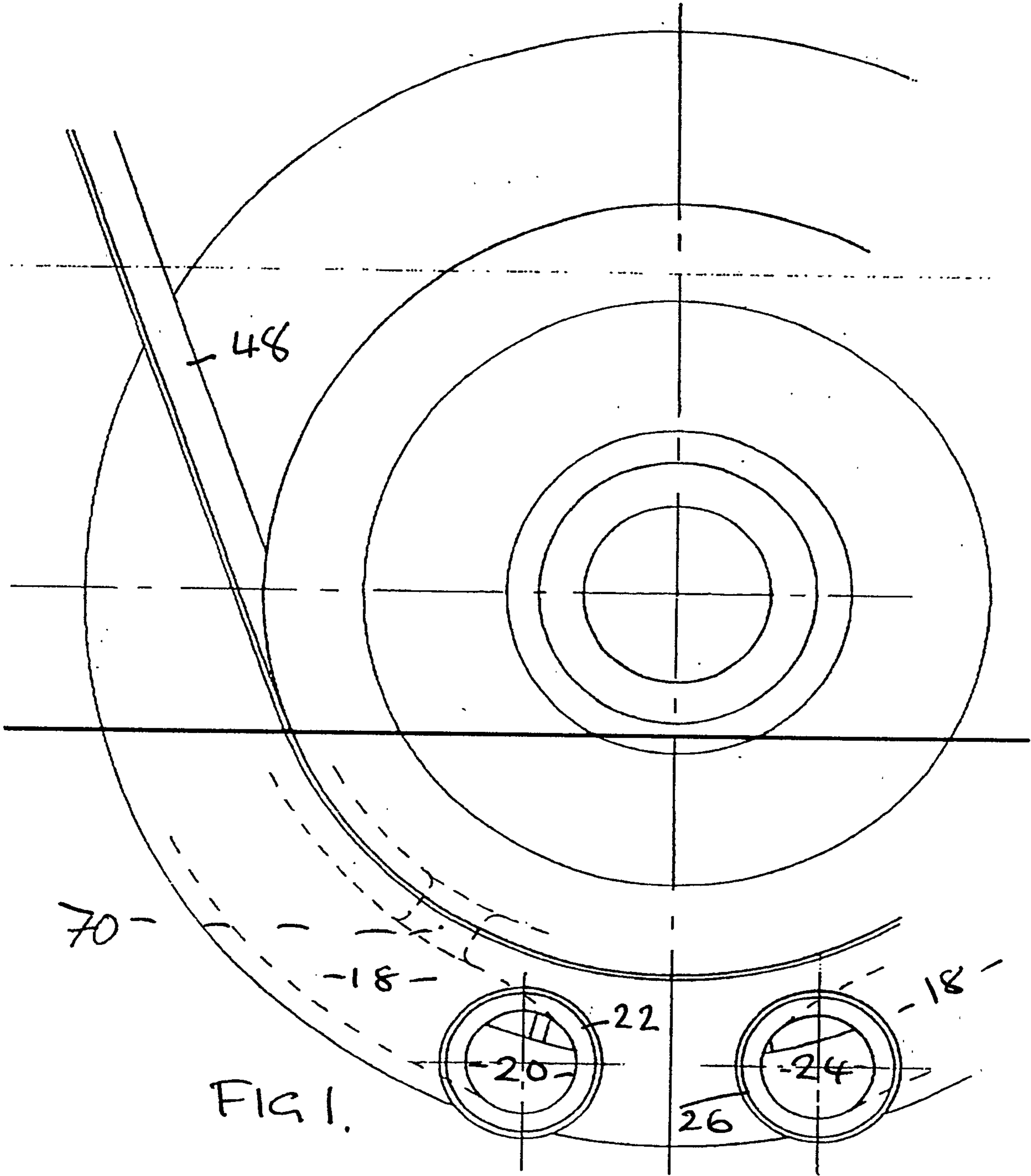

2/3

FIG 2.

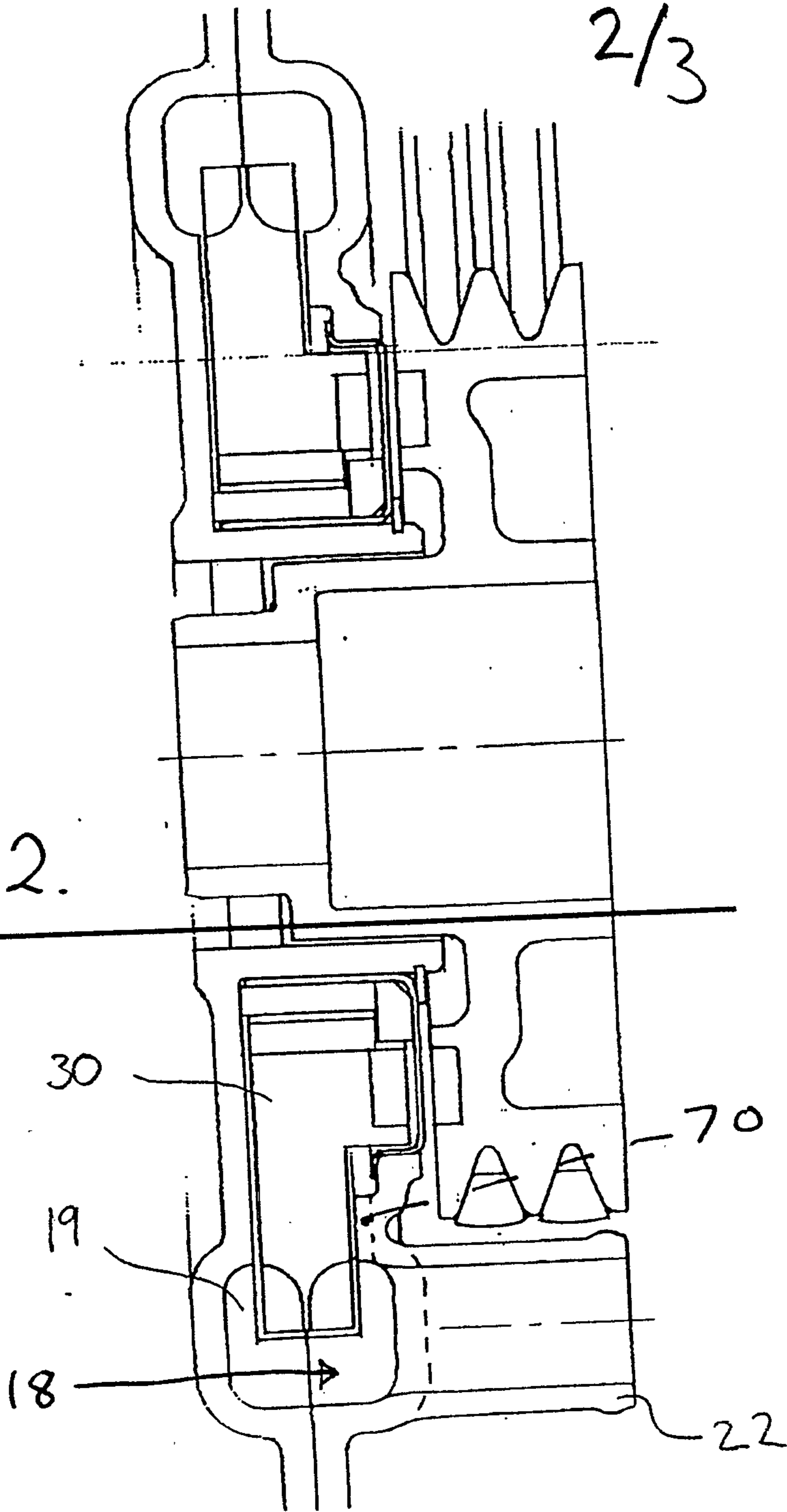
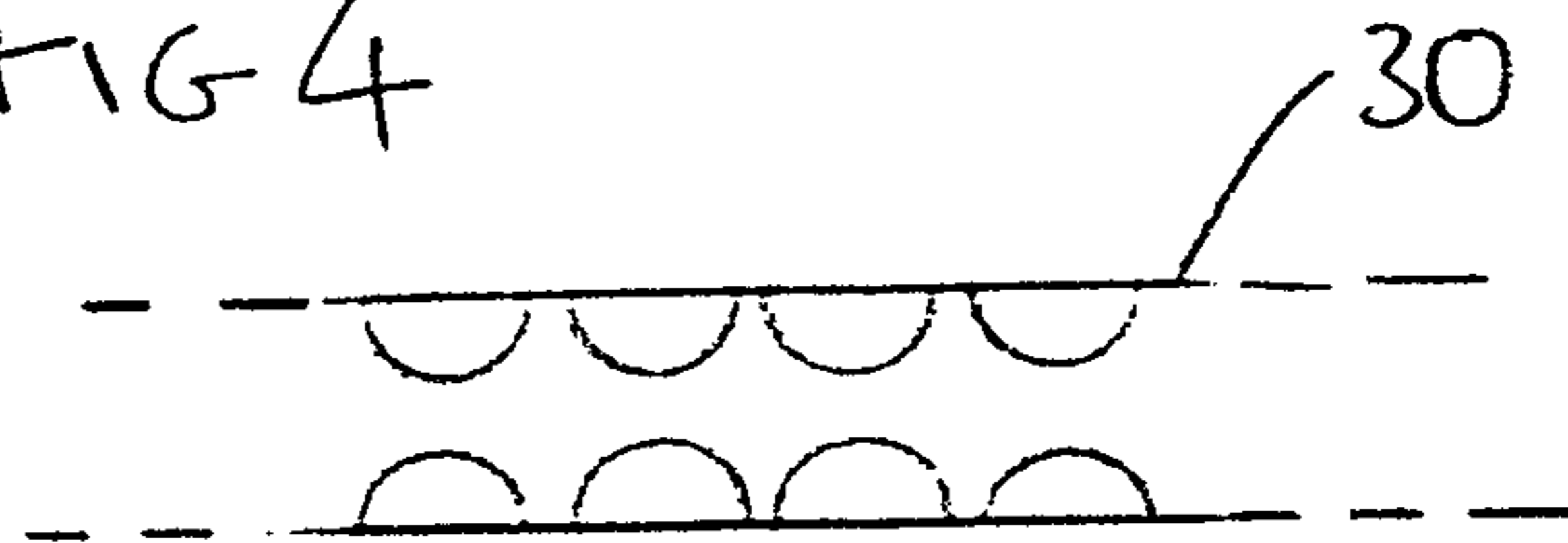

FIG 4



3/3

