



- (51) **International Patent Classification:**
F25C 5/18 (2006.01) F25C 1/22 (2006.01)
- (21) **International Application Number:**
PCT/US2014/013701
- (22) **International Filing Date:**
29 January 2014 (29.01.2014)
- (25) **Filing Language:** English
- (26) **Publication Language:** English
- (30) **Priority Data:**
61/758,072 29 January 2013 (29.01.2013) US
- (71) **Applicant:** TRUE MANUFACTURING CO., INC.
[US/US]; 2001 E. Terra Lane, O'Fallon, Missouri 63366
(US).
- (72) **Inventors:** TRULASKE, SR., Steven L.; 9625 Ladue
Road, St. Louis, Missouri 63124 (US). BROADBENT,
John; 8 Edgewater Is, Lake St. Louis, Missouri 63367
(US).
- (74) **Agent:** NOLTE, Nelson D.; 12412 Powerscourt Drive,
Suite 200, St. Louis, Missouri 63131 (US).

(81) **Designated States** (unless otherwise indicated, for every kind of national protection available): AE, AG, AL, AM, AO, AT, AU, AZ, BA, BB, BG, BH, BN, BR, BW, BY, BZ, CA, CH, CL, CN, CO, CR, CU, CZ, DE, DK, DM, DO, DZ, EC, EE, EG, ES, FI, GB, GD, GE, GH, GM, GT, HN, HR, HU, ID, IL, IN, IR, IS, JP, KE, KG, KN, KP, KR, KZ, LA, LC, LK, LR, LS, LT, LU, LY, MA, MD, ME, MG, MK, MN, MW, MX, MY, MZ, NA, NG, NI, NO, NZ, OM, PA, PE, PG, PH, PL, PT, QA, RO, RS, RU, RW, SA, SC, SD, SE, SG, SK, SL, SM, ST, SV, SY, TH, TJ, TM, TN, TR, TT, TZ, UA, UG, US, UZ, VC, VN, ZA, ZM, ZW.

(84) **Designated States** (unless otherwise indicated, for every kind of regional protection available): ARIPO (BW, GH, GM, KE, LR, LS, MW, MZ, NA, RW, SD, SL, SZ, TZ, UG, ZM, ZW), Eurasian (AM, AZ, BY, KG, KZ, RU, TJ, TM), European (AL, AT, BE, BG, CH, CY, CZ, DE, DK, EE, ES, FI, FR, GB, GR, HR, HU, IE, IS, IT, LT, LU, LV, MC, MK, MT, NL, NO, PL, PT, RO, RS, SE, SI, SK, SM, TR), OAPI (BF, BJ, CF, CG, CI, CM, GA, GN, GQ, GW, KM, ML, MR, NE, SN, TD, TG).

Published:

— with international search report (Art. 21(3))



WO 2014/120846 A1

(54) **Title:** ICE STORAGE BIN WITH IMPROVED DOOR INCORPORATING HOOKS

(57) **Abstract:** An ice maker having an upward and downward swinging door attached to a lower section by at least one hinge. The door is in an upward position when closed and downward position when open. The door has an inner surface that is located adjacent an interior of the ice storage bin when the door is closed and disposed opposite the ice storage bin when the door is open. The interior surface has at least one hook for holding a bucket when the door is in the open position.

ICE STORAGE BIN WITH IMPROVED DOOR INCORPORATING HOOKS

5 This application claims priority to U.S. Provisional Patent Application No. 61/758,072, the contents of which are expressly incorporated herein by reference.

FIELD OF THE INVENTION

 This invention relates to ice makers generally and in particular to a door
10 construction for use on an ice storage bin.

BACKGROUND OF THE INVENTION

 Ice making units in general make relatively large amounts of ice, only a portion of which is used at any one time. The unused portion is kept in an
15 accessible storage bin located below the refrigeration and ice making apparatus. Referring to Figs. 1A-B, a swinging door 10 is typically located above the storage bin 12 that allows access to the stored ice. The swinging door 10 is hinged along a top edge 14 and swings upwardly when opened in order to provide access to the
20 storage bin 12. The door 10 swings past its vertically orientation (Fig. 1B) such that it rests in the open position against a cabinet 16 that contains ice making and refrigeration apparatus. This configuration has long been the standard configuration for providing access through an access door 10 to an ice storage bin
12.

 Alternative configurations have provided for a sliding arrangement of the
25 door 10 within a track 18 (see Fig. 2). This allows the door 10 to slide to a

position parallel and just beneath a top 20 of the ice maker. The configuration of Fig. 2 is used in situations where the refrigeration equipment is located beneath the door and the top of the ice machine. In the configuration of Fig. 1 where the refrigeration equipment is located above the top of ice machine and door, the
5 opened door of Fig. 2 will impede ice falling from the refrigeration equipment.

However, both of these configurations are lacking in that the door can be accidentally set in motion such that it will land on and strike a person who is accessing the opening to retrieve ice from the ice bin. The consequences of being struck with an ice bin door can range from annoying and mildly painful to causing
10 an injury requiring medical attention.

To avoid the situation of falling doors manufacturers have resorted to increased complication. Some manufacturers of ice bins use friction-type hinges to help hold the door open. While this helps, it also introduces several unwanted issues. Friction-type hinges tend to lose friction over time and cease to serve their
15 purpose. Thus, friction hinges lose their ability to hold the door open as the bin ages. Second, friction-type hinges are considerably more expensive than standard hinges. Third, friction-type hinges often use materials that are not designed for use with water, such as iron or steel. Because of this, over time if the hinge gets wet, it may rust. The rust will inevitably fall from the hinge and contaminate the
20 ice.

Obviously, there exists a need in the art for an effective solution to reduce or eliminate situations where individuals retrieving ice from ice bins are struck by ice bin doors.

SUMMARY OF THE INVENTION

The present invention comprises an ice maker comprising a lower section comprising an ice storage bin for storing ice and an upper section containing at least a portion of a refrigeration circuit. The upper section also has a cooling plate on which ice is formed, the ice falling from the cooling plate of the upper section to lower section upon completion of a cooling cycle of the ice maker. The lower section comprises an upward and downward swinging door attached to the lower section by at least one hinge. The door is in the upward position when closed and downward position when open. Also, the door having an inner surface that is located adjacent an interior of the ice storage bin when the door is closed and disposed opposite the ice storage bin when the door is open. That interior surface comprises at least one hook for holding a bucket when the door is in the open position.

15

DESCRIPTION OF THE DRAWINGS

FIG. 1A is a perspective view of an ice maker and bin with its door in the closed position according to the prior art;

FIG. 1B is a perspective view of an ice maker and bin with its door in the open position according to the prior art;

FIG. 2 is a perspective view of an ice maker/bin with an upwardly lifting sliding door according to the prior art;

FIG. 3 is a perspective view of an ice storage bin according to the present invention with its door in the open position;

FIG. 4 is a perspective view of an ice storage bin according to the present invention with its door in the closed position;

FIG. 5 is a perspective view of an outer surface of an ice storage bin door according to the present invention;

5 FIG. 6 is a perspective view of an inner surface of an ice storage bin door according to the present invention; and

FIG. 7 is an enlarged view of a hook of an ice bin storage bin door according to the present invention.

10 DESCRIPTION OF THE PREFERRED EMBODIMENT

While this invention is susceptible of embodiment in many different forms, there is shown in the drawings and will herein be described in detail a preferred embodiment of the invention with the understanding that the present disclosure is to be considered as an exemplification of the principles of the invention and is not intended to limit the broad aspect of the invention to the
15 embodiment illustrated.

Referring to Figs. 3-4, the ice storage bin 32 comprises right, left and rear sides, 34 as well as a front side 36 that defines an opening 38. A door 40 is attached to the front side 36 along a top edge 42 thereof. The door swings from
20 an open position (Fig. 3) to a closed position (Fig. 4). In the open position (Fig. 3), gravity holds the door 40 in place such that it cannot fall and strike a person accessing ice from the ice storage bin 32.

A hinge 44 attaches the door to the ice storage bin 32 along a bottom edge 42. The hinge mechanism may consist of hinges on the outer edges of the door or may comprise a plurality of discrete hinges along edge 42.

Referring to Fig. 5-7, in another aspect of the present invention, the door 5 40 has an outer surface 46 which faces outwardly when the door 46 closed and an inner surface 48 which faces outwardly when the door 40 is open (Fig. 5). The inner surface 48 comprises one or more hooks 42 that are preferably integrally molded as part of the door 40 (Fig. 6).

The hook 42 is dimensioned so that bucket to be filled with ice by a user 10 can easily be placed within a hook and held in position near the ice storage bin 32. Referring to Fig. 7, the hook 42 preferably forms an arcuate section 50 for holding an ice bucket handle. The arcuate section 50 terminates in a point 52 whereby the hook comprises a downwardly sweeping support section 54 which provides structural support for the hook and prevents the weight of a filled ice bucket from 15 breaking or bending the hook section. The door is preferably molded as a single piece in a blow-molding process using a suitable resin such as high impact polystyrene (HIPS), ABS or PVC.

The above example shows that the invention, as will be defined by the claims, has far ranging application and should not be limited merely to the 20 embodiment shown and described in detail. Instead the invention should be limited only to the explicit words of the claims, and the claims should not be arbitrarily limited to the embodiment shown in the specification. The scope of

protection is only limited by the scope of the accompanying claims, and the Examiner should examine the application only on that basis.

We claim:

1. An ice maker comprising:
a lower section comprising an ice storage bin for storing ice;
an upper section containing at least a portion of a refrigeration circuit and
5 a cooling plate on which ice is formed, the ice falling from the cooling plate of the
upper section to lower section upon completion of a cooling cycle of the ice
maker; and
the lower section comprising an upward and downward swinging door
attached to the lower section by at least one hinge, the door being in the upward
10 position when close and downward position when open, the door having an inner
surface that is located adjacent an interior of the ice storage bin when the door is
closed and disposed opposite the ice storage bin when the door is open.
2. The ice marker of claim 1 wherein the interior surface of the door
15 comprises at least one hook for holding a bucket when the door is in the open
position.
3. The ice maker of claim 2 wherein the hook is integrally formed
with the door.
20
4. The ice maker of claim 2 wherein the door is formed from a
polymeric material and the hook is integrally formed from the polymeric material.

5. The ice maker of claim 4 wherein the hook comprises an arcuate section that forms an arcuate section that terminates in a point and then comprises a downwardly sweeping support section.

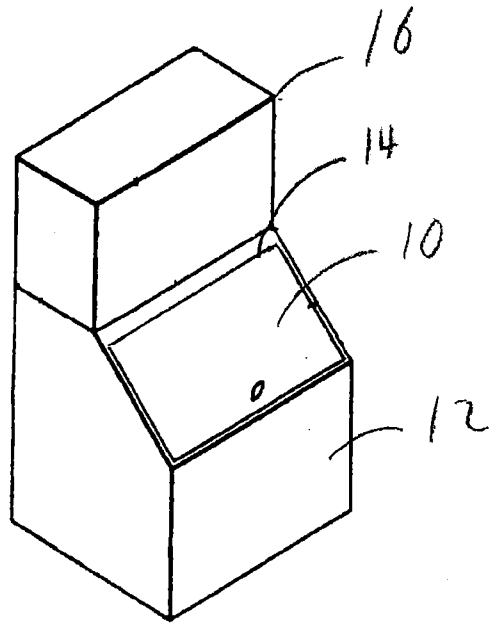

Fig. 1A

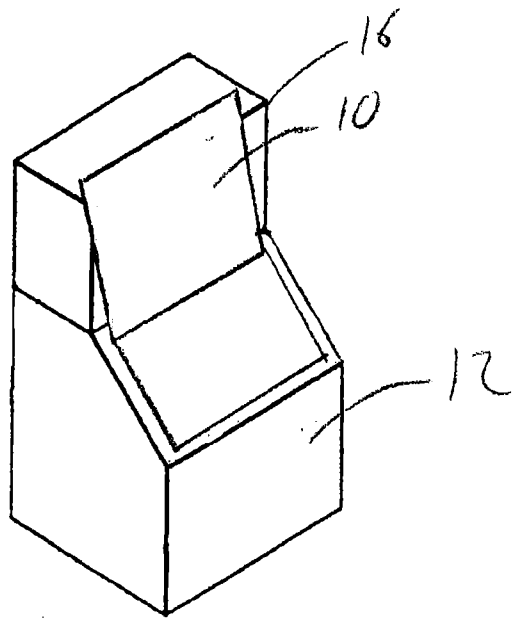

Fig. 1B

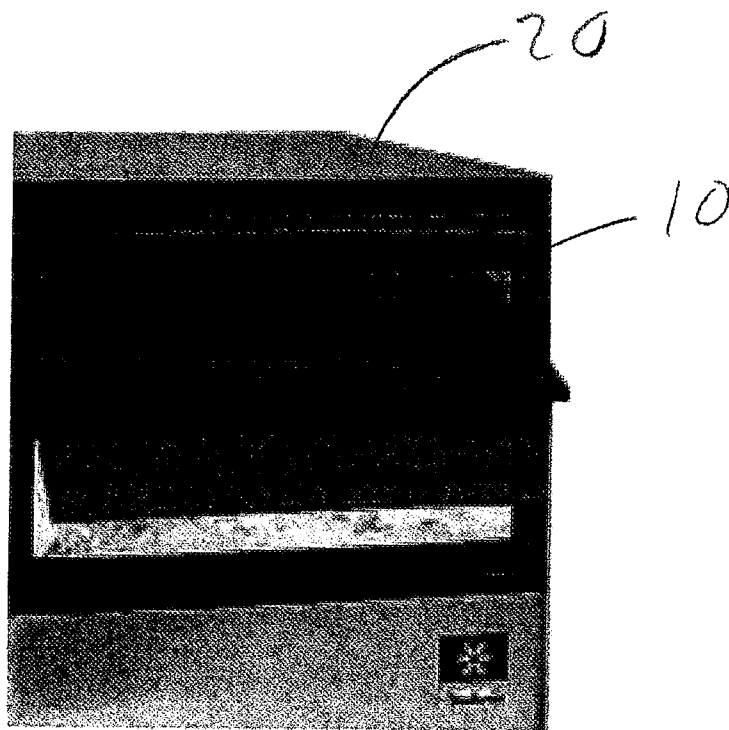
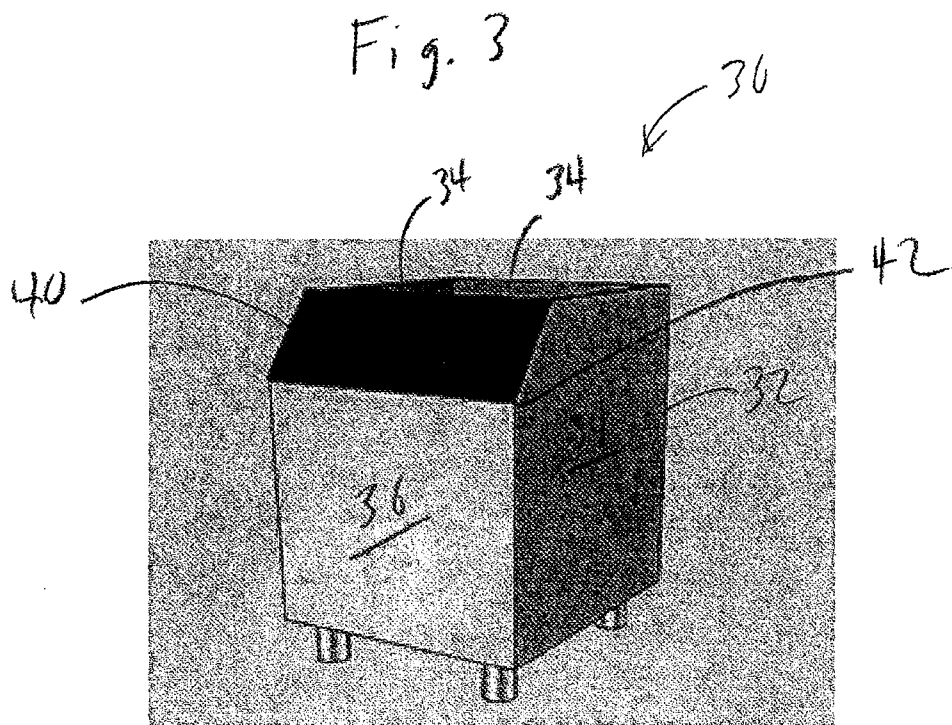
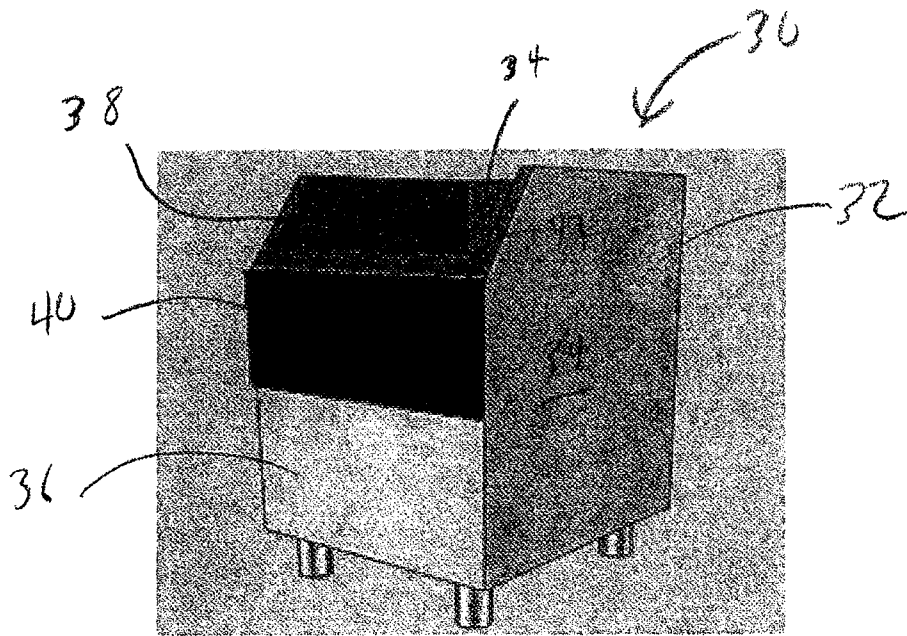
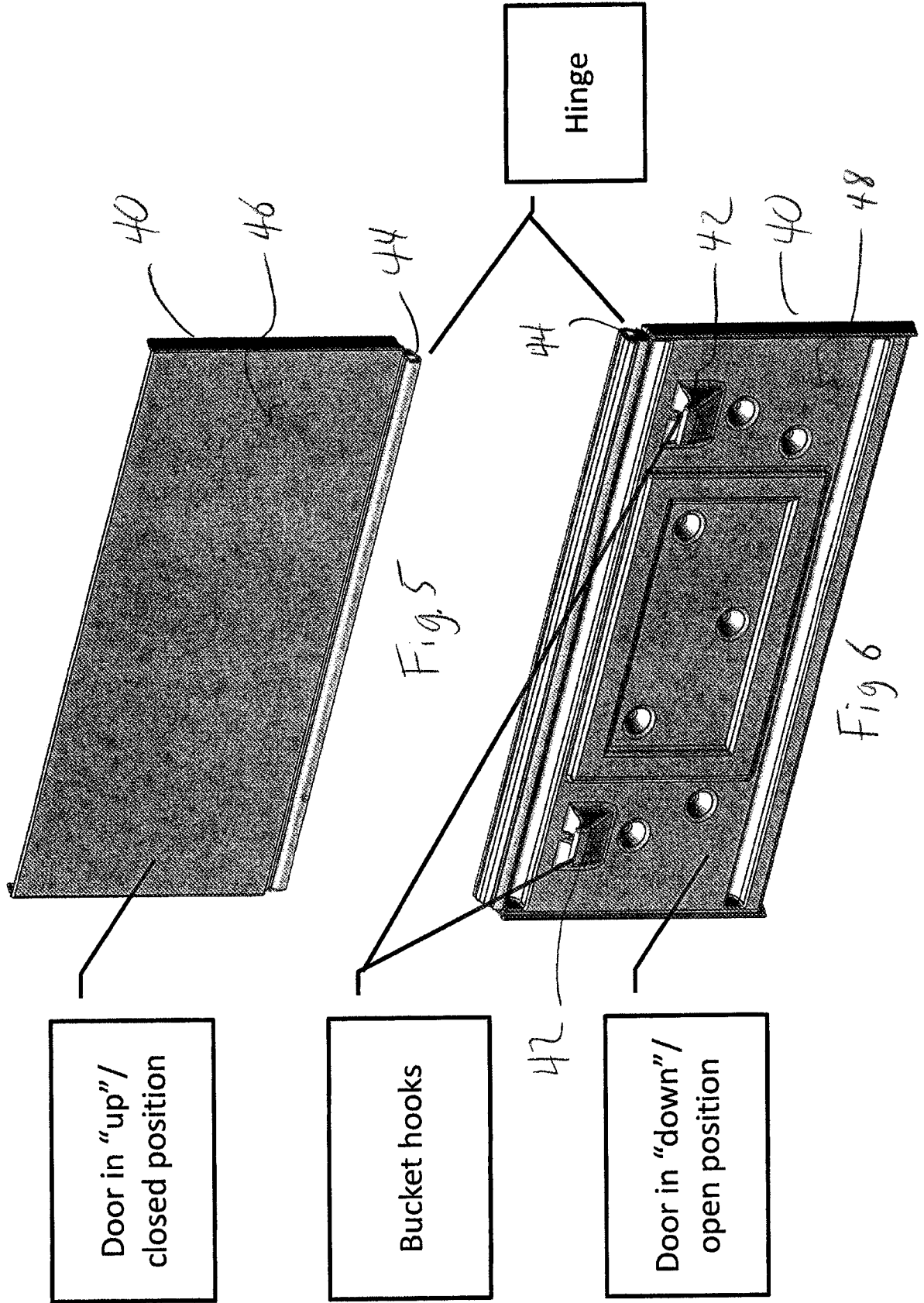
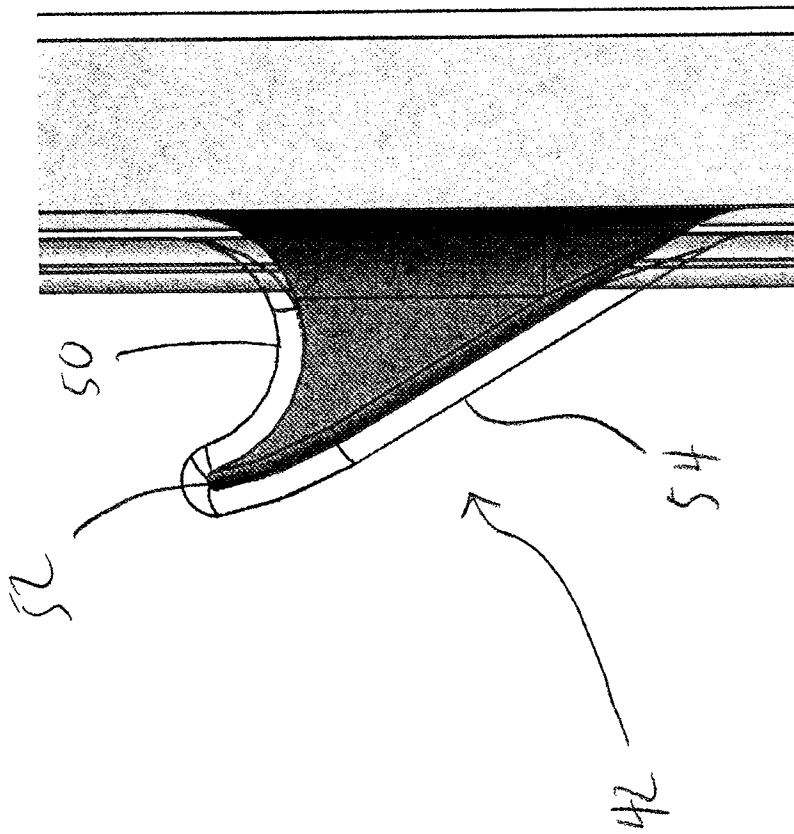

Fig. 2







Hook cross-section

Fig. 7

INTERNATIONAL SEARCH REPORT

International application No.

PCT/US 2014/013701

A. CLASSIFICATION OF SUBJECT MATTER		
<i>F25C 5/18 (2006.01)</i> <i>F25C 1/22 (2006.01)</i>		
According to International Patent Classification (IPC) or to both national classification and IPC		
B. FIELDS SEARCHED		
Minimum documentation searched (classification system followed by classification symbols)		
F25C 1/00-1/24, 5/00-5/18, F25D 23/02-23/06, 25/00-25/02, 11/00-11/02		
Documentation searched other than minimum documentation to the extent that such documents are included in the fields searched		
Electronic data base consulted during the international search (name of data base and, where practicable, search terms used)		
Espacenet, USPTO DB, RUPAT OLD, RUPAT, RUABU1, PAJ, PatSearch (RUPTO internal)		
C. DOCUMENTS CONSIDERED TO BE RELEVANT		
Category*	Citation of document, with indication, where appropriate, of the relevant passages	Relevant to claim No.
Y	JP H10300299 A (MANITOWOC FOODSERVICE GROUP IN) 13.11.1998, fig. 1-11	1-5
Y	WO 2007/090695 A2 (BSKH BOSH UND SIMENS KHAUSGERETE GMBKH) 20.03.2010, fig.1, 2	1-5
Y	KR 20030040791 A (LG ELECTRONICS INC) 23.05.2003, fig. 2, 3	2-5
Y	SU 638248 A (INOSTRANNAYA FIRMA "SOSIETE PUR LA RESHERSH E LE DEVELOPMENT TEKHOLODZHNIK S.A.) 09.02.1979, col. 1, fig. 13	3-5
Y	CN 202126136 U (HAIER GROUP CO LTD et al.) 25.01.2012, fig. 3	5
<input type="checkbox"/> Further documents are listed in the continuation of Box C. <input type="checkbox"/> See patent family annex.		
*	Special categories of cited documents:	"T" later document published after the international filing date or priority date and not in conflict with the application but cited to understand the principle or theory underlying the invention "X" document of particular relevance; the claimed invention cannot be considered novel or cannot be considered to involve an inventive step when the document is taken alone "Y" document of particular relevance; the claimed invention cannot be considered to involve an inventive step when the document is combined with one or more other such documents, such combination being obvious to a person skilled in the art "&" document member of the same patent family
"A"	document defining the general state of the art which is not considered to be of particular relevance	
"E"	earlier document but published on or after the international filing date	
"L"	document which may throw doubts on priority claim(s) or which is cited to establish the publication date of another citation or other special reason (as specified)	
"O"	document referring to an oral disclosure, use, exhibition or other means	
"P"	document published prior to the international filing date but later than the priority date claimed	
Date of the actual completion of the international search		Date of mailing of the international search report
27 March 2014 (27.03.2014)		17 April 2014 (17.04.2014)
Name and mailing address of the ISA/ FIPS Russia, 123995, Moscow, G-59, GSP-5, Berezhkovskaya nab., 30-1		Authorized officer T. Darina
Facsimile No. +7 (499) 243-33-37		Telephone No. 8(495)531-65-15