



(22) Date de dépôt/Filing Date: 2000/03/30

(41) Mise à la disp. pub./Open to Public Insp.: 2001/09/30

(51) Cl.Int.⁷/Int.Cl.⁷ B25H 3/02, A45C 11/00, B65D 85/20

(71) Demandeur/Applicant:
MAXTECH MANUFACTURING LTD., CA

(72) Inventeur/Inventor:
VASUDEVA, KAILASH C., CA

(74) Agent: BORDEN LADNER GERVAIS LLP

(54) Titre : TROUSSE A OUTILS A MODULES INTEGRABLES

(54) Title: TOOL CASE WITH SNAP-IN MODULES

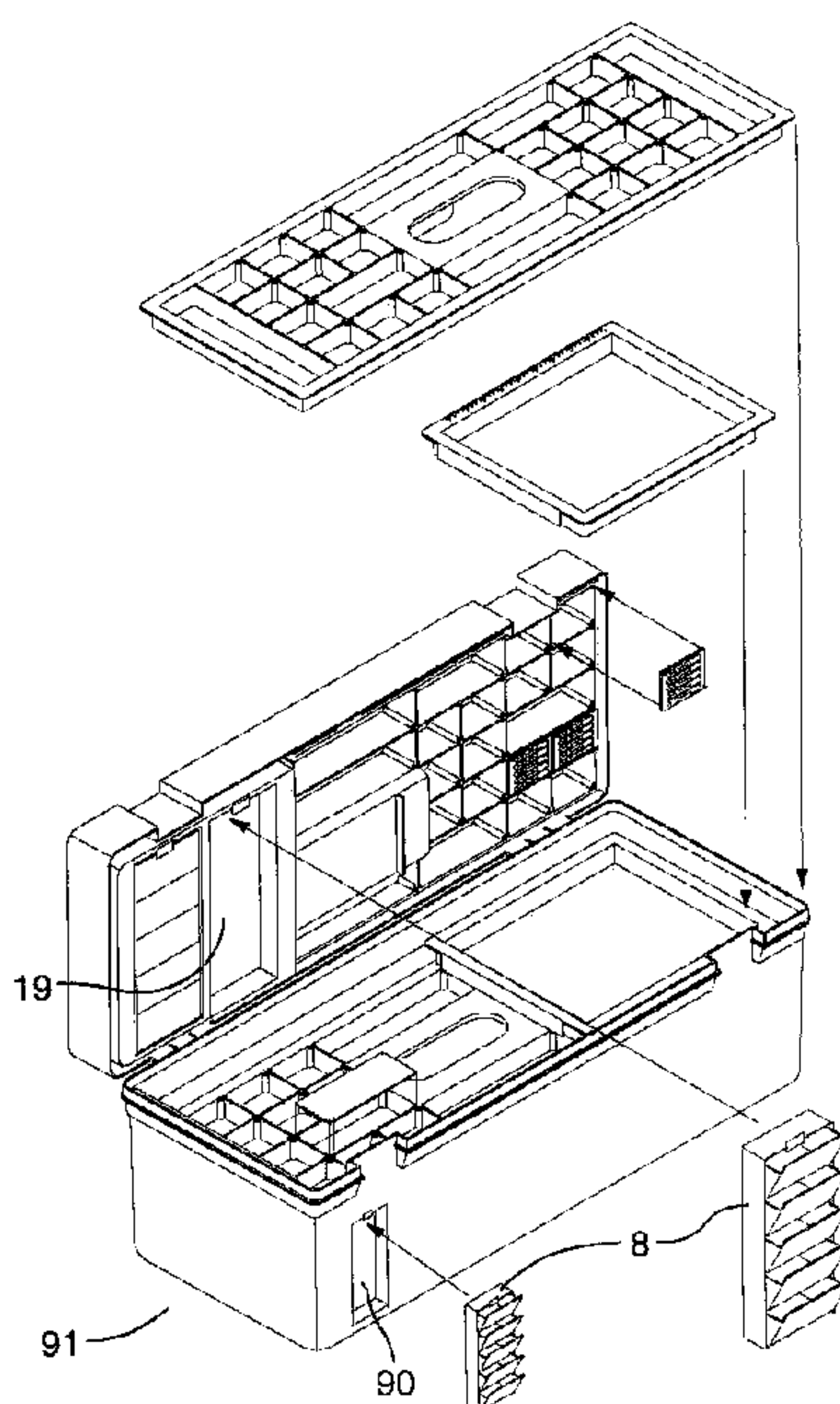

(57) Abrégé/Abstract:

A tool case with an additional storage space, which is accessed from the inside of the tool case. The storage space may be fitted with various pre-assembled snap-in storage modules to provide the user with the flexibility of storing a wide variety of items in a wide variety of ways, depending on the user's needs. For example, the compartment may be fitted with a snap-in module comprising a series of rotating storage containers according to the preferred embodiment of the invention. Alternatively, the snap-in modules can comprise a series of sliding drawers, or a single rotating storage container, or any other tool or component holder. In the invention, a rectangular opening is defined within the inner surface of the box portion of the tool case. Interior walls project upwardly from the edge of the opening to preferably define a storage space which accommodates a snap-in module. The module is secured within the storage space by inserting two tabs projecting outwardly from the first side of the module into corresponding slits located within the adjacent interior wall. The module is then rotated into the recess so that a plastic arm projecting away from the second side of the module engages a lip protruding from the adjacent interior wall. The lip is engaged by a jaw molded to the distal end of the arm.

ABSTRACT

A tool case with an additional storage space, which is accessed from the inside of the tool case. The storage space may be fitted with various pre-assembled snap-in storage modules to provide the user with the flexibility of storing a wide variety of items in a wide variety of ways, depending on the user's needs. For example, the compartment may be fitted with a snap-in module comprising a series of rotating storage containers according to the preferred embodiment of the invention. Alternatively, the snap-in modules can comprise a series of sliding drawers, or a single rotating storage container, or any other tool or component holder. In the invention, a rectangular opening is defined within the inner surface of the box portion of the tool case. Interior walls project upwardly from the edge of the opening to preferably define a storage space which accommodates a snap-in module. The module is secured within the storage space by inserting two tabs projecting outwardly from the first side of the module into corresponding slits located within the adjacent interior wall. The module is then rotated into the recess so that a plastic arm projecting away from the second side of the module engages a lip protruding from the adjacent interior wall. The lip is engaged by a jaw molded to the distal end of the arm.

TOOL CASE WITH SNAP-IN MODULES

This invention relates to a tool case, particularly of the type used to display a tool set at the point of sale, and to subsequently store the tool set. Such tool cases are commonly referred to as "gift cases".

5 Cases of the general type are well known, and typically include a base in the form of an open-topped box, and a lid hinged or otherwise mated with the box portion, with a clip or other means to secure the lid in the closed position. The case typically also contains a panel with a number of recesses to accommodate various tools and components, such as a screwdriver and various bits therefor, for example.

10 However, this conventional configuration does not efficiently use the available space in the case because a large volume of unused space is left between the panel and the bottom of the box portion of the case.

In view of the above, it is an object of the invention to provide an improved tool case with one or more additional storage space areas which is/are accessed from the inside of the tool case. For greater flexibility, the storage space may be fitted with various pre-assembled snap-in storage modules to provide the user with the flexibility of storing a wide variety of items in a wide variety of ways, depending on the user's needs. For example, the compartment may be fitted with a snap-in module comprising a series of rotating storage containers according to the preferred embodiment of the invention. Alternatively, the snap-in modules can comprise a series of sliding drawers, or a single rotating storage container, or any other tool or component holder.

20 In the invention, a preferably rectangular opening is defined within the inside surface of the box portion of the tool case. Alternatively, the opening is defined in the inside surface of the lid portion of the tool case. Interior walls project upwardly from the edge of the opening to preferably define a storage space which accommodates a snap-in module. The module is secured within the storage space by any suitable means, such as by inserting two tabs projecting outwardly from the first side of the module into corresponding slits located within the adjacent interior wall. The module is then rotated into the recess so that a plastic arm projecting away from the second side of the module engages a lip protruding from the adjacent interior wall. The lip is engaged by a jaw molded to the distal end of the arm.

A preferred tool case according to the invention comprises a box portion, a lid pivotably connected to the box portion, a storage space defined within the inside surface of the box portion, and at least one storage module securable within the storage space.

5 The storage module is either removably securable within the storage space or non-removably securable within the storage space.

The storage space further advantageously comprises an opening defined within the inside surface of the box portion and a plurality of integrally molded interior walls projecting upwardly from the opening.

10 The at least one module further preferably comprises at least one tab projecting outwardly from a first side of the module, an arm flexibly connected to a second side of the module, a jaw defined within the distal end of the arm. The tool case further comprises at least one slit defined within one of the interior walls adjacent to the first side of the module, a lip protruding from one of the interior walls adjacent to the
15 second side of the module, whereby the module may be secured within the storage space by inserting the at least one tab projecting from the module into the slit defined within the interior wall, and the jaw defined within the distal end of the arm engages the lip.

In a further embodiment, the at least one module further comprises a
20 module body, a recess defined within the module body, a plurality of containers pivotably mounted inside the recess connected along at least one side by a gang bar, the containers configured to pivot in unison between open and closed positions, such that in the closed position, an outer face of each container is coplanar and flush with the inner surface of the box portion, and in the open position, the outer face projects
25 outwardly, exposing openings into the containers.

In yet a further embodiment, the at least one module further comprises a module body, a recess defined within the module body to form a storage container, and a door pivotably connected to the body.

In another embodiment of the invention, the at least one module further
30 comprises a module body, a recess defined within the module body and a plurality of drawers slidably mounted within the recess.

Still a further embodiment has a module further comprising a module

body, a recess defined within the module body, a plurality of wedge-shaped storage containers pivotably mounted within the recess, the containers configured to pivot individually between open and closed positions, such that in the closed position, an outer face of each container is coplanar and flush with the inner surface of the box portion, and in the open position, the outer face projects outwardly, exposing openings into the containers.

In still a further embodiment, the at least one module further comprises a module body, a recess defined within the module body, a multi-compartment storage container comprising: three integral rectangular faces, two integral identical parallel four-sided outer walls joining the three rectangular faces, an open fourth face to provide access to the container, and two integral dividing walls defining three storage compartments. The container is pivotably mounted within the recess, the container configured to pivot between open and closed positions, such that in the closed position, an outer face of the container is coplanar and flush with the inner surface of the box portion, and in the open position, the outer face projects outwardly, exposing opening into the compartments.

Further, the at least one module advantageously comprises a module body, a recess defined within the module body, a door pivotably connected to the body, and a plurality of integrally molded shelves projecting outwardly from the inner face of the door. The door is configured to pivot between open and closed positions, such that in the closed position, an outer face of the door is coplanar and flush with the inner surface of the box portion, and in the open position, the outer face projects outwardly, exposing the shelves.

A further embodiment of a tool case advantageously comprises a large box portion, a lid pivotably connected to the box portion, multiple tool and component storage spaces defined within interior or exterior surfaces of the box portion and the lid, and at least one storage module securable within at least one of the storage spaces.

Yet a further embodiment of a tool case according to the invention comprises a box portion defining a main storage area, a lid pivotally connected to the box portion, a recess defined in at least one interior surface of the tool case, and at least one removable module, each removable module being removably securable in the recess and configured to provide a secondary storage area, the at least one removable

module having a plurality of separate storage compartments accessible when the at least one removable module is secured in the recess. One of the compartments is preferably pivotable relative to the module, between open and closed positions. Preferably, the tool case is arranged such that in the closed position, an outer face of each of the compartments is coplanar and flush with one the interior surface in which the recess is defined. Advantageously, there are plural compartments pivotable relative to their module, between open and closed positions. The compartments are preferably ganged together for ganged movement between the open and closed positions, for instance by virtue of a gang bar connecting each of the compartments.

A further embodiment of the invention has a tool case comprising a box portion defining a main storage area, a lid pivotally connected to the box portion, a recess defined in at least one exterior surface of the tool case, and at least one non-removable module, each removable module being securable in the recess and configured to provide a secondary storage area, the at least one non-removable module having a plurality of separate storage compartments accessible when the at least one non-removable module is secured in the recess.

In order that the invention may be more clearly understood, the preferred embodiment thereof will now be described in detail by way of example, with reference to the accompanying drawings, in which:

Fig. 1 is an exploded perspective view of the tool case showing the storage space and the snap-in module according to one embodiment of the invention;

Fig. 2 is an exploded perspective view from the top of the tool case showing a tool and component holding panel;

Fig. 3 is a perspective view from the underside of the tool case;

Fig. 4 is an exploded perspective view showing a "drop-bin module" installable in the storage space;

- Fig. 5 is a cross-sectional view showing the removal of the drop-bin module;
- Fig. 5A is a cross-sectional view of the securing mechanism for the module;
- Fig. 6 is an exploded perspective view of the drop-bin module and case;
- 5 Fig. 7 is a perspective view of an alternative storage container module in the case;
- Fig. 8 is an exploded perspective view of the alternative storage container module and case;
- 10 Fig. 9 is a perspective view of a sliding drawer module in the case;
- Fig. 10 is an exploded perspective view of the sliding drawer module in the case;
- 15 Fig. 11 is a perspective view of a wedge-shaped container module in the case;
- Fig. 12 is an exploded perspective view of the wedge-shaped container module and the case;
- 20 Fig. 13 is a cross-sectional view of the wedge-shaped container module;
- Fig. 13A is cross-sectional view of the securing mechanism for the wedge-shaped containers;
- 25 Fig. 14 is a perspective view of a multi-compartment container module in the case in the closed position;
- Fig. 15 is a perspective view of the multi-compartment container module in the case in the open position;
- 30

- Fig. 16 is an exploded perspective view of the multi-compartment container module;
- Fig. 17 is a perspective view of a multiple shelf module in the case;
- 5 Fig. 18 is an exploded perspective view of the multiple shelf module and the case;
- Fig. 19 is an exploded perspective view of a preferred embodiment of the invention, showing the snap-in modules connected to a tool box;
- Fig. 20 is a schematic top view of a tool case according to a further embodiment of the invention, showing a snap-in module inside a tool box;
- 10 Fig. 21 is a schematic top view of a tool case according to still a further embodiment of the invention, showing a snap-in module inside a tool box;
- Fig. 22 is a schematic sectional side view along line A-A of Fig. 21, showing the tool box with its lid closed;
- 15 Fig. 23 is a schematic sectional side view along line A-A of Fig. 21, showing the tool box with its lid opened and removed and the storage containers in their outwards pivoted position;
- Fig. 24 is a schematic top view of a tool case according to yet a further embodiment of the invention, showing a snap-in module inside a tool box;
- 20 Fig. 25 is a schematic sectional side view along line B-B of Fig. 24, showing the tool box with its lid closed;
- Fig. 26 is a schematic sectional side view along line B-B of Fig. 24, showing the tool box with its lid opened and removed and the storage containers in their outwards pivoted position;

Fig. 27 is a top view of even still a further embodiment of the invention, showing a tool box with a slide-in module fully slid inside the tool box;

Fig. 28 is a schematic sectional side view along line C-C of Fig. 27, showing the tool box with its lid opened and removed and the slide-in storage container in position to be slid inside the tool box; and

Fig. 29 is a schematic sectional side view along line D-D of Fig. 27, showing the tool box with its lid opened and removed and the slide-in storage container fully inserted into the tool box.

Referring to the drawings, Fig. 1 shows the tool case which includes a main box portion **1** with a handle **2** molded to the front edge thereof, as well as a preferably transparent lid **3** hinged to the box portion, for example, by two hinges **4**, and secured to the box portion by a clip **5**. Preferably, the tool case is made entirely from plastic.

A generally rectangular opening **6** defined within the bottom surface of the box portion. Molded interior walls **7** project upwardly from the edges of the rectangular opening into the box portion to define a storage space **15** which accommodates a snap-in module **8**, such as the "drop bin assembly" shown in Figs. 1-6.

Fig. 2 shows a plastic panel **9**, preferably molded with a raised portion **10** located over the rectangular opening to provide extra space for the snap-in module. However, a flat panel could be used in the tool case, although the space available for a snap-in module would, of course, be smaller. The panel is secured to the box portion by any suitable means, such as, for example, by inserting posts **11** protruding from the panel into corresponding sleeves **12** molded onto the box portion. For additional support, the panel rests on preferably three support members **13** along the side of the box portion adjacent to the hinges. Various shapes **14** are molded within the panel to accommodate corresponding tools with substantial depth, as well as components such as screwdriver bits and sockets. The shapes defined within the raised portion of the panel and components retained therein have little depth, and are, therefore, only adapted to retain components such as screwdriver bits and sockets. The shapes are

molded in such a way that the corresponding tools and components can be secured by snapping same into the corresponding shapes **14** in a conventional manner, so that if the tool case is oriented with the lid facing downward, the tools stored in the first panel do not fall out of their designated shapes .

5 Figs. 1-5 show an embodiment of the invention where a "drop-bin" module **8** is secured within the storage space **15** by snapping the module into the interior walls **7** by any suitable means. For example, two tabs **16** extending outwardly from a first side **19** of the of the module are inserted into corresponding slits **20** located within an adjacent interior wall. The module is then rotated into the storage space so that a flexible molded plastic arm **21** projecting upwardly and away from the second side **22** 10 of the module engages a lip **23** protruding from the adjacent interior wall. The lip is engaged by a jaw **24** located at the distal end of the arm which snaps onto said lip to secure the module to the box portion. A semi-circular depression **27** is defined within the box portion surrounding the lip.

15 As best shown in Fig. 5, the module is removed by the user sliding his/her finger into the semi-circular depression **27** which allows the finger to engage the arm **21** and pull it away from the box portion, freeing the module to be rotated out of the storage space **15**.

20 Fig. 6 shows the preferably five identical drop-bin storage containers **28**, each having two identical parallel five-sided walls **17** which are joined by three generally rectangular faces **18** to form the container. The two remaining faces are open to provide access to the storage container. The storage containers are preferably molded from clear plastic to permit the user to examine the contents without opening the containers.

25 In the closed position, the faces of the storage containers preferably form a single plane flush with the bottom surface of the box portion so that the bottom of the tool case can rest flat on a work surface when the user has opened the lid **3** to access the tools in the panel **9**.

30 The storage containers locate within a recess **90** defined within the body **91** of the module, and each container is joined to the sides of the recess by a male connection pin **25** which extends outwardly at a right angle from the two walls of each storage container. A corresponding recessed female connection means **26** adapted to receive the pins of each storage container is molded into both sides of the recess

adjacent to the walls of the containers. The pin of each storage container is inserted into the corresponding female connection means, such that the containers are prevented from falling out of the recess, but are permitted to freely rotate. Alternative methods of pivotally connecting the storage containers to the box portion will be apparent to those skilled in the art and are within the scope of the invention.

The storage containers are joined, preferably, by two gang bars **30** to allow the containers to only move in unison. The two gang bars are located in two corresponding grooves **93** defined within the sides of the recess. The gang bars are connected to the storage containers by protruding cylindrical male connections **31** located along their length which fit snugly into female openings **32** in the side walls of each storage container. It should be clear to those skilled in the art that only one gang bar could be employed.

The storage containers are prevented from freely rotating by a plastic clasp configuration **35** molded from one piece of plastic, secured to the body **91** of the module, and preferably located adjacent to the storage container closest to the handle. A section of the clasp **38** molded into aperture is snapped by conventional means onto a co-operating plastic member **39** extending outwardly from the body. The clasp configuration also includes a ridge **36** extending over the face of the storage container which is flush with the bottom of the tool case to secure the container in the closed position, as well as a catch **37** to permit the user to easily grasp the clasp configuration. To pivot the containers to the open position, the user grasps the catch and pulls it away from the storage containers lifting the ridge which extends over the adjacent storage container and restricts its rotation. The user can freely pivot the storage container adjacent to the clasp into an open position, and when he/she does so, he/she also moves the gang bar connected thereto, which gang bar then imparts the motion to all the other containers causing them to move in unison. It should be noted, however, that other suitable means of securing the storage containers to the box portion may be used and such means would be within the scope of the invention.

It should be understood that the above description relates to the preferred embodiment by way of example only. Many variations on the invention will be obvious to those knowledgeable in the field, and such obvious variations are within the scope of the invention as described and claimed, whether or not expressly described.

For example, Figs. 7 and 8 show an alternative embodiment of the invention where a recess **90** is defined within the body **46** of the snap-in module **8** to define a generally box-shaped storage container **41**. A door **42** is rotatably connected to the body by any suitable means, such as, for example, a living hinge **45**. The door is secured to the storage container by a plastic clasp configuration **35** snapped onto a plastic member **39**, as described in the preferred embodiment, such that when the door is in the closed position it is flush with the bottom surface of the box portion. The module is snapped into the storage space **15** in the same manner as the preferred embodiment described above.

Figs. 9 and 10 show an alternative embodiment of the invention where the snap-in module **8** comprises four box-shaped drawers **50** secured within a recess **90** defined within the body **53** of the module. A molded handle **51** defined within the outer face **52** of each drawer. It should be clear to those skilled in the art that the module can be configured with any number of drawers, and such variations are clearly within the scope of this invention. The drawers are slidably connected to the body by any suitable means. For example, molded rails **54** projecting outwardly from the bottom face of each drawer slide within corresponding channels **55** defined within the inner surface of the walls of the body. The drawers are prevented from falling out of the body of the module by drawer tabs **56** molded to the top of the inner face of each drawer. In the closed position, the outer face of each drawer is flush with the bottom surface of the box portion **1**. Again, this module is secured within the storage space in the same manner as the preferred embodiment described above.

Figs. 11 to 13 show an alternative embodiment of the invention four wedge-shaped storage containers **60** are secured within a recess **90** defined within the body **64** of the snap-in module **8**, although any number of storage containers may be fitted within the module and such variations are within the scope of this invention. Each storage container is defined by a converging outer face **61** and inner face **62** joined by a rounded container wall **63**. A handle **51** is defined within the outer face of each container. Each container is rotatably connected to the body by any suitable means. For example, a C-shaped channel **65** molded to the edge of the container where the outer and inner faces converge, is snapped onto to a molded cylindrical rail **66** running along the top of the inner face of the body. In the closed position, the outer face of each

container is flush with the bottom surface of the box portion and is secured in place by a flexible molded button **67** protruding outwardly from the outer face of each container, and from an identical button **69** protruding from the side of the body adjacent to the rearmost container. The button snaps into a corresponding pocket **68** defined within the
5 outer face of an adjacent container, and the button for the forwardmost container snaps into an identical pocket **94** defined within the adjacent side of the body of the module. Clearly, alternative methods of securing the containers in the closed position may be used and are within the scope of this invention. The module is secured within the storage space **15** in the same manner as the preferred embodiment described above.

10 Figs. 14-16 show an alternative embodiment of the invention where the snap-in module comprises a multi-compartment storage container **70** having two identical parallel outer walls **71** which are joined by three rectangular faces. The fourth face **73** is open to provide access to the container. Two integrally molded dividing walls **74** are located within the container to define three equal compartments **75**. The
15 container is rotatably mounted within a recess **90** defined within the body **76** of the module by any suitable means, such as male connection pins **25** projecting outwardly from the outer walls which mate with female connection means (not shown), as described in the preferred embodiment. A handle **51** is defined within the outer face **77**. In the closed position, the outer face of the container is flush with the bottom surface
20 of the box portion **1**, and in the open position, the open face is rotated away from the box portion to allow the user access to the contents of the compartments. The container **70** is secured in the closed position by a plastic clasp configuration **35** snapped onto a plastic member **39**, as described in the preferred embodiment. The module is secured within the storage space **15** in the same manner as the preferred embodiment
25 described above.

Figs. 17 and 18 show an alternative embodiment of the invention where the snap-in module **8** comprises three storage shelves **80** molded to a door **81** which is rotatably connected to the body **82** of the module by a conventional hinge **83**. It will be understood by those skilled in the art that any number of shelves may be molded to
30 the door, and such variations are within the scope of this invention. A recess **90** within the body accommodates the shelves when the door is in the closed position. The door is secured to the storage container by a plastic clasp configuration **35** snapped onto a

plastic member **39**, as described in the preferred embodiment, such that when the door is in the closed position it is flush with the bottom surface of the box portion. The module is snapped into the storage space **15** in the same manner as the preferred embodiment described above.

5 It should be clear to those skilled in the art that the storage space and the snap-in module **8** securable within same can extend over the entire surface the bottom surface of the box portion, or alternatively, it could occupy only a section of the bottom surface of the box portion, and such variations are clearly within the scope of this invention.

10 Fig. 19 shows a preferred embodiment of the invention where the snap-in module **8**, as described in the above embodiments detailing outside snap-in modules, is snapped into a recess **90** defined within the side or a lid of a tool box **91**. The module is snapped into the recess in the same manner as described in the preferred embodiment above. There may be multiple recesses, defined in inner and/or outer
15 surfaces of the box portion and/or the lid, substantially as has been described in conjunction with the earlier described embodiments.

Fig. 20 shows a further embodiment of the invention where a snap-in module **8'**, as described above, is snapped inside a further tool box **100**, having no external snap-in modules. The further tool box has a bottom portion **101** with a handle
20 portion **103**, a lid portion **102** with a handle portion **104**, and a locking mechanism **107** for securing the lid portion against the bottom portion. Further, at least a first tool holding recess **105** and a second tool holding recess **106** are arranged in a top surface of the bottom portion of the tool box.

Figs. 21 to 23 show another embodiment of the invention where plural
25 snap-in modules **8''** are arranged inside a tool box **200**. The modules are as described in conjunction with Figs. 5 and 6 above. The tool box **200** preferably has a handle **201**, a bottom portion **202** and a lid portion **203**. The modules **8''** are arranged to be held in a recess **19'**. Preferably, tool holders **110**, **111** are arranged inside the tool box, in areas not occupied by the recess **19'**. Further technical features of the modules have the
30 same reference numerals as described in conjunction with Figs. 5 and 6.

Figs. 24 to 26 show a further embodiment of the invention where plural snap-in modules **8'''** are arranged inside a tool box **200'**. The modules are as described

in conjunction with Figs. 5 and 6 above. The tool box **200'** preferably has a handle **201'**, a bottom portion **202'** and a lid portion **203'**. The modules **8'''** are arranged to be held in a recess **19''**. Preferably, tool holders (not shown) are arranged inside the tool box, in areas not occupied by the recess **19''**. Further technical features of the modules have the same reference numerals as described in conjunction with Figs. 5 and 6.

Figs. 27 to 29 show yet another embodiment of the invention where plural snap-in modules **8^{IV}** are arranged to slide inside a tool box **200''**. The modules are preferably as described in conjunction with Figs. 5 and 6 above. The tool box **200''** preferably has a handle **201'''**, a bottom portion **202''** and a lid portion (not shown). The modules **8^{IV}** are arranged to be held in removable holder **20**, which is slidably mountable in the tool box on slide rails **210**. The slide rails are arranged on an inner surface of the tool box. Preferably, tool holders (not shown) are arranged inside the tool box, in areas not occupied by the slide rails **210** or the holder **20** when it is mounted in the tool box. Further technical features of the modules have the same reference numerals as described in conjunction with Figs. 5 and 6.

In general, selected technical features relating to the individual modules and their fastening to the tool box described in relation to Figs. 1 to 18 also relate to the fastening and arrangement of modules inside the tool box, as described in conjunction to Figs. 19 to 29.

It will be appreciated that the above description relates to the preferred embodiment by way of example only. Many variations on the invention will be obvious to those knowledgeable in the field, and such obvious variations are within the scope of the invention as described and claimed, whether or not expressly described.

THE EMBODIMENTS OF THE INVENTION IN WHICH AN EXCLUSIVE PROPERTY OR PRIVILEGE IS CLAIMED ARE DEFINED AS FOLLOWS:

1. A tool case comprising:
 - a box portion;
 - 5 a lid pivotably connected to said box portion;
 - a storage space defined within the inside surface of said box portion; and
 - at least one storage module securable within said storage space.

2. A tool case as recited in claim 1, wherein said storage module is removably securable within said storage space.

- 10 3. A tool case as recited in claim 1, wherein said storage module is non-removably securable within said storage space.

4. A tool case as recited in claim 1, wherein said storage space further comprises an opening defined within said inside surface of said box portion and a plurality of integrally molded interior walls projecting upwardly from said opening.

- 15 5. A tool case as defined in claim 4, wherein said at least one module further comprises:
 - at least one tab projecting outwardly from a first side of said module;
 - an arm flexibly connected to a second side of said module;
 - a jaw defined within the distal end of said arm;
 - 20 and said tool case further comprises;
 - at least one slit defined within one of said interior walls adjacent to said first side of said module;
 - a lip protruding from one of said interior walls adjacent to said second side of said module;
 - 25 whereby said module may be secured within said storage space by inserting said at least one tab projecting from said module into said slit defined within said interior wall, and said jaw defined within the distal end of said arm engages said lip.

6. A tool case as defined in claim 1, wherein said at least one module further comprises:

a module body;

a recess defined within said module body;

5 a plurality of containers pivotably mounted inside said recess connected along at least one side by a gang bar, said containers configured to pivot in unison between open and closed positions, such that in said closed position, an outer face of each said container is coplanar and flush with said inner surface of said box portion, and in said open position, said outer face projects outwardly, exposing openings into
10 said containers.

7. A tool case as defined in claim 1, wherein said at least one module further comprises:

a module body;

a recess defined within said module body to form a storage container; and

15 a door pivotably connected to said body.

8. A tool case as defined in claim 1, wherein said at least one module further comprises:

a module body;

a recess defined within said module body;

20 a plurality of drawers slidably mounted within said recess.

9. A tool case as defined in claim 1, wherein said at least one module further comprises:

a module body;

a recess defined within said module body;

25 a plurality of wedge-shaped storage containers pivotably mounted within said recess, said containers configured to pivot individually between open and closed positions, such that in said closed position, an outer face of each said container is coplanar and flush with said inner surface of said box portion, and in said open position, said outer face projects outwardly, exposing openings into said containers.

10. A tool case as defined in claim 1, wherein said at least one module further comprises:

a module body;

a recess defined within said module body;

5 a multi-compartment storage container comprising:

three integral rectangular faces;

two integral identical parallel four-sided outer walls joining said three rectangular faces;

an open fourth face to provide access to said container; and

10 two integral dividing walls defining three storage compartments;

said container pivotably mounted within said recess, said container configured to pivot between open and closed positions, such that in said closed position, an outer face of said container is coplanar and flush with said inner surface of said box portion, and in said open position, said outer face projects outwardly, exposing opening into said compartments.

11. A tool case as defined in claim 1, wherein said at least one module further comprises:

a module body;

a recess defined within said module body;

20 a door pivotably connected to said body; and

a plurality of integrally molded shelves projecting outwardly from the inner face of said door;

said door configured to pivot between open and closed positions, such that in said closed position, an outer face of said door is coplanar and flush with said inner surface of said box portion, and in said open position, said outer face projects outwardly, exposing said shelves.

12. A tool case as defined in claim 5, wherein said at least one module further comprises:

a module body;

30 a recess defined within said module body;

a plurality of containers pivotably mounted inside said recess connected along at least one side by a gang bar, said containers configured to pivot in unison between open and closed positions, such that in said closed position, an outer face of each said container is coplanar and flush with said inner surface of said box portion, and in said open position, said outer face projects outwardly, exposing openings into said containers.

5 13. A tool case as defined in claim 5, wherein said at least one module further comprises:

a module body;

10 a recess defined within said module body to form a storage container; and a door pivotably connected to said body.

14. A tool case as defined in claim 5, wherein said at least one module further comprises:

a module body;

15 a recess defined within said module body; and

a plurality of drawers slidably mounted within said recess.

15. A tool case as defined in claim 5, wherein said at least one module further comprises:

a module body;

20 a recess defined within said module body;

a plurality of wedge-shaped storage containers pivotably mounted within said recess, said containers configured to pivot individually between open and closed positions, such that in said closed position, an outer face of each said container is coplanar and flush with said inner surface of said box portion, and in said open position, said outer face projects outwardly, exposing openings into said containers.

16. A tool case as defined in claim 5, wherein said at least one module further comprises:

a module body;

a recess defined within said module body;

a multi-compartment storage container comprising:

three integral rectangular faces;

two integral identical parallel four-sided outer walls joining said
5 three rectangular faces;

an open fourth face to provide access to said container; and

two integral dividing walls defining three storage compartments;

said container pivotably mounted within said recess, said container configured to pivot
between open and closed positions, such that in said closed position, an outer face of
10 said container is coplanar and flush with said inner surface of said box portion, and in
said open position, said outer face projects outwardly, exposing opening into said
compartments.

17. A tool case as defined in claim 5, wherein said at least one module further
comprises:

15 a module body;

a recess defined within said module body;

a door pivotably connected to said body; and

a plurality of integrally molded shelves projecting outwardly from the inner
face of said door;

20 said door configured to pivot between open and closed positions, such that in said
closed position, an outer face of said door is coplanar and flush with said inner surface
of said box portion, and in said open position, said outer face projects outwardly,
exposing said shelves.

18. A tool case comprising:

25 a large box portion;

a lid pivotably connected to said box portion;

multiple tool and component storage spaces defined within interior or
exterior surfaces of said box portion and said lid; and

30 at least one storage module securable within at least one of said storage
spaces.

19. A tool case as recited in claim 19, wherein said storage module is removably securable within said storage space.

20. A tool case as recited in claim 19, wherein said storage module is non-removably securable within said storage space.

5 21. A tool case comprising a box portion defining a main storage area, a lid pivotally connected to said box portion, a recess defined in at least one interior surface of said tool case, and at least one removable module, each removable module being removably securable in said recess and configured to provide a secondary storage area, said at least one removable module having a plurality of separate storage
10 compartments accessible when said at least one removable module is secured in said recess.

22. A tool case as recited in claim 21, wherein one of said compartments is pivotable relative to said module, between open and closed positions.

15 23. A tool case as recited in claim 22, such that in said closed position, an outer face of each of said compartments is coplanar and flush with one said interior surface in which said recess is defined.

24. A tool case as recited in claim 22, wherein there are plural said compartments pivotable relative to their module, between open and closed positions.

20 25. A tool case as recited in claim 24, such that in said closed position, an outer face of each of said compartments is coplanar and flush with one said interior surface in which said recess is defined.

26. A tool case as recited in claim 24, wherein said compartments are ganged together for ganged movement between said open and closed positions.

27. A tool case as recited in claim 26, wherein said compartments are ganged

together by virtue of a gang bar connecting each of said compartments.

28. A tool case as recited in claim 27, such that in said closed position, an outer face of each of said compartments is coplanar and flush with said interior surface in which said recess is defined.

5 29. A tool case as recited in claim 26, such that in said closed position, an outer face of each of said pivotable compartments is coplanar and flush with said interior surface in which said recess is defined.

10 30. A tool case comprising a box portion defining a main storage area, a lid pivotally connected to said box portion, a recess defined in at least one exterior surface of said tool case, and at least one non-removable module, each removable module being securable in said recess and configured to provide a secondary storage area, said at least one non-removable module having a plurality of separate storage compartments accessible when said at least one non-removable module is secured in said recess.

15 31. A tool case as recited in claim 30, wherein one of said compartments is pivotable relative to said module, between open and closed positions.

32. A tool case as recited in claim 31, such that in said closed position, an outer face of each of said compartments is coplanar and flush with one said exterior surface in which said recess is defined.

20 33. A tool case as recited in claim 31, wherein there are plural said compartments pivotable relative to their module, between open and closed positions.

34. A tool case as recited in claim 33, such that in said closed position, an outer face of each of said compartments is coplanar and flush with one said exterior surface in which said recess is defined.

35. A tool case as recited in claim 33, wherein said compartments are ganged together for ganged movement between said open and closed positions.

36. A tool case as recited in claim 35, wherein said compartments are ganged together by virtue of a gang bar connecting each of said compartments.

5 37. A tool case as recited in claim 36, such that in said closed position, an outer face of each of said compartments is coplanar and flush with said exterior surface in which said recess is defined.

10 38. A tool case as recited in claim 35, such that in said closed position, an outer face of each of said pivotable compartments is coplanar and flush with said exterior surface in which said recess is defined.

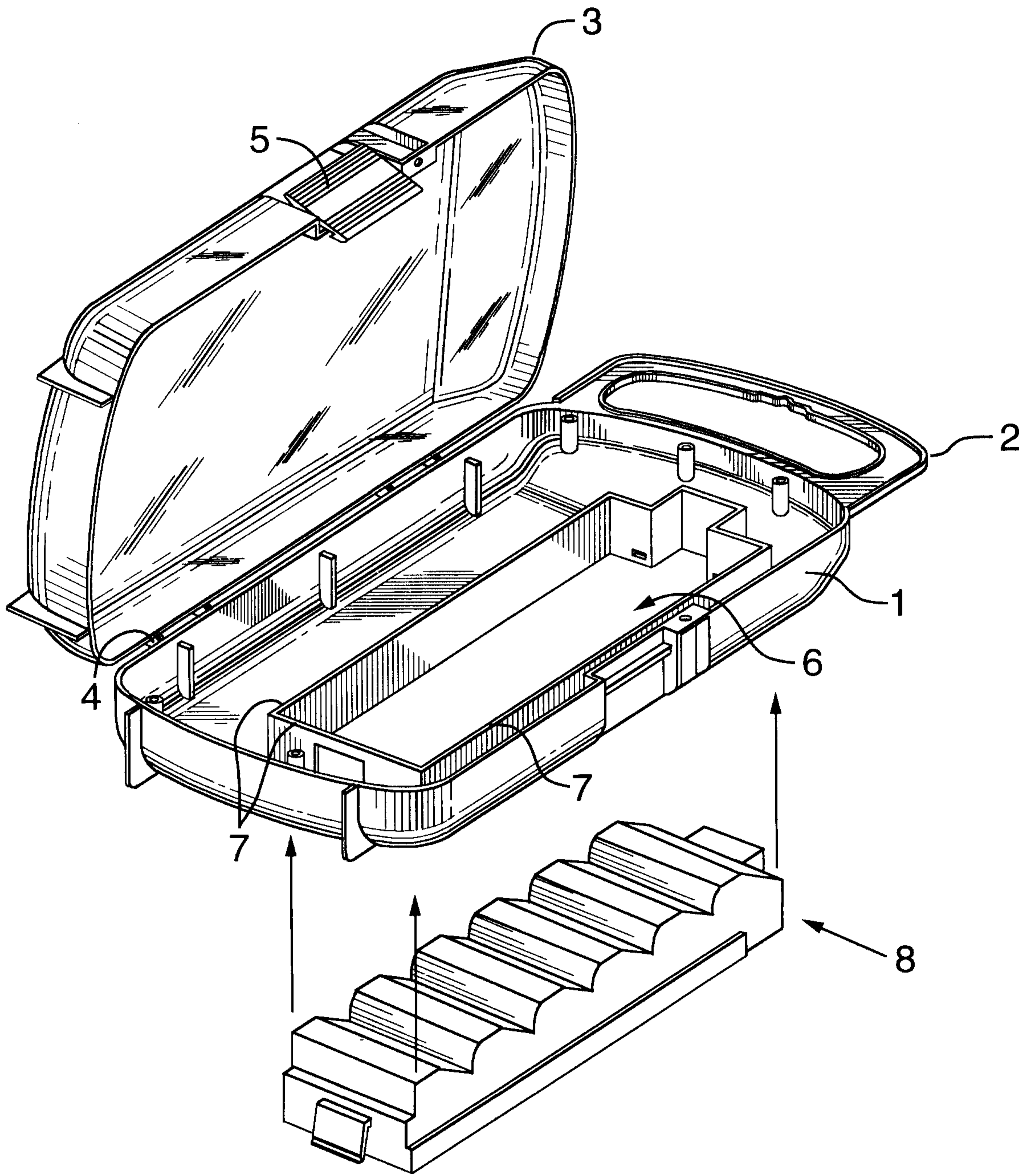

FIG.1

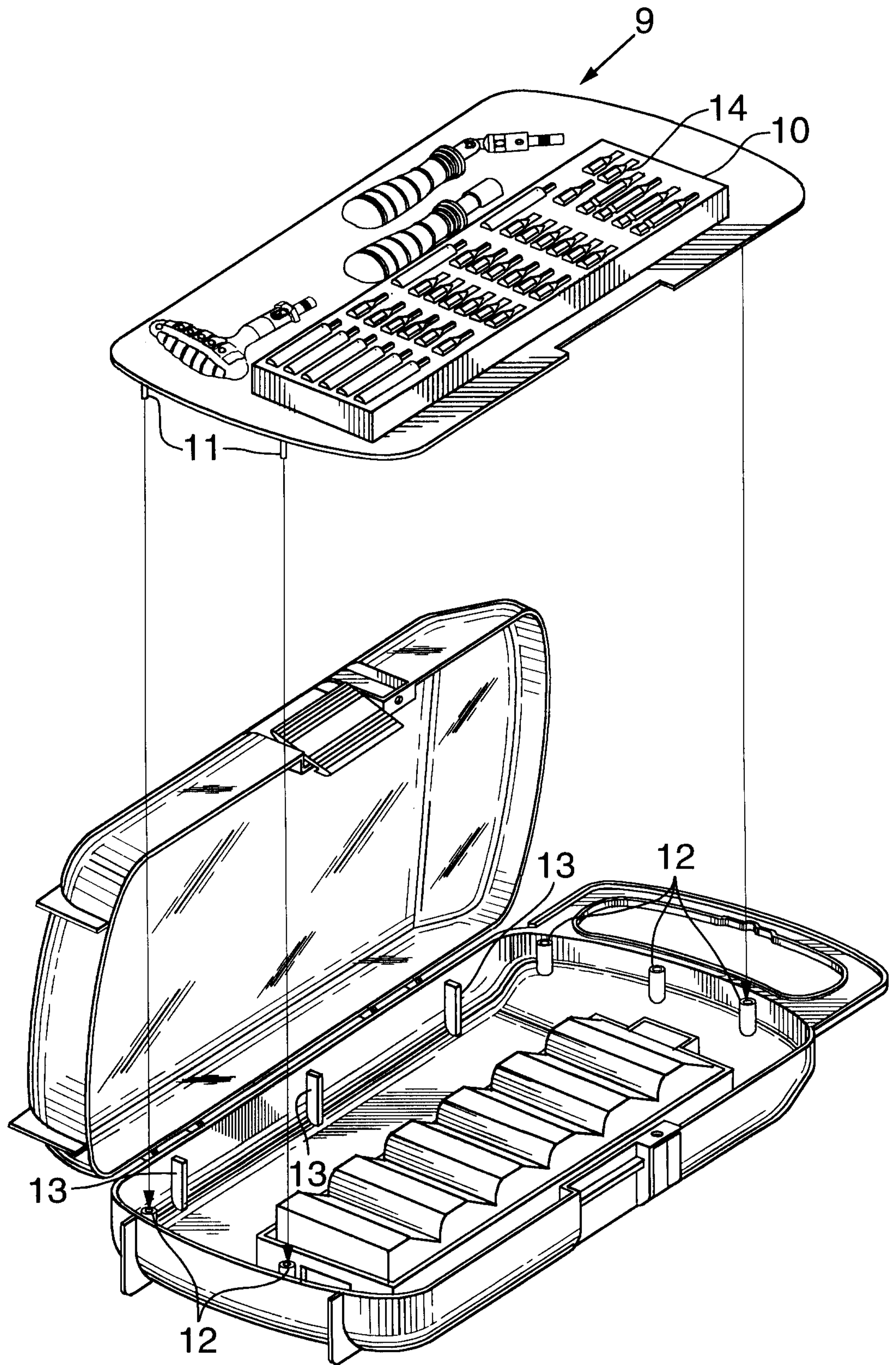

FIG.2

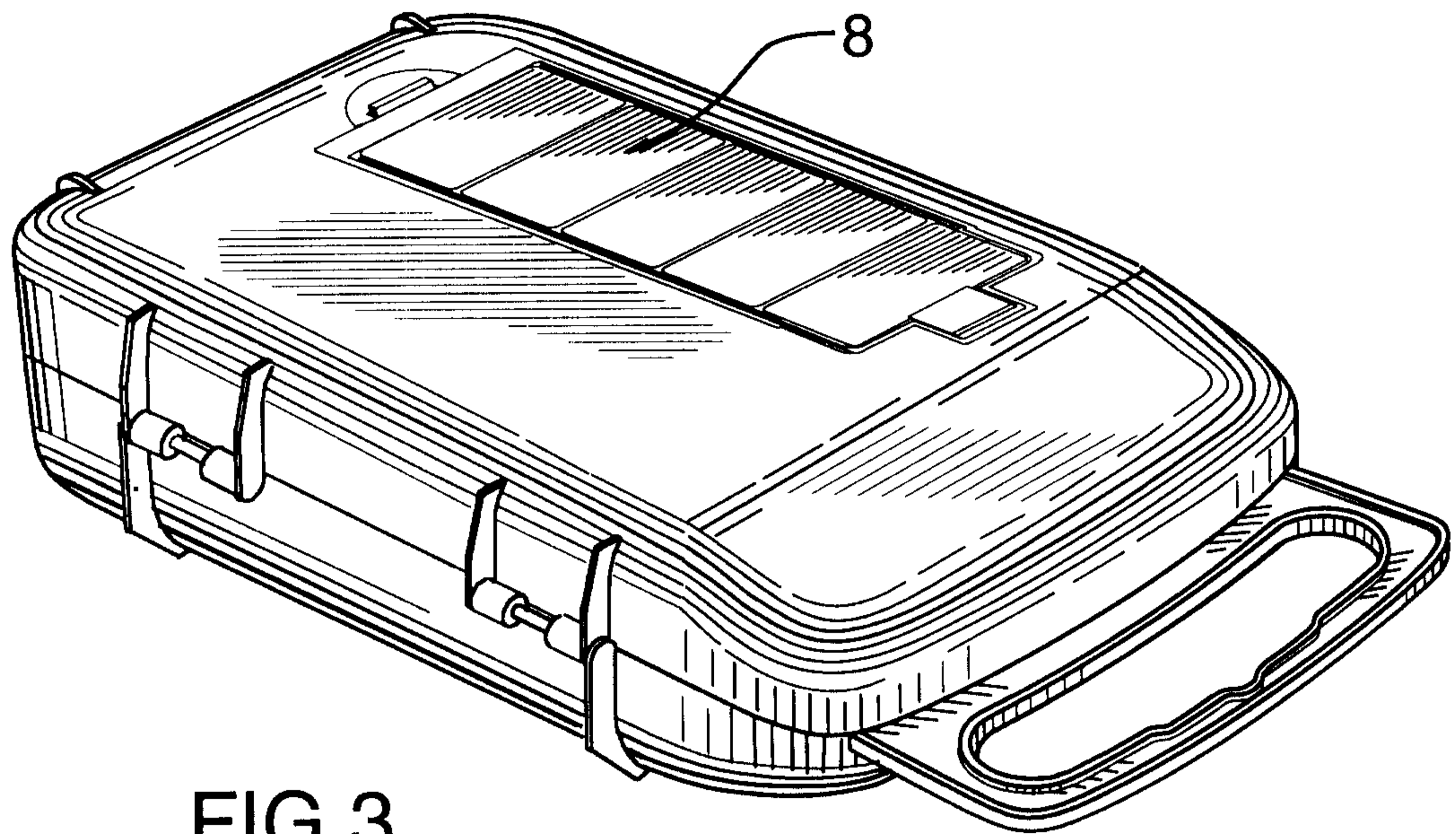

FIG. 3

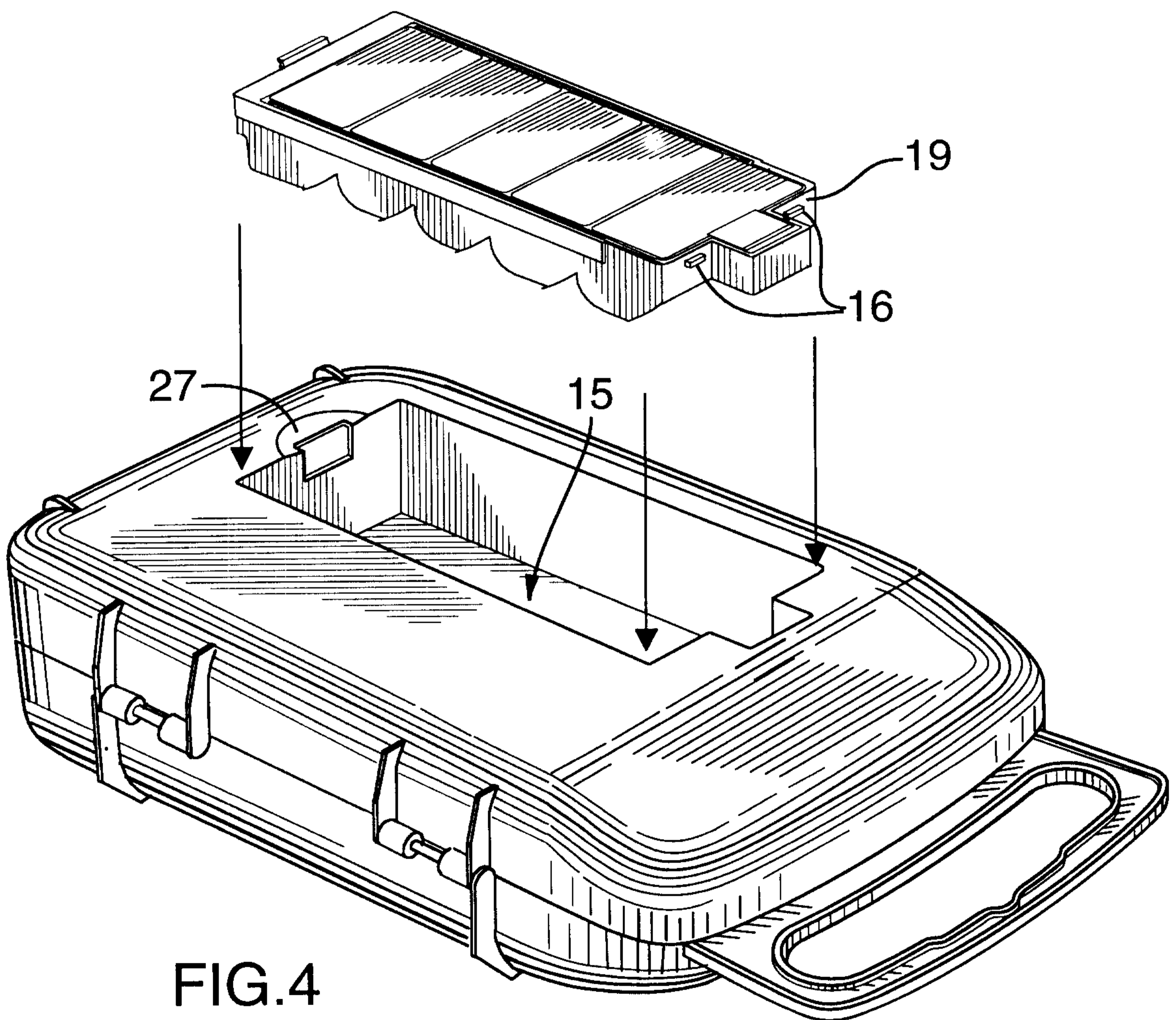

FIG. 4

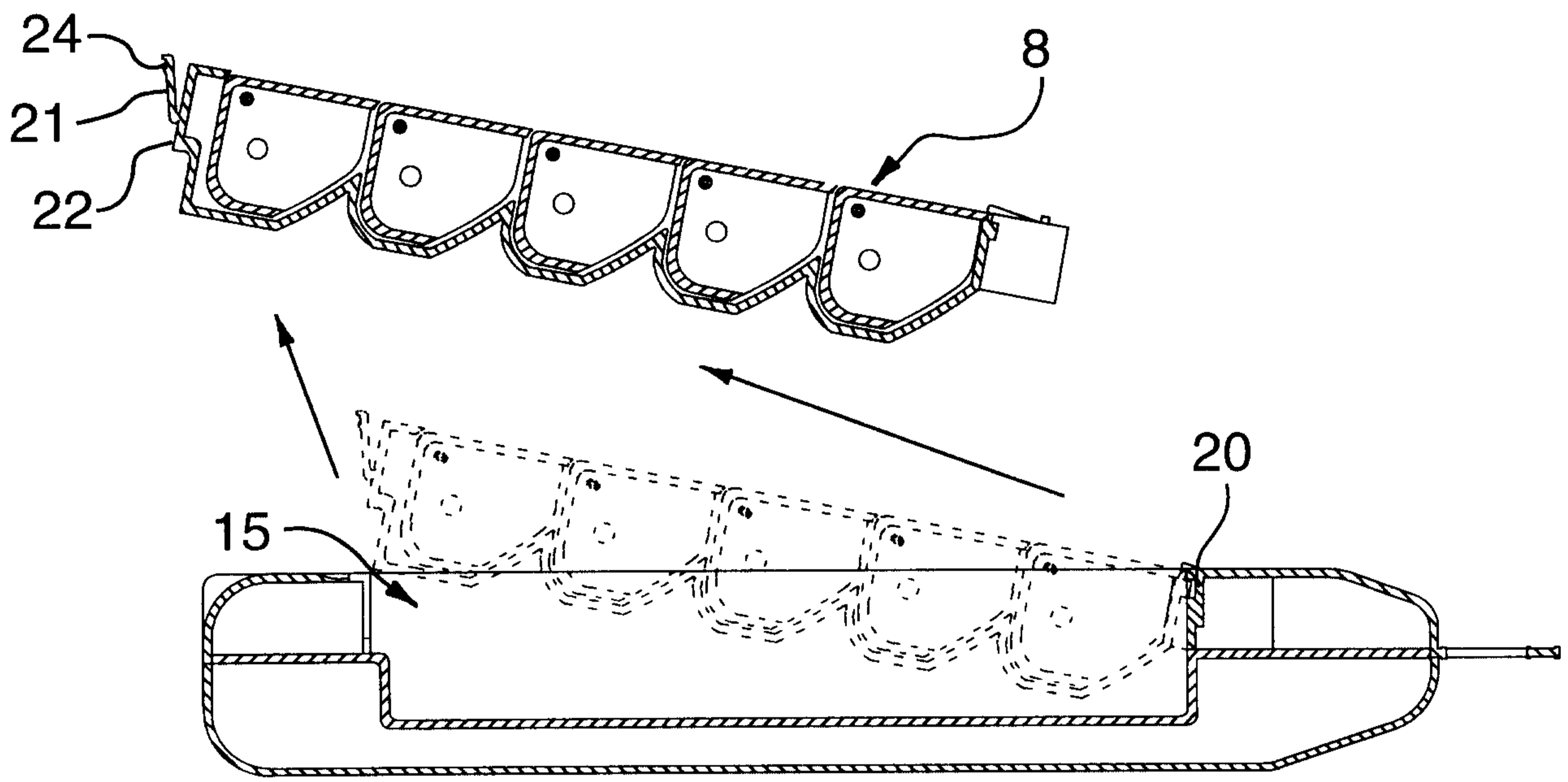

FIG. 5

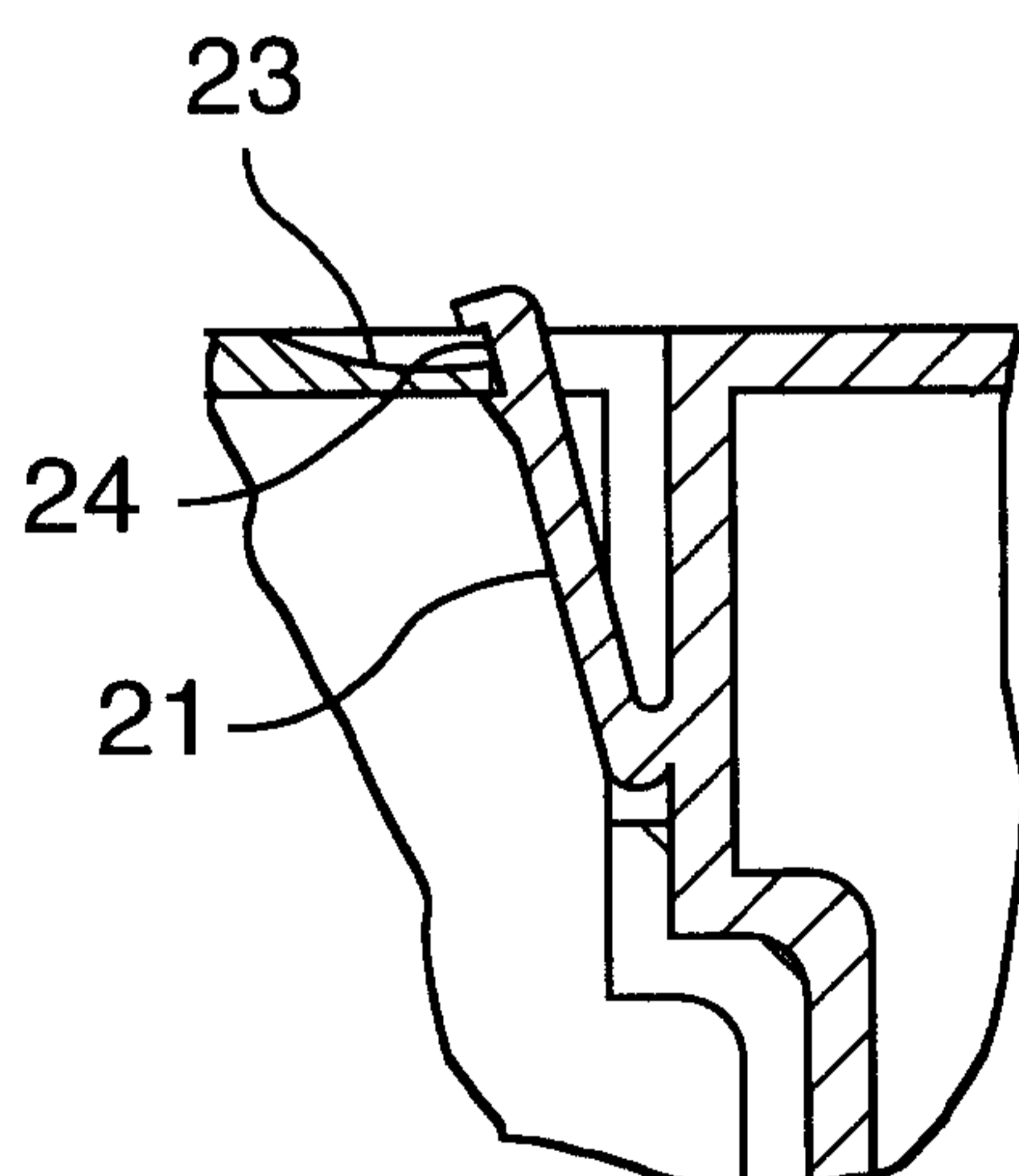

FIG. 5A

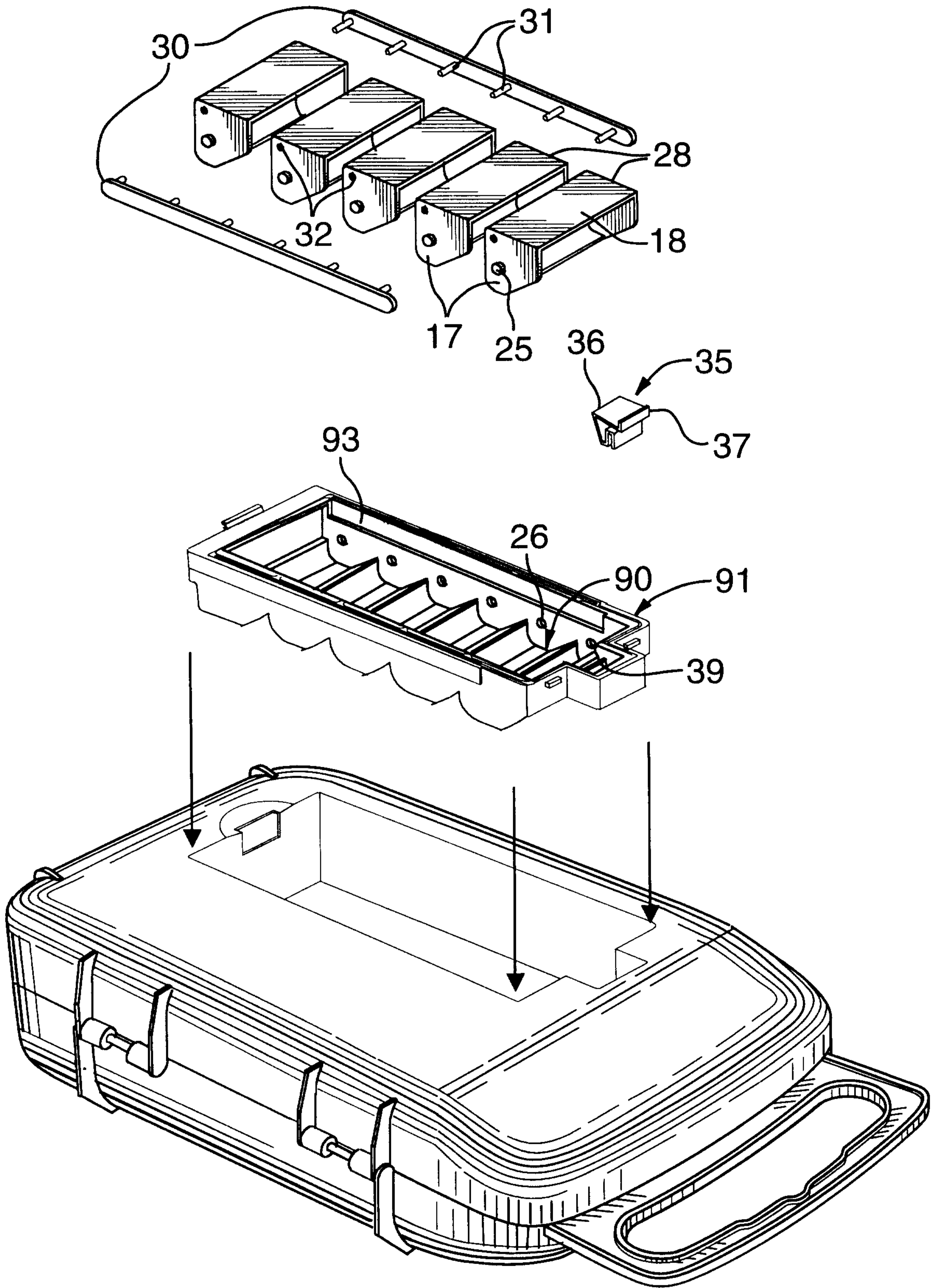

FIG.6

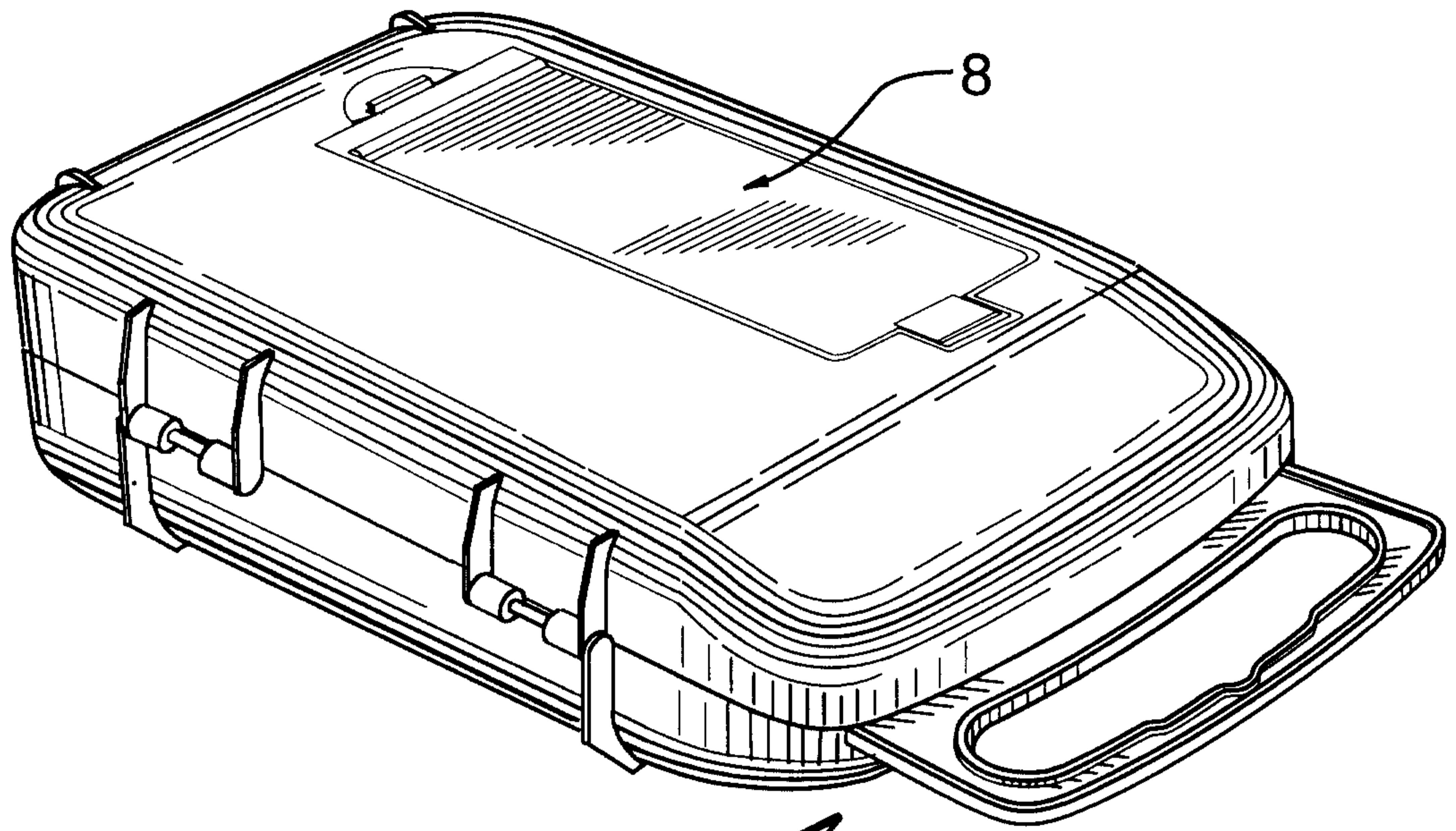

FIG.7

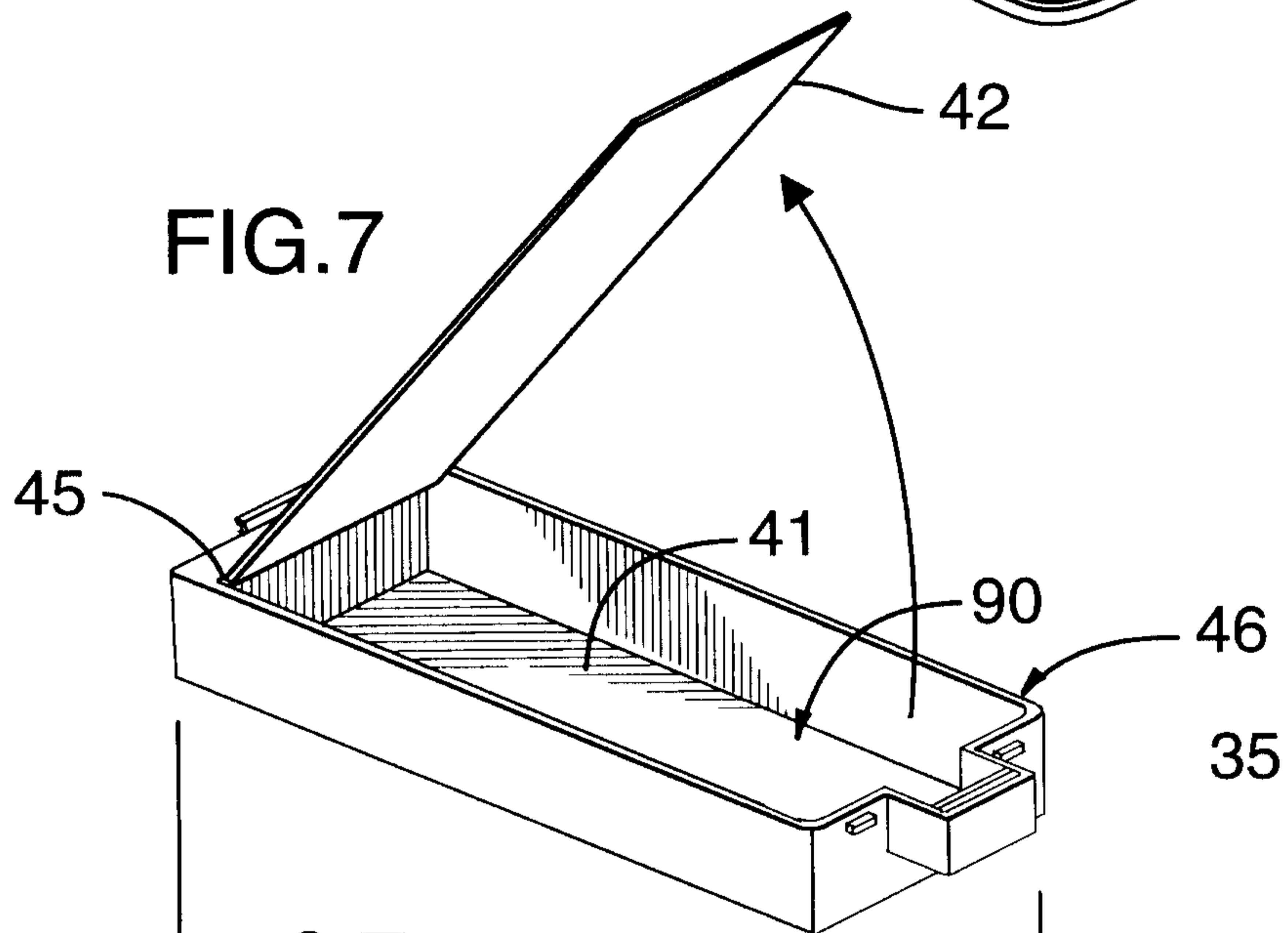

FIG.8

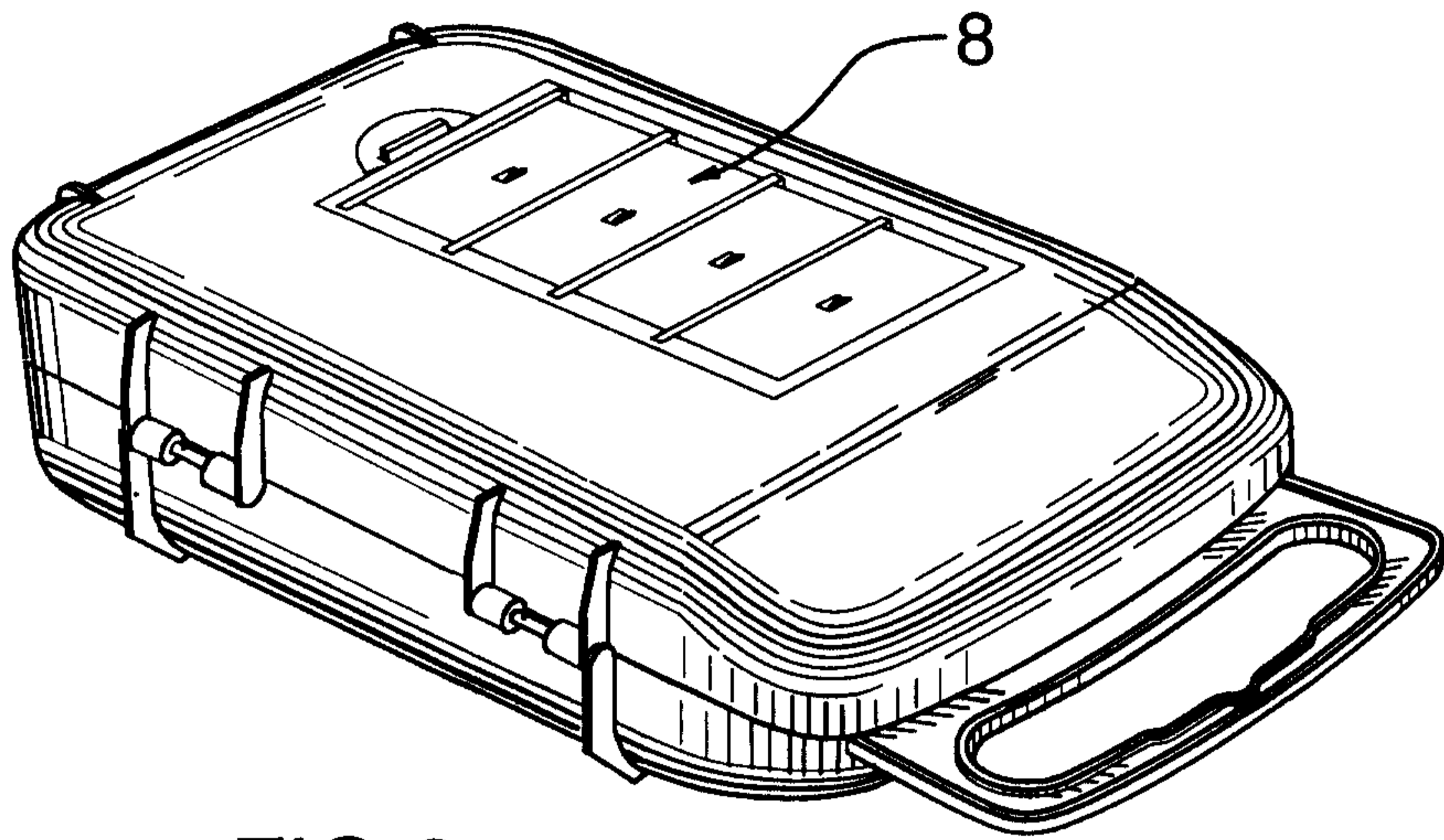

FIG. 9

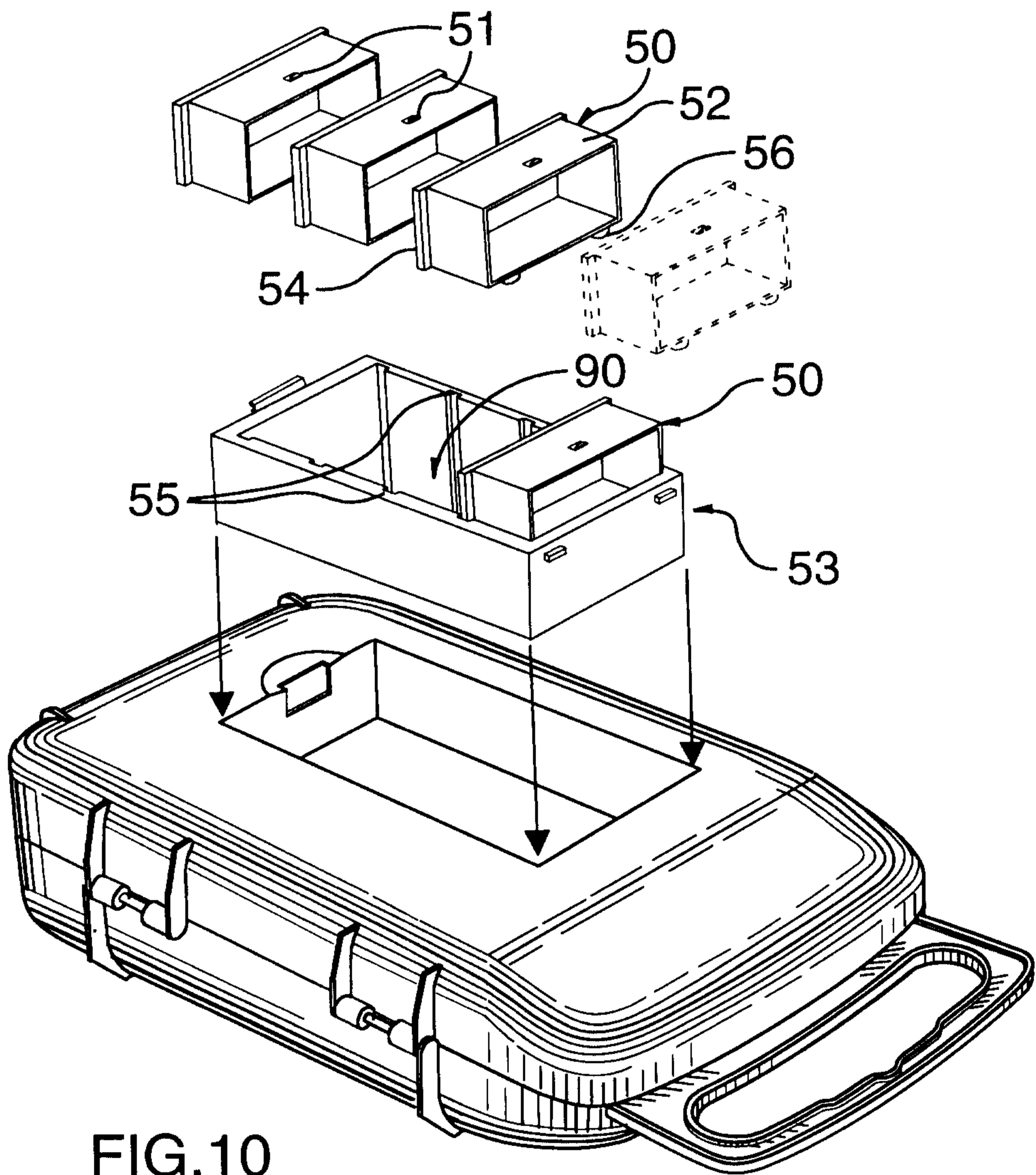
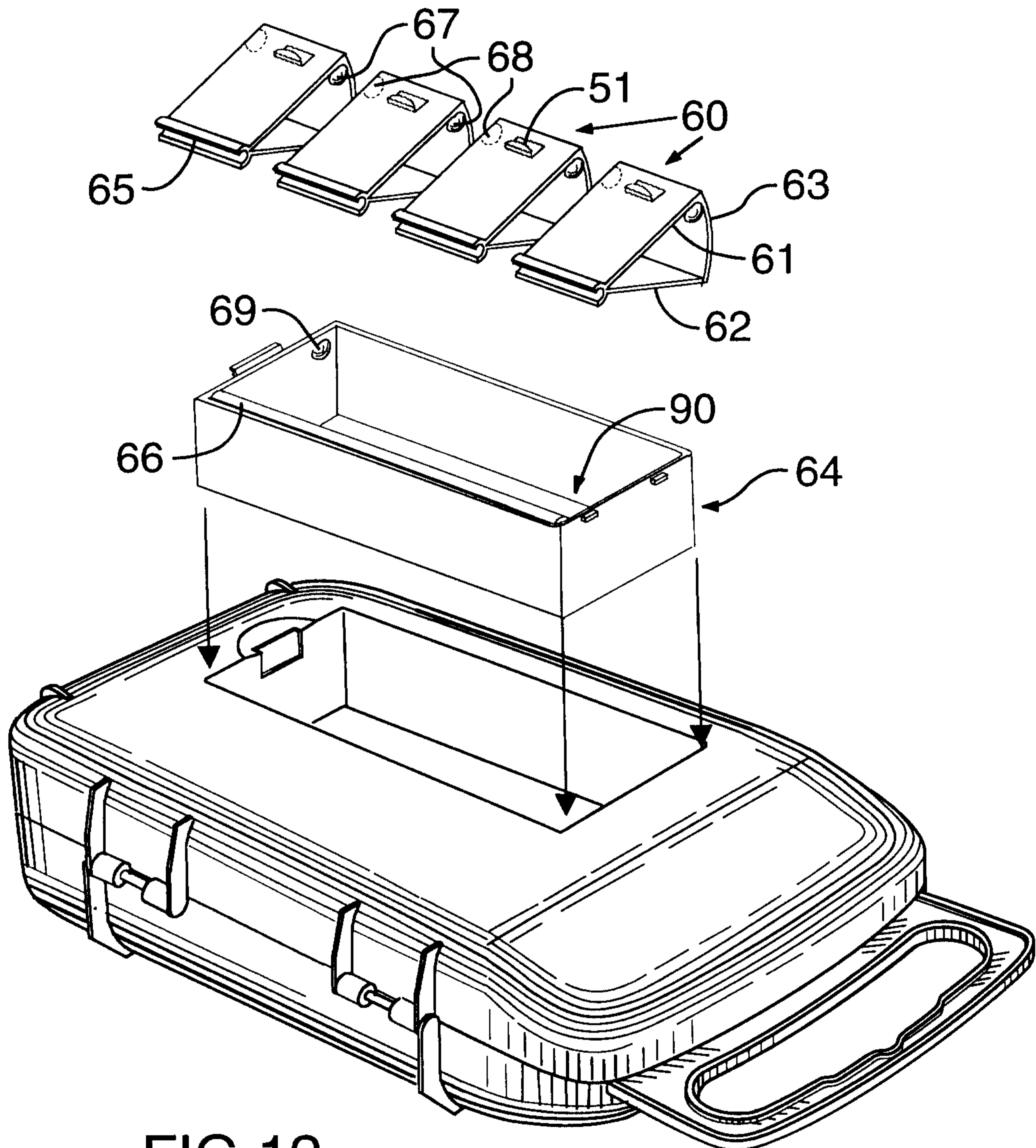
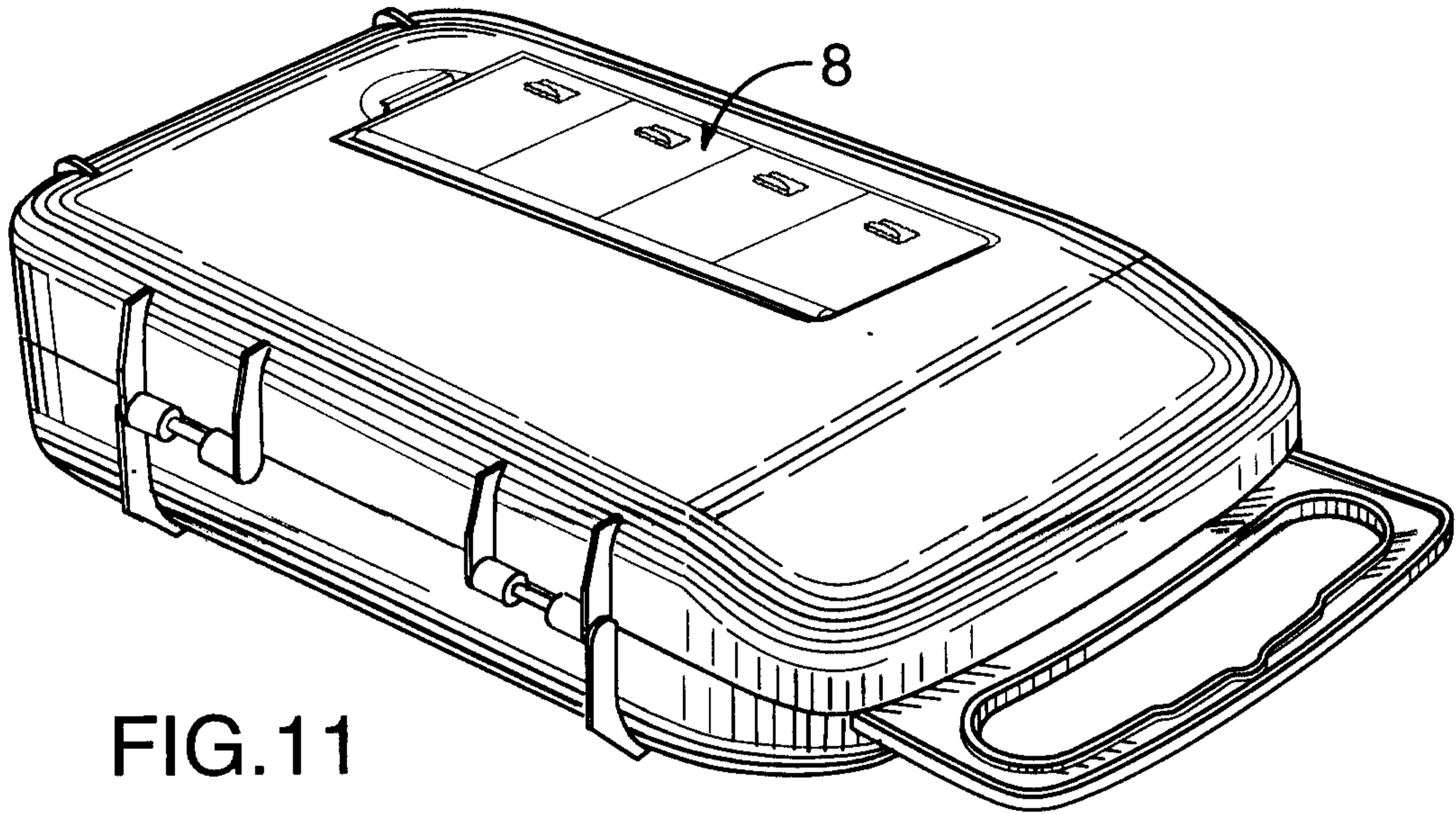

FIG. 10



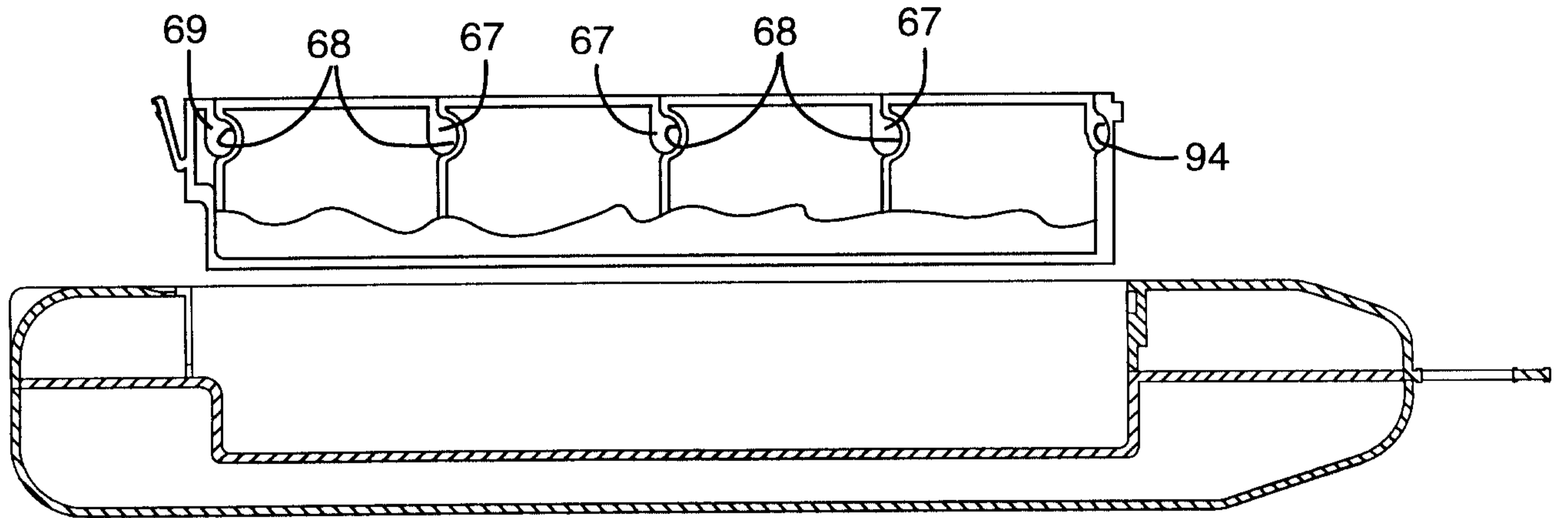

FIG. 13

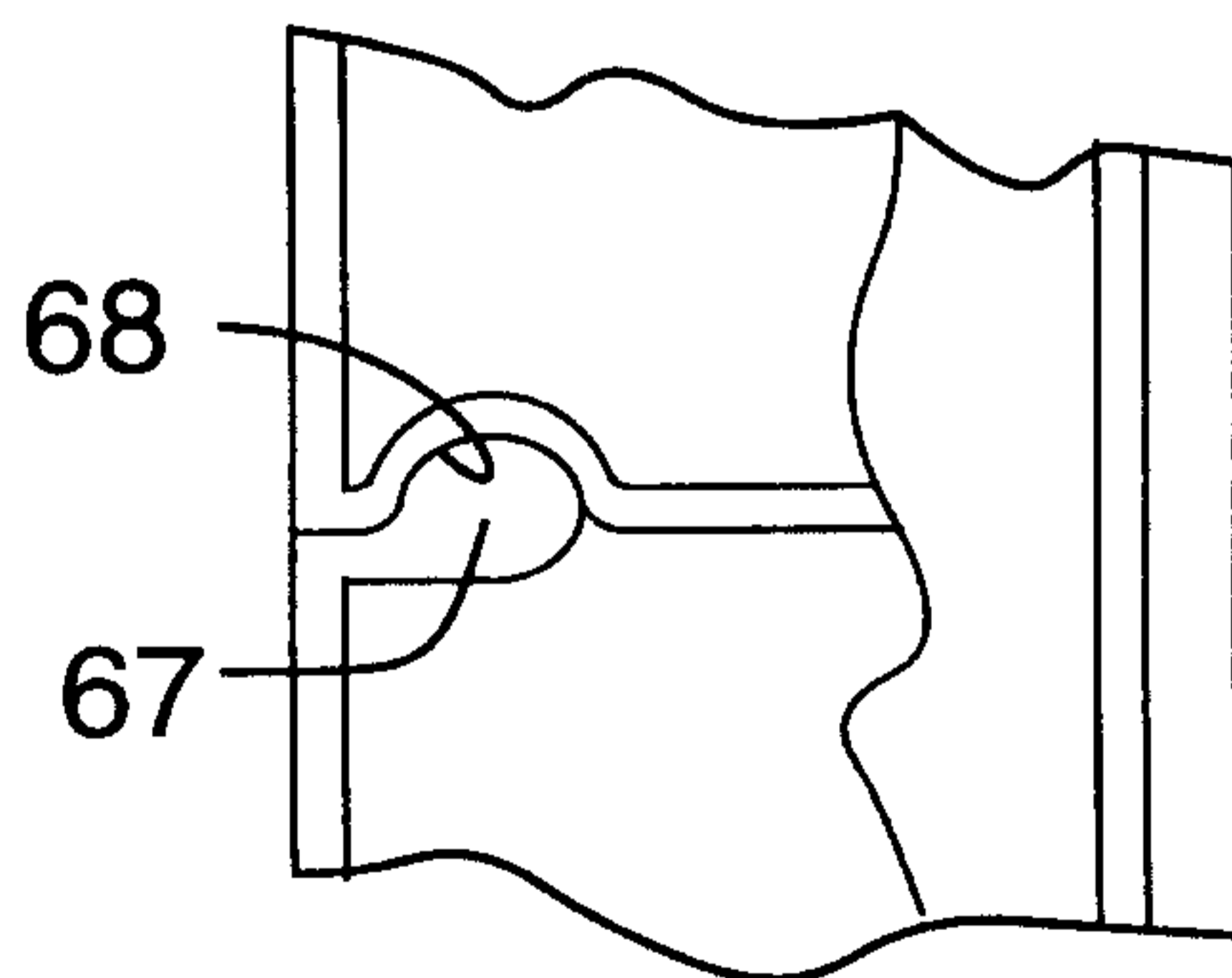

FIG. 13A

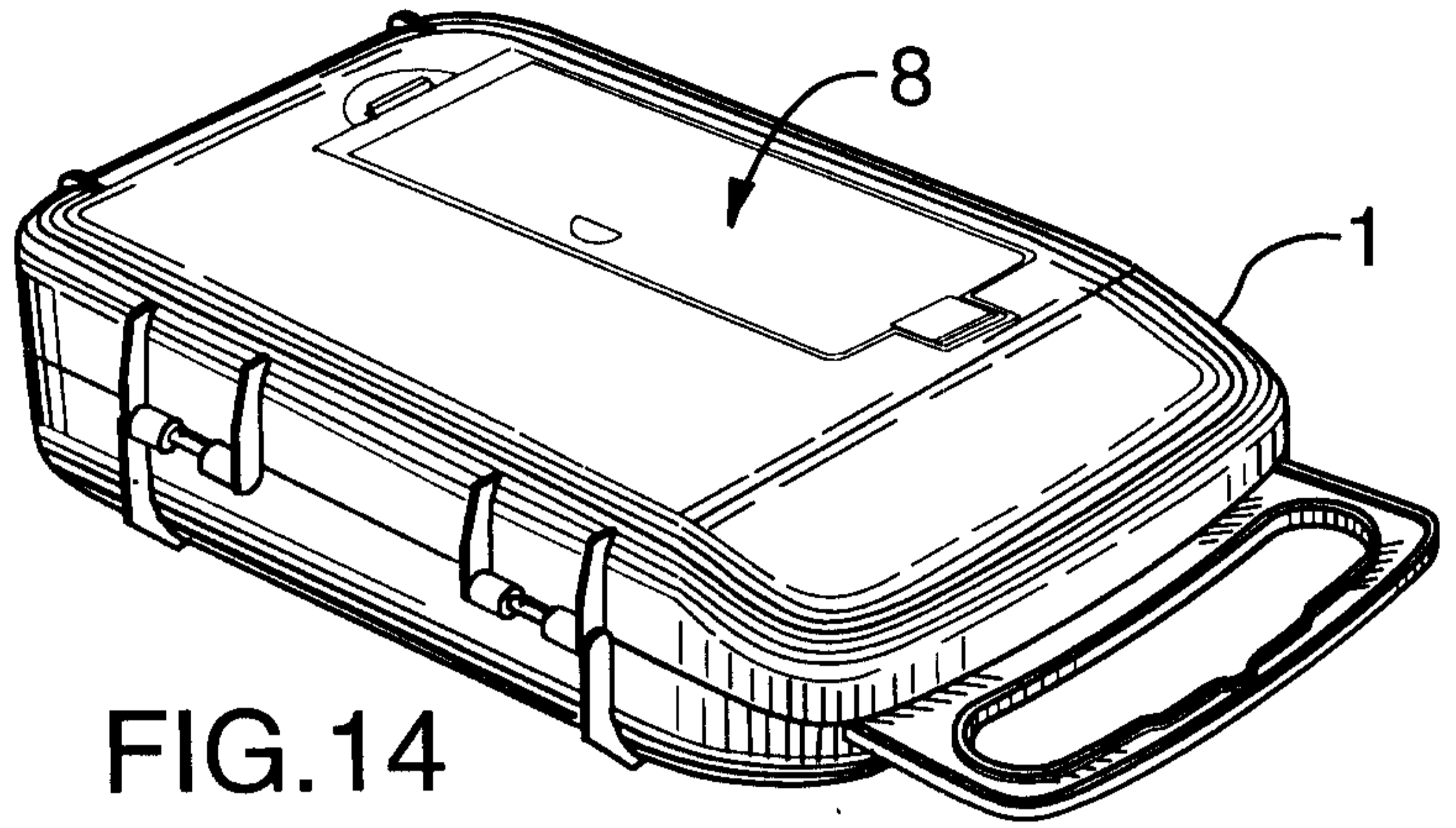

FIG. 14

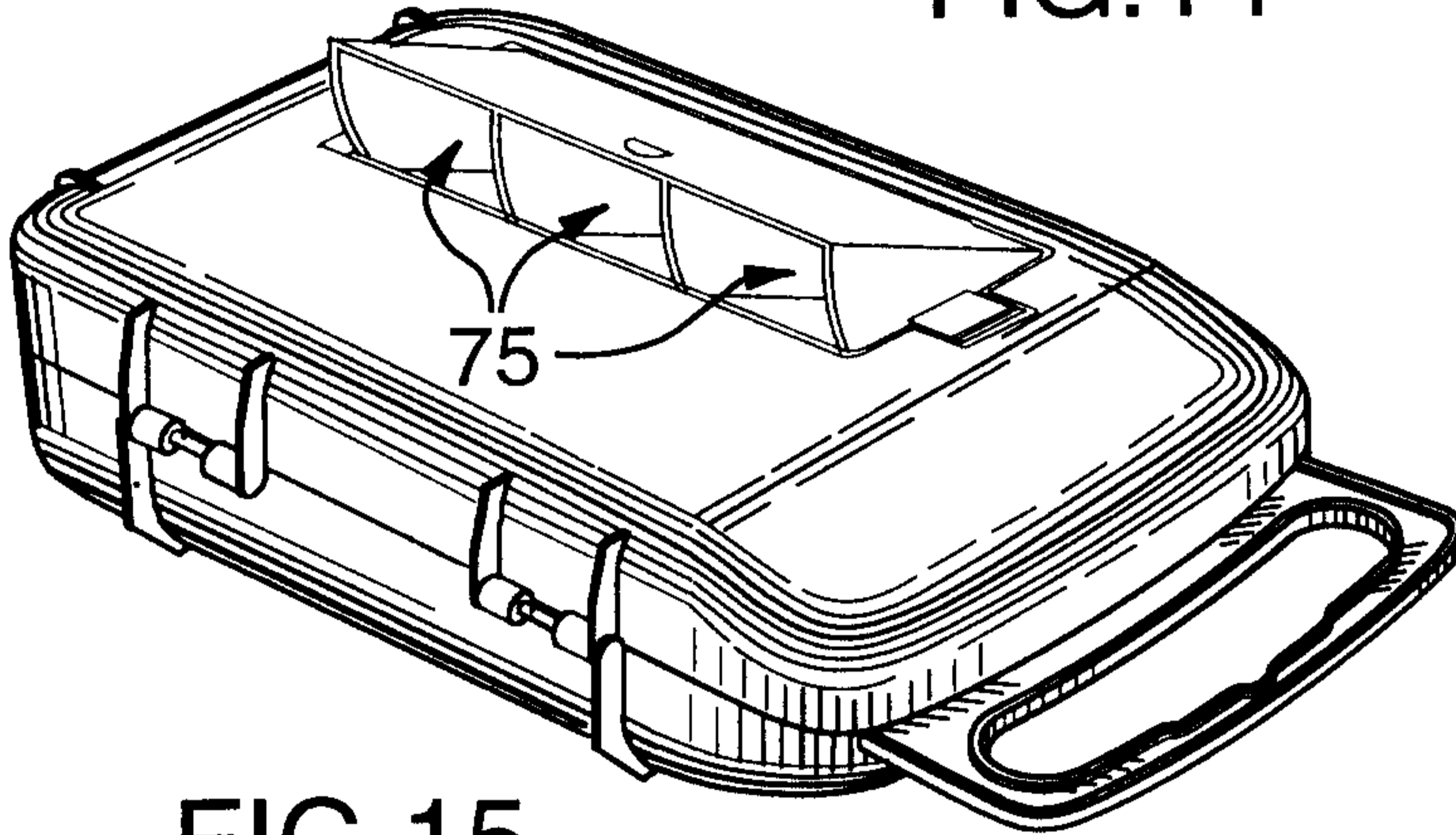

FIG. 15

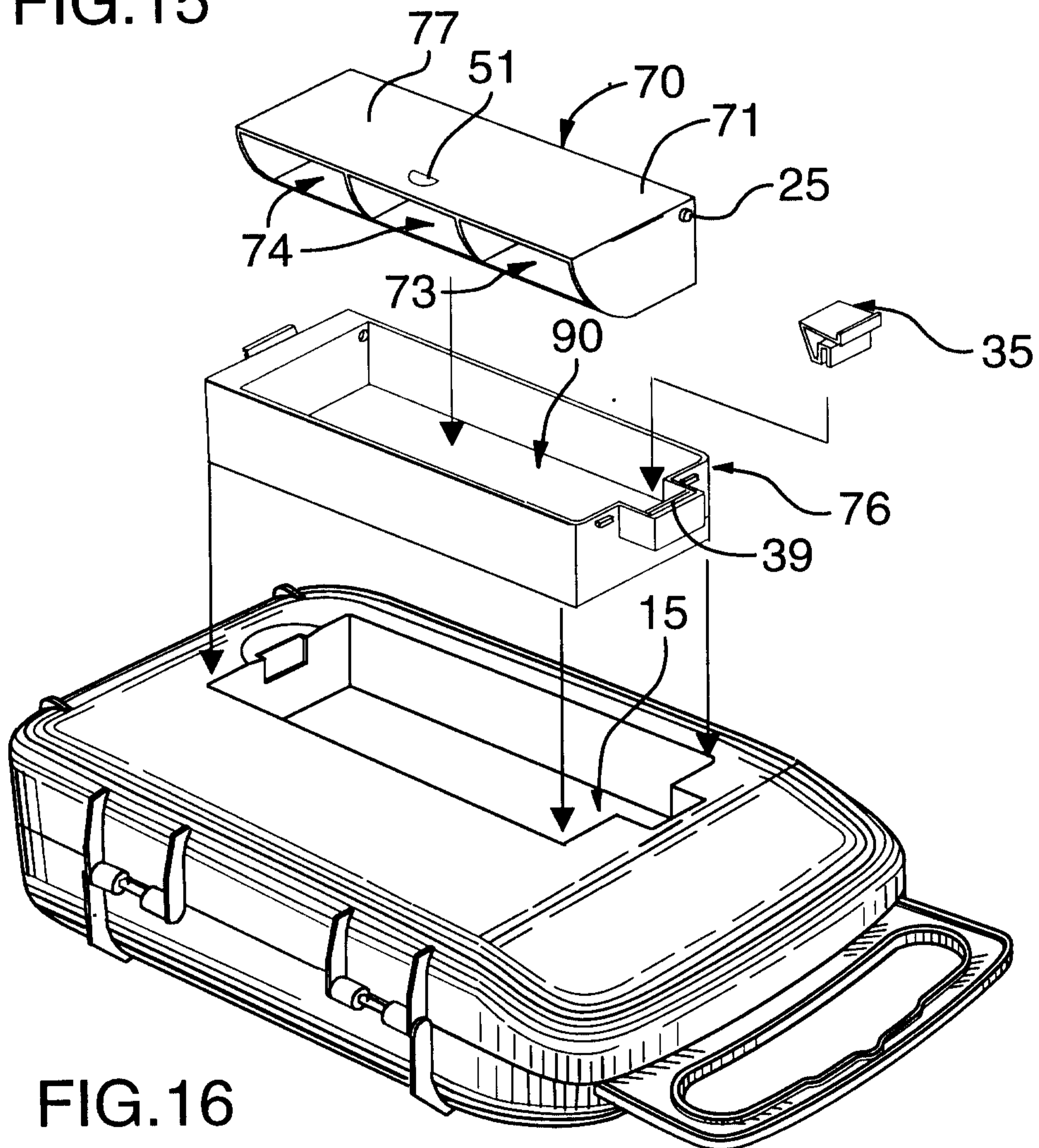
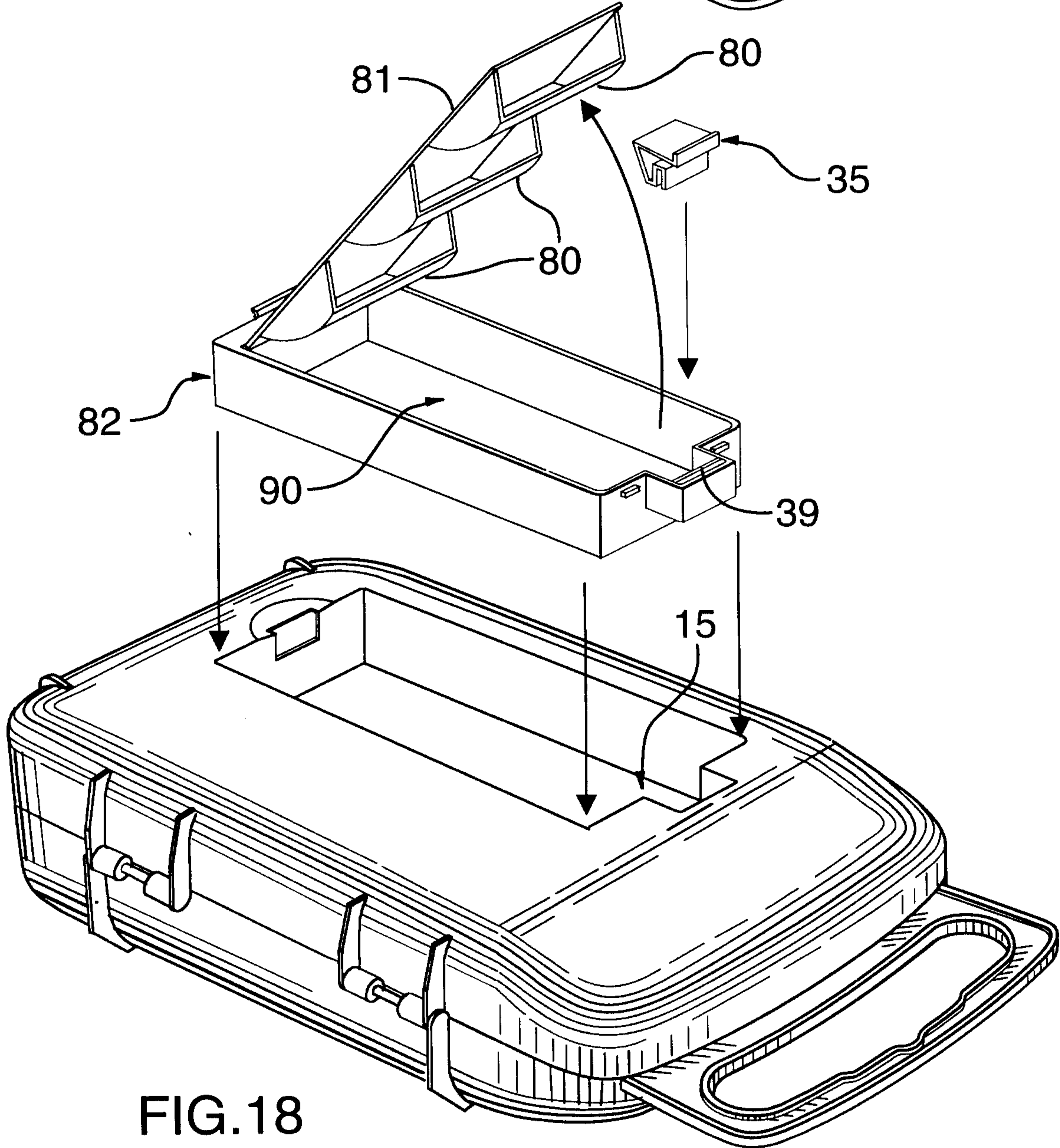
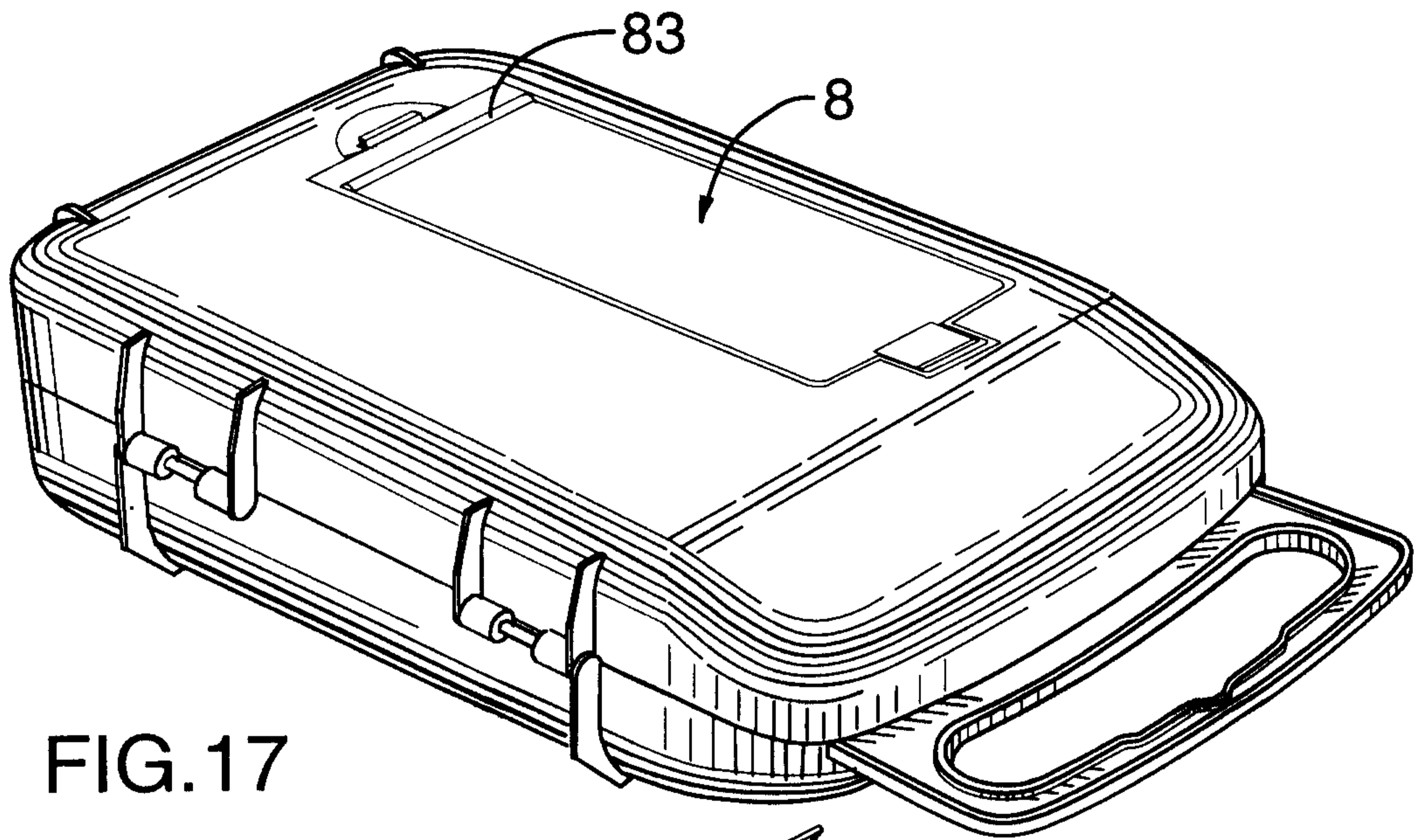

FIG. 16



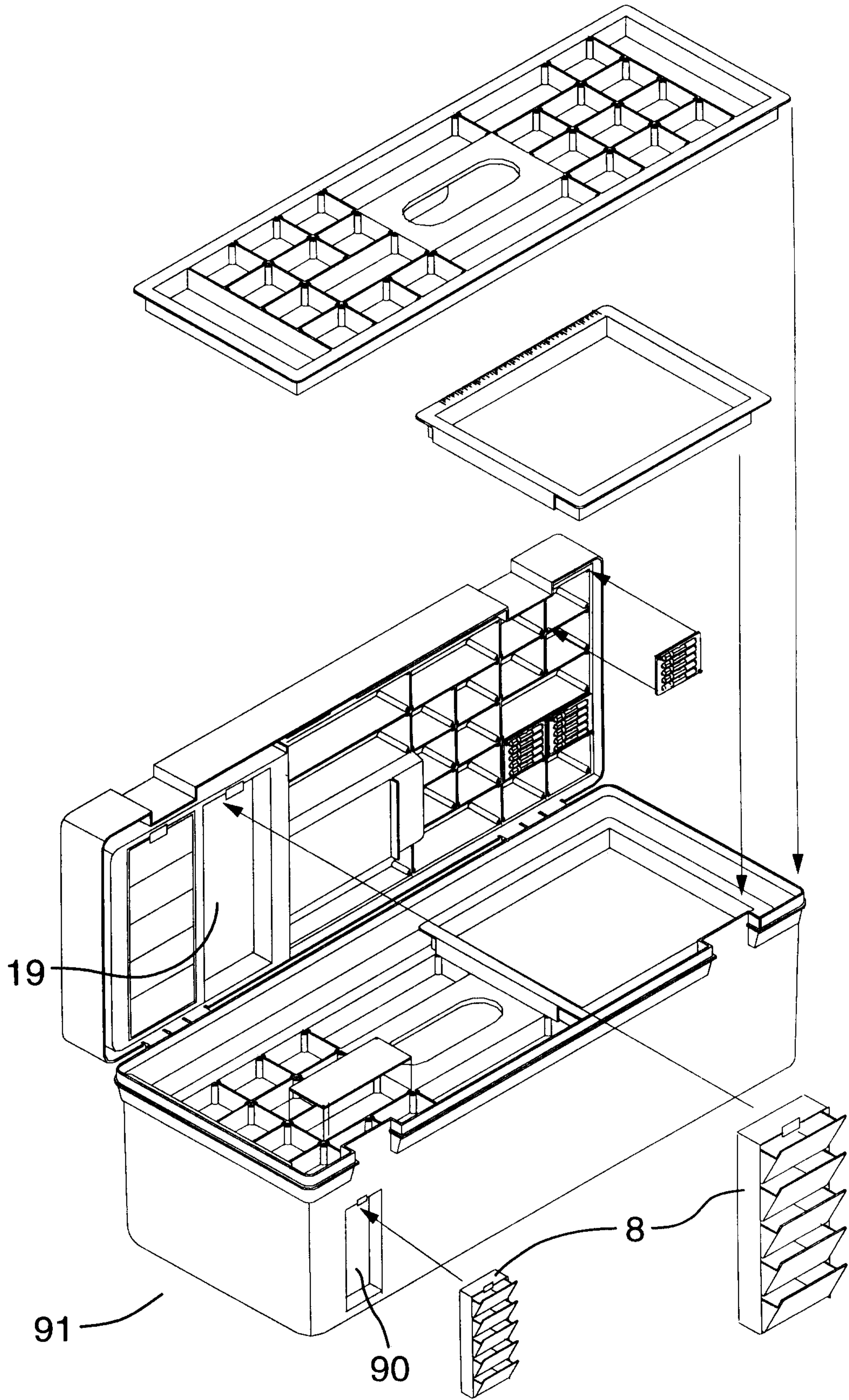

FIG.19

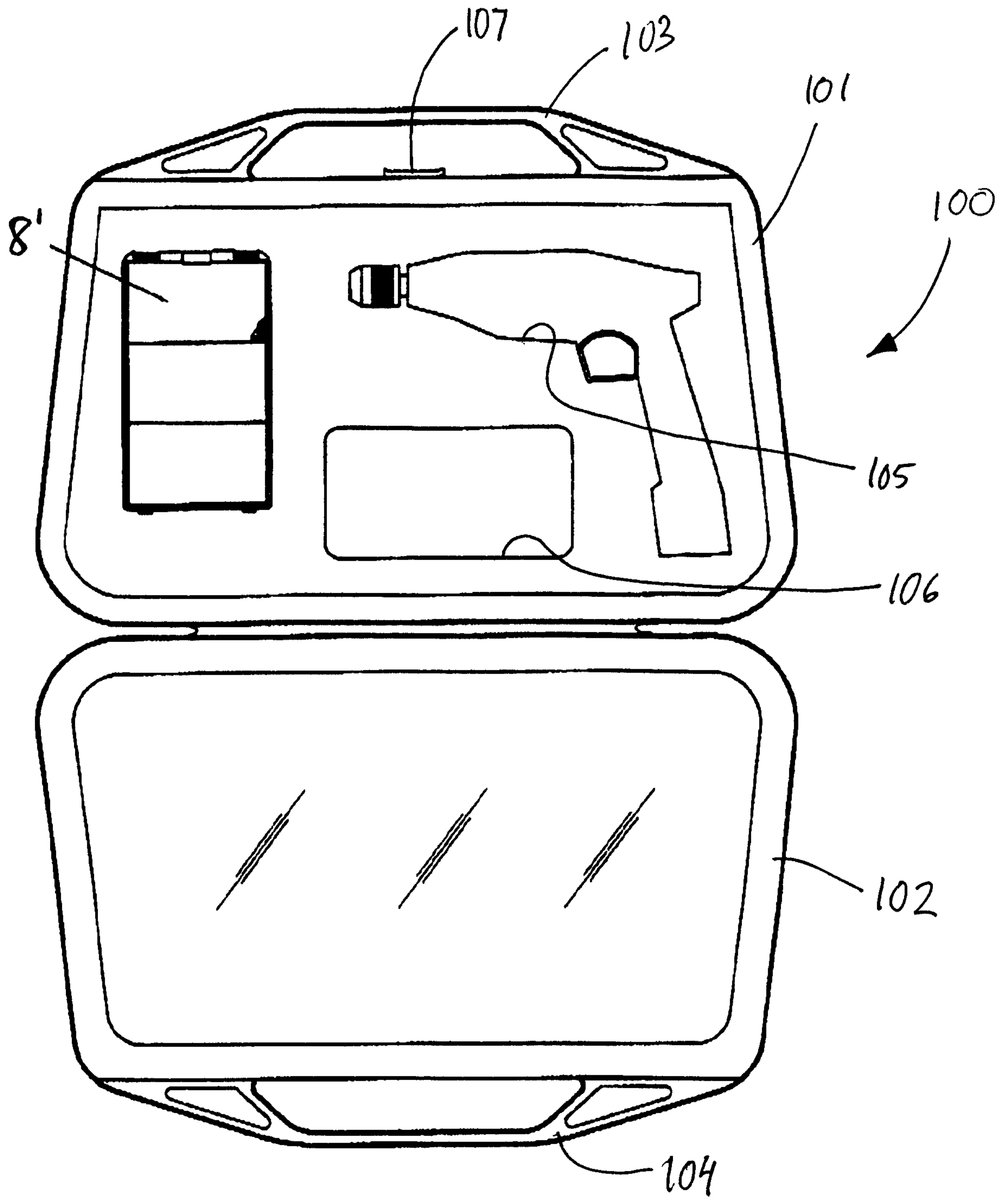

Fig. 20

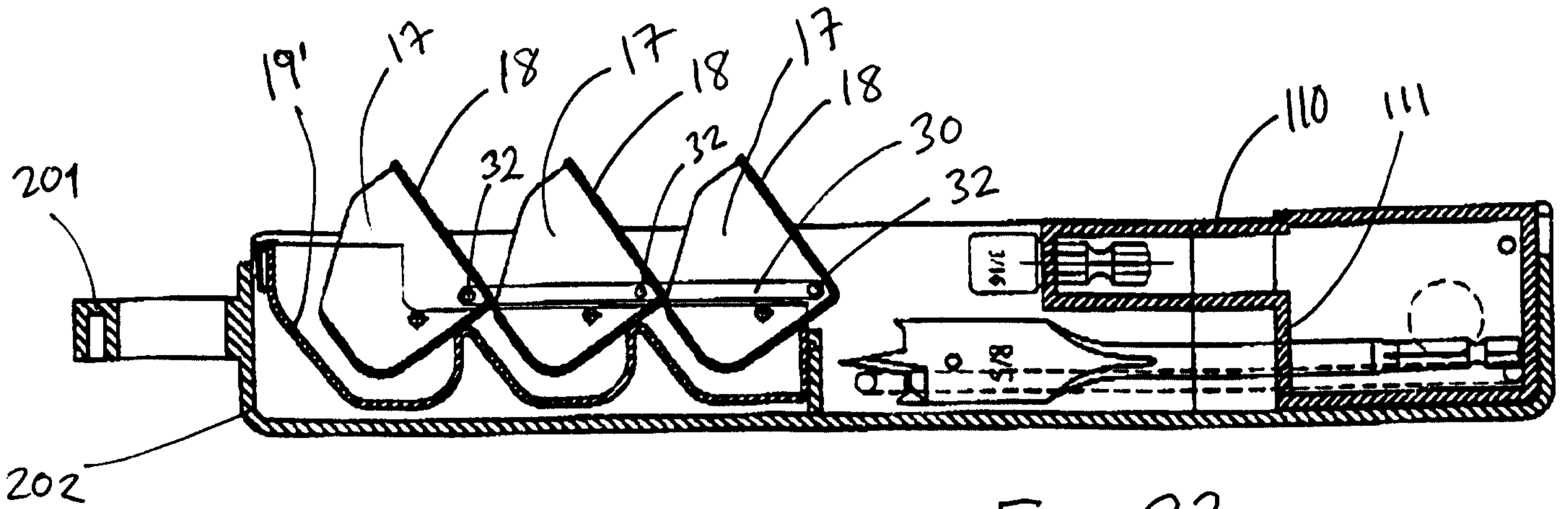

Fig. 23

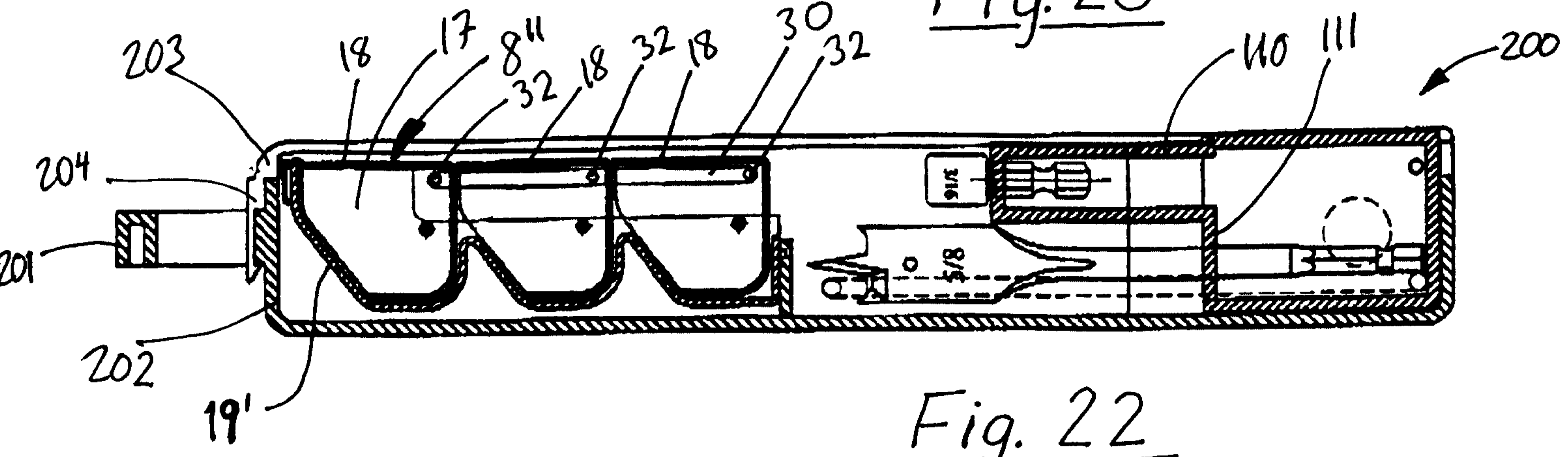

Fig. 22

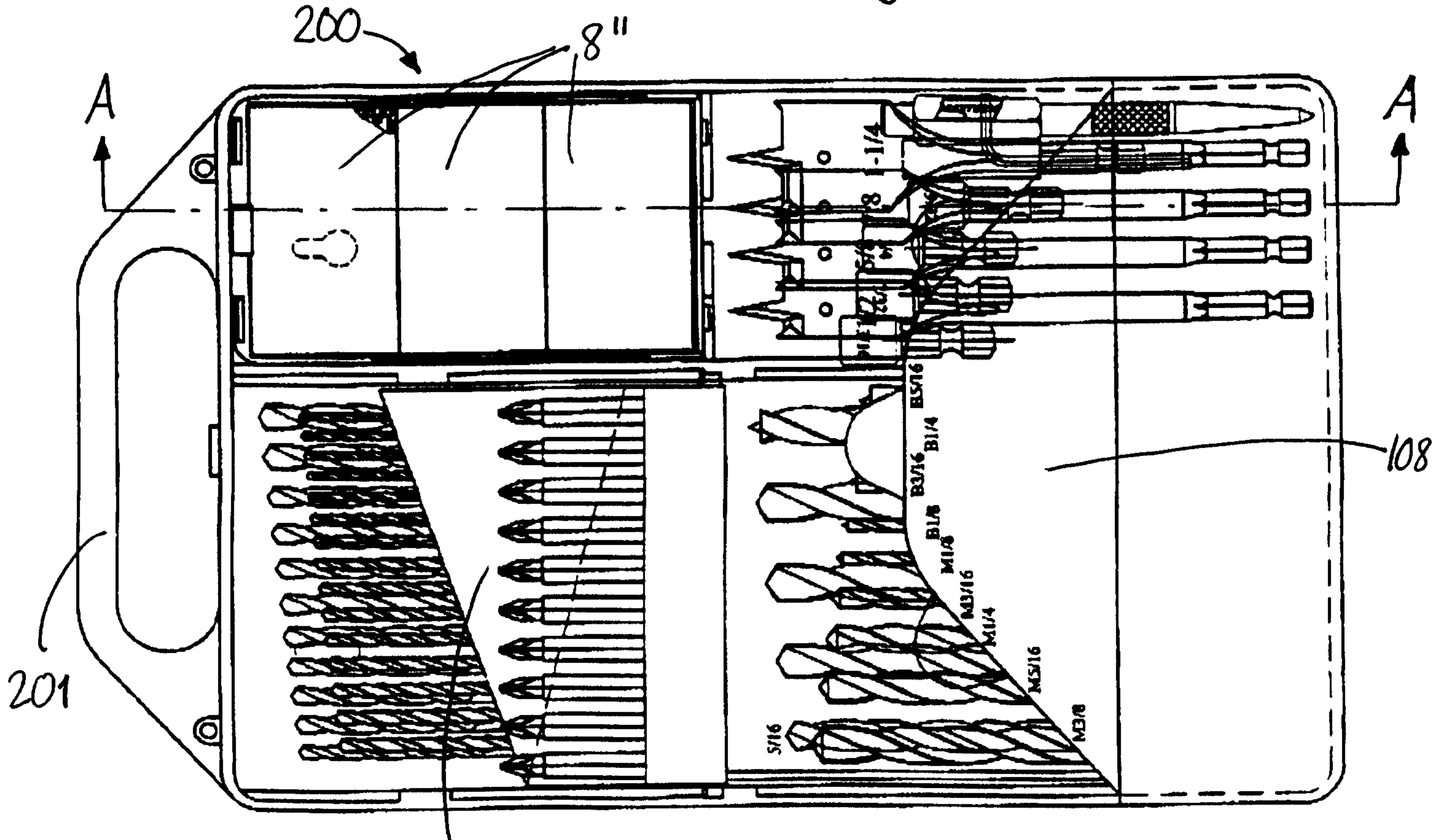

Fig. 21

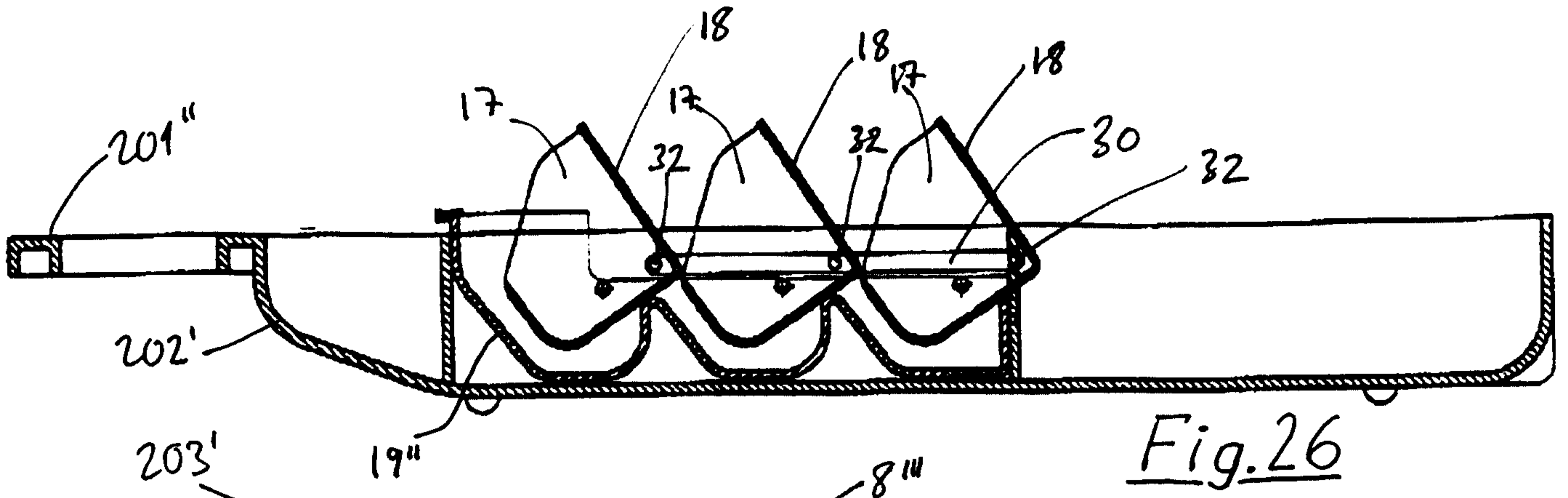

Fig. 26

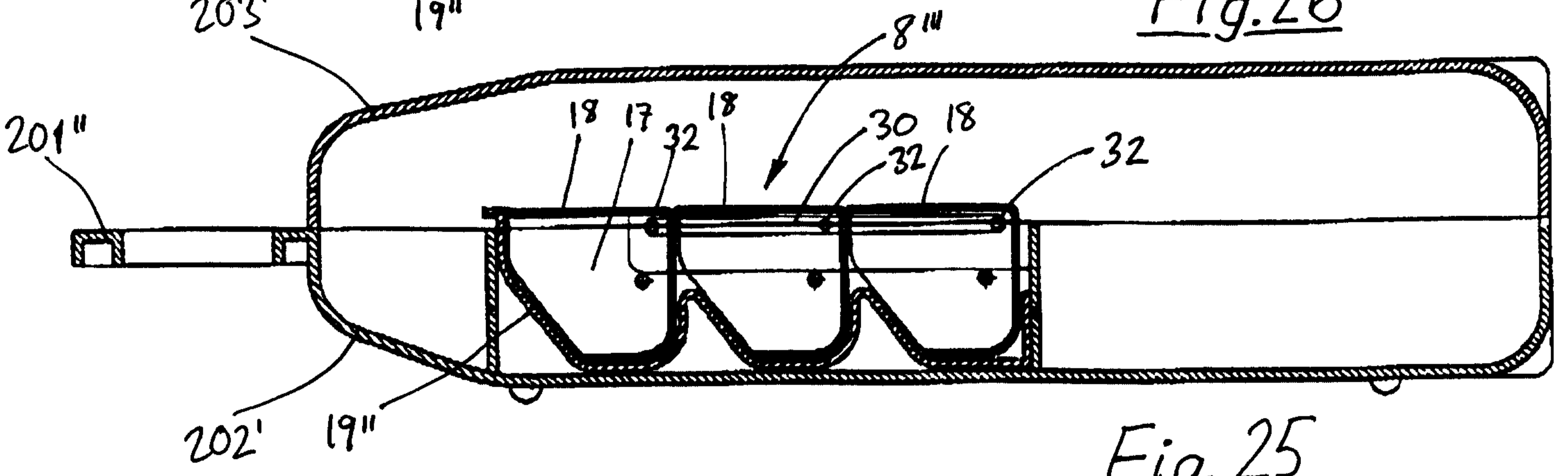

Fig. 25

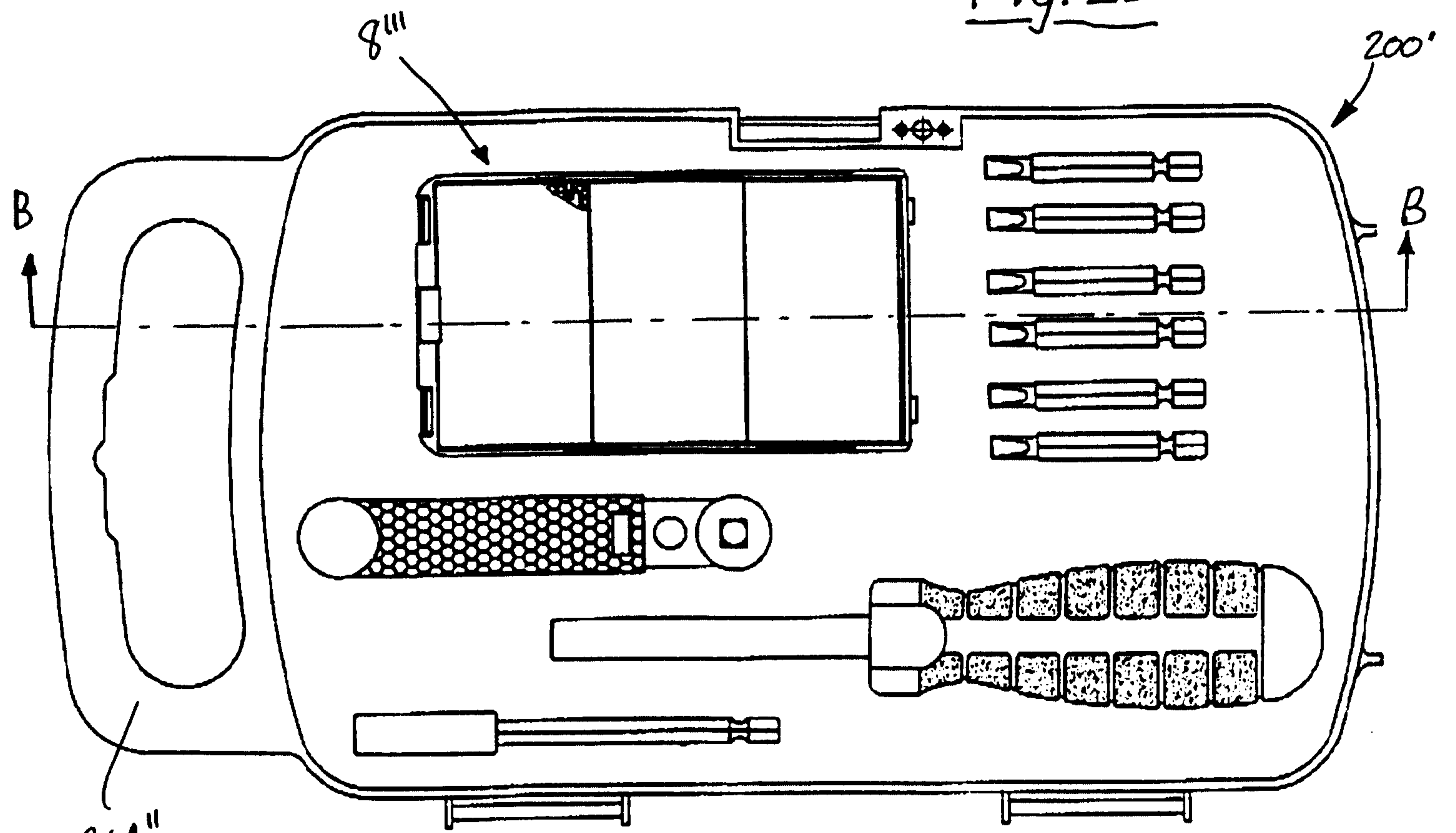

Fig. 24

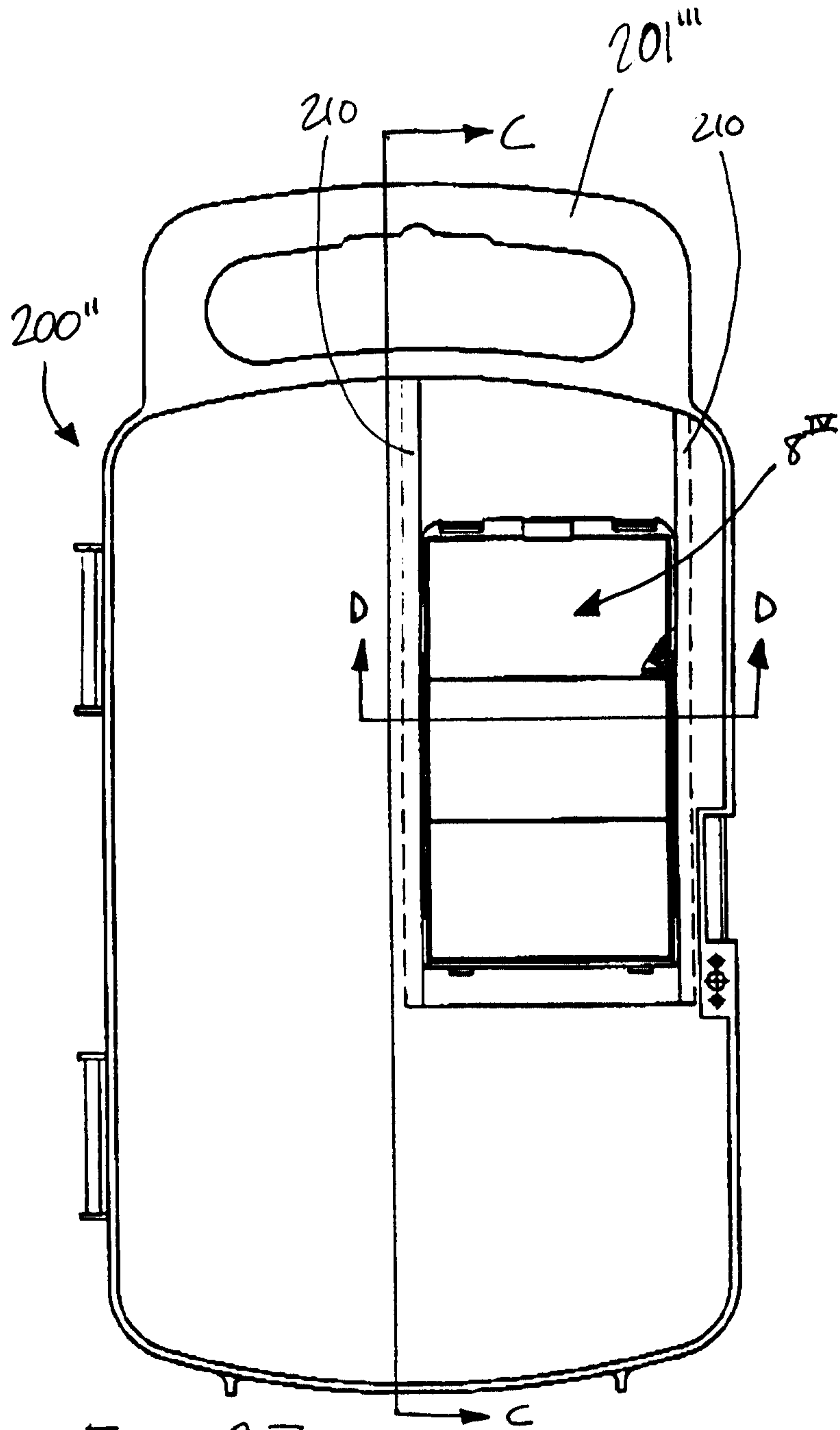

Fig. 27

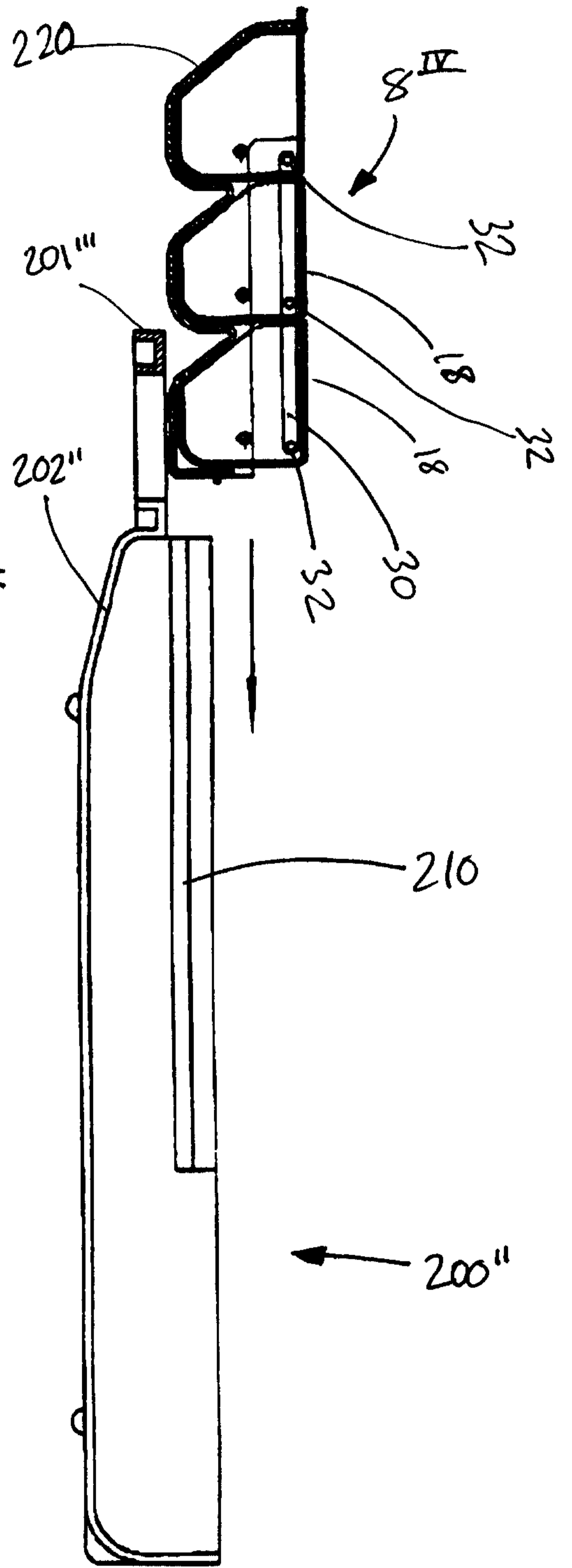

Fig. 28

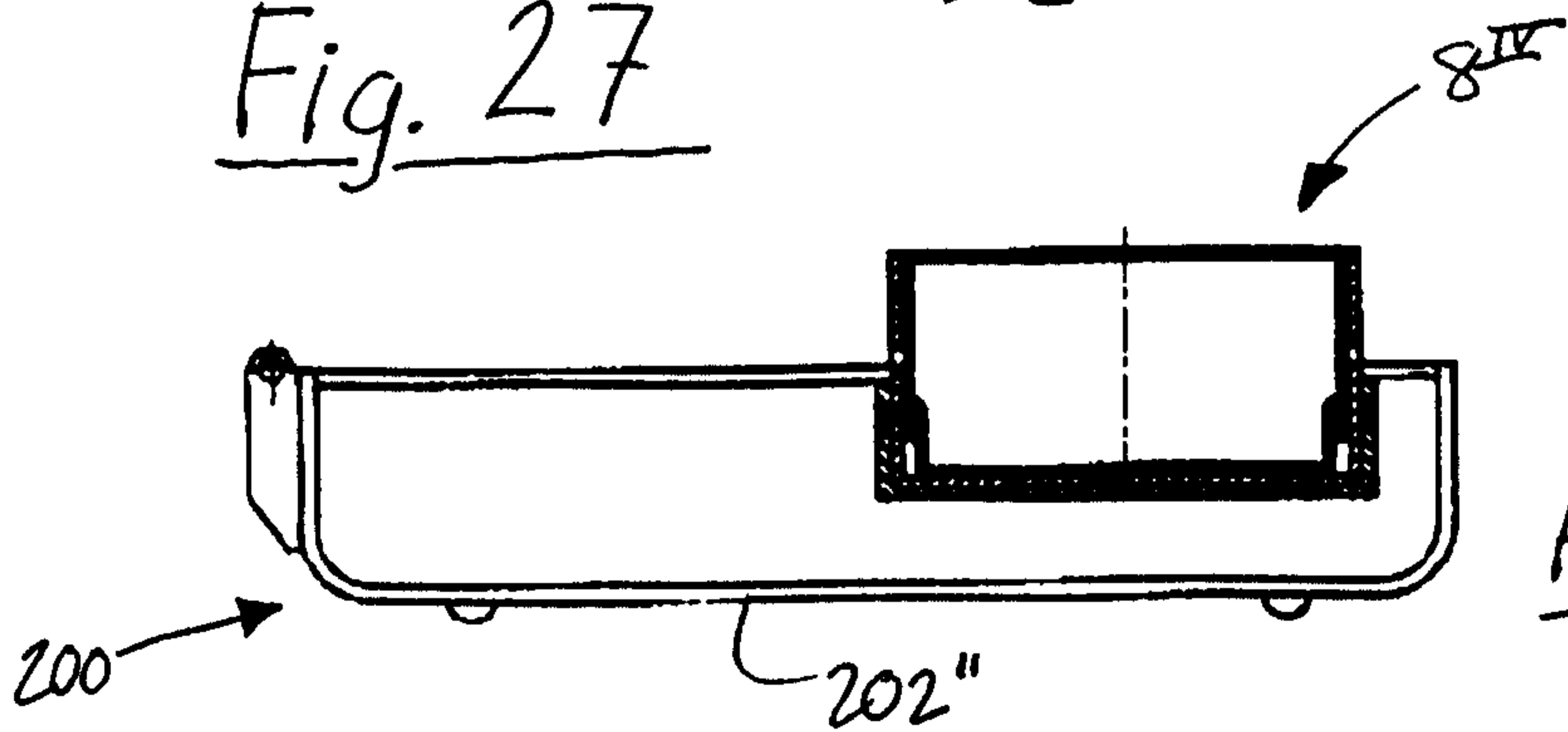

Fig. 29

