

**(12) PATENT**  
**(19) AUSTRALIAN PATENT OFFICE**

**(11) Application No. AU 200030192 B2**  
**(10) Patent No. 761799**

(54) Title  
**Bale wrapping implement**

(51)<sup>7</sup> International Patent Classification(s)  
**A01D 089/00 A01F 015/07**

(21) Application No: **200030192**

(22) Application Date: **2000.04.28**

(30) Priority Data

(31) Number	(32) Date	(33) Country
<b>19919323</b>	<b>1999.04.28</b>	<b>DE</b>

(43) Publication Date : **2000.11.02**

(43) Publication Journal Date : **2000.11.02**

(44) Accepted Journal Date : **2003.06.12**

(71) Applicant(s)  
**Deere and Company**

(72) Inventor(s)  
**Jean Viaud**

(74) Agent/Attorney  
**DAVIES COLLISON CAVE,GPO Box 3876,SYDNEY NSW 2001**

(56) Related Art  
**WO 00/27179**  
**DE 4120733**  
**WO 96/12399**

## BALE WRAPPING IMPLEMENT

### Abstract of the Disclosure

5 A bale wrapping implement includes a main frame supported on a caster wheel mounted at the center of gravity of the device. The main frame is coupled to the axle of a large round baler for vertical pivotal movement so that the wrapping implement is able to follow the contour of the ground. An auxiliary support wheel is mounted to the main frame so that it engages the ground only when the bale wrapping device is supporting a bale to be wrapped. The main frame includes first and second components which are pivotally coupled to each other and a linkage including an extensible and retractable hydraulic actuator is coupled so  
10 that a pair of parallel rolls carried by the second component are disposed in a location close to the discharge gate of the baler for receiving a bale when the actuator is extended and are located remote from the gate in a position for wrapping the bale, when the actuator is retracted.



Our Ref:7480460

P/00/011  
Regulation 3:2

AUSTRALIA

---

Patents Act 1990

---

**ORIGINAL  
COMPLETE SPECIFICATION  
STANDARD PATENT**

Applicant(s): Deere & Company  
One John Deere Place  
Moline Illinois 61265-8098  
United States of America

Address for Service: DAVIES COLLISON CAVE  
Patent & Trade Mark Attorneys  
Level 10, 10 Barrack Street  
SYDNEY NSW 2000

Invention Title: Bale Wrapping Implement

The following statement is a full description of this invention, including the best method of performing it known to me:-

## BALE WRAPPING IMPLEMENT

The present invention relates to bale wrapping implements, and more specifically, relates to such implements as are trailed from a large round baler and used to wrap bales ejected onto the device from such baler.

5

### Background of the Invention

Bale wrapping implements are employed for the packaging of bales, preferably bales formed by balers from harvested crop, for example, grass. The packaging results in the relatively small amount of baled silage being enclosed completely in an air-tight material, for example, in foil or sheeting.

10

DE-A 1-41 20 733 shows a bale wrapping implement for the packaging of a bale with foil, the machine including a main frame supported on two wheels arranged close to the baler and an arrangement for wrapping the bale. The main frame is rigidly connected to the baler and includes an adjustable telescoping bale transport frame for the transport of a bale, received from the bale-forming chamber of the baler once the bale discharge gate is

15

opened, to the bale wrapping arrangement.  
U.S. Patent No. 4,685,270, granted to Brambilla on 11 August 1987 shows a bale wrapping implement having a relatively large main frame coupled in trailing relationship to a large round baler for pivoting vertically at its attachment with the baler and supported on a pair of caster wheels.

20

The problems underlying the invention is seen in the costly configuration of known bale wrapping implements.

25

According to one aspect of the present invention there is provided a bale wrapping implement adapted for being coupled in trailing relationship to a baler, said implement including a main frame having a first frame component having a forward end defined by a coupling adapted for connection to the baler, said main frame further including a second frame component including a bale-receiving arrangement adapted for supporting a bale when discharged from the baler, at least one support wheel connected to said main frame, and a connecting assembly connecting said second frame component to said first frame component for being selectively moved in such a way that a spacing between the second frame component and the baler can be varied, the improvement comprising: said connecting assembly establishing a connection allowing said second frame component may be swung substantially horizontally relative to said first frame component.

30

Preferred embodiments of the invention will be hereinbefore described with reference to the accompanying drawings, and in those drawings:

35

### Brief Description of the Drawings

FIG. 1 is a somewhat schematic right rear perspective view showing a bale wrapping implement coupled to a baler with its main frame oriented in a first position assumed for wrapping or packaging a bale.

FIG. 2 is a view of the bale wrapping implement, shown in FIG. 1, but with the main frame oriented in a second position assumed for receiving a bale discharged from the baler.

Description of the Preferred Embodiment

5           FIGS. 1 and 2 show a baler 10, that can be coupled to a towing vehicle, not shown, such as, for example, an agricultural utility vehicle or an agricultural tractor, with an attached bale wrapping implement 12 for the packaging or wrapping of a bale, not shown, in a preferably air-tight material, such as, for example, a sheet or foil. The baler 10 is preferably configured as a large round baler, however, the employment of a baler for the  
10       production of other shapes of bales, for example, parallelepiped bales, is also conceivable. The baler 10, shown only partially, is provided with a housing 14 that forms opposite sides of a bale-forming chamber formed in part by a plurality of bale-forming belts 15 supported in side-by-side relationship by a plurality of belt support rolls and other structure (not shown) for effecting the formation of round bales within the baling chamber.  
15       Approximately the rear half of the baling chamber is defined by a discharge gate 16, shown here in a lowered closed position, that can be raised about a transverse pivot (not shown), at the upper forward corner of the gate 16, to an open position after the completion of a bale in order to discharge the bale from the bale-forming chamber of the baler 10. The housing 14 is supported on a pair of ground wheels 18 that are rotatably mounted to  
20       opposite ends of an axle 20 carried by the housing 14.

The bale wrapping implement 12 includes a main frame 22 supporting a bale

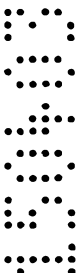
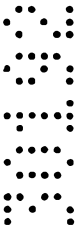

wrapping or packaging arrangement 23 including an angular wrapping arm support frame 24 having an upper terminal end supporting a motor 25 having a downwardly projecting output shaft to which a wrapping arm 26 is coupled. Such a wrapping arrangement 23 is described in detail, for example, in DE-A1-41 20 733, published 7 January 1993, the contents of which  
5 are incorporated herein by reference.

The frame 22 comprises a first elongate, beam-like frame component 27 having its forward end journalled for pivoting about the axle 20, and a second elongate, beam-like frame component 28 having an angled end received between, and pivotally coupled, as by a vertical pin 29, to a pair of horizontal, vertically spaced plates 30. A horizontal section 31 of  
10 the wrapping arm support frame 24 is received between rear portions of the plates 30 and is pivotally coupled to them by a vertical pin 32. A pair of substantially horizontal, parallel rolls 33 are cantilever-mounted from a straight section of the second frame component 28 so as to be spaced from each other for receiving a bale delivered from the baler 10. With reference to FIG. 1, the right-hand roll 33 is mounted for being slid along the second frame component 28 relative to the left-hand roll 33 so that a bale resting on the rolls 33 will drop  
15 between them onto the ground after the bale has been wrapped. The rolls 33 can be brought into rotation by drive including a motor, not shown, so that a bale lying upon the rolls 33 will, in turn, be brought into rotation to aid in it being wrapped completely with material dispensed from a supply roll of wrapping material carried at the end of the wrapping arm 26 as the arm 26 is revolved by the motor 25. In place of individual rolls 33, pairs of rolls or rolls in other groupings or a usual wrapping table, on which the bale could be brought into rotation, for example, by a belt drive, could be applied.

An actuator 34 in the form of a double-acting hydraulic motor with a cylinder 36 and a piston rod 38 is provided on the main frame 22. The actuator 34 can be supplied with  
20 hydraulic pressure from a pressure source, not shown. The actuator 34 has its cylinder end coupled to a horizontal projection 40 that is joined to the first frame component 27 and extends to the outside of the bale wrapping device 12 and has its rod end coupled to a horizontal projection 42 defined at the end the lower horizontal section 31 of the wrapping arm support frame 24. The lower horizontal section 31 of the wrapping arm support frame  
30 24 is connected through a link 44 with the second frame component 28, the link 44 having its opposite ends respectively pivotally attached, as at vertical pins 46 and 48, to the lower section 31 of the wrapping arm support frame 24, and to the second frame component 28.

The first frame component 27 is supported on the ground by a support wheel 50, configured as a swiveling or pendulous caster, that is, it is supported in bearings in such a

way that it can pivot freely about an at least approximately vertical axis, in order to follow the direction of operation pre-set by the towing vehicle or by the baler 10. The caster wheel 50 is here shown as having its swivel axis defined by the pivot pin 32 that defines the pivotal connection between the first frame component 27 and the wrapping arm support frame section 31. The support wheel 50 is arranged at the first frame component 27 in the region of the center of gravity of the bale wrapping device 12 in the unloaded condition, that is, when there is no bale received on the rolls 33. On a free end 52 of the second frame component 28 of the main frame 22, a further smaller auxiliary support wheel 54 is provided that usually does not touch the ground when the bale wrapping device is unloaded and that, in the present embodiment, is configured as a freely swiveling caster wheel. With the support wheel 50 located in the region of the center of gravity of the bale wrapping device 12, torsional loads on the frame 22 are averted.

In operation, when the bale wrapping implement 12 is in a condition not loaded by a round bale and is towed by the baler 10, which is coupled to the towing vehicle, the bale wrapping device 12 is supported on the ground only by the support wheel 50, with the latter conforming automatically to the direction of operation established by the towing vehicle or the baler 10.

The bearing support of the first frame component 27 on the axle 20 of the baler 10 permits vertical pivotal movement of the wrapping implement 12 in order to permit the implement to follow the contour of the ground, with the support wheel 40 always remaining in contact with the ground. The bearing support of the frame component 27 does not permit it to move in the horizontal direction, thereby a reverse operation of the train of baler 10 and bale wrapping implement 12 is possible without leading to a deflection or jackknifing of the bale wrapping implement 12. While the single degree of freedom of motion established by the journaled connection of the main frame component 27 to the axle is preferred, other couplings are possible which would permit horizontal movement, but steps could be taken to lock out such possible horizontal movement.

During the wrapping operation, that is, when the bale wrapping implement 12 is loaded by a bale delivered by the baler 10 after completion of the baling process, the bale wrapping implement 12 may also become supported on the ground by the auxiliary support wheel 54. Due to the additional weight of the bale, the auxiliary support wheel 54 can also briefly come into contact with the ground, for example, on soft ground, since the frame 22 can deflect torsionally in the region of its inherent flexibility. The frame 22 can then be supported on the ground by the auxiliary wheel 54, in order to prevent excessive twisting of

the frame 22 and any ensuing damage.

The operation of the wrapping implement 12 is hereinbelow briefly stated. The frame 22 of the bale wrapping implement 12 can be repositioned by the actuator 34 between a receiving position shown in FIG. 2 and a wrapping position shown in FIG. 1. For this purpose, the actuator 34 is supplied with pressure by the hydraulic pressure source, not shown, whereupon the piston rod 38 is extended or retracted in the cylinder 36. If the piston rod 38 is retracted, the frame 22 is in the wrapping position shown in FIG. 1, in which the first frame component 27 and the second frame component 28 cooperate to define an L-shape. In this position, the second frame component 28 is located at such a spacing to the discharge gate 16 of the baler 10 that a bale lying on the rolls 33 can be brought into rotation by the rolls 33, which are driven in a manner not shown, and can be wrapped with material by the arrangement 23, without any interference by the discharge gate 16. The discharge gate 16 can again be closed, in order to enable the formation of a new bale in the baler 10.

In order to simplify the delivery of a bale to the bale wrapping device after the completion of the baling process and opening of the discharge gate 16, the second frame component 28, together with the rolls 33, are brought closer to the discharge gate 16. For this purpose, the piston rod 38 of the actuator 34 is extended, whereby the wrapping arm support frame 24, and with it also the second frame component 28, are respectively pivoted about the pivot pins 29 and 32, with the second frame component 28 preferably moving through approximately 90°, so that it becomes positioned alongside the first frame component 27, and the rolls 33 are arranged, corresponding to the illustration in FIG. 2, in such a way that the bale delivered by the baler 10 can be received by the rolls 33. Following this, the piston rod 38 of the actuator 34 is retracted so that the wrapping process can be performed in the L-shaped arrangement of the frame 22 shown in FIG. 1 and wherein the discharge gate 16 can be closed.

A repositioning of the actuator 34 can be initiated simply, for example, by the operator of the towing vehicle, not shown, in which the operator, for example, actuates a switch for activating an electromagnetic valve, so that either a region on one side, or a region on another side, of a piston coupled to the piston rod 38 is supplied with pressure fluid. But it is also conceivable that the extension and retraction of the piston rod 38 of the actuator 34, and thereby a change in the position of the second frame component 28 relative to the first frame component 27, can be controlled as a function of the operating condition of the baler 10. For example, the repositioning into the position shown in FIG. 2 can be performed by an extension of the piston rod 38 of the actuator 34 when a sensor provided on

the baler 10 reports that the baling or binding process is completed, For this purpose, the output value of the sensor can be received by a control unit, which controls an electromagnetic valve, again corresponding to the manual actuation described above, through which the actuator 34 is supplied with pressure.

5           After the completion of the wrapping process, the right-hand roll 33, as viewed in FIG. 1, can be slid or otherwise brought into its position spaced at its greatest distance from the left-hand roll 33, so that the wrapped bale resting on the rolls 33 is deposited on the ground. The bale remains lying on the ground in this position, while the towing vehicle with the baler 10 and the attached bale wrapping implement 12 moves on, A repositioning  
10 of the roll 33 can be performed, for example, by a hydraulic motor or another drive. This can also be attained simply by means of a lock that is released after the completion of the wrapping process, whereby the roll 33 slides on the basis of the weight of the bale against the force of a spring. After the bale is deposited, the spring returns the roll 33 into its initial position, in which the lock is again closed. The opening and closing of the lock can also be  
15 performed by the control arrangement, for example, by an electromagnetic switch. It is also possible that the individual operations are performed or controlled by an operator, for example, by the driver of a towing vehicle.

Throughout this specification and the claims which follow, unless the context requires otherwise, the word "comprise", or variations such as "comprises" or  
20 "comprising", will be understood to imply the inclusion of a stated integer or step or group of integers or steps but not the exclusion of any other integer or step or group of integers or steps.

The reference to any prior art in this specification is not, and should not be taken as, an acknowledgment or any form of suggestion that the prior art forms part of the  
25 common general knowledge in Australia.

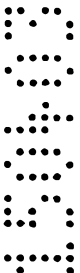
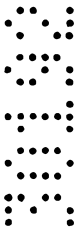

THE CLAIMS DEFINING THE INVENTION ARE AS FOLLOWS:

1. A bale wrapping implement adapted for being coupled in trailing relationship to a baler, said implement including a main frame having a first frame component having a forward end defined by a coupling adapted for connection to the baler, said main frame  
5 further including a second frame component including a bale-receiving arrangement adapted for supporting a bale when discharged from the baler, at least one support wheel connected to said main frame, and a connecting assembly connecting said second frame component to said first frame component for being selectively moved in such a way that a spacing between the second frame component and the baler can be varied, the  
10 improvement comprising: said connecting assembly establishing a connection allowing said second frame component may be swung substantially horizontally relative to said first frame component.
2. The bale wrapping implement, as defined in claim 1, wherein said connecting assembly establishes a single upright pivot joint between said first and second frame  
15 components and about which said second frame component is pivotable.
3. The bale wrapping implement, as defined in claim 1, and further including an actuating linkage including at least one actuating device coupled for selectively swinging said second frame component relative to said first frame component as permitted by said connection established by said connecting assembly.
- 20 4. The bale wrapping implement, as defined in claim 3, wherein said actuating linkage includes a wrapping arm support frame pivotally coupled to said first frame component; and said actuating device being coupled between said first frame component and said wrapping arm support frame.
5. The bale wrapping implement, as defined in claim 4, wherein said actuating linkage  
25 includes a link having opposite ends respectively coupled to said wrapping arm support frame and said second frame component.
6. The bale wrapping implement, as defined in claim 1, wherein said first frame component extends fore-and-aft; said second frame component having an end pivotally attached to a rear location of said first frame component for pivotal movement about a first  
30 upright axis; an actuating linkage including an extensible and retractable actuator coupled between said first and second frame components; said bale receiving arrangement being coupled to said second frame component; said bale receiving arrangement being in a wrapping position displaced rearward of said first frame component when said actuator is retracted, and being in a bale-receiving position located alongside said first frame  
35 component, when said actuator is extended.

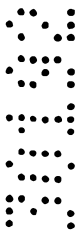

7. The bale wrapping implement, as defined in claim 1, wherein said bale-receiving arrangement includes at least two elongate, parallel rolls.

8. The bale wrapping implement, as defined in claim 7, wherein one of said rolls is mounted for selective movement perpendicular to another one of said rolls, whereby a bale supported on said one and another of said rolls may fall to the ground between them.

9. The baling wrapping implement, as defined in claim 7, and further including an actuator linkage connected between said first and second frame components and including an extensible and retractable actuator; said first frame component being essentially defined by a fore-and-aft extending first beam member; and said second frame component being defined essentially by a second beam member having a straight section; and said straight section of said second frame component extending transversely so as to define an L-shape with said first frame component when said actuator is retracted, and said straight section of said second portion of said main frame being positioned alongside said first portion of said frame when said actuator is extended.

10. The bale wrapping implement, as defined in claim 9, wherein a rear section of said first frame component is defined by upper and lower horizontal plates; said second frame component having an end located between and coupled to a forward location of said plates for pivoting about said first upright axis; a wrapping arrangement including a generally horizontal wrapping arm support frame section located between and pivotally coupled to a rearward location of said plates for pivoting about a second upright axis; said operating linkage including a link having opposite ends respectively pivotally coupled to said wrapping arm support frame section and said second frame component; and said extensible and retractable actuator having opposite ends respectively coupled to said first frame component and to said wrapping arm support section.

11. The bale wrapping implement, as defined in claim 10, wherein one of said rolls is mounted for movement along said straight section of said second component of said frame, whereby said one of said rolls may be moved relative to the other of said rolls for permitting a bale supported on the rolls to fall onto the ground.

12. Bale wrapping implement, substantially as hereinbefore described with reference to the drawings.

DATED this 28th day of April 2000

**DEERE & COMPANY**

By their Patent Attorneys  
**DAVIES COLLISON CAVE**



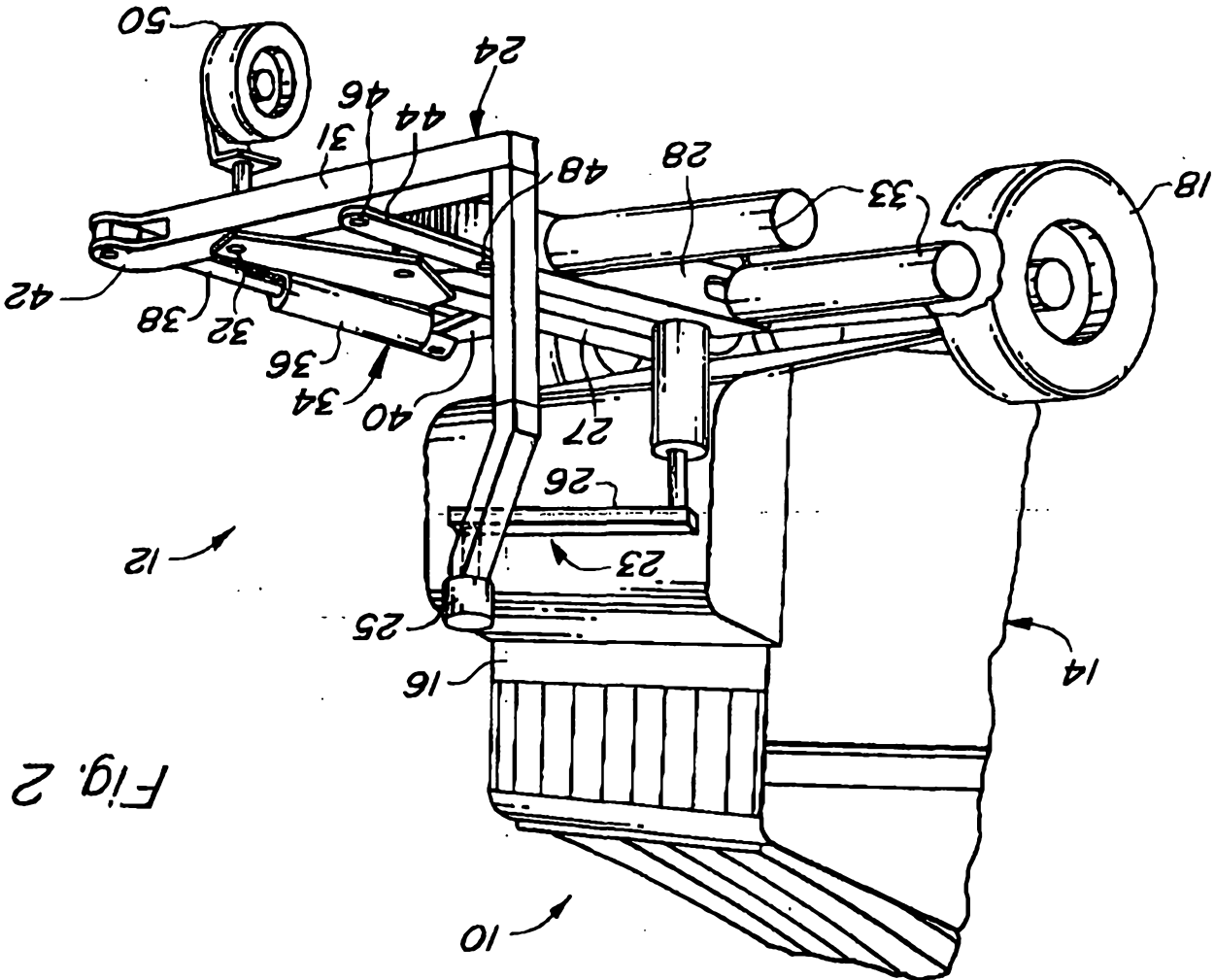

Fig. 2

2/2

