

(19) World Intellectual Property
Organization
International Bureau



(43) International Publication Date
12 February 2004 (12.02.2004)

PCT

(10) International Publication Number
WO 2004/013012 A1

- (51) International Patent Classification⁷: **B65D 43/02**
- (21) International Application Number:
PCT/CA2003/000949
- (22) International Filing Date: 20 June 2003 (20.06.2003)
- (25) Filing Language: English
- (26) Publication Language: English
- (30) Priority Data:
60/399,731 1 August 2002 (01.08.2002) US
PCT/CA02/01311 26 August 2002 (26.08.2002) CA
PCT/CA03/00055 17 January 2003 (17.01.2003) CA
- (71) Applicant (for all designated States except US): **STACK TECK SYSTEMS LTD.** [CA/CA]; 1 Paget Road, Brampton, Ontario L6L 1H7 (CA).
- (72) Inventor; and
- (75) Inventor/Applicant (for US only): **DE CANDIDO, Rick** [CA/CA]; 27 Ready Court, Brampton, Ontario L6Y 4T4 (CA).
- (74) Agents: **MILNE, Peter** et al.; Gowling Lafleur Henderson LLP, Suite 4900, Commerce Court West, Toronto, Ontario M5L 1J3 (CA).
- (81) Designated States (national): AE, AG, AL, AM, AT, AU, AZ, BA, BB, BG, BR, BY, BZ, CA, CH, CN, CO, CR, CU, CZ, DE, DK, DM, DZ, EC, EE, ES, FI, GB, GD, GE, GH, GM, HR, HU, ID, IL, IN, IS, JP, KE, KG, KP, KR, KZ, LC, LK, LR, LS, LT, LU, LV, MA, MD, MG, MK, MN, MW, MX, MZ, NO, NZ, OM, PH, PL, PT, RO, RU, SC, SD, SE, SG, SK, SL, TJ, TM, TN, TR, TT, TZ, UA, UG, US, UZ, VC, VN, YU, ZA, ZM, ZW.
- (84) Designated States (regional): ARIPO patent (GH, GM, KE, LS, MW, MZ, SD, SL, SZ, TZ, UG, ZM, ZW), Eurasian patent (AM, AZ, BY, KG, KZ, MD, RU, TJ, TM), European patent (AT, BE, BG, CH, CY, CZ, DE, DK, EE, ES, FI, FR, GB, GR, HU, IE, IT, LU, MC, NL, PT, RO, SE, SI, SK, TR), OAPI patent (BF, BJ, CF, CG, CI, CM, GA, GN, GQ, GW, ML, MR, NE, SN, TD, TG).
- Published:
— with international search report
— with amended claims
- For two-letter codes and other abbreviations, refer to the "Guidance Notes on Codes and Abbreviations" appearing at the beginning of each regular issue of the PCT Gazette.

(54) Title: HOOK STYLE TAMPER EVIDENT LID

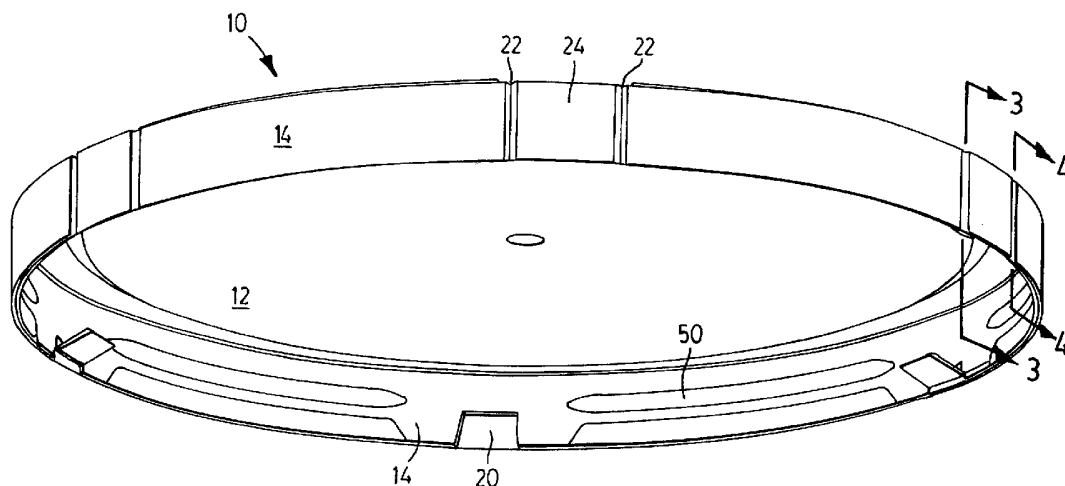

(57) Abstract: A tamper evident lid (10) is provided for mounting over an opening of a container having sidewalls (30) with a lip (32) extending outwardly therefrom to define the opening (34). The lid (10) has a base, a rim (14) extending about a perimeter of the base (12) for receiving the lip (32) and at least one finger (20) extending upwardly from the rim (14) and toward the base (12) for engaging an underside of the lip (32). A frangible membrane (22) is associated with the fingers (20) to facilitate outward tearing of the finger regions away from the sidewalls (30). Each finger (20) has a length exceeding the distance between an inside of the lip (32) and the sidewall (30).

WO 2004/013012 A1

TITLE: HOOK STYLE TAMPER EVIDENT LID

This application is a continuation-in-part of International Application No. PCT/CA03/00055, filed January 17, 2003, and also a continuation-in-part of
5 International Application No. PCT/CA02/01311, filed on August 26, 2002, and also claims the benefit of U.S. Provisional Application No. 60/399,731, filed August 1, 2002.

FIELD OF THE INVENTION

This invention relates generally to injection moulded containers and
10 their lids. More specifically this invention relates to tamper evident lids which may be applied to standard containers.

BACKGROUND OF THE INVENTION

Tamper evident (TE) features are very important in the packaging industry. Unfortunately, packages having tamper evident features generally
15 require specific container and lid designs making the container and the lid a unique combination. A disadvantage to this type of design is that expensive moulds are required not only for the container but for the lid and the moulds are often limited in design to a single product.

Many applications in the food packaging industry currently use
20 "standard" container sizes, which can be purchased from a multitude of suppliers. The containers are generally filled with packaging machinery adapted to those container sizes. If special containers and lids are to be used, it may be necessary to install additional machinery in a filling line to accommodate assembly limitations caused by the special tamper evident
25 containers.

U.S. Patent No. 5,540,342 by Rathbun describes a lid having a dual locking system to retain the lid on a container. The lid uses a plurality of primary beads and secondary locking ribs to retain the lid on the container. However, one disadvantage of Rathbun's lid is that the locking ribs are

completely removed from the lid once the lid is initially from the container, thus removing all visual evidence of the released locking ribs.

It is an object of the present invention to provide a tamper evident lid which may be used with a standard container. Preferably the lid may be
5 mounted onto such a container using conventional packaging equipment currently available in most automated filling lines.

SUMMARY OF THE INVENTION

A tamper evident lid is provided for mounting over an opening of a container having sidewalls with a lip extending outwardly therefrom to define
10 an opening. The lid has a base, a rim extending about the base for receiving the lip and at least one resiliently flexible finger extending radially inwardly from the rim for engaging the lip. Each finger has a length exceeding the distance between an inside of the lip and the sidewall and extends towards the base when the lid is mounted on the container. At least one frangible
15 membrane is formed in the rim and associated with at least one of the fingers for facilitating tearing of the rim to disengage the associated finger(s) from the lip thereby enabling removal of the lid from the container while leaving evidence of removal by way of a torn frangible membrane.

The rim may have an upper end adjacent the base and a lower edge
20 distal the base with the frangible membrane extending from the lower edge toward the upper end.

A respective of the frangible membranes may be disposed on opposite sides of at least one finger. Alternatively, at least one pair of fingers may be provided with each one of the pair of fingers disposed on an opposite side of
25 the frangible membrane.

The frangible membrane may extend to a membrane hinge formed in at least one of the rim and the base. The membrane hinge may be positioned to facilitate disengagement of the associated finger from the lip upon tearing of the frangible membrane.

The associated finger may be disposed between the membrane hinge and the lower edge.

The frangible membrane may extend to at least one membrane hinge formed in the rim. Each such membrane hinge may extend from the lower edge toward the base with an associated finger disposed in any area bordered by the frangible membrane, a membrane hinge and a lower edge.

A pair of fingers may be disposed between a pair of membrane hinges extending from the lower edge toward the base. A frangible membrane may extend from the lower edge to each one of the pair of the membrane hinges so that each of the fingers is disposed in an area bordered by at least part of the frangible membrane, one of the membrane hinges and the lower edge.

A pair of radially spaced apart frangible membranes may be provided with at least one of the resilient fingers disposed therebetween. A membrane hinge may extend across the base between the frangible membranes to facilitate disengagement of the fingers from the lip upon tearing of the frangible membranes by bending a portion of the base away from the lip.

A plurality of fingers may be disposed between the frangible membranes of the embodiment described in the preceding paragraph.

At least one of the fingers may be a webbed finger having a web defined by a reduced thickness region extending toward the rim from a lip engaging end of the webbed finger which is distal the rim.

Each webbed finger may be provided with a passage therethrough in the form of a window to promote drainage of fluid trapped between the webbed finger and the rim.

The fingers may be of various profiles including rounded, parallel faced straight, tapered narrowing toward the rim and tapered narrowing toward the rim with a scallop facing the container at an outer end thereof distal the rim.

Each finger may be curved in a direction generally corresponding to a curvature of the container to provide a lengthened contact zone with the lip.

The rim may be a recess extending from the fingers to the lower edge to accommodate the fingers thereby facilitating stripping of the lid in an injection moulding process.

The fingers may extend from the lower edge of the rim.

At least one pull tab may extend from the lower edge of the rim to facilitate tearing of at least one of the frangible membranes.

A stacking ring may extend about the base away from the rim to engage the lower edge of an adjacent tamper evident lid when the lids are stacked in order to resist lateral shifting therebetween. The stacking ring may be segmented or continuous.

A chamfer may extend into the rim from the lower edge at the juncture of the frangible membranes and the lower edge to avoid a sharp corner at the juncture upon tearing of the frangible membrane.

DESCRIPTION OF DRAWINGS

Preferred embodiments of the present invention are described below with reference to the accompanying illustrations in which:

Figure 1 is a perspective view from below of a tamper evident lid according to the present invention;

Figure 2 is a perspective view from above of the lid of Figure 1;

Figure 3A is a perspective sectional view taken at line 3-3 of Figure 1;

Figure 3B is a view corresponding to Figure 3A but taken from the inside rather than from the outside of the lid;

Figure 4 is a perspective sectional view taken on line 4-4 of Figure 1;

Figure 5 is an axial section of an outer portion of a lid according to the present invention illustrating how it mounts over a container;

Figure 6 is an axial sectional view of a lid according to the present invention being moulded and illustrating the associated mould components;

5 Figure 7 is a schematic view of an injection moulding arrangement for forming a lid according to the present invention;

Figure 8 is a perspective view from below illustrating an alternate embodiment for a tamper evident lid according to the present invention;

10 Figures 8a and 8b are scrap perspective views illustrating alternate features associated with the Figure 8 embodiment;

Figure 9 is a sectional perspective view illustrating a further alternate embodiment for a tamper evident lid according to the present invention;

Figure 10a is a perspective view from above illustrating a still further embodiment for a tamper evident lid according to the present invention;

15 Figure 10b is a perspective from below of the Figure 10a embodiment;

Figures 11 and 11a illustrate alternate embodiments for a "finger" portion illustrating a tamper evident lid according to the present invention;

20 Figures 12 and 12a are respectively scrap perspective views from below and above illustrating a "pull tab" feature of a tamper evident lid according to the present invention;

Figures 13a, 13b, 13c and 13d are scrap perspective views illustrating further alternate embodiments for a "finger" portion of a tamper evident lid according to the present invention;

25 Figure 14 is a scrap perspective view illustrating a still further alternate embodiment for a "finger" portion of a tamper evident lid according to the present invention;

Figure 15 is a scrap perspective view illustrating an embodiment of a tamper evident lid according to the present invention wherein a "finger" portion extends from a lower edge thereof;

Figure 16 is a perspective view from above illustrating yet another
5 alternate embodiment for a tamper evident lid according to the present invention;

Figure 17 is a perspective view from above illustrating the use of chamfered edges as a safety feature associated with "tab" portions of a tamper evident lid according to the present invention;

10 Figure 18 is a perspective bottom view of a further embodiment of the lid of Figure 1;

Figure 19 is an enlarged view of an operated tab portion of the lid of Figure 18;

Figure 20 is a side sectional view taken on the line 5-5 of Figure 18;

15 Figure 21 is a perspective bottom view of an alternative embodiment of the lid of Figure 18;

Figure 22 is a side sectional view taken on line 6-6 of Figure 21; and Figure 23 is a top view of an alternative embodiment of the lid of Figure 18.

DESCRIPTION OF PREFERRED EMBODIMENTS

20 A tamper evident lid ("lid") according to the present invention is generally illustrated by reference 10 in the accompanying illustrations. The lid 10 has a base 12 and a rim 14 which extends about the perimeter of the base 12.

Discrete fingers 20 extend from an inside of the rim 14. The fingers
25 extend radially inwardly and toward the base 12 (inwardly and upwardly as illustrated in the figures).

The lid 10 is intended for mounting over a "standard container" 13 as illustrated in Figure 5. A portion of a sidewall of such a container 13 is shown in dashed lines at reference 30. As typical with such containers 13 which are commonly used for food and other applications, the sidewall 30 terminates in an outwardly and downwardly extending lip 32. The lip 32 defines an opening 34 over which the lid 10 may be mounted.

Each of the fingers 20 has a length which exceeds the distance or "gap" between the inside of the rim 14 and the outside of the sidewall 30 as illustrated at reference 41. The length of the fingers 20 exceeds the breadth of the gap as illustrated by arrow 44. Accordingly, when the lid 10 is forced over the lip 32, the fingers 20 flex toward a retracted position against the inside of the rim 14. Once fully past the lip 32, the fingers flex inwardly, away from the rim 14, to rest against the sidewall 30. The direction of this spring bias is indicated by reference 31. In order to enable the flexing of the fingers 20, the material of the lid 10 must have a desired degree of resiliency which is characteristic of the type of plastics typically used for such lids (polyethylene for example). Basically the fingers 20 must be able to flex without breaking off.

Once in place, removal of the lid 10 from the container 13 is resisted by the fingers 20 engaging an underside 36 of the lip 32. As the ends of fingers 20 rest against the sidewall 30, the fingers 20 can rely on the sidewall 30 for support and accordingly a tremendous amount of strength is not required from the fingers 20. This proves advantageous in stripping the lid 20 from an injection moulding assembly, as discussed below.

To either side of the fingers 20 is a frangible membrane 22 (see Fig. 1) formed in the rim 14 to define "tear tabs" 24. The tear tabs 24 may be pried away from the sidewall 30 by tearing the frangible membranes 22 to either side to move the fingers 20 out of engagement and away from the lip 32. This enables removal of the lid 10 from the container 13 but only by leaving evidence in the form of torn frangible membranes 22.

A membrane hinge 26 (see Fig. 3a) may be provided at the top of the tear tabs 24 to maintain the tear tabs 24 affixed to the remainder of the lid 10 after tearing of the frangible membranes 22. This avoids having to tear the tear tabs 24 out entirely in order for the fingers 20 to be disengaged from the lip 32. Without the hinge 26, the resiliency of the lid 10 might otherwise keep urging the fingers 20 into engagement with the lip 32 even with the frangible membranes 22 torn.

Alternatively the membrane hinge 26 may be substituted for a further frangible membrane 22 to allow complete removal of the tear tabs 24.

10 An inwardly extending rib 50 (see Fig. 1) may be provided about the rim 14 of the lid 10 between the break tabs 24. The ribs 50 serve to further secure the lid 10 over the opening 34 by engagement with the lip 32 (see Fig 5).

15 Preferably the rim 14 at the tear tabs 24 is thinner below the finger 20 (distal the base 12) than above the finger 20 (proximal the base 12) by an amount corresponding to the thickness of the fingers 20. This forms a recess 28 (see Fig 3b) which accommodates the fingers 20 during a stripping stage of the lid 10 in an injection moulding operation.

Figures 6 and 7 illustrate a mould assembly for plastic injection 20 moulding of the lid 10. The mould assembly includes a cavity 100 which receives a two-part mould core made up of a removing core poppet 102 and a core base 104. A stripper ring 110 extends about the core base 104 to engage a lower edge 18 of the rim 14 of the lid 10. The cavity 100 and moving core poppet 102 are movable in opposite relative directions as are the core 25 base 104 and moving core poppet 102.

After injection and solidification of a molten resin to form the lid 10, the formed lid 10 will typically shrink onto the moving core poppet 102 and core base 104 enabling the lid 10 in combination with the core poppet 102 and core base 104 and stripper ring 110 to be moved away from the cavity 100 as

the mould is opened. Next, the core poppet 102, stripper ring 110 and lid 10 move away from the core base 104 toward the cavity 100. The core poppet 102 stops moving and the stripper ring 110 pushes the lid 10 off of the poppet 102.

5 As shown by dashed lines in Figure 6, the finger 20 flexes away from the base 12 of the lid 10 and is accommodated by the recess 28 as the lid 10 is lifted off of the moving core poppet 102.

The fingers 20 will generally retain enough "memory" to resiliently flex toward their original position as the formed lid 10 cools after stripping.
10 Alternatively the fingers 20 may be configured to cool so as to point away from the base 12 ("down") and be pushed into an "upwards" position mechanically after moulding.

Although six tear tabs 24 are illustrated, other numbers are possible. Generally it is expected that six to eight will prove an optimal compromise
15 between security and effort to remove the lid 10. It may be possible to have as few as one tear tab 24 if it is broad enough to retain the lid 10 on the container 13. Two or more is preferable. It is generally not necessary to lift away all of the tear tabs 24 for removal of the lid 10. Lifting away the tear tabs 24 about
20 half the perimeter and sometimes less of the lid 10 will generally prove sufficient to enable removal of the lid 10 when installed on the container 13.

As illustrated in Figure 8 it isn't necessary to provide a frangible membrane 22 on opposite sides of the fingers 20. For example, more than one finger 20 may be provided between adjacent of the frangible membranes 22. Alternatively, as illustrated in Figure 8a, a single frangible membrane 22
25 may be provided adjacent the finger 20. Whether the latter arrangement is truly effective will depend on the overall configuration of the lid 10 and how many fingers 20 have to be displaced in order to release the lid 10. This arrangement may be less practical when several fingers 20 are used unless the frangible membrane 22 extends from a lower edge 29 (see Figure 11) of

the rim 14 about the finger 20 to a membrane hinge 26 on an opposite side of the finger 20 as illustrated in Figure 8b.

In some instances it may be desirable to avoid the use of a membrane hinge 26 or to provide one with significant restorative force characteristics. This might for example be the case where it is desired for the fingers 20 to participate in "locking" the lid 10 to the container lip 32 upon reapplication of the lid 10. Such an arrangement is illustrated in Figure 9.

As illustrated in Figures 10a and 10b, the membrane hinge 26 may extend across the base 12 between two frangible membranes 22. This provides good opening characteristics and is particularly useful for spices and other pourable products.

Figures 11 and 11a illustrate fingers 20 of considerably more span than in many of the other illustrations. In order to achieve such a span without interfering with flexing of the fingers 20 toward the base 12 and to maintain engagement between a lip engaging end 21 of the fingers 20 distal the rim 14, webs 23 are provided. The webs 23 represent a thinner area (i.e. a reduced thickness region) extending toward the rim 14 from the lip engaging end 21. The webs 23 enable the finger 20 to flex in a manner similar to a row of closely spaced individual fingers 20 of lesser span in side by side juxtaposition.

The wider span fingers 20 of the Figures 11 and 11a embodiment may be more prone to retaining moisture between the fingers 20 and the rim 12. Accordingly passages or holes in the form of windows 25 may be provided through the fingers 20 as shown in Figure 11a. The windows 25 are illustrated as being rectangular however any configuration may be used including circular and triangular and combinations of the foregoing.

As illustrated in Figures 12 and 12a, one or more pull tabs 40 may be provided extending from the rim 14 of the lid 10 away from the base 12. The pull tabs 40 assist in tearing of the frangible membranes 22 by providing an

frangible membrane 22 extends from the lower edge 29 about the finger (not illustrated) to the frangible membrane 26. The finger would extend radially inwardly from the tab 24.

Alternatively, as shown toward the right of Figure 16, the tab 24 may be defined by a membrane hinge 26 between the lower edge 29 and the base 12 and a frangible membrane 22 to either side thereof. The frangible membranes 22 extend from the lower edge 29 to the membrane hinge 26.

As a safety precaution it is desirable to avoid sharp edges upon tearing of the frangible membranes 22. One way of achieving this, as illustrated in Figure 17, is to provide a chamfer 52 extending into the rim 14 from its lower edge 29 at the juncture of the frangible membrane 22 and the lower edge 29. The chamfer will avoid a sharp point in the torn frangible membrane 22. Different arrangements of the membrane hinge 26 and the frangible membranes 22 are illustrated in Figure 17 in association with the chamfer 52.

Referring to Figure 18, an alternative embodiment of the lid 10 has the rim 14 extending around the periphery of the base 12 and depending from the base 12 to the lower edge 29. A series of the tabs 24 are located at spaced locations around the rim 14 for indicating the sealing state of the lid 10 when mounted on the container 13 (see Figure 5), i.e. either previously opened or unopened. The tabs 24 have adjacent frangible membranes 22, situated adjacent to each of the fingers 20, between a main sidewall 25 of the rim 14 and the tabs 24. The frangible membranes 22 extend between the lower edge 29 of the rim 14 and the base 12. The inwardly extending ribs or undercuts 50 have extending portions 60 that extend past the membranes 22 and overlap onto the underside of the tabs 24, while leaving sufficient spacing for the fingers 20 as an interrupted portion 62 between adjacent ones of the extending portions 60. The interrupted portions 62 allow the fingers 20 to flex outwardly towards the retracted position against the inside of the rim 14. It is noted that the tabs 24 have a first tab portion 24a including the overlapped extending portions 60, and a second tab portion 24b positioned between the

first tab portion 24a and the lower edge 29 of the rim 14. Further, the lid 10 can also have vertical ribs 74 positioned on the first tab portion 24a to help alleviate bounce on the spin bars (not shown) during manufacture of the lid 10.

5 Referring to Figure 19, in operation of the lid 10, the extending portions 60 interrupt the tearing of the frangible membranes 22, such that the second tab portion 24b separates from the main sidewall 25 of the rim 14, while the first tab portion 24a remains attached thereto. The extending portions 60 of the rib 50 provide tear resistance of the membranes 22, such that only part of
10 the membranes 22 tears adjacent to the second tab portion 24b. This partial tearing of the membrane 22 helps to maintain the integrity of the rim 14 between the ribs 50 and the base 12, such that the lid 10 once opened can be resealed onto the container 13 (see Figure 5).

Referring to Figure 20, it can be seen that the first tab portion 24a is
15 thinner in cross section than that of the second tab portion 24b, thereby defining an offset sidewall that provides an offset hinge 64. It is recognised that positioning of the offset hinge 64 between the portions 24a and 24b helps to promote bending of the tab portion 24b to one side of the extending portions 60, providing a means for the finger 20 of the tab portion 24b to
20 remain positioned away (see ghosted view) from the sidewall 30 of the container 13 (see Figure 5) once the membranes 22 are partially broken during opening of the lid 10. Further, it can be seen that a local pocket 66 is provided by the first tab portion 24a between adjacent sections of the sidewall 25 (seeFigure19).

25 Referring to Figures 6 and 20, it is recognised that forming the frangible membranes 22 from the lower edge 29 to the base 12 helps to provide for moulding efficiencies, such as but not limited to reducing the need for slider mould mechanisms (as is known in the art) as compared to forming piecewise membranes 22 (see Figures 16 and 17) partway in the rim 14, which extend
30 from the lower edge 29 to approximately midway to the hinge 26. Further, it

is recognised that the offset sidewall of the tab 24 can help to position ejection forces of the moulding process away from the ribs 50.

Referring to Figure 21, an alternative embodiment of the lid 10 is shown having both the offset tab 24 and an offset sidewall 25, which consists of a first sidewall portion 25a and a second offset sidewall portion 25b. Provision of the adjacent tab portions 24a,b and sidewall portions 25a,b gives a continuous offset around the rim 14. For example, the outside surfaces of the tab portions 24a,b and the respective sidewall portions 25a,b can be flush with one another on either side of the intervening membrane 22.

Referring to Figure 22, it is noted that the inside wall of the rim 14 has an inset region 68 located between the tab portions 24a,b to help maintain consistency of the thickness of the rim 14. A tapered transition portion 70 positioned to either side of the tab 24 helps to locally stiffen the connection between the tab portions 24a,b (i.e. offset hinge 64) to help maintain the structural integrity of the lid 10 when installed on the container 13 (see Figure 5), as well as to help transfer ejection forces from the lower edge 29 to eject over the rib 50 and rib extending portions 60. The lid 10 also has an angled abutment member 72 located adjacent to the lower edge 29 and oriented radially inwards from the inside surface of the rim 14. The angled abutment member 72 increases the thickness of the rim 14 near the lower edge 29, thereby helping to increase a tendency for toe-in of the lower edge 29 (warping of the lower edge 29 radially inwards) during cooling of the lid 10 in the moulding process. Further, the abutment member 72 can also enhance stackability of the lid 10 by providing a thicker lower edge 29 for placement on the base 12 of an adjacent lid 10 (not shown), outwardly of the stacking ring 46.

Accordingly, the lid 10 of Figures 18 to 22 includes an offset tab 24 (and optional offset sidewall 25) configuration for providing an offset hinge 64 at the point of offset. The extending portions 60 overlap the first tab portions 24a to interrupt the rupture of the frangible membranes 22, such that the

membrane 22 tearing is inhibited from damaging the integrity of the rim 14 between the ribs 50 and the base 12. The thickness of the ribs 50 and corresponding extending portions 60 are sufficient to resist tear continuation of the membrane 22 past the ribs 50, and therefore restrict or otherwise
5 localise separation of the tabs 24 from the sidewall 25 primarily to the second tab portions 24b. Maintaining integrity of the rim 14 near the base 12 helps to provide a resealing capability to the lid 10 once opened.

Referring to Figure 23, an alternative embodiment of lid 10 is shown in a rectangular (or square) configuration. The lid 10 can also have vertical ribs
10 74 positioned on the first tab portion 24a.

The above description is intended in an illustrative rather than a restrictive sense. Variations may be apparent to those skilled in the relevant art without departing from the spirit and scope of the invention as defined by the claims set out below:

WE CLAIM:

1. A tamper evident lid for mounting over an opening of a container having sidewalls with a lip extending outwardly therefrom to define said opening, said lid comprising:

a base;

a rim extending about said base for receiving said lip;

at least one resiliently flexible finger extending inwardly from said rim for engaging said lip, each said at least one finger having a length exceeding the distance between and inside of said lip and said sidewall and extending toward said base when said lid is mounted on said container; and,

at least one frangible membrane formed in said rim and associated with at least one said finger for facilitating tearing of said rim to disengage said at least one said finger from said lip to enable removal of said lid from said container while leaving evidence of removal by way of a torn frangible membrane.

2. The tamper evident lid of claim 1 wherein:

said rim has an upper end adjacent to said base and a lower edge distal to said base; and

said frangible membrane extends from said lower edge toward said upper end.

3. The tamper evident lid of claim 1 wherein:

a respective of said frangible membrane is disposed on opposite sides of at least one said finger.

4. The tamper evident lid of claim 2 wherein:

at least a pair of said fingers is provided; and,

each one of said pair of fingers is disposed on an opposite side of said frangible membrane.

5. The tamper evident lid of claim 3 wherein:

said frangible membrane extends to a membrane hinge formed in at least one of said rim and said base; and,

said membrane hinge is positioned to facilitate disengagement of said at least one said finger from said lip upon tearing of said frangible membrane.

6. The tamper evident lid of claim 5 wherein:

said at least one said finger is disposed between said membrane hinge and said lower edge.

7. The tamper evident lid of claim 2 wherein:

said frangible membrane extends to at least one membrane hinge formed in said rim;

each said at least one membrane hinge extends from said lower edge toward said base; and,

said at least one said finger is disposed in an area bordered by said frangible membrane, one of said at least one membrane hinge and said lower edge.

8. The tamper evident lid of claim 4 wherein:

said pair of fingers is disposed between a pair of membrane hinges extending from said lower edge toward said base; and,

each said frangible membrane extends from said lower edge to each one of said pair of membrane hinges; and,

each said one of said fingers is disposed in an area bordered by said at least part of said frangible membrane, said membrane hinge and said lower edge.

9. The tamper evident hinge of claim 2 wherein:

a pair of radially spaced apart of said frangible membranes is provided with at least one of said at least one finger, disposed therebetween; and,

a membrane hinge extends across said base between said frangible membranes to facilitate disengagement of said fingers from said lip upon tearing of said frangible membranes by bending a portion of said base away from said lip.

10. The tamper evident hinge of claim 9 wherein:

a plurality of said fingers are disposed between said frangible membranes.

11. The tamper evident lid of claim 2 wherein:

at least one of said at least one fingers is a webbed finger having at least one web defined by a reduced thickness region extending toward said rim from a lip engaging end of said webbed finger which is distal said rim.

12. The tamper evident lid of claim 11 wherein:

each said webbed finger is provided with a passage therethrough in the form of a window to promote drainage of fluid trapped between said webbed finger and said rim.

13. The tamper evident lid of claim 1 wherein:

each said at least one finger has a profile selected from the group consisting of rounded, parallel faced straight, tapered narrowing toward said rim and tapered narrowing toward said rim with a scallop facing said container at an outer end thereof distal said rim.

14. The tamper evident lid of claim 13 wherein:

each said finger is curved in a direction generally corresponding to a curvature of said container to provide a lengthened contact zone with said lip.

15. The tamper evident lid of claim 13 wherein:

said rim has a recess extending from said fingers to said lower edge to accommodate said fingers to facilitate stripping of said lid in an injection moulding process.

16. The tamper evident lid of claim 13 wherein:

said fingers extend from said lower edge of said rim.

17. The tamper evident lid of claim 2 wherein:

from six to eight tear tabs are provided.

18. The tamper evident lid of claim 6, 7 or 8 wherein:

at least one pull tab extends from said lower edge of said rim to facilitate tearing of at least one said frangible membrane.

19. The tamper evident lid if claim 18 wherein:

a stacking ring extends about said base and away from said rim to engage said lower edge of an adjacent of said tamper evident lid stacked thereupon to resist lateral shifting therebetween; and,

said stacking ring is one of segmented and continuous.

20. The tamper evident lid of claim 19 wherein:

a chamfer extends into said rim from said lower edge at the juncture of said frangible membranes and said lower edge to avoid a sharp corner at said juncture upon tearing of said frangible membrane.

21. The tamper evident lid of claim 2 further comprising a respective of said frangible membrane dispensed on opposite sides of at least one of said finger to provide a tab portion partially detachable from a sidewall portion of the rim.

22. The tamper evident lid of claim 21, wherein the tab portion further comprises a first tab portion depending from said upper end and a second tab portion depending from said first tab portion toward said lower edge, said second tab portion is a detachable from the sidewall portion.

23. The tamper evident lid of claim 22 further comprising a rib extending inwardly from the sidewall portion of the rim, the rib having an extension portion overlapping both said first tab portion and an adjacent one of the frangible membranes, the extension portion for inhibiting tearing of the adjacent frangible membrane associated with the first tab portion.

24. The tamper evident lid of claim 23, wherein the rib and the extension portion are configured for engaging said lip to retain said lid on said container once mounted thereon.

25. The tamper evident lid of claim 23, wherein respective extension portions overlap said first tab portion and each of the adjacent frangible membranes on opposite sides of the first tab portion to inhibit tearing of the adjacent frangible membranes associated with the first tab portion.

26. The tamper evident lid of claim 25 further comprising an interrupted portion located between the extending portions for allowing said finger to flex outwardly towards a retracted position against the inner surface of the tab portion.

27. The tamper evident lid of claim 22 further comprising an offset wall between said first tab portion and said second tab portion to define an offset hinge, the offset hinge for promoting bending of the tab portion between the first and second tab portions upon tearing of the said frangible membranes.

28. The tamper evident lid of claim 27, wherein respective extension portions overlap the adjacent said frangible membranes on opposite sides of the first tab portion to inhibit tearing of the adjacent said frangible membranes associated with the first tab portion.

AMENDED CLAIMS

[Received by the International Bureau on 01 December 2003 (01.12.03):
original claims 1-4 and 23-28 replaced by amended claims 1-4 and 23-29 (2 pages)]

1. A tamper evident lid for mounting over an opening of a container having sidewalls with a lip extending outwardly therefrom to define said opening, said lid comprising:

a base;

a rim extending about said base for receiving said lip;

at least one resiliently flexible finger extending inwardly from said rim for engaging said lip, each said at least one finger having a length exceeding the distance between and inside of said lip and said sidewall and extending toward said base when said lid is mounted on said container; and,

at least one pair of frangible membranes spaced apart and formed in said rim and associated with the at least one finger for facilitating tearing of said rim to disengage the at least one finger from said lip to enable removal of said lid from said container while leaving evidence of removal by way of torn frangible membranes, the at least one finger disposed between the at least one pair of frangible membranes.

2. The tamper evident lid of claim 1 wherein:

said rim has an upper end adjacent to said base and a lower edge distal to said base; and

said frangible membrane extends from said lower edge toward said upper end.

3. The tamper evident lid of claim 1 wherein:

a respective of said frangible membrane is disposed on opposite sides of at least one said finger.

4. The tamper evident lid of claim 2 wherein:

at least a pair of said fingers is provided; and,

AMENDED SHEET (ARTICLE 19)

23. The tamper evident lid of claim 22 further comprising a rib extending inwardly from the sidewall portion of the rim, the rib having an extension portion overlapping both said first tab portion and an adjacent one of the frangible membranes, the extension portion for inhibiting tearing of the adjacent frangible membrane associated with the first tab portion.

24. The tamper evident lid of claim 23, wherein the rib and the extension portion are configured for engaging said lip to retain said lid on said container once mounted thereon.

25. The tamper evident lid of claim 23, wherein respective extension portions overlap said first tab portion and each of the adjacent frangible membranes on opposite sides of the first tab portion to inhibit tearing of the adjacent frangible membranes associated with the first tab portion.

26. The tamper evident lid of claim 25 further comprising an interrupted portion located between the extending portions for allowing said finger to flex outwardly towards a retracted position against the inner surface of the tab portion.

27. The tamper evident lid of claim 22 further comprising an offset wall between said first tab portion and said second tab portion to define an offset hinge, the offset hinge for promoting bending of the tab portion between the first and second tab portions upon tearing of the said frangible membranes.

28. The tamper evident lid of claim 27, wherein respective extension portions overlap the adjacent said frangible membranes on opposite sides of the first tab portion to inhibit tearing of the adjacent said frangible membranes associated with the first tab portion.

29. The tamper evident lid of claim 2, wherein a pair of the fingers is disposed between the pair of frangible membranes.

AMENDED SHEET (ARTICLE 19)

1/18

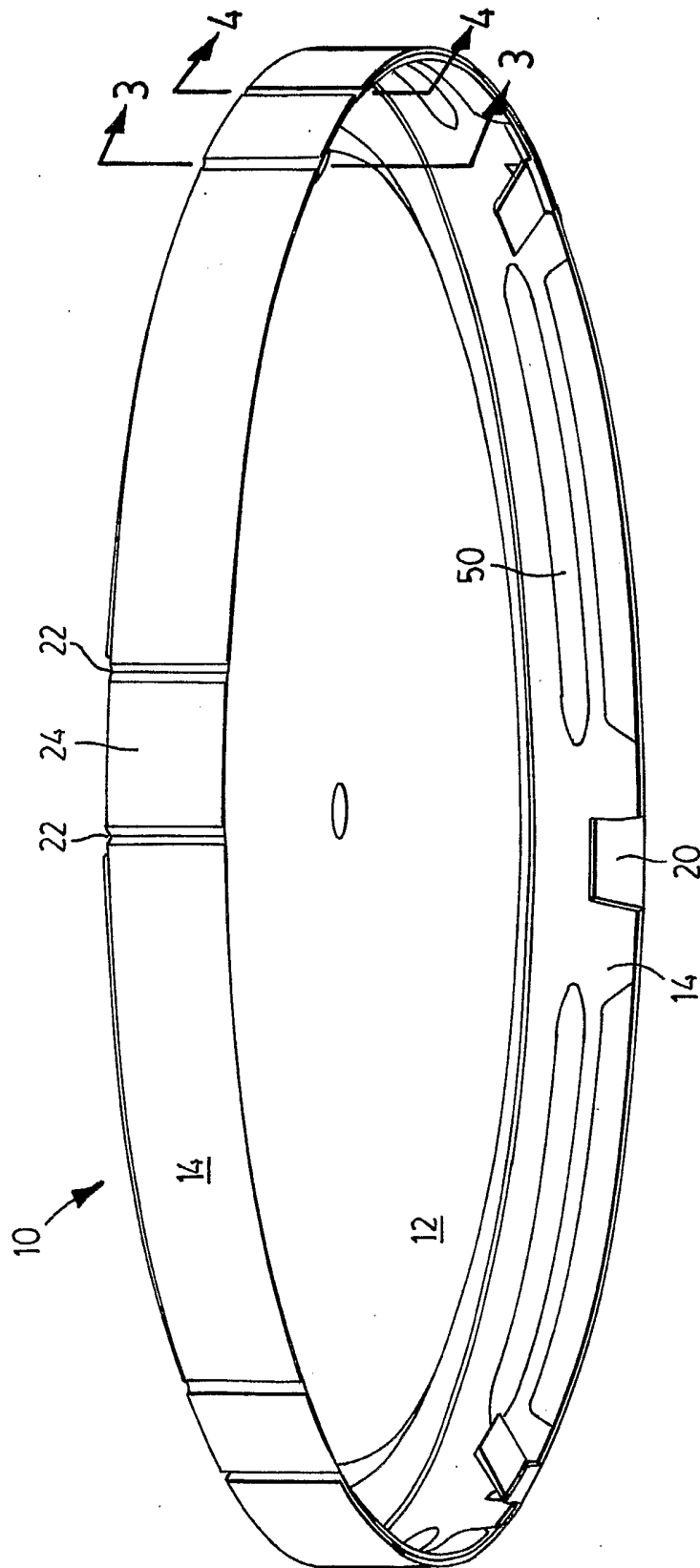

FIG.1

2/18

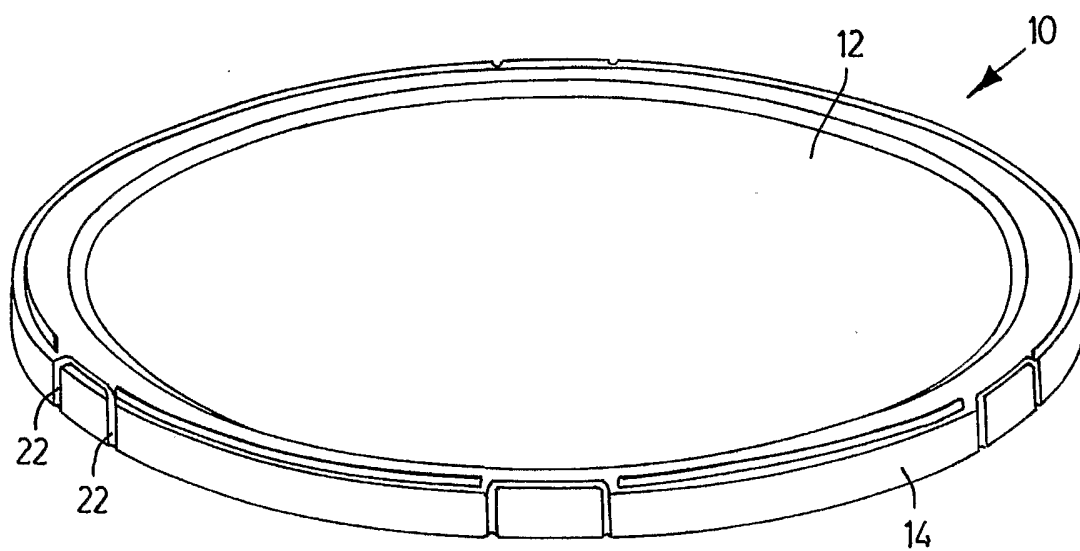

FIG. 2

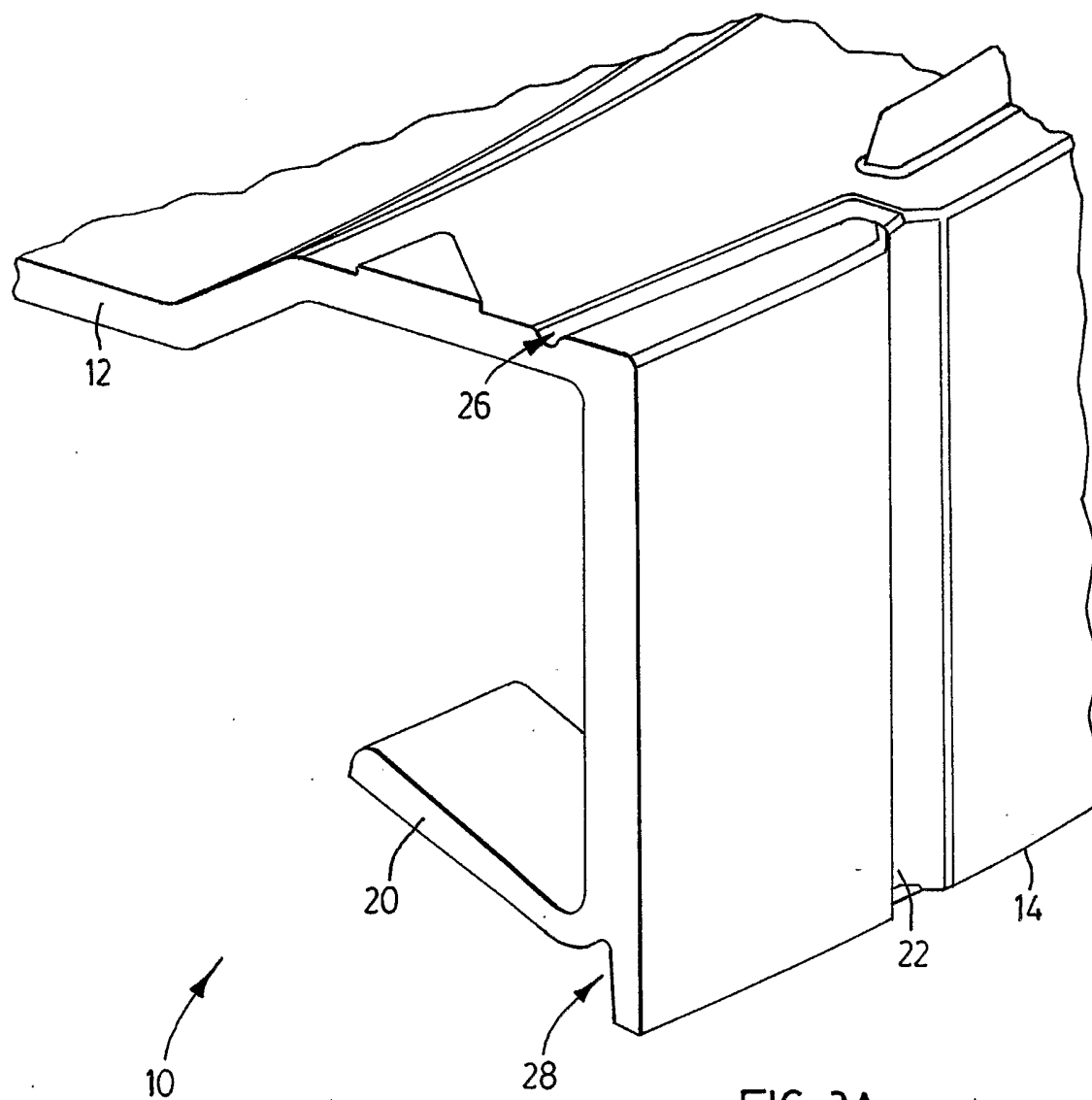

FIG. 3A

4/18

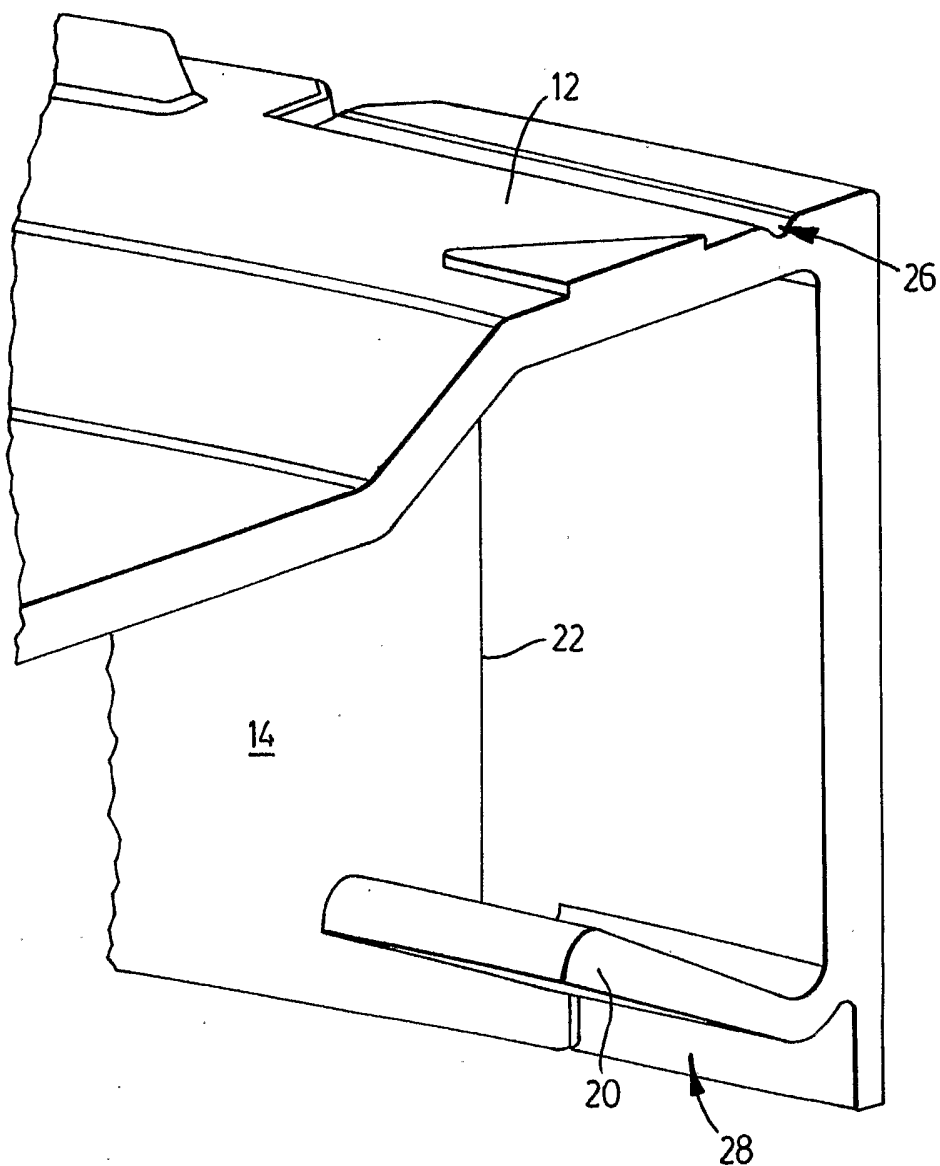
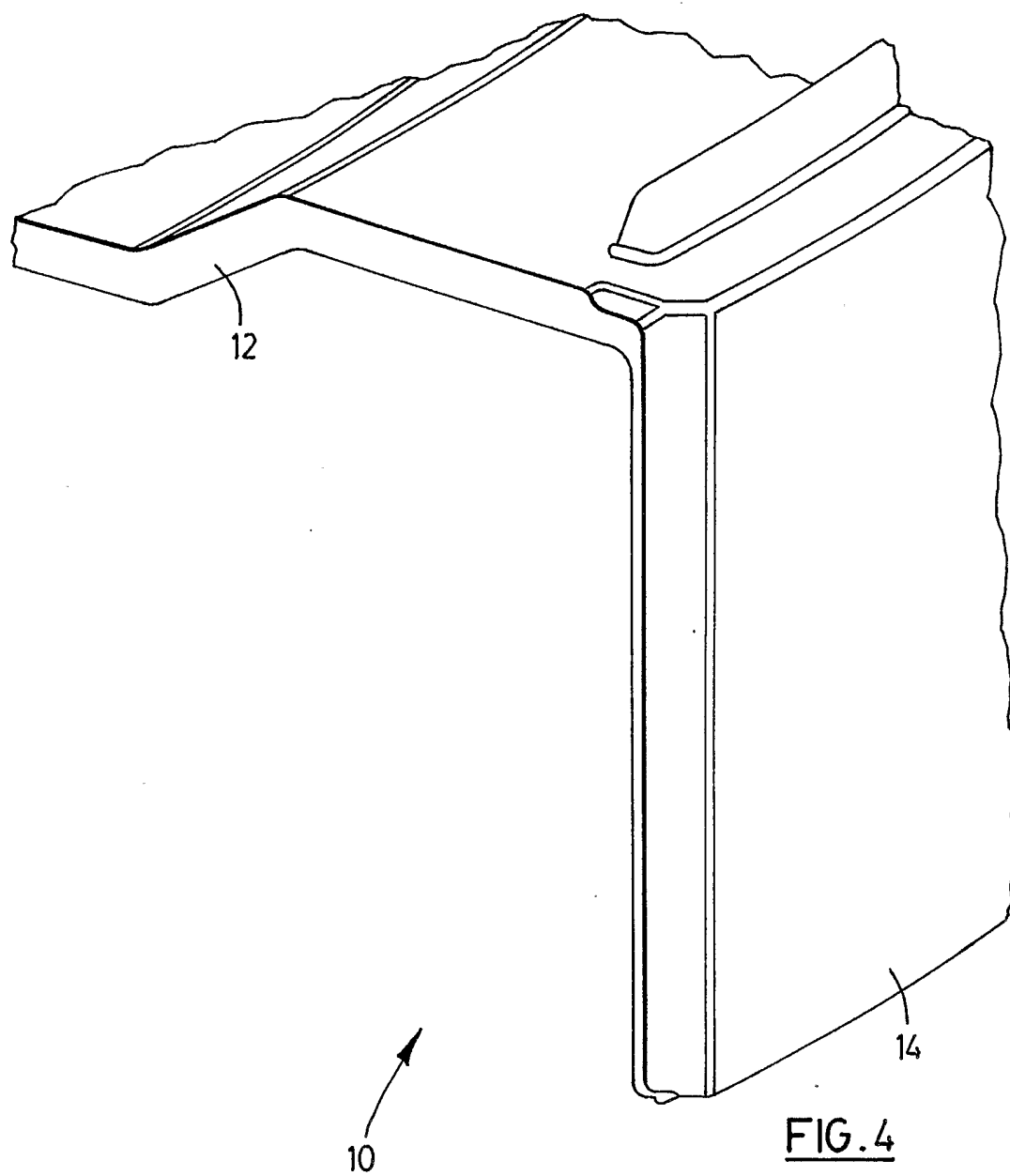
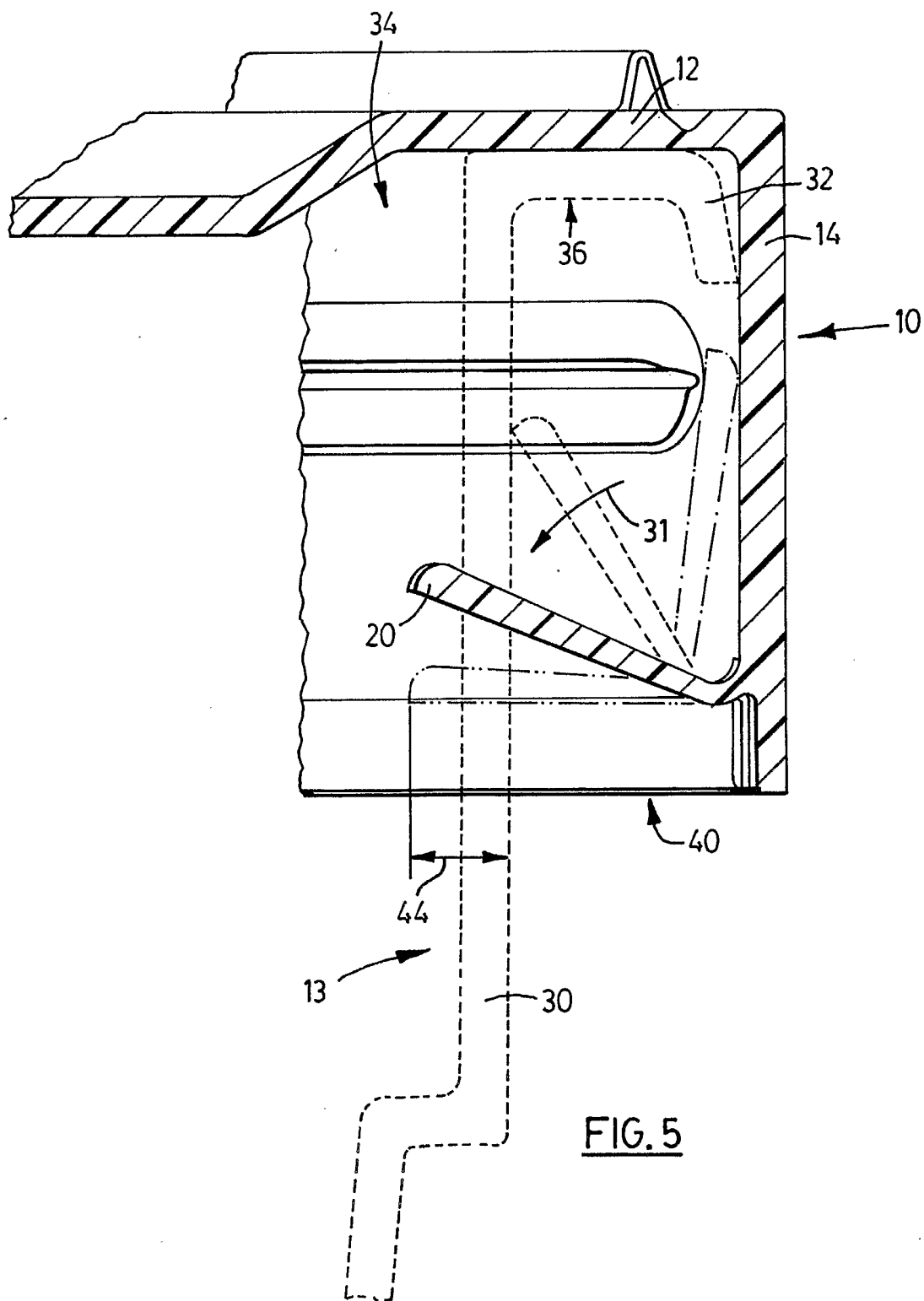

FIG. 3B

5/18



6/18



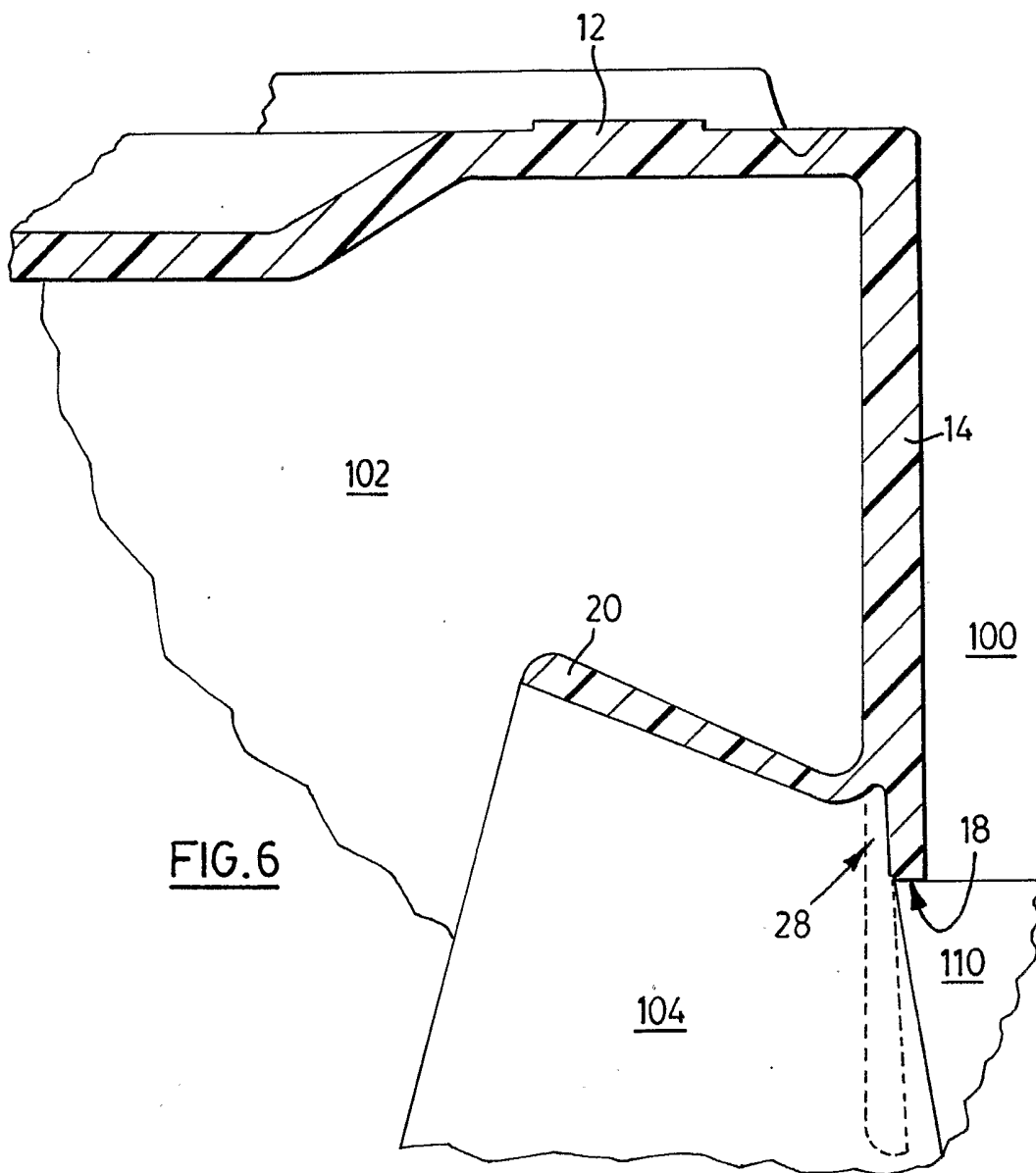

8/18

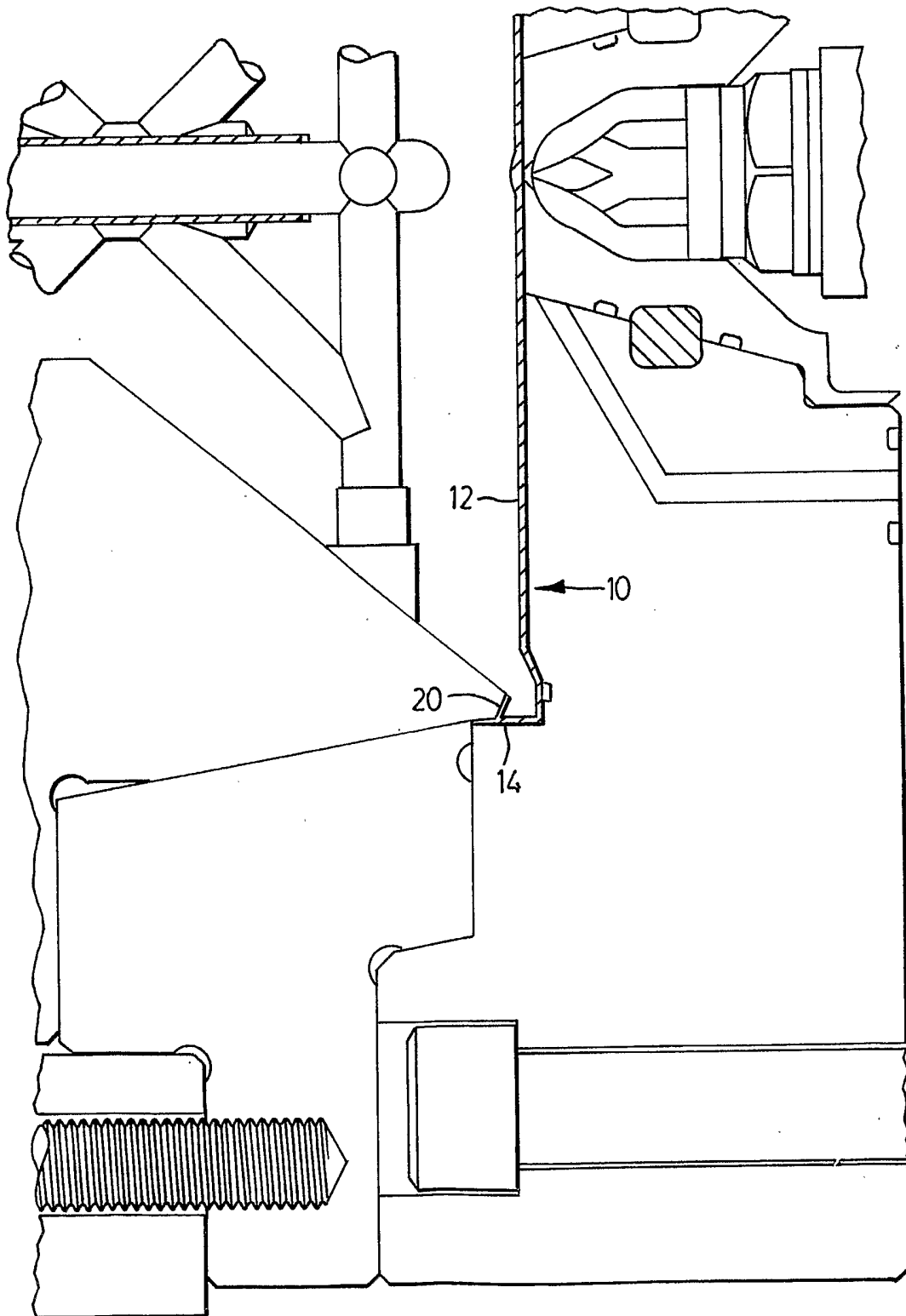

FIG. 7

9/18

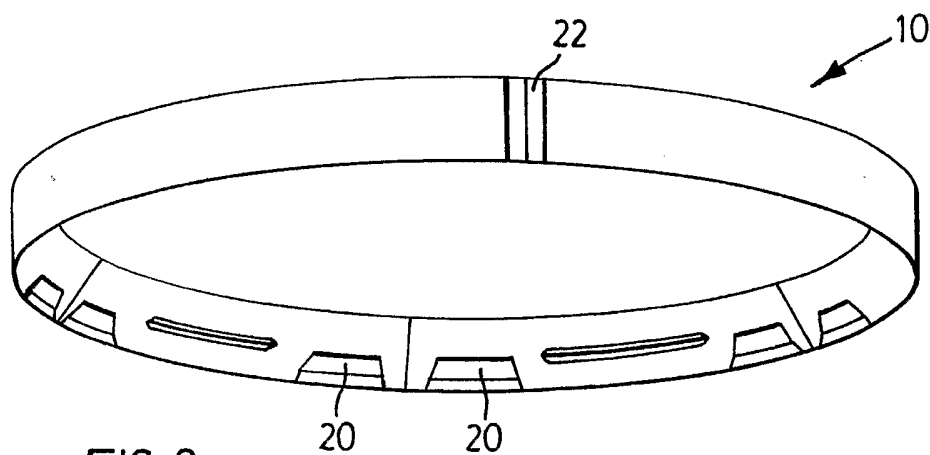

FIG. 8

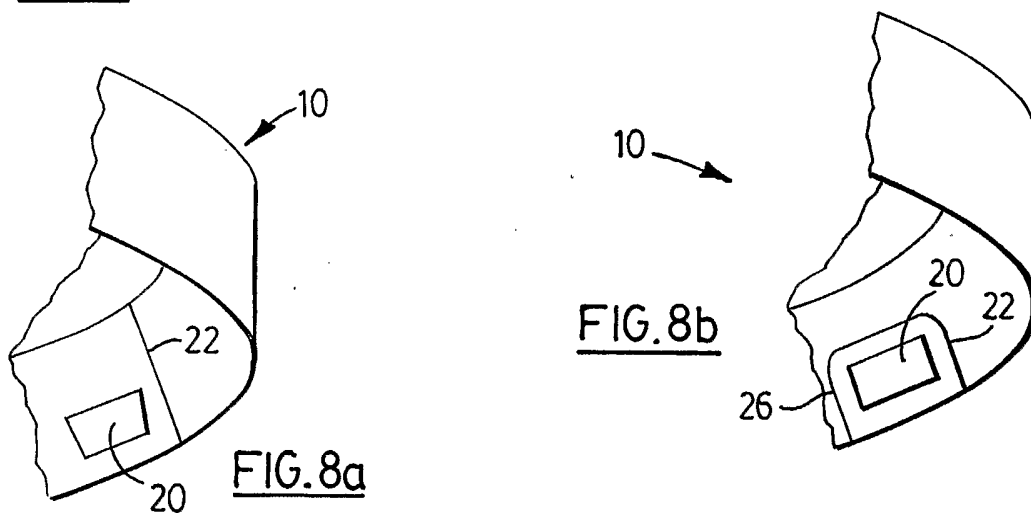

FIG. 8a

FIG. 8b

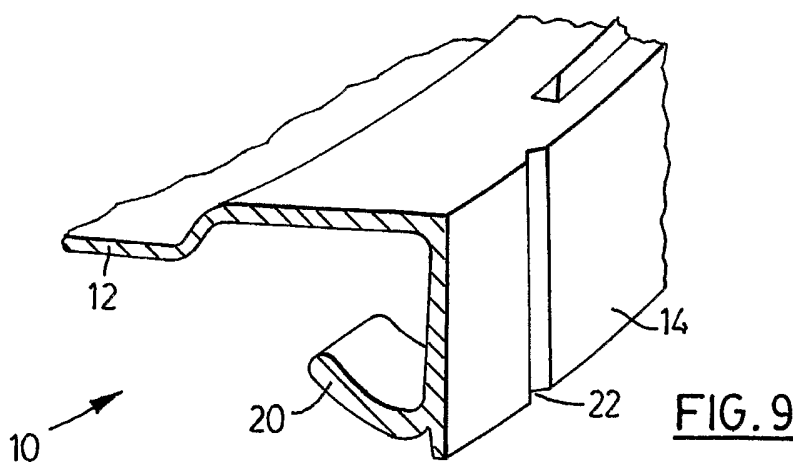
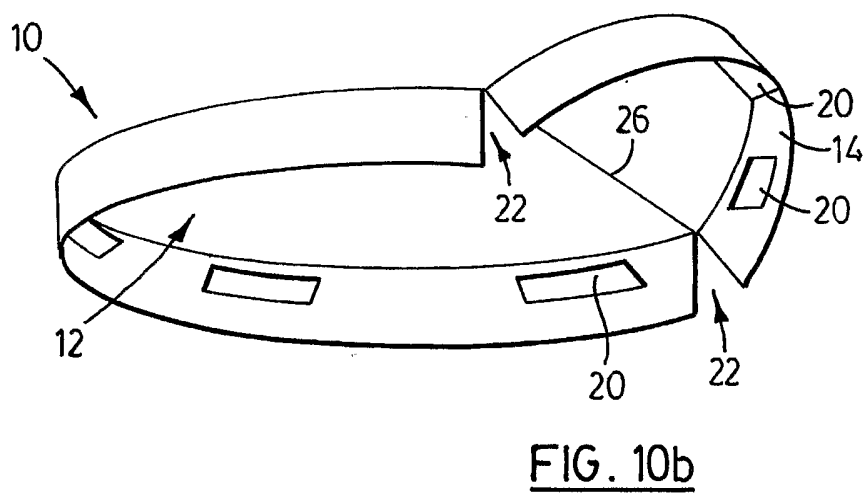
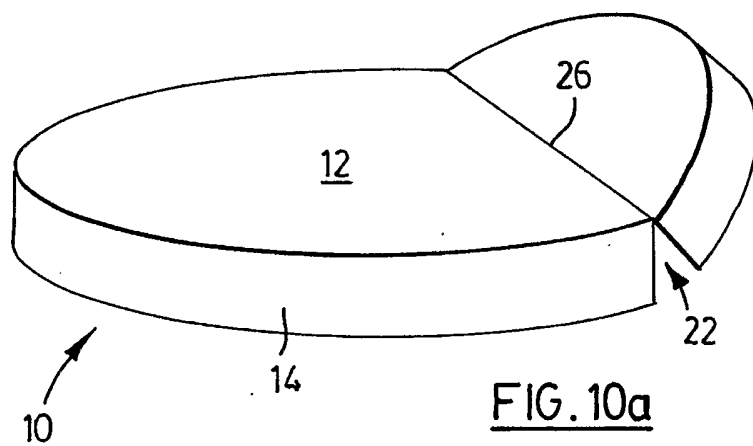
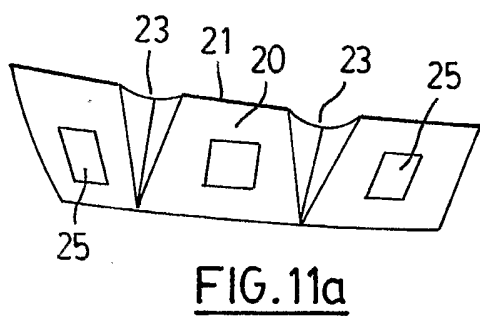
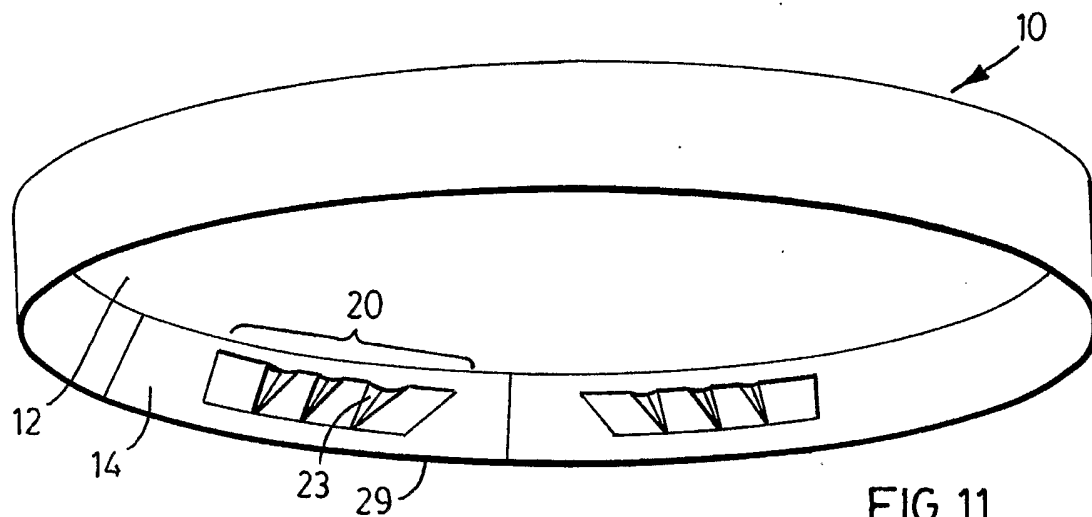

FIG. 9



11/18



12/18

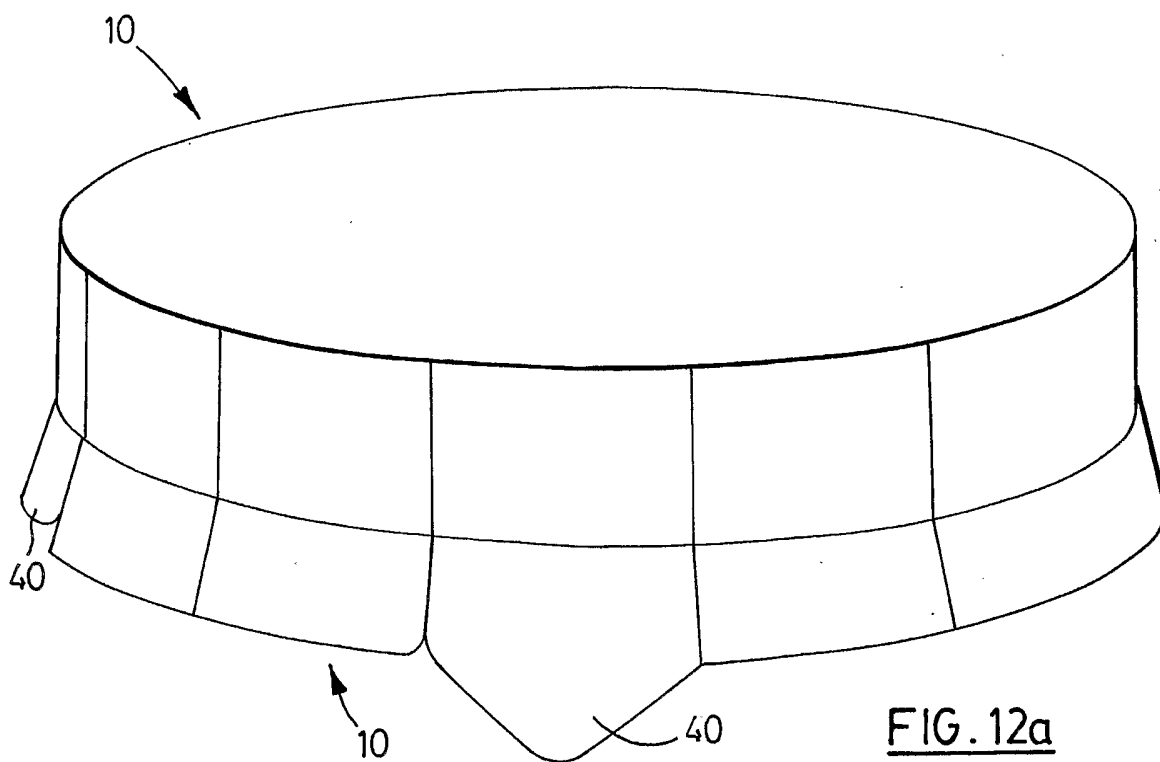
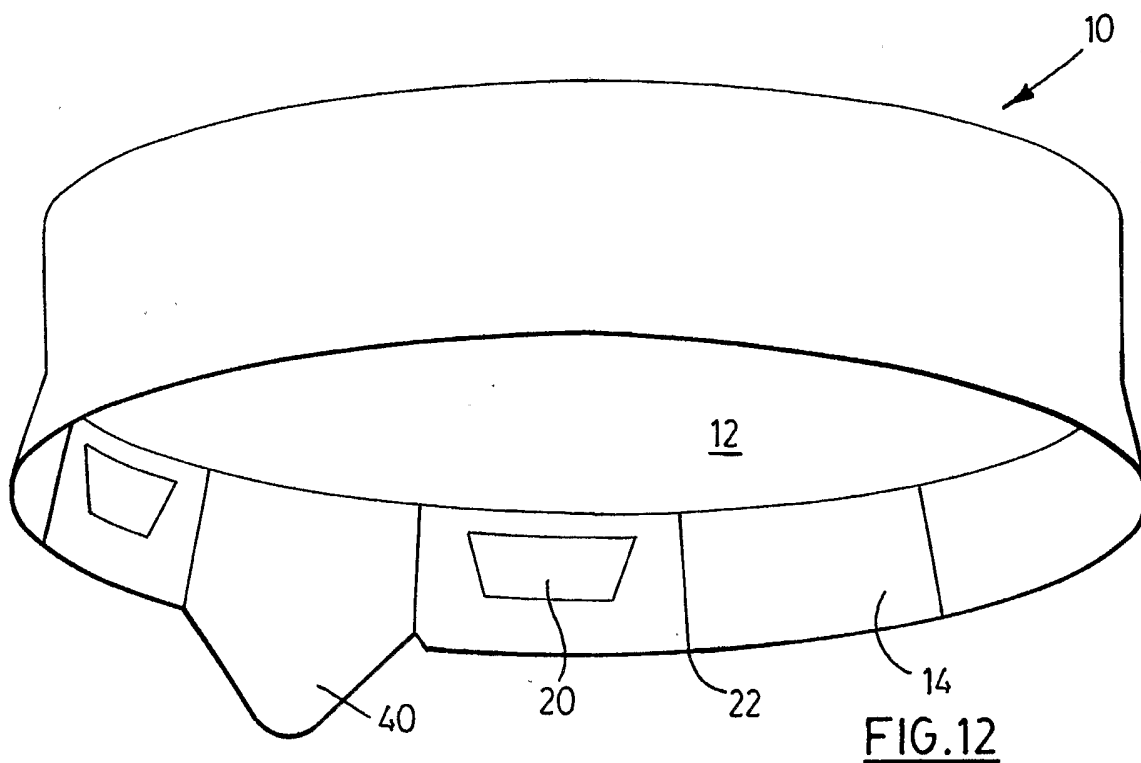

13/18

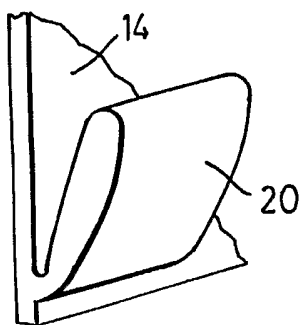

FIG. 13a

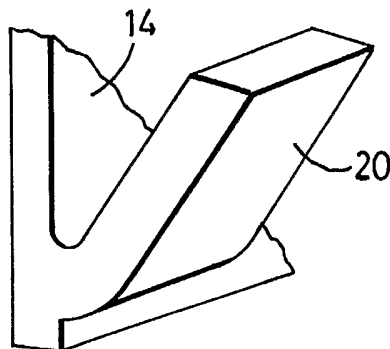

FIG. 13b

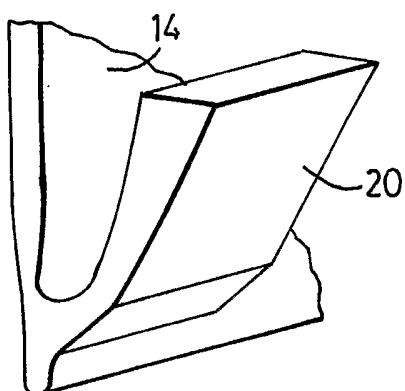

FIG. 13c

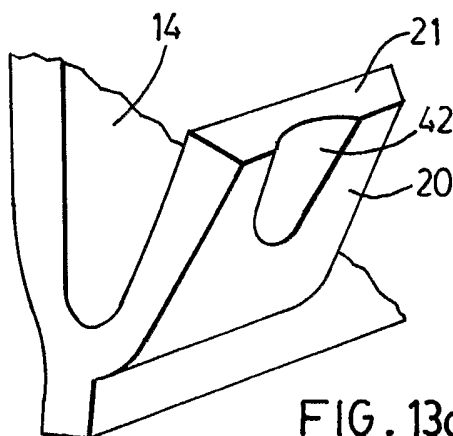

FIG. 13d

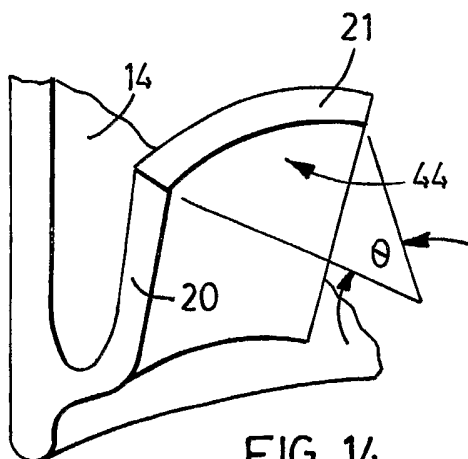

FIG. 14

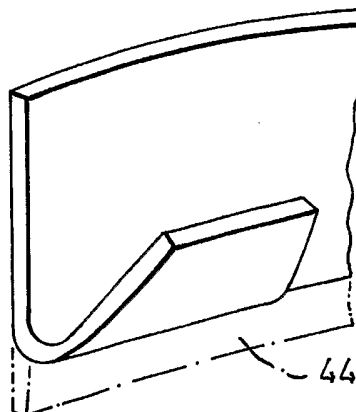

FIG. 15

14/18

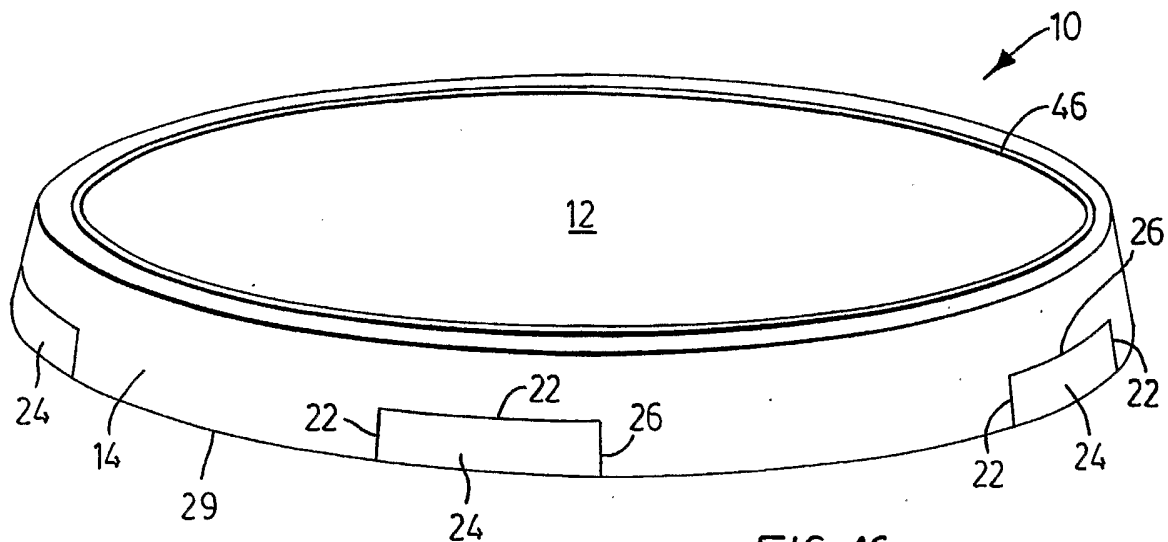

FIG. 16

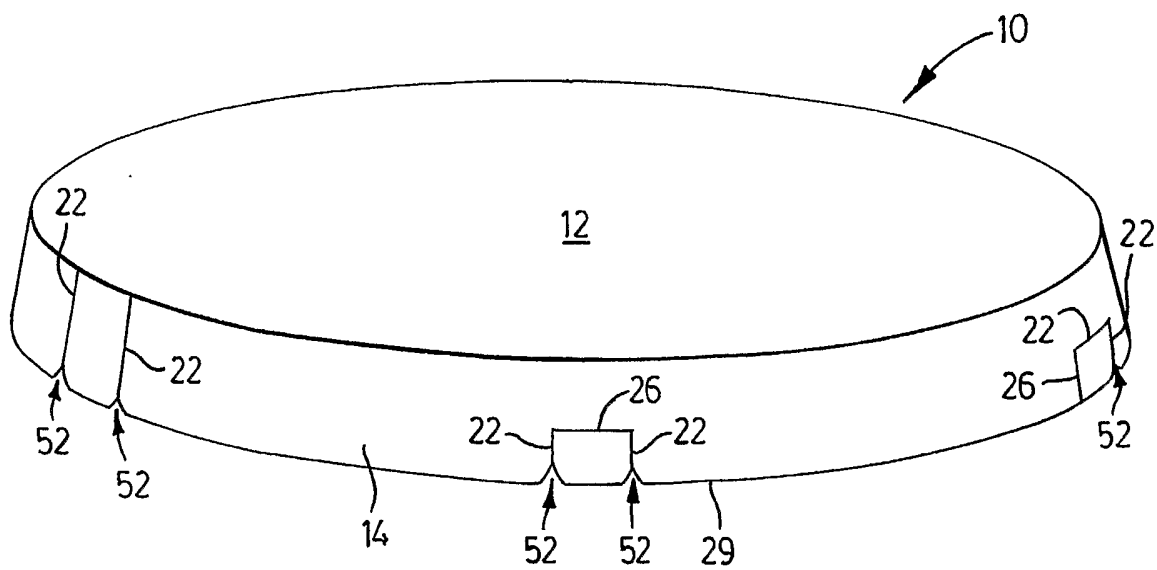

FIG. 17

15/18

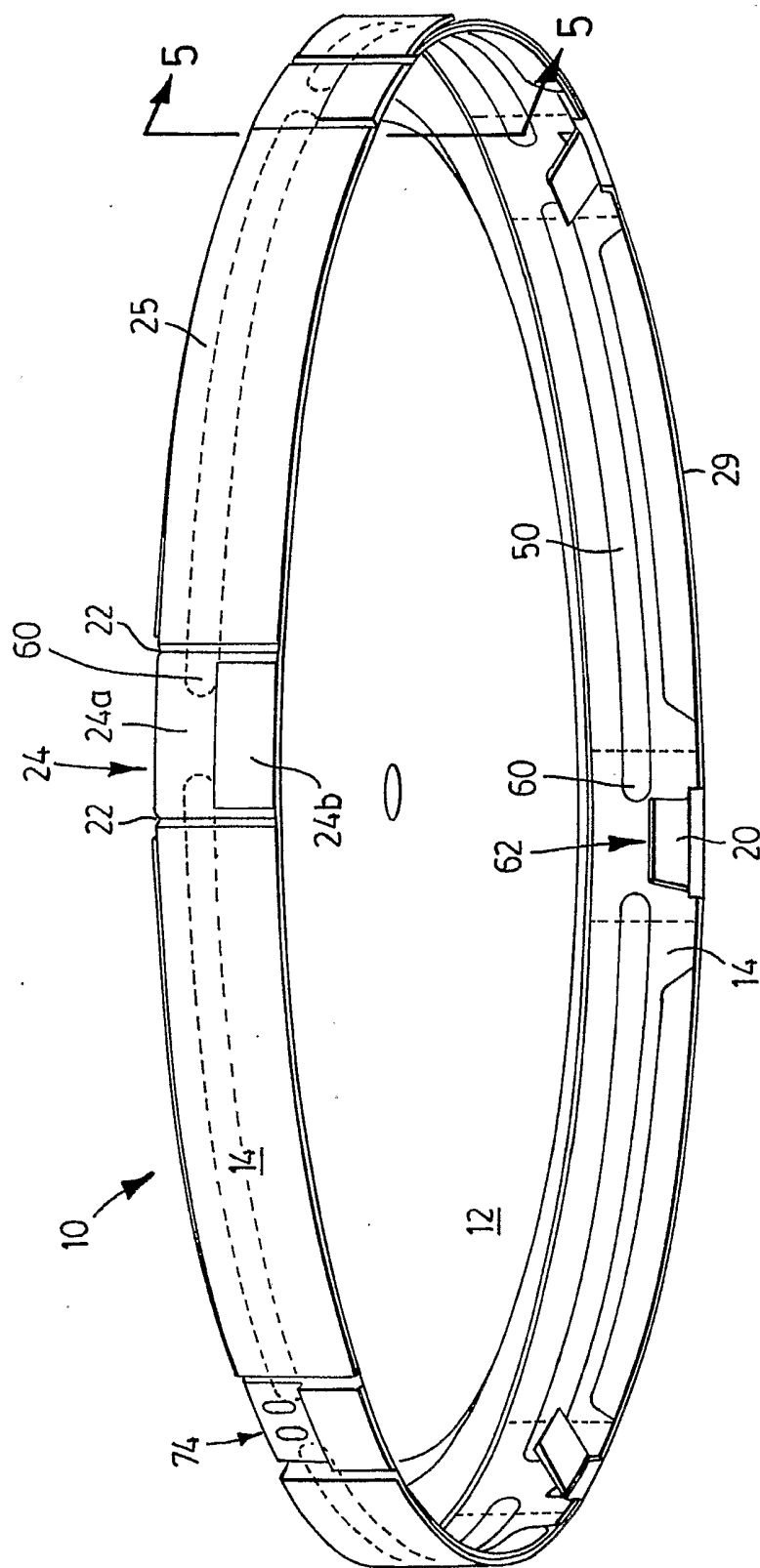

FIG. 18

16/18

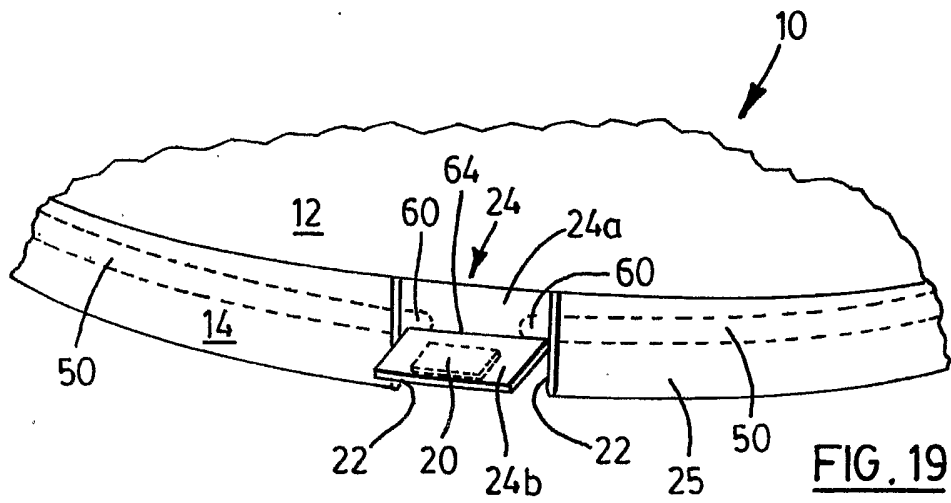

FIG. 19

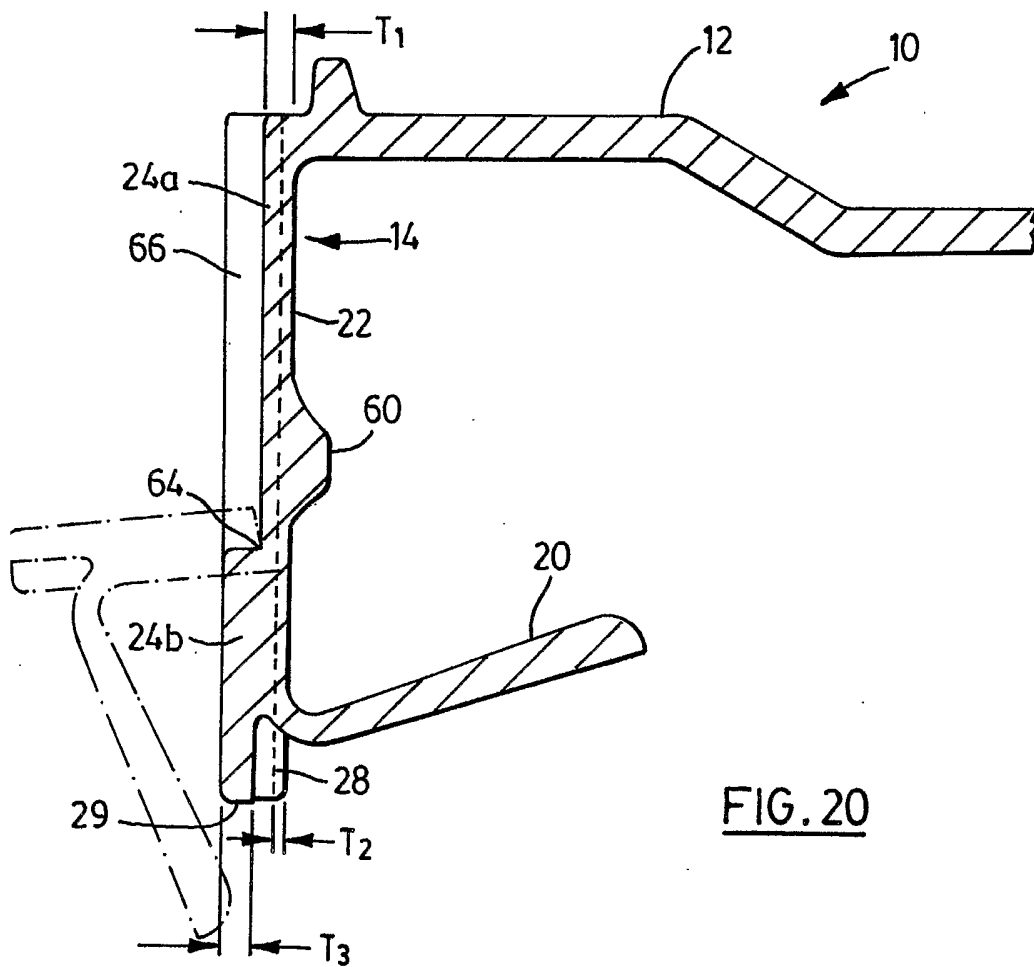

FIG. 20

17/18

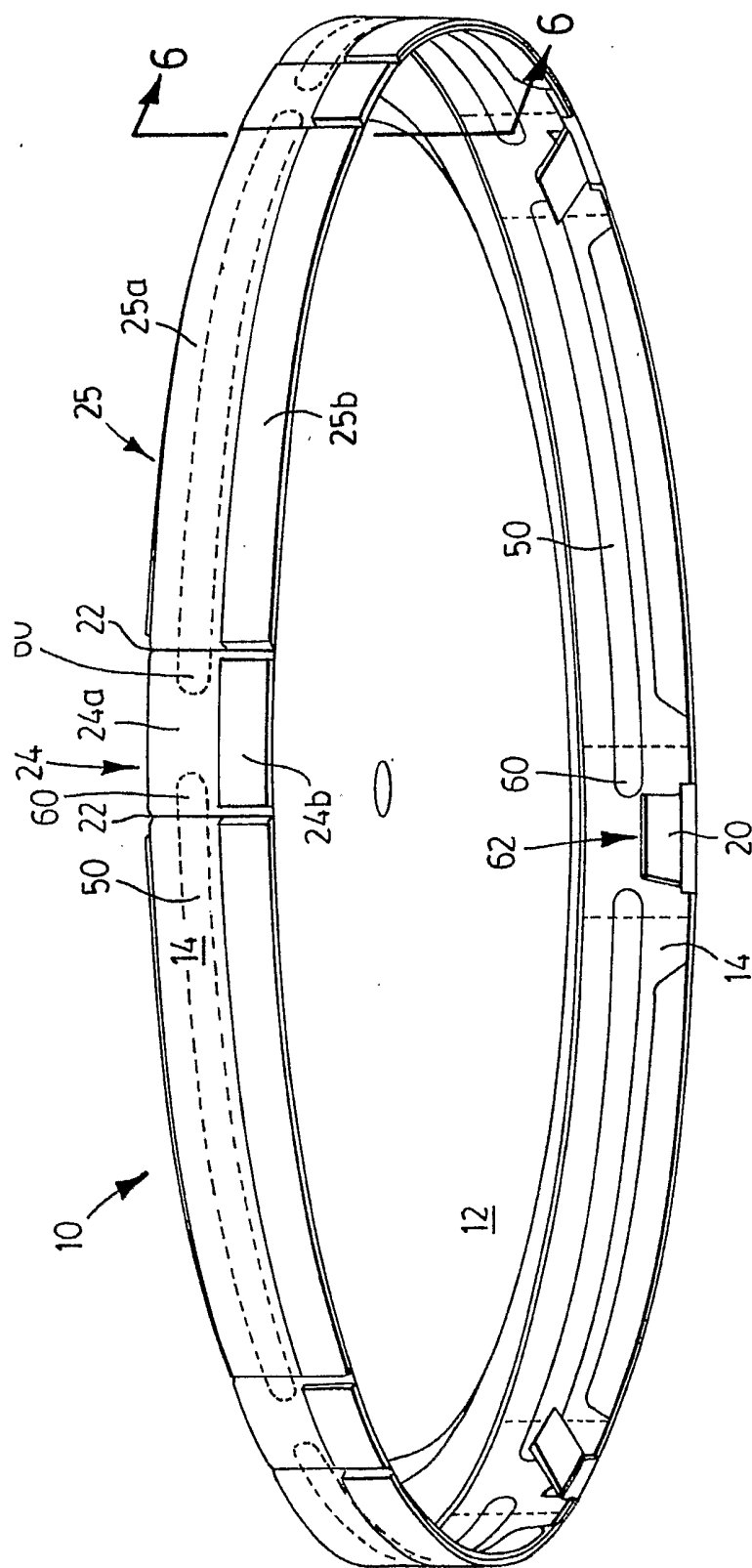

FIG. 21

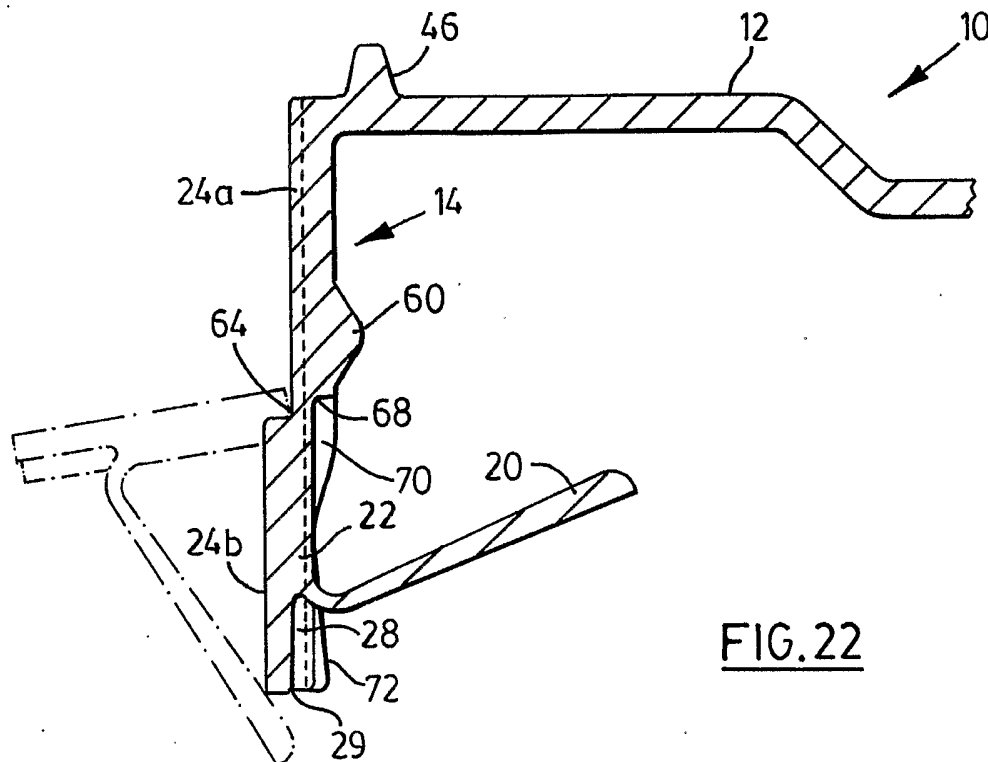

FIG. 22

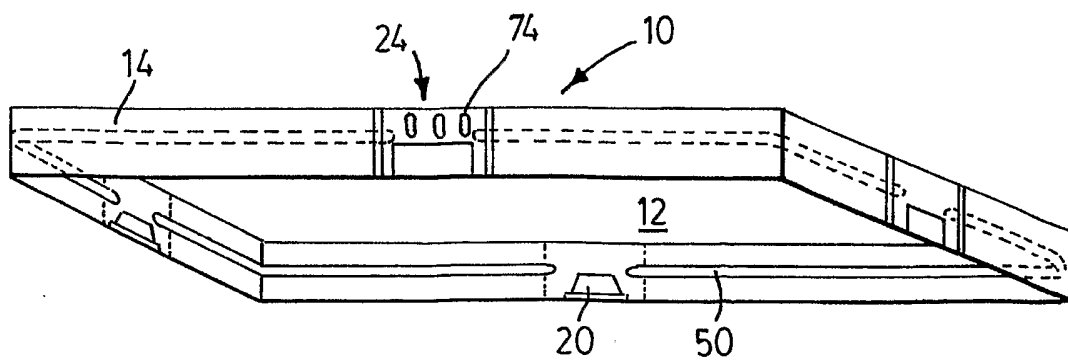

FIG. 23

INTERNATIONAL SEARCH REPORT

International Application No

PCT/CA 03/00949

A. CLASSIFICATION OF SUBJECT MATTER

IPC 7 B65D43/02

According to International Patent Classification (IPC) or to both national classification and IPC

B. FIELDS SEARCHED

Minimum documentation searched (classification system followed by classification symbols)

IPC 7 B65D

Documentation searched other than minimum documentation to the extent that such documents are included in the fields searched

Electronic data base consulted during the international search (name of data base and, where practical, search terms used)

PAJ

C. DOCUMENTS CONSIDERED TO BE RELEVANT

Category *	Citation of document, with indication, where appropriate, of the relevant passages	Relevant to claim No.
X	US 5 540 342 A (RATHBUN WILLARD J) 30 July 1996 (1996-07-30) column 2, line 45 -column 3, line 39 figures 2,3,8	1,2,4, 13,14,19
Y	---	11,17, 18,20
X	JP 10 218209 A (SATO SHOSAN:KK) 18 August 1998 (1998-08-18) figures 1,2	1,13,16
Y	---	17,18
Y	US 5 725 115 A (BOESL UDO ET AL) 10 March 1998 (1998-03-10) column 6, line 25-38 figures 5,6	11
A	---	1
	-/--	

 Further documents are listed in the continuation of box C. Patent family members are listed in annex.

* Special categories of cited documents :

- *A* document defining the general state of the art which is not considered to be of particular relevance
- *E* earlier document but published on or after the international filing date
- *L* document which may throw doubts on priority claim(s) or which is cited to establish the publication date of another citation or other special reason (as specified)
- *O* document referring to an oral disclosure, use, exhibition or other means
- *P* document published prior to the international filing date but later than the priority date claimed

- *T* later document published after the international filing date or priority date and not in conflict with the application but cited to understand the principle or theory underlying the invention
- *X* document of particular relevance; the claimed invention cannot be considered novel or cannot be considered to involve an inventive step when the document is taken alone
- *Y* document of particular relevance; the claimed invention cannot be considered to involve an inventive step when the document is combined with one or more other such documents, such combination being obvious to a person skilled in the art.
- *&* document member of the same patent family

Date of the actual completion of the international search

8 September 2003

Date of mailing of the international search report

16/09/2003

Name and mailing address of the ISA

European Patent Office, P.B. 5818 Patentlaan 2
NL - 2280 HV Rijswijk
Tel. (+31-70) 340-2040, Tx. 31 651 epo nl,
Fax: (+31-70) 340-3016

Authorized officer

Kakoullis, M

INTERNATIONAL SEARCH REPORT

International Application No

PCT/CA 03/00949

C.(Continuation) DOCUMENTS CONSIDERED TO BE RELEVANT

Category °	Citation of document, with indication, where appropriate, of the relevant passages	Relevant to claim No.
Y	US 5 947 323 A (FREEK MICHAEL ET AL) 7 September 1999 (1999-09-07) figure 1	20
A	-----	1
A	US 5 984 125 A (GENEROSE EDWARD ET AL) 16 November 1999 (1999-11-16) column 4, line 42-58 figure 4	1,3,5,6, 21
A	----- US 5 893 474 A (HERRMANN KLAUS-JUERGEN ET AL) 13 April 1999 (1999-04-13) column 3, line 58-62 column 4, line 48-64 figures 2,3,10 -----	7

INTERNATIONAL SEARCH REPORT

Information on patent family members

International Application No

PCT/CA 03/00949

Patent document cited in search report		Publication date	Patent family member(s)		Publication date
US 5540342	A	30-07-1996	NONE		
JP 10218209	A	18-08-1998	NONE		
US 5725115	A	10-03-1998	AT	173704 T	15-12-1998
			AU	701971 B2	11-02-1999
			AU	4479996 A	11-09-1996
			BR	9607515 A	30-12-1997
			CA	2210633 A1	29-08-1996
			WO	9626122 A1	29-08-1996
			CN	1175930 A	11-03-1998
			DE	59600869 D1	07-01-1999
			EP	0810952 A1	10-12-1997
			ES	2124625 T3	01-02-1999
			HU	9702245 A2	30-03-1998
			IL	116937 A	30-10-1998
			JP	11500091 T	06-01-1999
			NZ	300142 A	25-02-1999
			PL	321942 A1	05-01-1998
			TR	9700740 T1	21-02-1998
			ZA	9601311 A	06-09-1996
US 5947323	A	07-09-1999	CA	2212858 A1	27-02-1998
			CA	2415785 A1	27-02-1998
			US	6505753 B1	14-01-2003
US 5984125	A	16-11-1999	AU	744838 B2	07-03-2002
			AU	2330199 A	02-08-1999
			BR	9907089 A	24-10-2000
			CA	2318634 A1	22-07-1999
			CN	1288430 T	21-03-2001
			EP	1056652 A1	06-12-2000
			JP	2002509057 T	26-03-2002
			TR	200002125 T2	21-12-2000
			WO	9936326 A1	22-07-1999
			US	6158603 A	12-12-2000
US 5893474	A	13-04-1999	AT	179135 T	15-05-1999
			AU	687201 B2	19-02-1998
			AU	2520995 A	19-01-1996
			BR	9505499 A	12-08-1997
			WO	9600172 A1	04-01-1996
			CN	1129926 A ,B	28-08-1996
			DE	59505704 D1	27-05-1999
			EP	0714369 A1	05-06-1996
			ES	2132665 T3	16-08-1999
			HU	74662 A2	28-01-1997
			IL	114036 A	10-03-1998
			JP	9502412 T	11-03-1997
			NZ	285721 A	24-02-1997
			PL	313137 A1	10-06-1996
			RU	2141917 C1	27-11-1999
			US	6116451 A	12-09-2000
			ZA	9505205 A	14-02-1996