

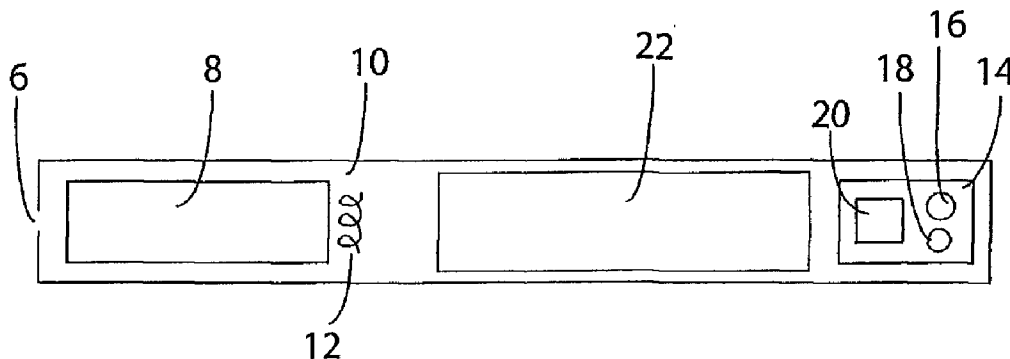

(22) Date de dépôt/Filing Date: 2013/10/09
 (41) Mise à la disp. pub./Open to Public Insp.: 2014/04/24
 (45) Date de délivrance/Issue Date: 2021/09/07
 (62) Demande originale/Original Application: 2 886 490
 (30) Priorité/Priority: 2012/10/19 (GB1218816.5)

(51) Cl.Int./Int.Cl. *A24F 40/57* (2020.01),
A24F 40/10 (2020.01), *G01D 21/02* (2006.01),
H05B 1/02 (2006.01)
 (72) Inventeur/Inventor:
 LORD, CHRISTOPHER, GB
 (73) Propriétaire/Owner:
 NICOVENTURES TRADING LIMITED, GB
 (74) Agent: SMART & BIGGAR IP AGENCY CO.

(54) Titre : DISPOSITIF DE FOURNITURE DE VAPEUR ELECTRONIQUE
 (54) Title: ELECTRONIC VAPOUR PROVISION DEVICE



(57) Abrégé/Abstract:

An electronic inhalation device comprising a power cell, a heating element and a computer. The computer comprises a computer processor, a memory and an input- output means. The device further comprises a temperature sensor. The computer is configured in use to obtain a temperature reading from the temperature sensor and adjust the heating temperature of the heating element based on the temperature reading.

ABSTRACT

5 An electronic inhalation device comprising a power cell, a heating element and a computer. The computer comprises a computer processor, a memory and an input-output means. The device further comprises a temperature sensor. The computer is configured in use to obtain a temperature reading from the temperature sensor and adjust the heating temperature of the heating element based on the temperature reading.

Electronic Vapour Provision Device

This application is divided from Canadian Patent Application Serial No. 2,886,490 filed on October 9, 2013.

5 Technical Field

The specification relates to electronic vapour provision devices. More particularly, but not exclusively, the present specification concerns electronic vapour provision devices such as electronic cigarettes.

Background

10 Electronic vapour provision devices are typically cigarette-sized and function by allowing a user to inhale a nicotine vapour from a liquid store by applying a suction force to a mouthpiece. Some electronic vapour provision devices have a pressure sensor that activates when a user applies the suction force and causes a heater coil to heat up and vaporise the liquid. Electronic vapour provision devices include electronic cigarettes.

15 Summary

There is described an electronic vapour provision device comprising a power cell, a heating element and a computer, where the computer comprises a computer processor, a memory and an input-output means; wherein the device further comprises a temperature sensor, wherein the computer is configured in use to obtain a temperature reading from the
20 temperature sensor and adjust the heating temperature of the heating element based on the temperature reading.

Having a temperature sensor has the advantage that the device can use temperature readings to provide a more sophisticated device, implementing operations for both control and safety.

Suitably, the electronic vapour provision device is an electronic cigarette.

25 Suitably, the computer is a microprocessor.

Suitably, the electronic vapour provision device comprises a first end and a second end, where the first end is a mouthpiece end, the second end is a tip end and the temperature sensor is located towards the tip end. Suitably, the computer is located towards the tip end. Suitably, the pressure sensor is located towards the tip end.

By locating the temperature sensor towards the tip end of the device ensures that the sensor is the furthest distance from the mouthpiece end. Typically a vaporiser comprising a heating element is located towards the mouthpiece end so it is advantageous to keep the temperature sensor far away. This ensures that the temperature sensor is not significantly affected by the heat from the heating element, and the temperature sensor can therefore measure ambient environmental temperature more reliably. Also, a liquid store is typically located near the mouthpiece end. So locating the temperature sensor, pressure sensor and computer towards the tip end minimizes the risk of liquid interfering with these components.

Suitably, the temperature sensor is configured in use to measure ambient temperature.
Suitably, pressure sensor is configured in use to measure ambient pressure. Suitably, the computer is configured in use to read both pressure and temperature at substantially the same time.

By measuring both the temperature and pressure at substantially the same time, the computer is therefore able to gain a snapshot of these values and allow for any required physical adjustments or compensations.

Suitably, the combined sensor is a calibrated sensor. Suitably, the calibrated sensor is calibrated for pressure and temperature. Suitably, the calibrated sensor is calibrated for use in atmospheric conditions.

A combined sensor ensures not only that the temperature and pressure are measured at the same time, but also at the same location. This gives a much more accurate determination of these values. A combined unit also has the advantage that only a single unit is needed leading to easier fabrication and a smaller component. Also, by using a sensor that is purposely designed to measure both temperature and pressure at the same time and location, a calibrated sensor can be used that is calibrated especially for this purpose and therefore provides a more accurate reading.

Suitably, the combined sensor is configured in use to determine the temperature and the pressure and provide a pressure reading that is dependent on the temperature.

Suitably, the combined sensor is configured in use to determine the temperature and the pressure and provide a substantially linear relationship between a voltage output and the measured pressure.

Suitably, the computer is configured in use to obtain a temperature reading from the temperature sensor and pressure reading from the pressure sensor and adjust the pressure reading to compensate for the temperature reading.

5 Since pressure and temperature are related and affect one another, the combined sensor can be used to compensate for changes to pressure for a given temperature. Advantageously, this can be achieved by the combined sensor itself or by the computer.

Suitably, the computer is configured in use to deliver an electrical current to the heating element when a pressure measured by the pressure sensor is reduced below a threshold pressure. Suitably, the computer is configured in use to obtain a temperature reading
10 from the temperature sensor and adjust the threshold pressure based on the temperature reading.

Given that the device is activated by a user sucking on the device and reducing the pressure past a threshold pressure, a correct pressure measurement is essential for accurate use. Thus, allowing for changes to this threshold pressure value allows for a
15 more accurate device.

Suitably, the electronic vapour provision device comprises a control unit and a vaporiser, where the control unit comprises the power cell, the computer, the pressure sensor and the temperature sensor, and the vaporiser comprises a heating element.

Suitably, the device further comprises a liquid store, configured in use to supply liquid
20 to the vaporiser heating element.

Suitably, the computer is configured in use such that the vaporiser vaporises a predetermined amount of liquid.

Suitably, the computer is configured in use such that the vaporiser vaporises a predetermined amount of liquid per unit time.

25 Suitably, the computer is configured in use such that the vaporiser vaporises substantially the same amount of liquid each time.

Suitably, the computer is configured in use such that the vaporiser vaporises substantially the same amount of liquid per unit time, each time.

Suitably, the computer is configured in use to obtain a temperature reading from the temperature sensor and adjust the vaporisation such that the vaporiser vaporises substantially the same amount of liquid per unit time, each time.

5 Suitably, the computer is configured in use to obtain a pressure reading from the pressure sensor and adjust the vaporisation such that the vaporiser vaporises substantially the same amount of liquid per unit time, each time.

Suitably, the computer is configured in use to obtain a temperature reading from the temperature sensor and adjust the heating temperature of the heating element based on the temperature reading.

10 Suitably, the computer is configured in use to obtain a pressure reading from the pressure sensor and adjust the heating temperature of the heating element based on the pressure reading.

Suitably, the computer is configured in use to obtain a temperature reading from the temperature sensor and adjust an electrical current delivered to the vaporiser based on
15 the temperature reading.

Suitably, the computer is configured in use to obtain a pressure reading from the pressure sensor and adjust an electrical current delivered to the vaporiser based on the pressure reading.

Suitably, the computer is configured in use to reduce the heating power delivered to the
20 heating element as the ambient temperature increases.

The heat output of the heating element is dependent on the starting temperature and the heating power. The vaporisation effect also depends on the starting temperature since this affects the viscosity of the liquid being vaporised. By measuring the starting temperature, the heating power can be controlled to provide a consistent heating and
25 vaporisation effect.

Suitably, the computer is configured in use to enter a wait mode when the temperature reading exceeds a first threshold temperature. Suitably, the wait mode is a lower power mode compared to a normal operating mode.

Suitably, in wait mode a vaporiser cannot be activated.

Suitably, the computer is configured to remain in wait mode for a predetermined wait time.

Having a wait mode when the temperature gets too hot provides added safety for the user and ensures that the user cannot be harmed.

5 Suitably, prior to leaving wait mode, the computer is configured in use to measure temperature and then remain in wait mode if temperature is above a second threshold temperature, or leave wait mode if temperature is below a second threshold temperature. Suitably, the first threshold temperature is equal to second threshold temperature.

10 Suitably, the computer is configured in use to disable the device if temperature measured by the temperature sensor is above a critical threshold temperature. Suitably, the device further comprises a fuse connected to the computer and the device is disabled by blowing the fuse.

If the device has exceeded a safe operating temperature where damage to the device could have occurred then it is advantageous to disable to device.

Brief Description of the Drawings

15 For a better understanding of the disclosure, and to show how example embodiments may be carried into effect, reference will now be made to the accompanying drawings in which:

Figure 1 is a side perspective view of an electronic vapour provision device;

Figure 2 is a side sectional view through the device of Figure 1;

20 Figure 3 is an exploded side perspective view of an electronic vapour provision device having separated mouthpiece and control unit;

Figure 4 is a side sectional view through the device of Figure 3 with connected mouthpiece and control unit;

Figure 5 is an exploded side perspective view of an electronic vapour provision device having separated mouthpiece, vaporiser and control unit;

25

Figure 6 is a side sectional view through the device of Figure 5 with connected mouthpiece, vaporiser and control unit;

Figure 7 is an exploded longitudinal sectional view of another embodiment of an electronic vapour provision device similar to that of Figures 3 and 4, and that of Figures 5 and 6, showing the internal components thereof in greater detail;

Figure 8 is a sectional view of the electronic vapour provision device of Figure 7 when assembled; and

Figure 9 is a schematic circuit diagram of the vapour provision device of Figures 7 and 8.

10 **Detailed Description**

Referring to Figure 1 and Figure 2 there is shown an electronic vapour provision device in the form of a cigarette-shaped electronic cigarette. The electronic vapour provision device has a mouthpiece 2 and a cigarette body 4. The mouthpiece 2 has an air outlet 6 at a first end and is connected to the cigarette body 4 at a second end.

15 Inside the electronic vapour provision device there is a liquid store 8 towards the mouthpiece end and a vaporiser 10 having a heating coil 12. The vaporiser 10 is arranged next to the liquid store 8 to allow liquid to be transferred onto the vaporiser 10 for vaporising. A circuit board 14 contains a pressure sensor 16, a temperature sensor 18 and a computer 20. A power cell 22 provides power to the device.

20 The general operation of the electronic vapour provision device is similar to that of known devices. When a user takes a draw on the electronic vapour provision device, a suction force is applied to the mouthpiece 2 and the air outlet 6. A reduced pressure inside the electronic vapour provision device causes the power cell 22 to provide power to the vaporiser 10 which in turn vaporises the nicotine liquid solution. The resultant
25 vapour is then inhaled by the user.

In this example the operation of the electronic vapour provision device goes beyond that of a general device. In use, when a user applies a suction force to the electronic vapour provision device, the resultant airflow causes a drop in pressure from ambient pressure to a lower pressure, within the device. The pressure sensor 16 provides a signal
30 to the computer 20. The computer 20 runs software that monitors the pressure signal from the pressure sensor 16 and when it determines that the pressure has been reduced

below a threshold pressure, the computer 20 provides an electrical current to the heating coil 12 in order to heat the heating coil 12 and vaporise liquid from the liquid store 8.

5 The temperature sensor 18 is adjacent the pressure sensor 16 and also provides a temperature signal to the computer 20. The circuit board 14 containing the pressure sensor 16, temperature sensor 18 and computer 20, is located towards the tip of the device. As such, the temperature sensor 18 is located at the furthest possible point from the vaporiser 10 and heating coil 12. This ensures that the temperature sensor 18 acts to measure the ambient temperature and is not affected by the heating coil 12 as it gets
10 hot in use.

The computer 20 receives a signal from the pressure sensor 16 and temperature sensor 18 and is able to determine both the ambient pressure and the ambient temperature at the same time. As such, since a measured pressure is dependent on the temperature at which it is measured, the computer 20 is able to adjust the pressure measurement for
15 the given temperature. In use, the computer is then able to use this adjusted pressure and determine when the adjusted reduced pressure caused by user inhalation passes a threshold pressure value.

Alternatively, the computer 20 can obtain a value for the ambient pressure and ambient temperature and adjust the threshold pressure value to give a compensated threshold
20 pressure. In use, the heating coil 12 is activated when the measured pressure is reduced past the compensated threshold pressure.

The computer 20 is also able to use the temperature reading for other purposes. The ambient temperature affects the vaporisation of liquid in two ways. Firstly, the viscosity of the liquid is temperature dependent and therefore the rate at which the liquid flows
25 onto the heating coil 12 and the rate at which vaporisation occurs is somewhat dependent on the ambient temperature. Secondly, the temperature the heating coil reaches is dependent on the electrical current or power applied to the coil and also the starting temperature of the coil and the rate at which liquid is transferred to the coil, since vaporisation itself removes heat from the coil. The computer 20 is therefore able
30 to measure the ambient temperature and adjust the current and heating power delivered to the coil to compensate for changes in ambient pressure. This therefore provides consistent vaporisation regardless of changes in the ambient temperature.

In addition, the computer 20 monitors the ambient temperature reading from the temperature sensor 18 to determine whether the device is safe for a user to operate. If the ambient temperature gets above a first safe threshold temperature then the device can enter a wait mode where the vaporiser is disabled. The device periodically measures
5 the temperature to determine when the ambient temperature is once again safe and fallen below a second safe threshold temperature. The first and second safe threshold temperature can be the same temperature, the first can be higher than the second or the second can be higher than the first.

The temperature sensor 18 can also be used to determine when the ambient
10 temperature exceeds a critical safe temperature. This is a temperature that can potentially cause damage to the device rendering it permanently unsafe to use. In this case the device permanently disables the device by blowing a fuse on the circuit board
14.

15 Figure 3 and Figure 4 show an electronic vapour provision device similar to that shown in relation to Figure 1 and Figure 2. The difference is that the mouthpiece 2 is releasably-attachable to the cigarette body 4. The mouthpiece comprises a female screw thread connection means, the device body 4 is a control unit 24 having a male screw thread connection means. The mouthpiece 2 and the control unit 24 can be screwed
20 together or taken apart.

In this example, the mouthpiece 2 comprises the liquid store 8 and the vaporiser 10 with heating coil 12. The control unit 24 comprises the power cell 22 and circuit board 14 with pressure sensor 16, temperature sensor 18 and computer 20. The screw thread connection provides an electrical connection such that when the mouthpiece 2 and
25 control unit 24 are screwed together, electrical current can be delivered to the heating coil 12 upon activation of the vaporiser 10.

Figure 5 and Figure 6 show an electronic vapour provision device similar to that shown in relation to Figure 3 and Figure 4. However in this example, the vaporiser 10 is removable from the mouthpiece 2. The mouthpiece 2 has a cylindrical opening that
30 forms an interference push-fit with the vaporiser 10. As such the mouthpiece 2 can be separated from the vaporiser 10. The mouthpiece 2 comprises the liquid store 8. The vaporiser 10 comprises the heating coil 12 and a wick 26. The wick 26 protrudes from

the end of the vaporiser 10 such that when the mouthpiece 2 and the vaporiser 10 are connected, the wick 26 dips into the liquid store 8.

In use, as a user inhales on the device, liquid is transferred from the liquid store 8 and onto the wick 26 before being transferred onto the heating coil 12 for vaporisation.

5 The device in this example also differs from previous examples in that the temperature sensor and pressure sensor form a combined sensor 28. Thus the combined sensor 28 is a single electronic component and is connected to the computer. The combined sensor 28 is able to provide simultaneous readings of both temperature and pressure to the computer 20. The combined sensor 28 is a calibrated sensor in that it has been
10 calibrated to provide accurate pressure and temperature signals dependent on one another. As such the sensor itself is able to provide an adjusted pressure reading that compensates for temperature variations.

The pressure sensor 16 and/or the combined pressure and temperature sensor 28, is suitably sufficiently sensitive to be able to operate according to the required parameters
15 described above. In this regard, the sensor may have a sensitivity of around +/- 5 Pa, and may have a sensitivity of +/- 3 Pa, and more suitably may have a sensitivity of +/- 1 Pa. Given that standard atmospheric pressure is in the order of around 100,000 Pa, it is clear that the sensor 16/28 is highly sensitive. The degree of sensitivity may be provided by the hardware used in the sensor itself, and also the compensatory
20 algorithm provided by the sensor which is loaded onto the computer 20. In use, the sensor provides raw pressure data, and raw temperature data may be provided either by the separate temperature sensor 18 or by the combined pressure and temperature sensor 28. This is fed to the computer 20 which calculates the pressure compensated for the temperature. However, in an alternative embodiment, the sensors 16, 18, 28
25 may comprise an internal microprocessor such that the sensors 16, 18, 28 themselves may be able to provide the compensated reading as a direct output. The temperature and pressure sensor 18, 16, or combined temperature and pressure sensor 28, are also present as a combination, i.e. on one circuit board 14. This is advantageous within an electronic vapour provision device because the temperature profile may vary across
30 such devices for a number of reasons – for example, the heater being on, holding of the device etc. The output from the sensor(s) 16, 18, 28 is also digital, which is advantageous in the context of the device as a whole.

Within the devices described above, temperature can be independently monitored at the same time as providing compensatory data for the pressure reading. This is because the sensor(s) provide raw temperature and pressure outputs. This enables the sensor(s) to also act as a safety component in that it/they can provide information to the computer about the temperature of the device which can then signal a cut-out at certain pre-determined temperatures, for example 50 degrees Celcius.

The compensated pressure reading is also important. For regulatory purposes, it is advantageous that the device does not operate inadvertently – such as when the device is not in the mouth, or even when the device is in the mouth of a user but they are not intentionally inhaling. One way of achieving this is by setting defined pressure thresholds and ensuring that they are not “breached” as a result of a faulty sensor.

Figures 7 and 8 illustrate another embodiment of an electronic vapour provision device in the form of an electronic cigarette. The device is similar to the embodiment shown in Figures 3 and 4, and the embodiment shown in Figures 5 and 6, although the embodiment in Figures 7 and 8 shows the internal components thereof in greater detail. The device comprises a mouthpiece 31, vapouriser device 32 and control unit 33 which can be assembled as shown in Figure 8 to provide a generally cylindrical device that can be used as a substitute for a conventional tobacco burning cigarette. The control unit 33 is provided with a threaded extension 34 that is received in an interior thread 35 in the vapour device 32. The mouthpiece 31 comprises a generally cylindrical plastics casing 36 that can be push-fitted on to the vapour device 32.

The mouthpiece 31 has an outlet 37 to supply vapour to the mouth of the user and an outlet passageway 38 for the vapour which, in use is produced by the vapour device 32. The mouthpiece 31 also includes a liquid reservoir comprising a porous storage matrix 39 such as plastics open foam material impregnated with a vaporisable liquid, such as a nicotine containing liquid that in use is vaporised by the vapour device 32. The matrix 39 acts as a reservoir for the liquid and since the mouthpiece 31 is readily removable and replaceable, it can be used as a refill capsule when the liquid in the porous matrix 39 becomes depleted and needs to be replenished.

The vapour device 32 includes an electronic heating coil 40 that is wound around a ceramic core 41, supported on a ceramic base 42. A generally U-shaped wicking member 43 is configured to wick liquid from the reservoir 39 towards the heating

element 40 by capillary action. The wicking member 43 may for example be made of a metallic foam such as nickel foam.

The heater coil 40 is powered by a rechargeable battery 44 located in the control unit 33 through electrical contacts 48, 49 (not shown in Figs 7 and 8, see Figure 9) which
5 electrically couple the heater coil to the battery 44 when the control unit 33 is fitted to the vapour device 32 by the engagement of threads 34, 35. The electrical power of the battery 44 is supplied to the heater coil 40 under the control of a control circuit 45 mounted on circuit board 46 within the control unit 33.

As shown in Figure 9, the control circuit 45 includes a micro controller 47 powered by
10 battery 44 to supply an electric heating current to the coil 40 through the contacts 48, 49 that are brought into electrical connection when the control unit 33 is threadedly engaged with the vapour device 32 by means of threads 34, 35 shown in Figure 7.

A pressure sensor 50 detects when a user draws on the mouthpiece 38, as described in more detail hereinafter.

15 Also, a signalling unit 51 is provided to provide audio or visual outputs to the user indicative of operational conditions of the device. For example, the signalling device may include a light emitting diode that glows red when the user draws on the device. The signalling device may provide predetermined audio or visual signals to indicate for example that the battery 44 needs to be recharged.

20 The supply of current from the battery 44 to the mouth controller is controlled by switching transistor 52.

When the user draws on the mouthpiece 1 so as to draw vapour through the outlet 37, the pressure sensor 50 detects the drop in pressure which is communicated from within the vapour device 32 through the interior of the control unit 33 to the circuit board 45.
25 Microcontroller 47 responds to the pressure drop detected by the sensor 50 to supply electrical current to the heater coil 40, which vaporises liquid supplied by capillary action through the U-shaped wicking member 43. An air inlet passageway 55 is provided in the joint between the vapour unit 32 and control unit 33 so that air can be drawn through the threaded extension 34 of the control unit 33 into the vapour device
30 32 in the direction of arrows A, so that the resulting vapour is drawn in the direction of arrows B through passageway 38 to the outlet 37.

The operation of the device of Figures 7 and 8 may be the same as that of the devices of Figures 1 to 6 described previously and so a detailed description of such operation will not be repeated here. However, it is intended that the control circuit 46 of the embodiment of Figures 7 and 8 may be configured as per the circuit board 14 of the embodiments of Figures 1
5 to 6, and vice versa. Specifically, the circuit board 46 may comprise a temperature sensor 18, or a combined temperature and pressure sensor 28. Also, the pressure sensor 50 may be disposed on the circuit board 46 within the control unit 33 and the vapour device 32 may be in fluid communication with the area within the control unit 33, via an open passageway for example (not shown), such that a drop in pressure within the vapour device 32 is detectable
10 by a pressure sensor on the circuit board 46 within control unit 33. Also, the microcontroller 47 of the embodiment of Figures 7 and 8 may be programmed as per the computer 20 of the embodiment of Figures 1 to 6 to monitor both measured temperature and pressure from the sensor(s) to control the device accordingly and as described previously.

Although examples have been shown and described it will be appreciated by those skilled in
15 the art that various changes and modifications might be made without departing from the scope of the invention. The computer processor could be a microprocessor or a microcontroller. The device is not restricted to being cigarette shaped. The computer processor, temperature sensor and pressure sensor are not restricted to being on the same circuit board. The heating coil used for vaporisation could be replaced by another type of
20 non-coil heating element.

In order to address various issues and advance the art, the entirety of this disclosure shows by way of illustration various embodiments in which the claimed invention(s) may be practiced and provide for superior electronic vapour provision devices. The advantages and features of the disclosure are of a representative sample of embodiments only, and are not
25 exhaustive and/or exclusive. They are presented only to assist in understanding and teach the claimed features. It is to be understood that advantages, embodiments, examples, functions, features, structures, and/or other aspects of the disclosure are not to be considered limitations on the disclosure as defined by the claims or limitations on equivalents to the claims, and that other embodiments may be utilised and modifications may be made without
30 departing from the scope of the disclosure. Various embodiments may suitably comprise, consist of, or consist essentially of, various combinations of the disclosed elements, components, features, parts, steps, means, etc. In addition, the disclosure includes

other inventions not presently claimed, but which may be claimed in future. Any feature of any embodiment can be used independently of, or in combination with, any other feature.

THE EMBODIMENTS OF THE INVENTION IN WHICH AN EXCLUSIVE PROPERTY OR PRIVILEGE IS CLAIMED ARE DEFINED AS FOLLOWS:

1. An electronic vapour provision device comprising a power cell, a heating element and a computer, where the computer comprises a computer processor, a memory and an input-output means; wherein the device further comprises a temperature sensor, wherein the computer is configured in use to obtain a temperature reading from the temperature sensor and adjust the heating temperature of the heating element based on the temperature reading.
2. The electronic vapour provision device of claim 1, wherein the electronic vapour provision device is an electronic cigarette.
3. The electronic vapour provision device of claim 1 or claim 2, wherein the computer is a microprocessor.
4. The electronic vapour provision device of any one of claims 1 to 3, wherein the electronic vapour provision device comprises a first end and a second end, where the first end is a mouthpiece end, the second end is a tip end and the temperature sensor is located towards the tip end.
5. The electronic vapour provision device of claim 4, wherein the computer is located towards the tip end.
6. The electronic vapour provision device of any one of claims 1 to 5, wherein the temperature sensor is configured in use to measure ambient temperature.
7. The electronic vapour provision device of any one of claims 1 to 3 further comprising a pressure sensor.
8. The electronic vapour provision device of claim 7, wherein the electronic vapour provision device comprises a first end and a second end, where the first end is a

mouthpiece end, the second end is a tip end and the pressure sensor is located towards the tip end.

9. The electronic vapour provision device of claim 7 or claim 8, wherein the pressure sensor is configured in use to measure ambient pressure.

10. The electronic vapour provision device of any one of claims 7 to 9, wherein the computer is configured in use to read both pressure and temperature at substantially the same time.

11. The electronic vapour provision device of any one of claims 7 to 10, wherein the pressure sensor and temperature sensor form a combined sensor.

12. The electronic vapour provision device of claim 11, wherein the combined sensor is a calibrated sensor.

13. The electronic vapour provision device of claim 12, wherein the calibrated sensor is calibrated for pressure and temperature.

14. The electronic vapour provision device of claim 12 or claim 13, wherein the calibrated sensor is calibrated for use in atmospheric conditions.

15. The electronic vapour provision device of any one of claims 11 to 14, wherein the combined sensor is constructed as a single electronic component.

16. The electronic vapour provision device of any one of claims 11 to 15, wherein the combined sensor is configured in use to determine the temperature and the pressure and provide a pressure reading that is dependent on the temperature.

17. The electronic vapour provision device of any one of claims 11 to 16, wherein the combined sensor is configured in use to determine the temperature and the pressure and provide a substantially linear relationship between a voltage output and the measured pressure.

18. The electronic vapour provision device of any one of claims 7 to 17, wherein the computer is configured in use to deliver an electrical current to the heating element when a pressure measured by the pressure sensor is reduced below a threshold pressure.
19. The electronic vapour provision device of claim 18, wherein the computer is configured in use to obtain the temperature reading from the temperature sensor and adjust the threshold pressure based on the temperature reading.
20. The electronic vapour provision device of any one of claims 7 to 19, wherein the electronic vapour provision device comprises a control unit and a vaporiser, where the control unit comprises the power cell, the computer, the pressure sensor and the temperature sensor, and the vaporiser comprises the heating element.
21. The electronic vapour provision device of claim 20, wherein the device further comprises a liquid store, configured in use to supply liquid to the vaporiser heating element.
22. The electronic vapour provision device of claim 21, wherein the computer is configured in use such that the vaporiser vaporises a predetermined amount of liquid.
23. The electronic vapour provision device of claim 21 or claim 22, wherein the computer is configured in use such that the vaporiser vaporises a predetermined amount of liquid per unit time.
24. The electronic vapour provision device of any one of claims 21 to 23, wherein the computer is configured in use such that the vaporiser vaporises substantially the same amount of liquid each time.
25. The electronic vapour provision device of any one of claims 21 to 24, wherein the computer is configured in use such that the vaporiser vaporises substantially the same amount of liquid per unit time, each time.

26. The electronic vapour provision device of any one of claims 21 to 25, wherein the computer is configured in use to obtain a temperature reading from the temperature sensor and adjust the vaporisation such that the vaporiser vaporises substantially the same amount of liquid per unit time, each time.

27. The electronic vapour provision device of any one of claims 20 to 26, wherein the computer is configured in use to obtain a temperature reading from the temperature sensor and adjust an electrical current delivered to the vaporiser based on the temperature reading.

28. The electronic vapour provision device of any one of claims 20 to 27, wherein the computer is configured in use to reduce the heating power delivered to the heating element as the ambient temperature increases.

29. The electronic vapour provision device of any one of claims 21 to 28, wherein the computer is configured in use to obtain the pressure reading from the pressure sensor and adjust the vaporisation such that the vaporiser vaporises substantially the same amount of liquid per unit time, each time.

30. The electronic vapour provision device of any one of claims 20 to 29, wherein the computer is configured in use to obtain a pressure reading from the pressure sensor and adjust the heating temperature of the heating element based on the pressure reading.

31. The electronic vapour provision device of any one of claims 20 to 30, wherein the computer is configured in use to obtain a pressure reading from the pressure sensor and adjust an electrical current delivered to the vaporiser based on the pressure reading.

32. The electronic vapour provision device of any one of claims 1 to 31, wherein the computer is configured in use to enter a wait mode when the temperature reading exceeds a first threshold temperature.

33. The electronic vapour provision device of claim 32, wherein the wait mode is a lower power mode compared to a normal operating mode.

34. The electronic vapour provision device of claim 32 or claim 33, wherein in the wait mode a vaporiser cannot be activated.
35. The electronic vapour provision device of any one of claims 32 to 34, wherein the computer is configured to remain in the wait mode for a predetermined wait time.
36. The electronic vapour provision device of any one of claims 32 to 35, wherein prior to leaving the wait mode, the computer is configured in use to measure temperature and then remain in the wait mode if temperature is above a second threshold temperature, or leave the wait mode if temperature is below a second threshold temperature.
37. The electronic vapour provision device of claim 36, wherein the first threshold temperature is equal to second threshold temperature.
38. The electronic vapour provision device of any one of claims 1 to 37, wherein the computer is configured in use to disable the device if the temperature reading measured by the temperature sensor is above a critical threshold temperature.
39. The electronic vapour provision device of claim 38, wherein the device further comprises a fuse connected to the computer and the device is disabled by blowing the fuse.

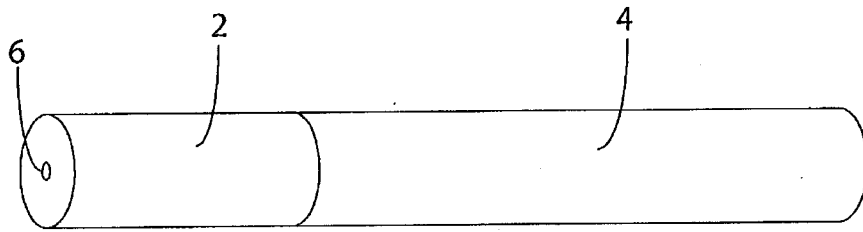

FIG. 1

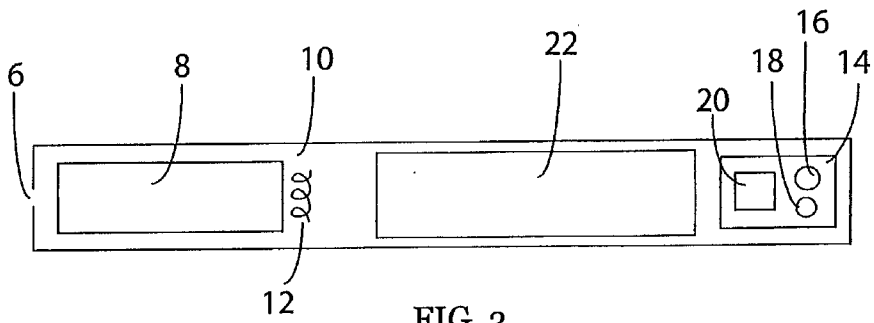

FIG. 2

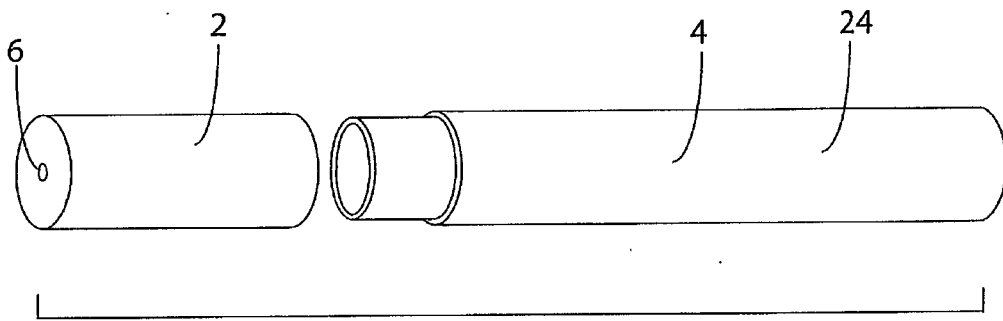

FIG. 3

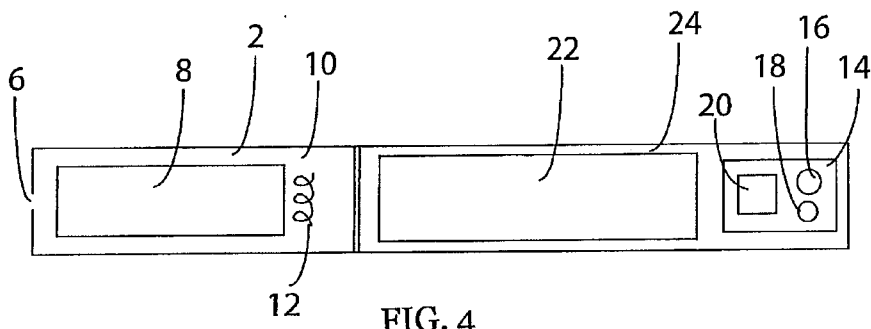

FIG. 4

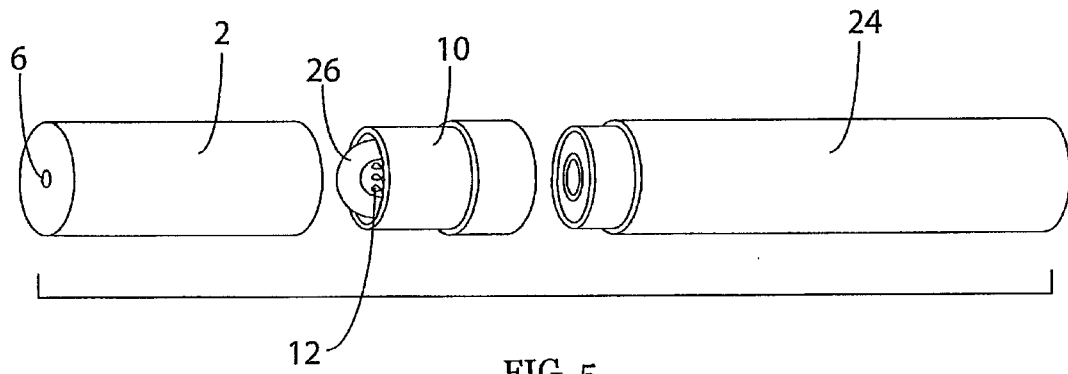

FIG. 5

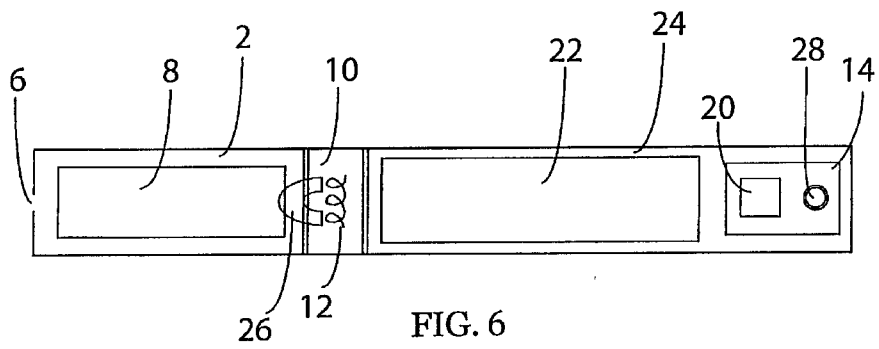

FIG. 6

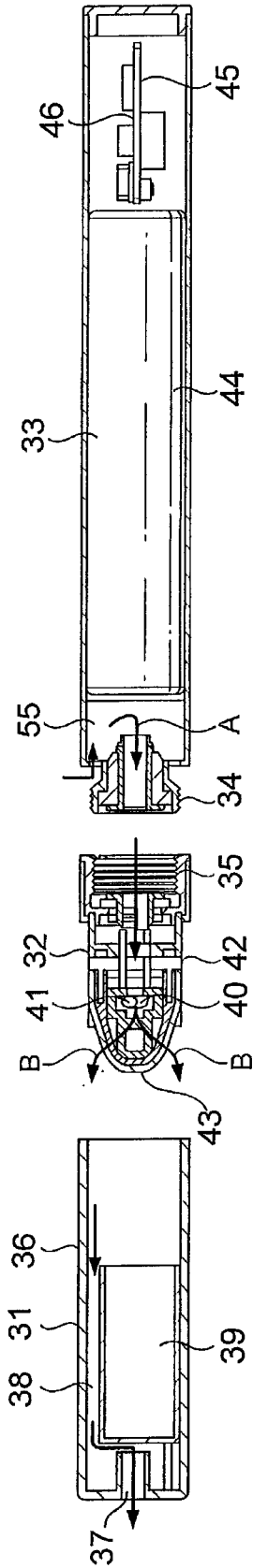

FIG. 7

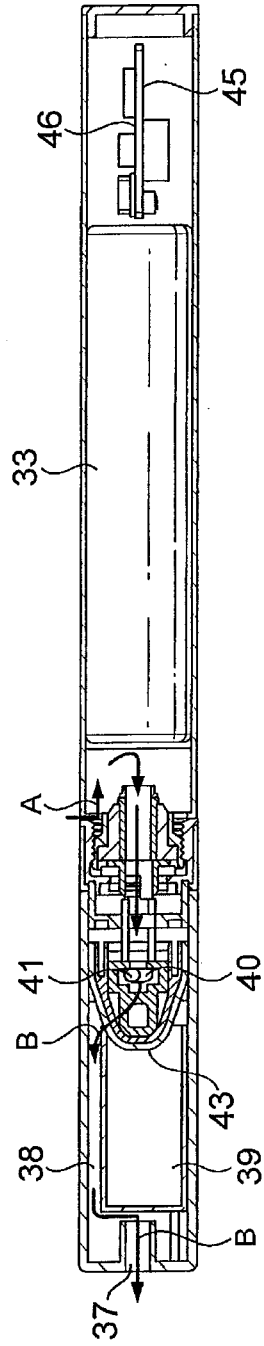

FIG. 8

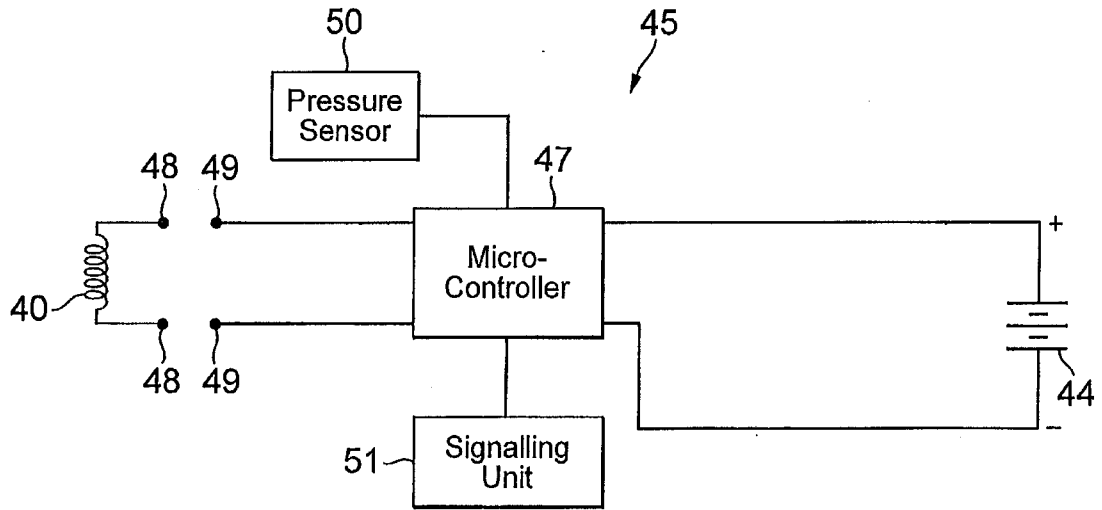

FIG. 9

