

(19)
(12)

(KR)
(A)

(51) 。 Int. Cl. ⁷
H04B 1/38

(11)
(43)

2001 - 0077355
2001 08 17

(21) 10 - 2000 - 0005103
(22) 2000 02 02

(71)

575

(72)

가 818

(74)

:

(54)

: 가 2 .

: 1 2 , 1 2 1 2 .

: 가 가 .

1

(heat seal), (EL),

1

2

3

4a 4b

5

* *

1: 2:

20: PCB30,40:

50: (heat seal)60:

100: 1 110: 1

200: 2 210: 2

가 (heat seal) 가 가 가

LCD(liquid crystal display), TFT(thin film transistor) - LCD, FED(Field emission display), PDP(plasma display panel) EL(electro luminescent)

가

, PDA

가

() 가

가

가

가

가

4

4a 4b (1) 1 (1) (100) 2 (2)가 (200)가 (12)

1 (100) (1) (2) 1

2 (200) 1 (100)

5 (LCD)

1 2 가 PCB(20) 2 (3)(4)가 (114)(116)

(3) 1 (100) 2 (112)(118) 2 (200) (110)(210)

(210)가 (110)가 (100)(200) (3)(4)

(3)(4)가 2

e: (110)(210) LED(Light Emitting Diode), EL(Electro Luminescenc

가 2μm

1 2 가 가

LED 가 가

가 2

가

1 2 1 2 1 2

2 ㅈ

1

(50) 1 (100) 2 (200) 2 (30)(40) (60)가 (30)(40)

(50: Heat Seal) (Base film) (Polyester) (Hot melt) 가

(ITO 가 (PCB ((tool)

(Pitch)가

0.25mm

2 (30)(40)

(30) 2

ITO PET(31) 가 (33) (33)

31) (33) (35) (35) (35) (37) (39) (37) (

(30)가

3

(30)(40) 1 PCB(20) (50) 가 (30)(40)가 PCB(20) (112), (114), (116), (118) (30) 1 (110)가 1 (110)

PCB(20) 214)(216) 2 (40) 가 2 (212)(218) 2 ((210)가

가

가 , 가

가 2 가 .

(57)

1. 가 , 1 2 가 , 1 2 , 1 2 가 .

2. 1 , 2 가 .

1 , (heat seal) .

1

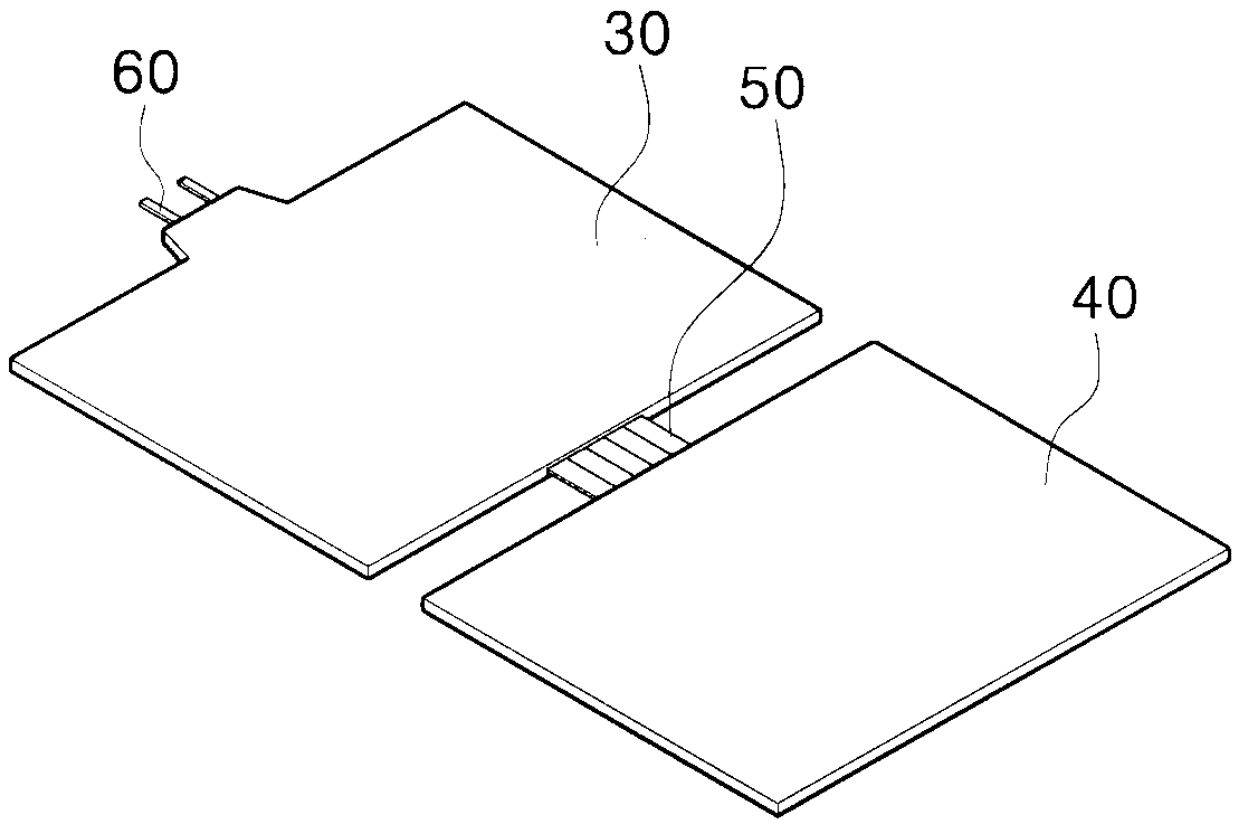

2

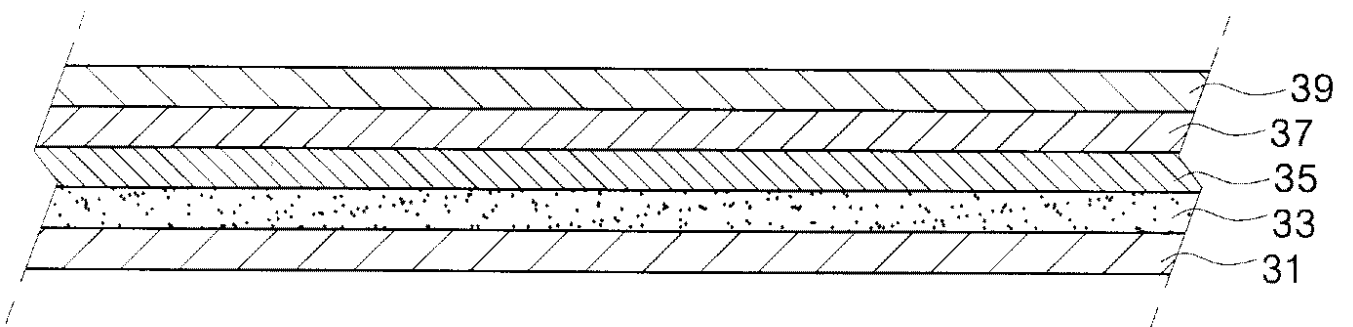

3

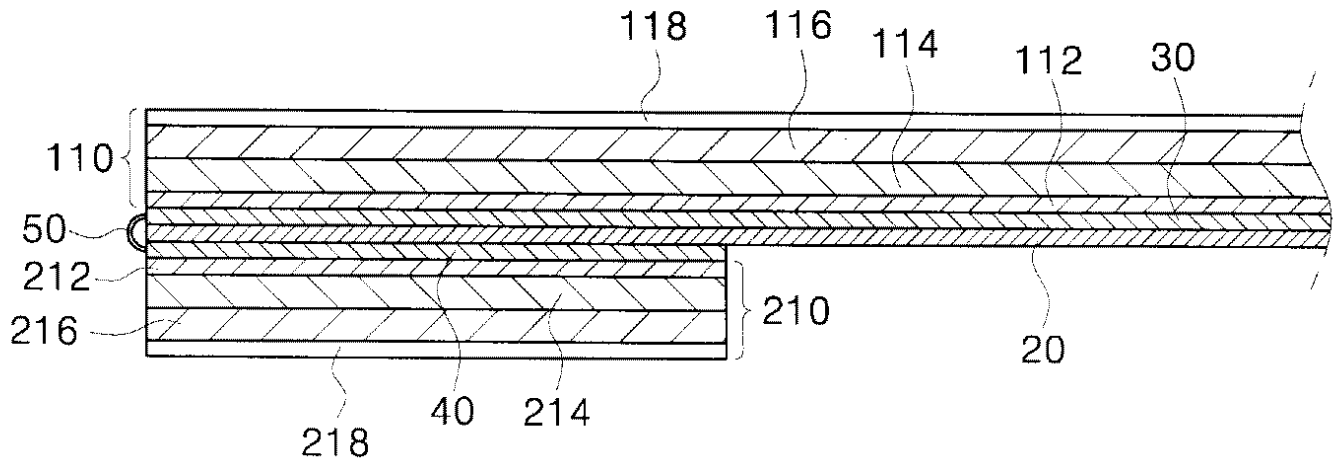

4a

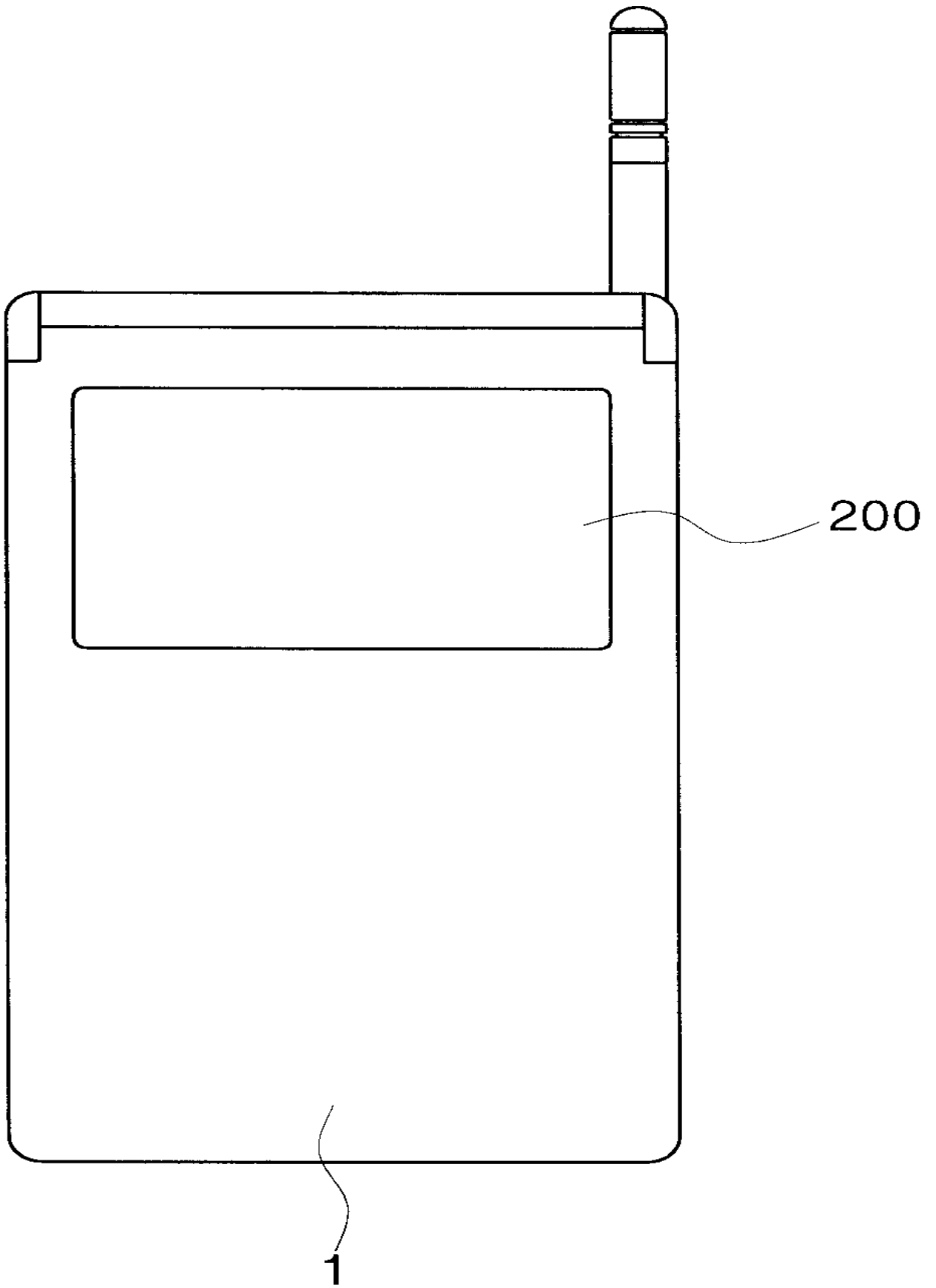

4b

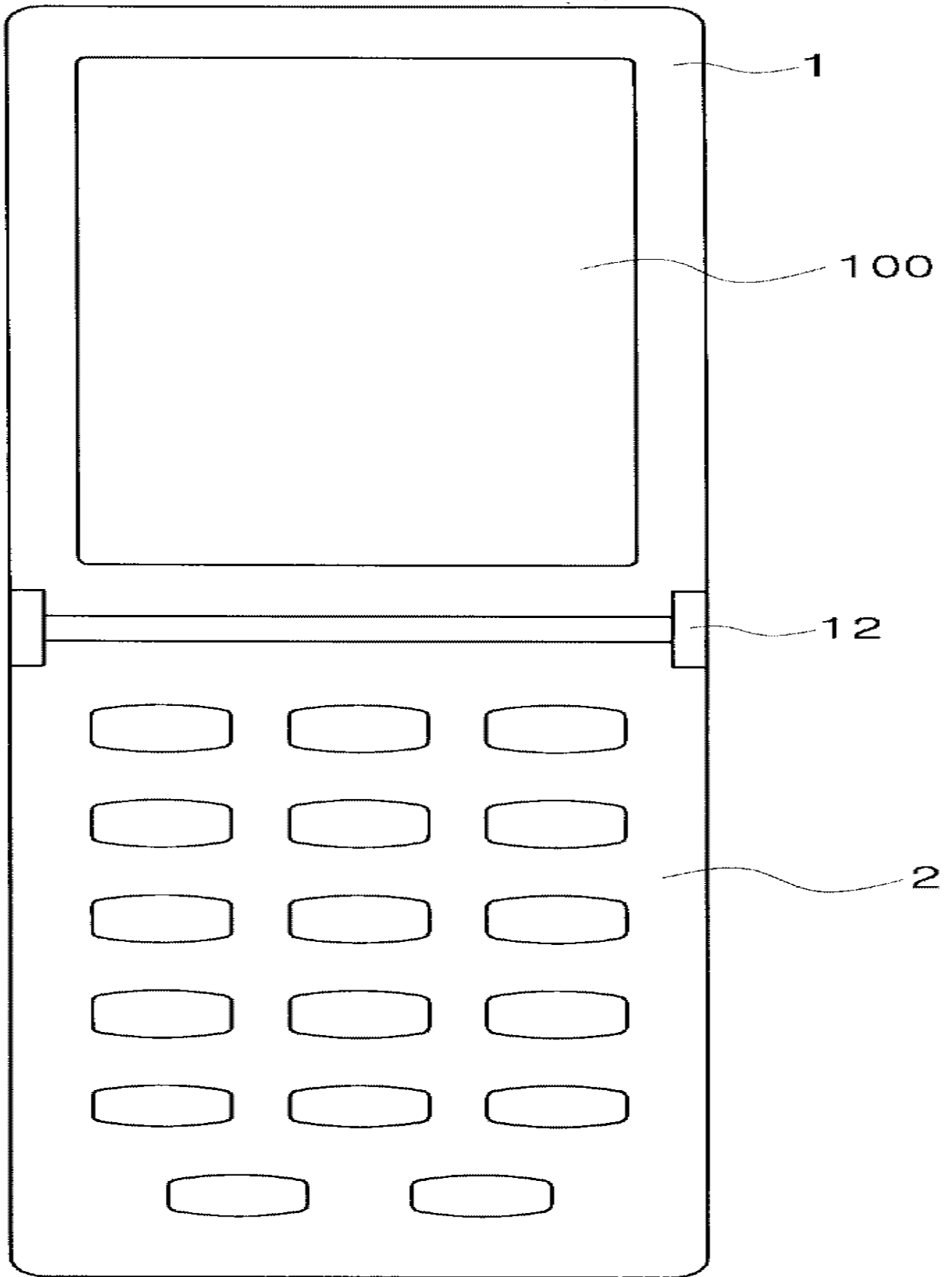

5

